

Housing - HC-ADV-B06-HHWH-1SGM20-PL - 1404224

Technical data

Dimensions

Width of the assembly cutout	35 mm
------------------------------	-------

Ambient conditions

Degree of protection of housing (IP)	IP66
	IP67
Ambient temperature (operation)	-40 °C ... 100 °C

General

Note	for contact inserts HC-B06, BB10, DD24, M
Size	B6
Housing type	Sleeve housing
Color	black
Locking type	with screw locking
Torque	3 Nm (Locking screw)
Fixing screws	M6 (screw head: 5 mm Allen screw)
No. of cable outlets	1
Cable outlet	lateral
Screw connection	with
Type of the screw connection	1x M20
Housing material	PA
Seal material	NBR
Cable seal material	NBR
Material lock	Stainless steel
Material of locking screw	Stainless steel
Flammability rating according to UL 94	V0 (Housing)
Assembly instructions	M6 locking screw, with 5 mm Allen screw head

Environmental Product Compliance

China RoHS	Environmentally friendly use period: unlimited = EFUP-e
	No hazardous substances above threshold values

Drawings

Housing - HC-ADV-B06-HHWH-1SGM20-PL - 1404224

Dimensional drawing

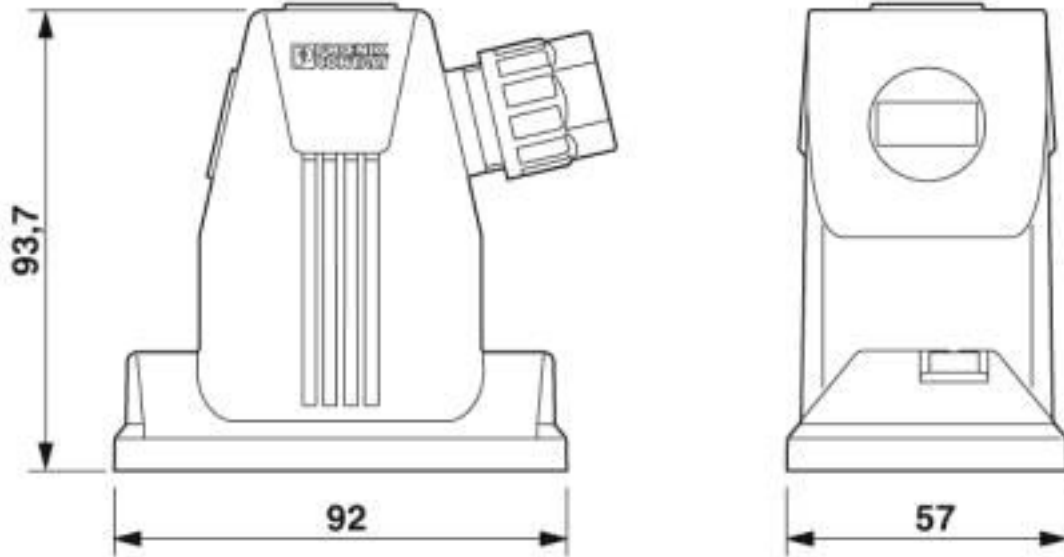

Dimensional drawing

Dimensional drawing

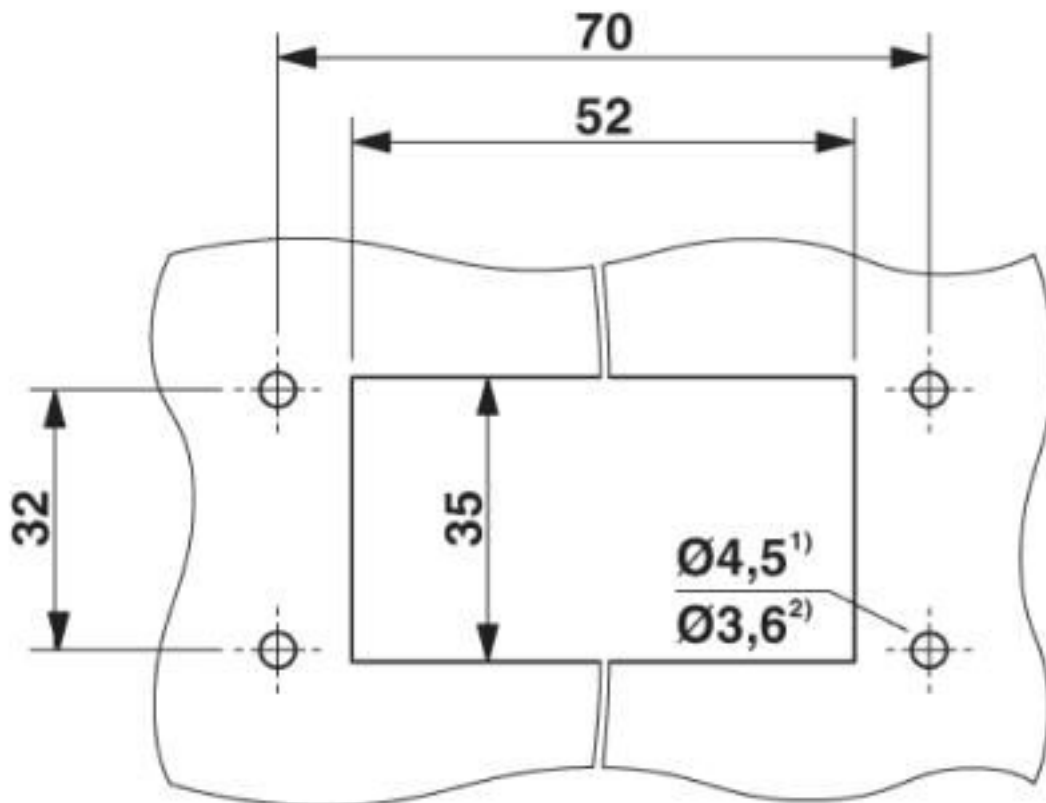

Mounting cutout

Housing - HC-ADV-B06-HHWH-1SGM20-PL - 1404224

- 1) when M4 screws are used
- 2) when self-tapping Torx® screws are used (Torx® 20, M4)

Classifications

eCl@ss

eCl@ss 10.0.1	27440202
eCl@ss 4.0	27140800
eCl@ss 4.1	27140800
eCl@ss 5.0	27143400
eCl@ss 5.1	27261200
eCl@ss 6.0	27261200
eCl@ss 7.0	27440202
eCl@ss 8.0	27440202
eCl@ss 9.0	27440202

ETIM

ETIM 3.0	EC000516
ETIM 4.0	EC000437
ETIM 5.0	EC000437
ETIM 6.0	EC000437
ETIM 7.0	EC000437

UNSPSC

UNSPSC 6.01	31261502
UNSPSC 7.0901	31261502
UNSPSC 11	31261502
UNSPSC 12.01	31261502
UNSPSC 13.2	31261501
UNSPSC 18.0	31261501
UNSPSC 19.0	31261501
UNSPSC 20.0	31261501
UNSPSC 21.0	31261501

Approvals

Approvals

Approvals

EAC / DNV GL

Ex Approvals

Approval details

Housing - HC-ADV-B06-HHWH-1SGM20-PL - 1404224

Approvals

EAC		RU C- DE.AI30.B.01102
-----	--	--------------------------

DNV GL		https://approvalfinder.dnvgl.com/	TAE000037S
--------	--	---	------------

Accessories

Accessories

Device marking

Snap-in markers - US-EMP (20X9) - 0829439



Snap-in markers, Card, white, unlabeled, can be labeled with: BLUEMARK ID COLOR, BLUEMARK ID, THERMOMARK PRIME, THERMOMARK CARD 2.0, THERMOMARK CARD, mounting type: snapped into marker carrier, lettering field size: 20 x 9 mm, Number of individual labels: 70

Panel mounting flange

Mounting flange - HC-B-AF - 1686533



Panel mounting flange for HEAVYCON-ADVANCE TMS housing with screw locking

Mounting flange - HC-B-AF-SET - 1604638



Panel mounting flange for screw locking, set comprising 2 panel mounting flanges with 4 self-tapping screws (M4, Torx®) and 4 fan-type washers

Screwdriver tools

Housing - HC-ADV-B06-HHWH-1SGM20-PL - 1404224

Accessories

Screwdriver - SF-M BH - 1212070



Bit screwdriver, with 1/4" quick-action chuck, handle length 119 mm, 2-component handle, with non-slip grip, suitable for bits according to DIN 3126-C 6.3 and E 6.3/ISO 1173, magnetic

Screwdriver - SF-BIT-HEXB 5-89 - 1208911



Screw bit, hexagonal with ball head, E6.3-1/4" drive, size: Hex 5 x 89 mm, hardened, suitable for holder according to DIN 3126-F 6.3/ISO 1173

Phoenix Contact 2020 © - all rights reserved
<http://www.phoenixcontact.com>

PHOENIX CONTACT GmbH & Co. KG
Flachsmarktstr. 8
32825 Blomberg
Germany
Tel. +49 5235 300
Fax +49 5235 3 41200
<http://www.phoenixcontact.com>

Mouser Electronics

Authorized Distributor

Click to View Pricing, Inventory, Delivery & Lifecycle Information:

[Phoenix Contact:](#)

[1404224](#)