

Jul.1.2020 Copyright 2020 HIROSE ELECTRIC CO., LTD. All Rights Reserved.
 In case of consideration for using Automotive equipment / device which demand high reliability, kindly contact our sales window correspondents.

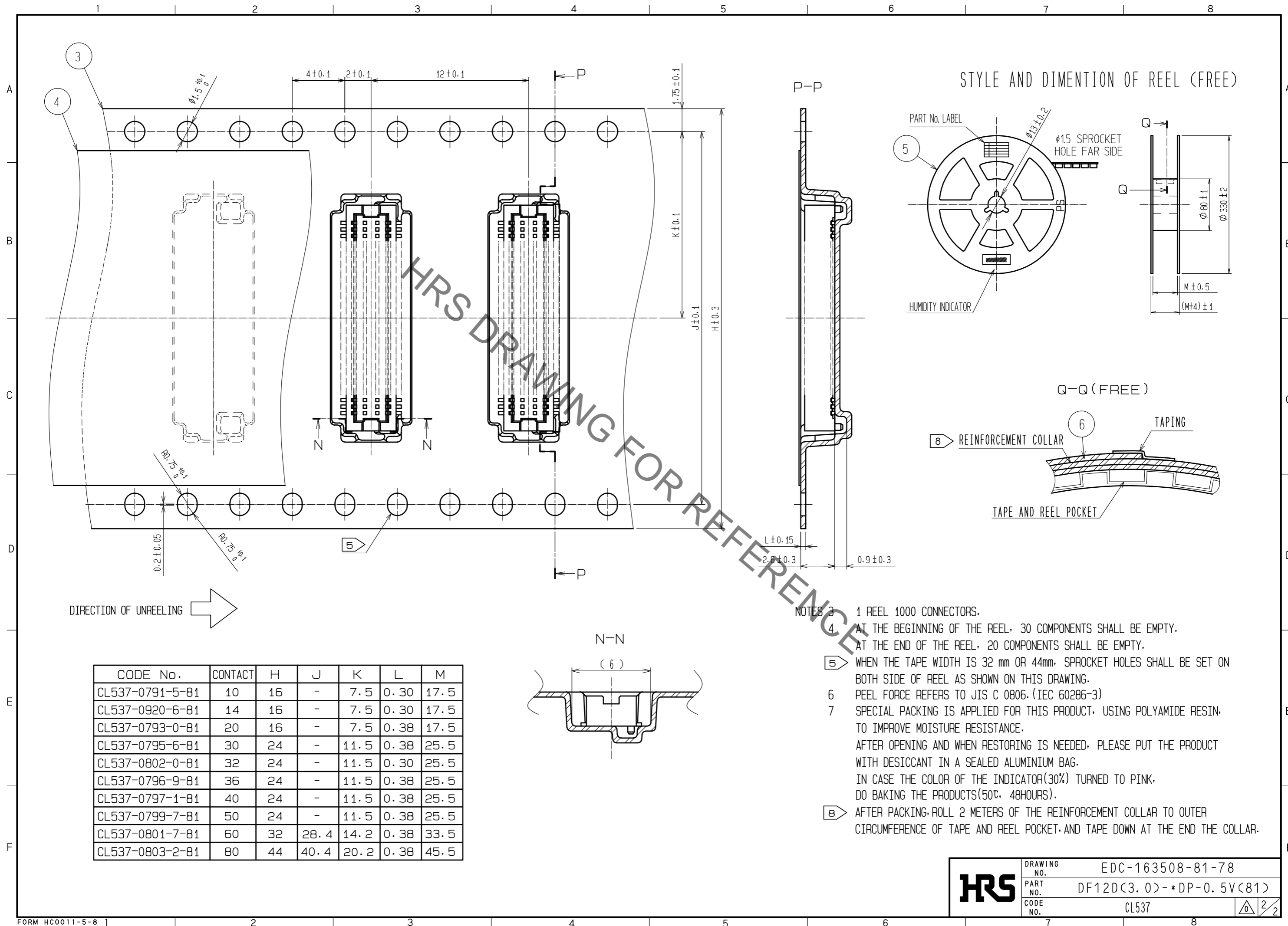

CODE No.	CONTACT	H	J	K	L	M
CL537-0791-5-81	10	16	-	7.5	0.30	17.5
CL537-0920-6-81	14	16	-	7.5	0.30	17.5
CL537-0793-0-81	20	16	-	7.5	0.38	17.5
CL537-0795-6-81	30	24	-	11.5	0.38	25.5
CL537-0802-0-81	32	24	-	11.5	0.30	25.5
CL537-0796-9-81	36	24	-	11.5	0.38	25.5
CL537-0797-1-81	40	24	-	11.5	0.38	25.5
CL537-0799-7-81	50	24	-	11.5	0.38	25.5
CL537-0801-7-81	60	32	28.4	14.2	0.38	33.5
CL537-0803-2-81	80	44	40.4	20.2	0.38	45.5

- NOTES
- 3 1 REEL 1000 CONNECTORS.
 - 4 AT THE BEGINNING OF THE REEL, 30 COMPONENTS SHALL BE EMPTY.
AT THE END OF THE REEL, 20 COMPONENTS SHALL BE EMPTY.
 - 5 WHEN THE TAPE WIDTH IS 32 mm OR 44mm, SPROCKET HOLES SHALL BE SET ON BOTH SIDE OF REEL AS SHOWN ON THIS DRAWING.
 - 6 PEEL FORCE REFERS TO JIS C 0806. (IEC 60286-3)
 - 7 SPECIAL PACKING IS APPLIED FOR THIS PRODUCT, USING POLYAMIDE RESIN, TO IMPROVE MOISTURE RESISTANCE.
AFTER OPENING AND WHEN RESTORING IS NEEDED, PLEASE PUT THE PRODUCT WITH DESICCANT IN A SEALED ALUMINIUM BAG.
IN CASE THE COLOR OF THE INDICATOR(30%) TURNED TO PINK, DO BAKING THE PRODUCTS(50°C, 48HOURS).
 - 8 AFTER PACKING, ROLL 2 METERS OF THE REINFORCEMENT COLLAR TO OUTER CIRCUMFERENCE OF TAPE AND REEL POCKET, AND TAPE DOWN AT THE END THE COLLAR.

HRS	DRAWING NO.	EDC-163508-81-78
	PART NO.	DF12D(3.0)-*DP-0.5V(81)
	CODE NO.	CL537
		2/2

Mouser Electronics

Authorized Distributor

Click to View Pricing, Inventory, Delivery & Lifecycle Information:

[Hirose Electric:](#)

[DF12D\(3.0\)-50DP-0.5V\(81\)](#)