

## TABLE OF CONTENTS

Features .....	1	Jitter Generation .....	13
Applications .....	1	Jitter Transfer .....	13
General Description .....	1	Jitter Tolerance .....	13
Functional Block Diagram .....	1	Theory of Operation .....	14
Revision History .....	2	Functional Description .....	16
Specifications .....	3	Frequency Acquisition .....	16
Jitter Specifications .....	4	Limiting Amplifier .....	16
Output and Timing Specifications .....	5	Slice Adjust .....	16
Absolute Maximum Ratings .....	6	LOS Detector .....	16
Thermal Characteristics .....	6	Lock Detector Operation .....	16
ESD Caution .....	6	Harmonic Detector .....	17
Timing Characteristics .....	7	Squelch Mode .....	17
Pin Configuration and Function Descriptions .....	8	I <sup>2</sup> C Interface .....	18
Typical Performance Characteristics .....	9	Reference Clock (Optional) .....	18
I <sup>2</sup> C Interface Timing and Internal Register Description .....	10	Applications Information .....	21
Terminology .....	12	PCB Design Guidelines .....	21
Input Sensitivity and Input Overdrive .....	12	DC-Coupled Application .....	23
Single-Ended vs. Differential .....	12	Coarse Data Rate Readback Look-Up Table .....	24
LOS Response Time .....	12	Outline Dimensions .....	26
Jitter Specifications .....	13	Ordering Guide .....	26

## REVISION HISTORY

<b>3/12—Rev. D to Rev. E</b>		Changes to LTR Mode Description .....	19
Updated Outline Dimensions .....	26	Changes to Ordering Guide .....	26
Changes to Ordering Guide .....	26	<b>11/04—Rev. 0 to Rev. A</b>	
<b>5/10—Rev. C to Rev. D</b>		Change to Specification .....	3
Changes to Figure 4, Table 5 .....	8	Updated Outline Dimensions .....	26
Changes to Figure 24 .....	21	Changes to Using the Reference Clock to Lock onto Data Section .....	19
<b>2/09—Rev. B to Rev. C</b>		<b>3/04—Revision 0: Initial Version</b>	
Updated Outline Dimensions .....	26		
Changes to Ordering Guide .....	26		
<b>6/07—Rev. A to Rev. B</b>			
Changes to Table 1 .....	3		
Changes to Table 6 .....	11		

## SPECIFICATIONS

$T_A = T_{MIN}$  to  $T_{MAX}$ ,  $V_{CC} = V_{MIN}$  to  $V_{MAX}$ ,  $V_{EE} = 0$  V,  $C_F = 0.47$   $\mu$ F,  $SLICEP = SLICEN = V_{EE}$ , input data pattern: PRBS  $2^{23} - 1$ , unless otherwise noted.

Table 1.

Parameter	Conditions	Min	Typ	Max	Unit
<b>QUANTIZER—DC CHARACTERISTICS</b>					
Input Voltage Range	@ PIN or NIN, dc-coupled	1.8		2.8	V
Peak-to-Peak Differential Input	PIN – NIN			2.0	V
Input Common-Mode Level	DC-coupled (see Figure 28, Figure 29, and Figure 30)	2.3	2.5	2.8	V
Differential Input Sensitivity	$2^{23} - 1$ PRBS, ac-coupled, <sup>1</sup> BER = $1 \times 10^{-10}$	10	6		mV p-p
Input Overdrive	(see Figure 12)	5	3		mV p-p
Input Offset			500		$\mu$ V
Input RMS Noise	BER = $1 \times 10^{-10}$		290		$\mu$ V rms
<b>QUANTIZER—AC CHARACTERISTICS</b>					
Data Rate		12.3		2700	Mb/s
S11	@ 2.5 GHz		-15		dB
Input Resistance	Differential		100		$\Omega$
Input Capacitance			0.65		pF
<b>QUANTIZER—SLICE ADJUSTMENT</b>					
Gain	SLICEP – SLICEN = $\pm 0.5$ V	0.08	0.1	0.125	V/V
Differential Control Voltage Input	SLICEP – SLICEN	-0.95		+0.95	V
Control Voltage Range	DC level @ SLICEP or SLICEN	VEE		0.95	V
Slice Threshold Offset			1		mV
<b>LOSS OF SIGNAL DETECT (LOS)</b>					
Loss of Signal Detect Range	$R_{Thresh} = 0 \Omega$ (see Figure 5)	11	13	17	mV
	$R_{Thresh} = 100$ k $\Omega$	1.5	3	4.0	mV
Hysteresis (Electrical)	OC-48				
	$R_{Thresh} = 0 \Omega$	5.6	6	7.2	dB
	$R_{Thresh} = 100$ k $\Omega$	3.7	6	8.4	dB
	OC-1				
	$R_{Thresh} = 0 \Omega$	5.6	6	7.2	dB
	$R_{Thresh} = 10$ k $\Omega$	2.0	4	6.7	dB
LOS Assert Time	DC-coupled <sup>2</sup>		500		ns
LOS Deassert Time	DC-coupled <sup>2</sup>		450		ns
<b>LOSS OF LOCK DETECT (LOL)</b>					
VCO Frequency Error for LOL Assert	With respect to nominal		1000		ppm
VCO Frequency Error for LOL Deassert	With respect to nominal		250		ppm
LOL Response Time	12.3 Mb/s		4		ms
	OC-12		1.0		$\mu$ s
	OC-48		1.0		$\mu$ s
<b>ACQUISITION TIME</b>					
Lock to Data Mode	OC-48		1.3		ms
	OC-12		2.0		ms
	OC-3		3.4		ms
	OC-1		9.8		ms
	12.3 Mb/s		40.0		ms
Optional Lock to REFCLK Mode			10.0		ms

Parameter	Conditions	Min	Typ	Max	Unit
DATA RATE READBACK ACCURACY					
Coarse Readback	See Table 14		10		%
Fine Readback	In addition to REFCLK accuracy Data rate ≤ 20 Mb/s Data rate > 20 Mb/s			200 100	ppm ppm
POWER SUPPLY VOLTAGE		3.0	3.3	3.6	V
POWER SUPPLY CURRENT			235	259	mA
OPERATING TEMPERATURE RANGE		-40		+85	°C

<sup>1</sup> PIN and NIN should be differentially driven and ac-coupled for optimum sensitivity.

<sup>2</sup> When ac-coupled, the LOS assert and deassert time is dominated by the RC time constant of the ac coupling capacitor and the 50 Ω input termination of the ADN2812 input stage.

## JITTER SPECIFICATIONS

T<sub>A</sub> = T<sub>MIN</sub> to T<sub>MAX</sub>, VCC = V<sub>MIN</sub> to V<sub>MAX</sub>, VEE = 0 V, C<sub>F</sub> = 0.47 μF, SLICEP = SLICEN = VEE, input data pattern: PRBS 2<sup>23</sup> - 1, unless otherwise noted.

**Table 2.**

Parameter	Conditions	Min	Typ	Max	Unit
PHASE-LOCKED LOOP CHARACTERISTICS					
Jitter Transfer BW	OC-48		490	670	kHz
	OC-12		71	108	kHz
	OC-3		23	35	kHz
Jitter Peaking	OC-48		0	0.03	dB
	OC-12		0	0.03	dB
	OC-3		0	0.03	dB
Jitter Generation	OC-48, 12 kHz to 20 MHz		0.001	0.002	UI rms
			0.02	0.037	UI p-p
	OC-12, 12 kHz to 5 MHz		0.001	0.002	UI rms
			0.01	0.019	UI p-p
	OC-3, 12 kHz to 1.3 MHz		0.001	0.002	UI rms
			0.01	0.011	UI p-p
Jitter Tolerance	OC-48, 2 <sup>23</sup> - 1 PRBS				
	600 Hz	70	92		UI p-p
	6 kHz	19	45		UI p-p
	100 kHz	3.8	5		UI p-p
	1 MHz	0.75	1		UI p-p
	20 MHz	0.4	0.6		UI p-p
	OC-12, 2 <sup>23</sup> - 1 PRBS				
	30 Hz <sup>1</sup>	100			UI p-p
	300 Hz <sup>1</sup>	44			UI p-p
	25 kHz	2.5			UI p-p
	250 kHz <sup>1</sup>	1.0			UI p-p
	OC-3, 2 <sup>23</sup> - 1 PRBS				
	30 Hz <sup>1</sup>	50			UI p-p
	300 Hz <sup>1</sup>	24			UI p-p
	6500 Hz	3.5			UI p-p
	65 kHz	1.0			UI p-p

<sup>1</sup> Jitter tolerance of the ADN2812 at these jitter frequencies is better than what the test equipment is able to measure.

## OUTPUT AND TIMING SPECIFICATIONS

Table 3.

Parameter	Conditions	Min	Typ	Max	Unit
<b>CML OUPUT CHARACTERISTICS</b> (CLKOUTP/CLKOUTN, DATAOUTP/DATAOUTN)					
Single-Ended Output Swing	$V_{SE}$ (see Figure 3)	300	350	600	mV
Differential Output Swing	$V_{DIFF}$ (see Figure 3)	600	700	1200	mV
Output High Voltage	$V_{OH}$			VCC	V
Output Low Voltage	$V_{OL}$	VCC – 0.6	VCC – 0.35	VCC – 0.3	V
<b>CML Outputs Timing</b>					
Rise Time	20% to 80%		95	112	ps
Fall Time	80% to 20%		95	123	ps
Setup Time	$t_s$ (see Figure 2), OC-48	150	200	250	ps
Hold Time	$t_H$ (see Figure 2), OC-48	150	200	250	ps
<b>I<sup>2</sup>C® INTERFACE DC CHARACTERISTICS</b>					
Input High Voltage	$V_{IH}$	0.7 VCC			V
Input Low Voltage	$V_{IL}$			0.3 VCC	V
Input Current	$V_{IN} = 0.1 VCC$ or $V_{IN} = 0.9 VCC$	–10.0		+10.0	μA
Output Low Voltage	$V_{OL}, I_{OL} = 3.0 mA$			0.4	V
<b>I<sup>2</sup>C INTERFACE TIMING</b>					
SCK Clock Frequency	See Figure 11			400	kHz
SCK Pulse Width High	$t_{HIGH}$	600			ns
SCK Pulse Width Low	$t_{LOW}$	1300			ns
Start Condition Hold Time	$t_{HD,STA}$	600			ns
Start Condition Setup Time	$t_{SU,STA}$	600			ns
Data Setup Time	$t_{SU,DAT}$	100			ns
Data Hold Time	$t_{HD,DAT}$	300			ns
SCK/SDA Rise/Fall Time	$t_r/t_f$	$20 + 0.1 C_b^1$		300	ns
Stop Condition Setup Time	$t_{SU,STO}$	600			ns
Bus Free Time Between a Stop and a Start	$t_{BUF}$	1300			ns
<b>REFCLK CHARACTERISTICS</b>					
Input Voltage Range	Optional lock to REFCLK mode @ REFCLKP or REFCLKN		0		V
	$V_{IL}$		VCC		V
	$V_{IH}$		100		mV p-p
Minimum Differential Input Drive				200	MHz
Reference Frequency		12.3			ppm
Required Accuracy			100		
<b>LVTTTL DC INPUT CHARACTERISTICS</b>					
Input High Voltage	$V_{IH}$	2.0			V
Input Low Voltage	$V_{IL}$			0.8	V
Input High Current	$I_{IH}, V_{IN} = 2.4 V$			5	μA
Input Low Current	$I_{IL}, V_{IN} = 0.4 V$	–5			μA
<b>LVTTTL DC OUTPUT CHARACTERISTICS</b>					
Output High Voltage	$V_{OH}, I_{OH} = -2.0 mA$	2.4			V
Output Low Voltage	$V_{OL}, I_{OL} = +2.0 mA$			0.4	V

<sup>1</sup> C<sub>b</sub> = total capacitance of one bus line in pF. If mixed with HS mode devices, faster fall-times are allowed (see Table 6).

## ABSOLUTE MAXIMUM RATINGS

$T_A = T_{MIN}$  to  $T_{MAX}$ ,  $V_{CC} = V_{MIN}$  to  $V_{MAX}$ ,  $V_{EE} = 0\text{ V}$ ,  $C_F = 0.47\ \mu\text{F}$ ,  
 $SLICEP = SLICEN = V_{EE}$ , unless otherwise noted.

Table 4.

Parameter	Rating
Supply Voltage (VCC)	4.2 V
Minimum Input Voltage (All Inputs)	$V_{EE} - 0.4\text{ V}$
Maximum Input Voltage (All Inputs)	$V_{CC} + 0.4\text{ V}$
Maximum Junction Temperature	125°C
Storage Temperature	-65°C to +150°C
Lead Temperature (Soldering 10 s)	300°C

Stresses above those listed under Absolute Maximum Ratings may cause permanent damage to the device. This is a stress rating only; functional operation of the device at these or any other conditions above those indicated in the operational section of this specification is not implied. Exposure to absolute maximum rating conditions for extended periods may affect device reliability.

## THERMAL CHARACTERISTICS

### Thermal Resistance

32-LFCSP, 4-layer board with exposed paddle soldered to VEE  
 $\theta_{JA} = 28^\circ\text{C/W}$ .

## ESD CAUTION



**ESD (electrostatic discharge) sensitive device.** Charged devices and circuit boards can discharge without detection. Although this product features patented or proprietary protection circuitry, damage may occur on devices subjected to high energy ESD. Therefore, proper ESD precautions should be taken to avoid performance degradation or loss of functionality.

# TIMING CHARACTERISTICS

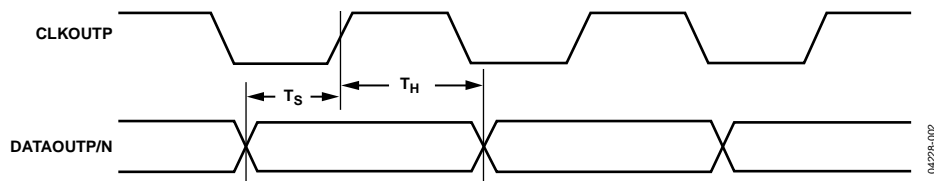

Figure 2. Output Timing

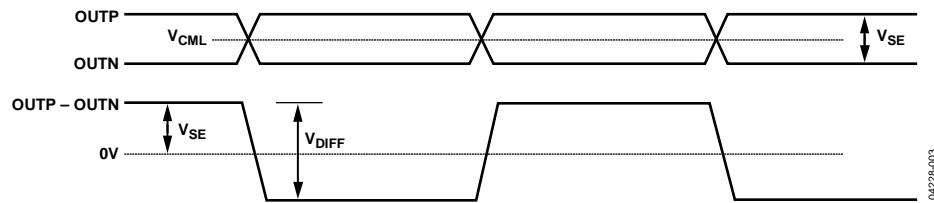
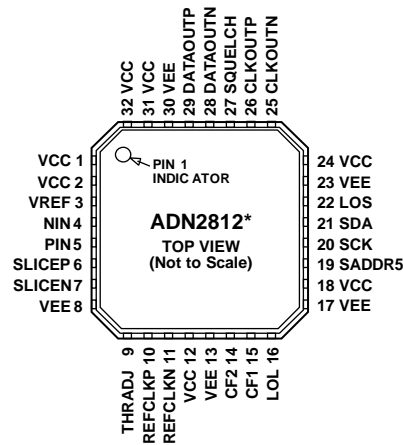

Figure 3. Single-Ended vs. Differential Output Specifications

## PIN CONFIGURATION AND FUNCTION DESCRIPTIONS



\*THERE IS AN EXPOSED PAD ON THE BOTTOM OF THE PACKAGE THAT MUST BE CONNECTED TO GND.

Figure 4. Pin Configuration

Table 5. Pin Function Descriptions

Pin No.	Mnemonic	Type <sup>1</sup>	Description
1	VCC	AI	Connect to VCC.
2	VCC	P	Power for Limamp, LOS.
3	VREF	AO	Internal VREF Voltage. Decouple to GND with a 0.1 $\mu$ F capacitor.
4	NIN	AI	Differential Data Input. CML.
5	PIN	AI	Differential Data Input. CML.
6	SLICEP	AI	Differential Slice Level Adjust Input.
7	SLICEN	AI	Differential Slice Level Adjust Input.
8	VEE	P	GND for Limamp, LOS.
9	THRADJ	AI	LOS Threshold Setting Resistor.
10	REFCLKP	DI	Differential REFCLK Input. 12.3 MHz to 200 MHz.
11	REFCLKN	DI	Differential REFCLK Input. 12.3 MHz to 200 MHz.
12	VCC	P	VCO Power.
13	VEE	P	VCO GND.
14	CF2	AO	Frequency Loop Capacitor.
15	CF1	AO	Frequency Loop Capacitor.
16	LOL	DO	Loss of Lock Indicator. LVTTTL active high.
17	VEE	P	FLL Detector GND.
18	VCC	P	FLL Detector Power.
19	SADDR5	DI	Slave Address Bit 5.
20	SCK	DI	I <sup>2</sup> C Clock Input.
21	SDA	DI	I <sup>2</sup> C Data Input.
22	LOS	DO	Loss of Signal Detect Output. Active high. LVTTTL.
23	VEE	P	Output Buffer, I <sup>2</sup> C GND.
24	VCC	P	Output Buffer, I <sup>2</sup> C Power.
25	CLKOUTN	DO	Differential Recovered Clock Output. CML.
26	CLKOUTP	DO	Differential Recovered Clock Output. CML.
27	SQUELCH	DI	Disable Clock and Data Outputs. Active high. LVTTTL.
28	DATAOUTN	DO	Differential Recovered Data Output. CML.
29	DATAOUTP	DO	Differential Recovered Data Output. CML.
30	VEE	P	Phase Detector, Phase Shifter GND.
31	VCC	P	Phase Detector, Phase Shifter Power.
32	VCC	AI	Connect to VCC.
Exposed Pad	Pad	P	Connect to GND. Works as a heat sink.

<sup>1</sup> P = power, AI = analog input, AO = analog output, DI = digital input, DO = digital output.

### TYPICAL PERFORMANCE CHARACTERISTICS

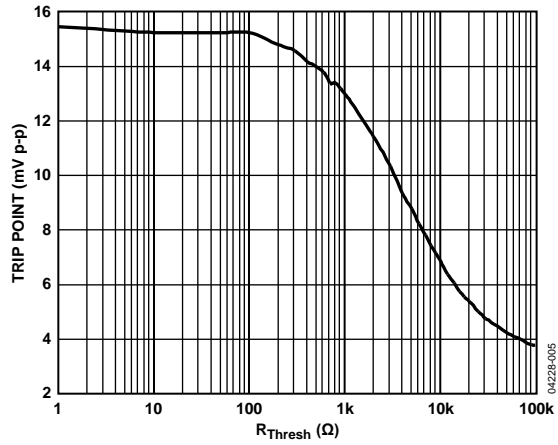

Figure 5. LOS Comparator Trip Point Programming

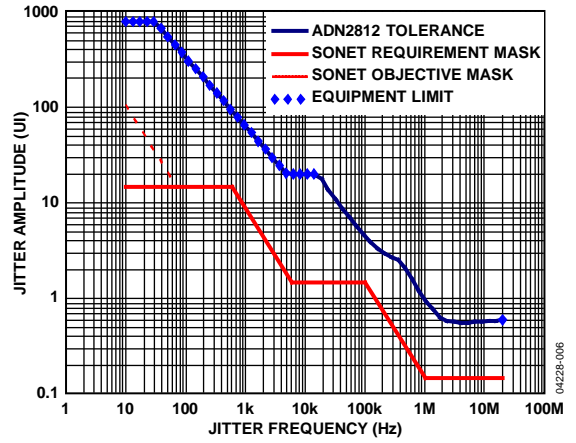

Figure 6. Typical Measured Jitter Tolerance OC-48





Table 6. Internal Register Map<sup>1</sup>

Reg. Name	R/W	Address	D7	D6	D5	D4	D3	D2	D1	D0	
FREQ0	R	0x00	MSB							LSB	
FREQ1	R	0x01	MSB							LSB	
FREQ2	R	0x02	0	MSB						LSB	
RATE	R	0x03	COARSE_RD[8] MSB				Coarse data rate readback			COARSE_RD[1]	
MISC	R	0x04	x	x	LOS status	Static LOL	LOL status	Data rate measure complete	x	COARSE_RD[0] LSB	
CTRLA	W	0x08	F <sub>REF</sub> range		Data rate/DIV <sub>FREF</sub> ratio				Measure data rate	Lock to reference	
CTRLA_RD	R	0x05	Readback CTRLA contents								
CTRLB	W	0x09	Config LOL	Reset MISC[4]	System reset	0	Reset MISC[2]	0	0	0	
CTRLB_RD	R	0x06	Readback CTRLB contents								
CTRLC	W	0x11	0	0	0	0	0	Config LOS	Squelch mode	0	

<sup>1</sup>All writeable registers default to 0x00.

Table 7. Miscellaneous Register, MISC

		LOS Status	Static LOL	LOL Status	Data Rate Measurement Complete		Coarse Rate Readback LSB
D7	D6	D5	D4	D3	D2	D1	D0
x	x	0 = No loss of signal 1 = Loss of signal	0 = Waiting for next LOL 1 = Static LOL until reset	0 = Locked 1 = Acquiring	0 = Measuring data rate 1 = Measurement complete	x	COARSE_RD[0]

Table 8. Control Register, CTRLA<sup>1</sup>

F <sub>REF</sub> Range		Data Rate/DIV <sub>FREF</sub> Ratio	Measure Data Rate		Lock to Reference				
D7	D6	D5 D4 D3 D2	D1		D0				
0	0	12.3 MHz to 25 MHz	0	0	0	1	Set to 1 to measure data rate	0 = Lock to input data 1 = Lock to reference clock	
0	1	25 MHz to 50 MHz	0	0	0	1			2
1	0	50 MHz to 100 MHz	0	0	1	0			4
1	1	100 MHz to 200 MHz	n		2 <sup>n</sup>				256

<sup>1</sup>Where DIV<sub>FREF</sub> is the divided down reference referred to the 12.3 MHz to 25 MHz band (see the Reference Clock (Optional) section).

Table 9. Control Register, CTRLB

Config LOL	Reset MISC[4]	System Reset		Reset MISC[2]			
D7	D6	D5	D4	D3	D2	D1	D0
0 = LOL pin normal operation 1 = LOL pin is static LOL	Write a 1 followed by 0 to reset MISC[4]	Write a 1 followed by 0 to reset ADN2812	Set to 0	Write a 1 followed by 0 to reset MISC[2]	Set to 0	Set to 0	Set to 0

Table 10. Control Register, CTRLC

		Config LOS			Squelch Mode		
D7	D6	D5	D4	D3	D2	D1	D0
Set to 0	Set to 0	Set to 0	Set to 0	Set to 0	0 = Active high LOS 1 = Active low LOS	0 = Squelch CLK and DATA 1 = Squelch CLK or DATA	Set to 0

## TERMINOLOGY

### INPUT SENSITIVITY AND INPUT OVERDRIVE

Sensitivity and overdrive specifications for the quantizer involve offset voltage, gain, and noise. The relationship between the logic output of the quantizer and the analog voltage input is shown in Figure 12. For sufficiently large positive input voltage, the output is always at Logic Level 1 and, similarly for negative inputs, the output is always at Logic Level 0. However, the output transitions between Logic Level 1 and Logic Level 0 are not at precisely defined input voltage levels but occur over a range of input voltages. Within this range of input voltages, the output might be either 1 or 0, or it might even fail to attain a valid logic state. The width of this zone is determined by the input voltage noise of the quantizer. The center of the zone is the quantizer input offset voltage. Input overdrive is the magnitude of signal required to guarantee the correct logic level with  $1 \times 10^{-10}$  confidence level.

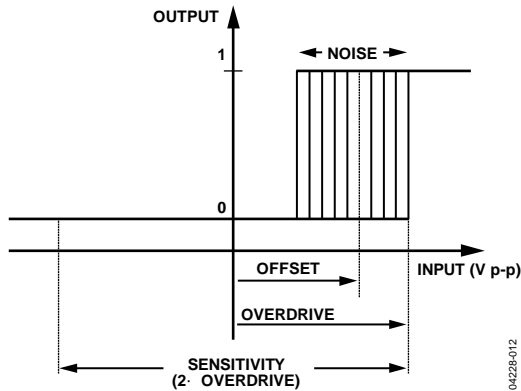

Figure 12. Input Sensitivity and Input Overdrive

### SINGLE-ENDED VS. DIFFERENTIAL

AC coupling is typically used to drive the inputs to the quantizer. The inputs are internally dc biased to a common-mode potential of  $\sim 2.5$  V. Driving the ADN2812 single-ended and observing the quantizer input with an oscilloscope probe at the point indicated in Figure 13 show a binary signal with an average value equal to the common-mode potential and instantaneous values both above and below the average value. It is convenient to measure the peak-to-peak amplitude of this signal and call the minimum required value the quantizer sensitivity. Referring to Figure 13, because both positive and negative offsets need to be accommodated, the sensitivity is twice the overdrive. The ADN2812 quantizer typically has 6 mV p-p sensitivity.

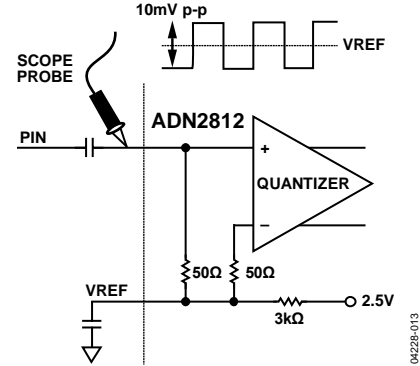

Figure 13. Single-Ended Sensitivity Measurement

While driving the ADN2812 differentially (see Figure 14), sensitivity seems to improve from observing the quantizer input with an oscilloscope probe. This is an illusion caused by the use of a single-ended probe. A 5 mV p-p signal appears to drive the ADN2812 quantizer. However, the single-ended probe measures only half the signal. The true quantizer input signal is twice this value because the other quantizer input is a complementary signal to the signal being observed.

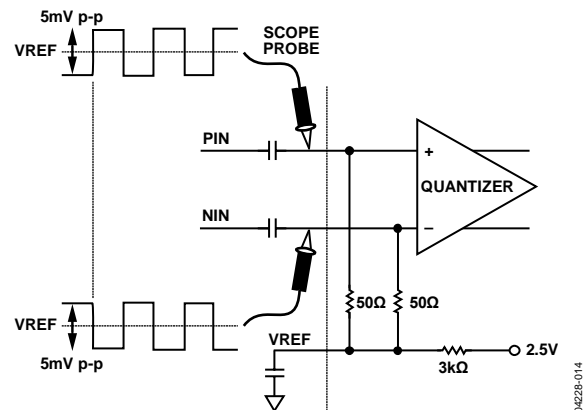

Figure 14. Differential Sensitivity Measurement

### LOS RESPONSE TIME

Loss of signal (LOS) response time is the delay between removal of the input signal and indication of LOS at the LOS output, Pin 22. When the inputs are dc-coupled, the LOS assert time of the ADN2812 is 500 ns typically and the deassert time is 400 ns typically. In practice, the time constant produced by the ac coupling at the quantizer input and the 50 Ω on-chip input termination determines the LOS response time.

### JITTER SPECIFICATIONS

The ADN2812 CDR is designed to achieve the best bit-error-rate (BER) performance and exceeds the jitter transfer, generation, and tolerance specifications proposed for SONET/SDH equipment defined in the Telcordia Technologies GR-253-CORE document.

Jitter is the dynamic displacement of digital signal edges from their long-term average positions, measured in unit intervals (UI), where 1 UI = 1 bit period. Jitter on the input data can cause dynamic phase errors on the recovered clock sampling edge. Jitter on the recovered clock causes jitter on the retimed data.

The following sections briefly summarize the specifications of jitter generation, jitter transfer, and jitter tolerance in accordance with the GR-253-CORE from Telcordia for the optical interface at the equipment level and the ADN2812 performance with respect to those specifications.

#### JITTER GENERATION

The jitter generation specification limits the amount of jitter that can be generated by the device with no jitter and wander applied at the input. For OC-48 devices, the band-pass filter has a 12 kHz high-pass cutoff frequency with a roll-off of 20 dB/decade and a low-pass cutoff frequency of at least 20 MHz. The jitter generated must be less than 0.01 UI rms and must be less than 0.1 UI p-p.

#### JITTER TRANSFER

The jitter transfer function is the ratio of the jitter on the output signal to the jitter applied on the input signal vs. the frequency. This parameter measures the limited amount of the jitter on an input signal that can be transferred to the output signal (see Figure 15).

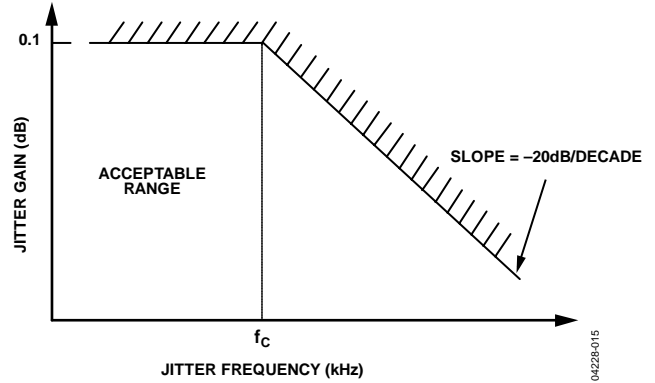

Figure 15. Jitter Transfer Curve

#### JITTER TOLERANCE

The jitter tolerance is defined as the peak-to-peak amplitude of the sinusoidal jitter applied on the input signal, which causes a 1 dB power penalty. This is a stress test to ensure that no additional penalty is incurred under the operating conditions (see Figure 16).

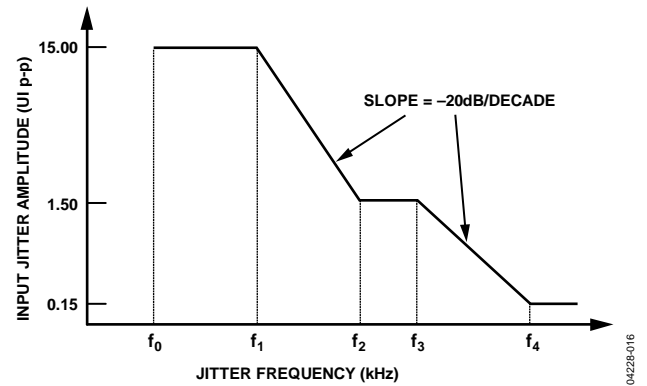

Figure 16. SONET Jitter Tolerance Mask

## THEORY OF OPERATION

The ADN2812 is a delay- and phase-locked loop circuit for clock recovery and data retiming from an NRZ encoded data stream. The phase of the input data signal is tracked by two separate feedback loops that share a common control voltage. A high speed delay-locked loop path uses a voltage controlled phase shifter to track the high frequency components of input jitter. A separate phase control loop, comprised of the VCO, tracks the low frequency components of input jitter. The initial frequency of the VCO is set by yet a third loop, which compares the VCO frequency with the input data frequency and sets the coarse tuning voltage. The jitter tracking phase-locked loop controls the VCO by the fine-tuning control.

The delay- and phase-loops together track the phase of the input data signal. For example, when the clock lags input data, the phase detector drives the VCO to a higher frequency and also increases the delay through the phase shifter; both these actions serve to reduce the phase error between the clock and data. The faster clock picks up phase, while the delayed data loses phase. Because the loop filter is an integrator, the static phase error is driven to zero.

Another view of the circuit is that the phase shifter implements the zero required for frequency compensation of a second-order, phase-locked loop. This zero is placed in the feedback path and, thus, does not appear in the closed-loop transfer function. Jitter peaking in a conventional second-order phase-locked loop is caused by the presence of this zero in the closed-loop transfer function. Because this circuit has no zero in the closed-loop transfer, jitter peaking is minimized.

The delay- and phase-loops together simultaneously provide wide-band jitter accommodation and narrow-band jitter filtering. The linearized block diagram in Figure 17 shows that the jitter transfer function,  $Z(s)/X(s)$ , is a second-order low-pass providing excellent filtering. Note that the jitter transfer has no zero, unlike an ordinary second-order phase-locked loop. This means that the main PLL loop has virtually zero jitter peaking (see Figure 18), making this circuit ideal for signal regenerator applications, where jitter peaking in a cascade of regenerators can contribute to hazardous jitter accumulation.

The error transfer,  $e(s)/X(s)$ , has the same high-pass form as an ordinary phase-locked loop. This transfer function is free to be optimized to give excellent wide-band jitter accommodation because the jitter transfer function,  $Z(s)/X(s)$ , provides the narrow-band jitter filtering.

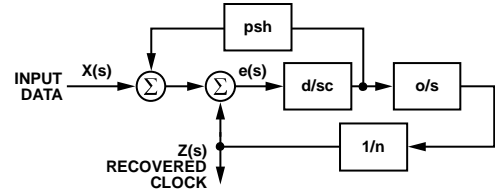

d = PHASE DETECTOR GAIN  
o = VCO GAIN  
c = LOOP INTEGRATOR  
psh = PHASE SHIFTER GAIN  
n = DIVIDE RATIO

**JITTER TRANSFER FUNCTION**

$$\frac{Z(s)}{X(s)} = \frac{1}{s^2 \frac{cn}{do} + s \frac{n \text{ psh}}{o} + 1}$$

**TRACKING ERROR TRANSFER FUNCTION**

$$\frac{e(s)}{X(s)} = \frac{s^2}{s^2 + s \frac{d \text{ psh}}{c} + \frac{do}{cn}}$$

Figure 17. PLL/DLL Architecture

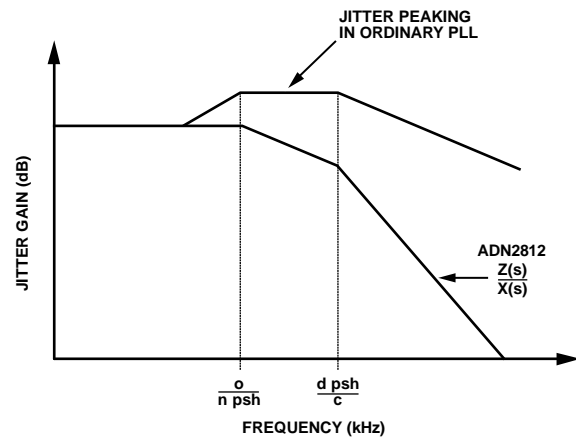

Figure 18. Jitter Response vs. Conventional PLL

The delay- and phase-loops contribute to overall jitter accommodation. At low frequencies of input jitter on the data signal, the integrator in the loop filter provides high gain to track large jitter amplitudes with small phase error. In this case, the VCO is frequency modulated and jitter is tracked as in an ordinary phase-locked loop. The amount of low frequency jitter that can be tracked is a function of the VCO tuning range. A wider tuning range gives larger accommodation of low frequency jitter. The internal loop control voltage remains small for small phase errors, so the phase shifter remains close to the center of its range and thus contributes little to the low frequency jitter accommodation.

At medium jitter frequencies, the gain and tuning range of the VCO are not large enough to track input jitter. In this case, the VCO control voltage becomes large and saturates, and the VCO frequency dwells at one extreme of its tuning range or the other. The size of the VCO tuning range, therefore, has only a small effect on the jitter accommodation. The delay-locked loop control voltage is now larger, so the phase shifter takes on the burden of tracking the input jitter. The phase shifter range, in UI, can be seen as a broad plateau on the jitter tolerance curve. The phase shifter has a minimum range of 2 UI at all data rates. The gain of the loop integrator is small for high jitter frequencies so that larger phase differences are needed to make the loop control voltage big enough to tune the range of the phase

shifter. Large phase errors at high jitter frequencies cannot be tolerated. In this region, the gain of the integrator determines the jitter accommodation. Because the gain of the loop integrator declines linearly with frequency, jitter accommodation is lower with higher jitter frequency. At the highest frequencies, the loop gain is very small, and little tuning of the phase shifter can be expected. In this case, jitter accommodation is determined by the eye opening of the input data, the static phase error, and the residual loop jitter generation. The jitter accommodation is roughly 0.5 UI in this region. The corner frequency between the declining slope and the flat region is the closed loop bandwidth of the delay-locked loop, which is roughly 3 MHz at OC-48.

## FUNCTIONAL DESCRIPTION

### FREQUENCY ACQUISITION

The ADN2812 acquires frequency from the data over a range of data frequencies from 12.3 Mb/s to 2.7 Gb/s. The lock detector circuit compares the frequency of the VCO and the frequency of the incoming data. When these frequencies differ by more than 1000 ppm, LOL is asserted. This initiates a frequency acquisition cycle. The VCO frequency is reset to the bottom of its range, which is 12.3 MHz. The frequency detector then compares this VCO frequency and the incoming data frequency and increments the VCO frequency, if necessary. Initially, the VCO frequency is incremented in large steps to aid fast acquisition. As the VCO frequency approaches the data frequency, the step size is reduced until the VCO frequency is within 250 ppm of the data frequency, at which point LOL is deasserted.

Once LOL is deasserted, the frequency-locked loop is turned off. The PLL/DLL pulls in the VCO frequency the rest of the way until the VCO frequency equals the data frequency.

The frequency loop requires a single external capacitor between CF2 and CF1 (Pin 14 and Pin 15). A  $0.47 \mu\text{F} \pm 20\%$ , X7R ceramic chip capacitor with  $<10 \text{ nA}$  leakage current is recommended. Leakage current of the capacitor can be calculated by dividing the maximum voltage across the  $0.47 \mu\text{F}$  capacitor,  $\sim 3 \text{ V}$ , by the insulation resistance of the capacitor. The insulation resistance of the  $0.47 \mu\text{F}$  capacitor should be greater than  $300 \text{ M}\Omega$ .

### LIMITING AMPLIFIER

The limiting amplifier has differential inputs (PIN/NIN), which are internally terminated with  $50 \Omega$  to an on-chip voltage reference ( $V_{\text{REF}} = 2.5 \text{ V}$  typically). The inputs are typically ac-coupled externally, although dc coupling is possible as long as the input common-mode voltage remains above  $2.5 \text{ V}$  (see Figure 28, Figure 29, and Figure 30). Input offset is factory trimmed to achieve better than  $6 \text{ mV}$  typical sensitivity with minimal drift. The limiting amplifier can be driven differentially or single-ended.

### SLICE ADJUST

The quantizer slicing level can be offset by  $\pm 100 \text{ mV}$  to mitigate the effect of amplified spontaneous emission (ASE) noise or duty cycle distortion by applying a differential voltage input of up to  $\pm 0.95 \text{ V}$  to the SLICEP/SLICEN inputs. If no adjustment of the slice level is needed, SLICEP/SLICEN should be tied to VEE. The gain of the slice adjustment is  $\sim 0.1 \text{ V/V}$ .

### LOS DETECTOR

The receiver front-end LOS detector circuit detects when the input signal level has fallen below a user-adjustable threshold. The threshold is set with a single external resistor from Pin 9 (THRADJ) to VEE. The LOS comparator trip point-vs.-resistor

value is illustrated in Figure 5. If the input level to the ADN2812 drops below the programmed LOS threshold, the output of the LOS detector, LOS (Pin 22), is asserted to a Logic 1. The LOS detector's response time is  $\sim 500 \text{ ns}$  by design but is dominated by the RC time constant in ac-coupled applications. The LOS pin defaults to active high. However, by setting Bit CTRLC[2] to 1, the LOS pin is configured as active low.

Typically, 6 dB of electrical hysteresis is designed into the LOS detector to prevent chatter on the LOS pin. This means that if the input level drops below the programmed LOS threshold causing the LOS pin to assert, the LOS pin is not deasserted until the input level increases to 6 dB ( $2\times$ ) above the LOS threshold (see Figure 19).

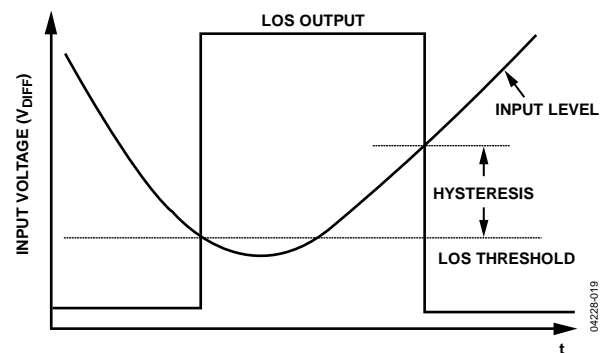

Figure 19. LOS Detector Hysteresis

The LOS detector and the SLICE level adjust can be used simultaneously on the ADN2812. This means that any offset added to the input signal by the SLICE adjust pins does not affect the LOS detector's measurement of the absolute input level.

### LOCK DETECTOR OPERATION

The lock detector on the ADN2812 has three modes of operation: normal mode, REFCLK mode, and static LOL mode.

#### Normal Mode

In normal mode, the ADN2812 is a continuous rate CDR that locks onto any data rate from 12.3 Mb/s to 2.7 Gb/s without the use of a reference clock as an acquisition aid. In this mode, the lock detector monitors the frequency difference between the VCO and the input data frequency and deasserts the loss of lock signal appearing on LOL (Pin 16) when the VCO is within 250 ppm of the data frequency. This enables the D/PLL, which pulls the VCO frequency in the remaining amount and also acquires phase lock. Once locked, if the input frequency error exceeds 1000 ppm (0.1%), the loss of lock signal is reasserted and control returns to the frequency loop, which begins a new frequency acquisition starting at the lowest point in the VCO operating range, 12.3 MHz. The LOL pin remains asserted until the VCO locks onto a valid input data stream to within 250 ppm frequency error. This hysteresis is shown in Figure 20.

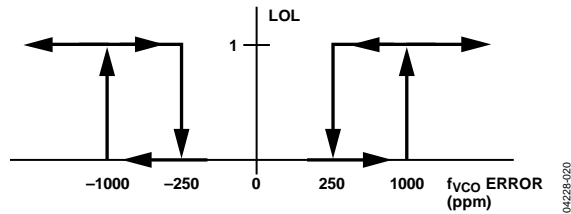

Figure 20. Transfer Function of LOL

### LOL Detector Operation Using a Reference Clock (REFCLK Mode)

In REFCLK mode, a reference clock is used as an acquisition aid to lock the ADN2812 VCO. Lock to reference mode is enabled by setting CTRLA[0] to 1. The user also needs to write to the CTRLA[7:6] and CTRLA[5:2] bits in order to set the reference frequency range and the divide ratio of the data rate with respect to the reference frequency. For more details, see the Reference Clock (Optional) section. In this mode, the lock detector monitors the difference in frequency between the divided down VCO and the divided down reference clock. The loss of lock signal, which appears on LOL (Pin 16), is deasserted when the VCO is within 250 ppm of the desired frequency. This enables the D/PLL, which pulls the VCO frequency in the remaining amount with respect to the input data and also acquires phase lock. Once locked, if the input frequency error exceeds 1000 ppm (0.1%), the loss of lock signal is reasserted and control returns to the frequency loop, which reacquires with respect to the reference clock. The LOL pin remains asserted until the VCO frequency is within 250 ppm of the desired frequency. This hysteresis is shown in Figure 20.

### Static LOL Mode

The ADN2812 implements a static LOL feature, which indicates if a loss of lock condition has ever occurred and remains asserted, even if the ADN2812 regains lock, until the static LOL bit is manually reset. The I<sup>2</sup>C register bit, MISC[4], is the static LOL bit. If there is ever an occurrence of a loss of lock condition, this bit is internally asserted to logic high. The MISC[4] bit remains high even after the ADN2812 has reacquired lock to a new data rate. This bit can be reset by writing a 1 followed by 0 to I<sup>2</sup>C Register Bit CTRLB[6]. Once reset, the MISC[4] bit remains deasserted until another loss of lock condition occurs.

Writing a 1 to I<sup>2</sup>C Register Bit CTRLB[7] causes the LOL pin (Pin 16) to become a static LOL indicator. In this mode, the LOL pin mirrors the contents of the MISC[4] bit and has the functionality described in the previous paragraph. The CTRLB[7] bit defaults to 0. In this mode, the LOL pin operates in the normal operating mode, that is, it is asserted only when the ADN2812 is in acquisition mode and deasserts when the ADN2812 has reacquired lock.

### HARMONIC DETECTOR

The ADN2812 provides a harmonic detector, which detects whether the input data has changed to a lower harmonic of the data rate onto which the VCO is currently locked. For example, if the input data instantaneously changes from OC-48, 2.488 Gb/s, to an OC-12, 622.080 Mb/s bit stream, this could be perceived as a valid OC-48 bit stream because the OC-12 data pattern is exactly 4× slower than the OC-48 pattern. So, if the change in data rate is instantaneous, a 101 pattern at OC-12 would be perceived by the ADN2812 as a 111100001111 pattern at OC-48. If the change to a lower harmonic is instantaneous, a typical CDR could remain locked at the higher data rate.

The ADN2812 implements a harmonic detector that automatically identifies whether the input data has switched to a lower harmonic of the data rate onto which the VCO is currently locked. When a harmonic is identified, the LOL pin is asserted and a new frequency acquisition is initiated. The ADN2812 automatically locks onto the new data rate, and the LOL pin is deasserted.

However, the harmonic detector does not detect higher harmonics of the data rate. If the input data rate switches to a higher harmonic of the data rate that the VCO is currently locked onto, the VCO loses lock, the LOL pin is asserted, and a new frequency acquisition is initiated. The ADN2812 automatically locks onto the new data rate.

The time to detect lock to harmonic is

$$16,384 \times (T_d/\rho)$$

where:

$1/T_d$  is the new data rate. For example, if the data rate is switched from OC-48 to OC-12, then  $T_d = 1/622$  MHz.  $\rho$  is the data transition density. Most coding schemes seek to ensure that  $\rho = 0.5$ , for example, PRBS, 8B/10B.

When the ADN2812 is placed in lock to reference mode, the harmonic detector is disabled.

### SQUELCH MODE

Two squelch modes are available with the ADN2812. Squelch DATAOUT and CLKOUT mode is selected when CTRLC[1] = 0 (default mode). In this mode, when the squelch input (Pin 27) is driven to a TTL high state, both the clock and data outputs are set to the zero state to suppress downstream processing. If the squelch function is not required, Pin 27 should be tied to VEE.

Squelch DATAOUT or CLKOUT mode is selected when CTRLC[1] is 1. In this mode, when the squelch input is driven to a high state, the DATAOUT pins are squelched. When the squelch input is driven to a low state, the CLKOUT pins are squelched. This is especially useful in repeater applications, where the recovered clock may not be needed.



## I<sup>2</sup>C INTERFACE

The ADN2812 supports a 2-wire, I<sup>2</sup>C-compatible, serial bus driving multiple peripherals. Two inputs, serial data (SDA) and serial clock (SCK), carry information between any devices connected to the bus. Each slave device is recognized by a unique address. The ADN2812 has two possible 7-bit slave addresses for both read and write operations. The MSB of the 7-bit slave address is factory programmed to 1. B5 of the slave address is set by Pin 19, SADDR5. Slave address Bits[4:0] are defaulted to all 0s. The slave address consists of the 7 MSBs of an 8-bit word. The LSB of the word sets either a read or write operation (see Figure 7). Logic 1 corresponds to a read operation, while Logic 0 corresponds to a write operation.

To control the device on the bus, the following protocol must be followed. The master initiates a data transfer by establishing a start condition, defined by a high to low transition on SDA while SCK remains high. This indicates that an address/data stream follows. All peripherals respond to the start condition and shift the next eight bits (the 7-bit address and the R/W bit). The bits are transferred from MSB to LSB. The peripheral that recognizes the transmitted address responds by pulling the data line low during the ninth clock pulse. This is known as an acknowledge bit. All other devices withdraw from the bus at this point and maintain an idle condition. The idle condition is where the device monitors the SDA and SCK lines waiting for the start condition and correct transmitted address. The R/W bit determines the direction of the data. Logic 0 on the LSB of the first byte means that the master writes information to the peripheral. Logic 1 on the LSB of the first byte means that the master reads information from the peripheral.

The ADN2812 acts as a standard slave device on the bus. The data on the SDA pin is 8 bits long supporting the 7-bit addresses plus the R/W bit. The ADN2812 has 8 subaddresses to enable the user-accessible internal registers (see Table 1 through Table 7). Therefore, it interprets the first byte as the device address and the second byte as the starting subaddress. Autoincrement mode is supported, allowing data to be read from or written to the starting subaddress and each subsequent address without manually addressing the subsequent subaddress. A data transfer is always terminated by a stop condition. The user can also access any unique subaddress register on a one-by-one basis without updating all registers.

Stop and start conditions can be detected at any stage of the data transfer. If these conditions are asserted out of sequence with normal read and write operations, they cause an immediate jump to the idle condition. During a given SCK high period, the user should issue one start condition, one stop condition, or a single stop condition followed by a single start condition. If an invalid subaddress is issued by the user, the ADN2812 does not issue an acknowledge and returns to the idle condition. If the user exceeds the highest subaddress while reading back in autoincrement mode, the highest

subaddress register contents continue to be output until the master device issues a no acknowledge. This indicates the end of a read. In a no acknowledge condition, the SDATA line is not pulled low on the ninth pulse. See Figure 8 and Figure 9 for sample write and read data transfers and Figure 10 for a more detailed timing diagram.

## REFERENCE CLOCK (OPTIONAL)

A reference clock is not required to perform clock and data recovery with the ADN2812. However, support for an optional reference clock is provided. The reference clock can be driven differentially or single-ended. If the reference clock is not being used, REFCLKP should be tied to VCC, and REFCLKN can be left floating or tied to VEE (the inputs are internally terminated to VCC/2). See Figure 21 through Figure 23 for sample configurations.

The REFCLK input buffer accepts any differential signal with a peak-to-peak differential amplitude of greater than 100 mV (for example, LVPECL or LVDS) or a standard single-ended low voltage TTL input, providing maximum system flexibility. Phase noise and duty cycle of the reference clock are not critical, and 100 ppm accuracy is sufficient.

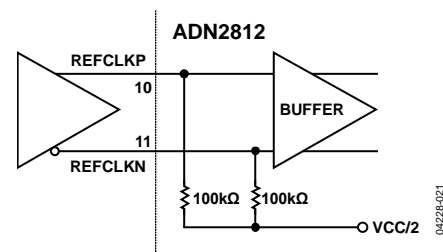

Figure 21. Differential REFCLK Configuration

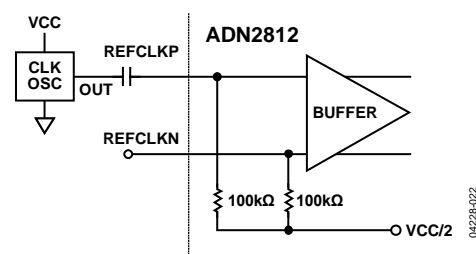

Figure 22. Single-Ended REFCLK Configuration

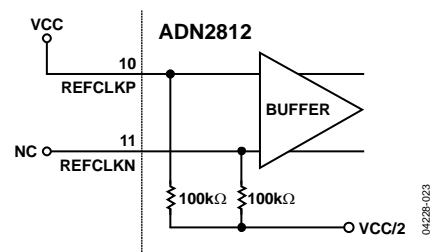

Figure 23. No REFCLK Configuration

The two uses of the reference clock are mutually exclusive. The reference clock can be used either as an acquisition aid for the ADN2812 to lock onto data or to measure the frequency of the incoming data to within 0.01%. (There is the capability to measure the data rate to approximately  $\pm 10\%$  without the use of a reference clock.) The modes are mutually exclusive because, in the first use, the user knows the exact data rate and wants to force the part to lock onto only that data rate; in the second use, the user does not know the data rate and wants to measure it.

Lock to reference mode is enabled by writing a 1 to I<sup>2</sup>C Register Bit CTRLA[0]. Fine data rate readback mode is enabled by writing a 1 to I<sup>2</sup>C Register Bit CTRLA[1]. Writing a 1 to both of these bits at the same time causes an indeterminate state and is not supported.

### Using the Reference Clock to Lock onto Data

Writing CTRLA[0] = 1 puts the ADN2812 into lock-to-REFCLK (LTR) mode. In this mode, the ADN2812 locks onto a frequency derived from the reference clock according to the following equation:

$$\text{Data Rate}/2^{\text{CTRLA}[5:2]} = \text{REFCLK}/2^{\text{CTRLA}[7:6]}$$

The user must know exactly what the data rate is and provide a reference clock that is a function of this rate. The ADN2812 can still be used as a continuous rate device in this configuration, provided that the user has the ability to provide a reference clock that has a variable frequency (see the Application Note AN-632).

The reference clock can be anywhere between 12.3 MHz and 200 MHz. By default, the ADN2812 expects a reference clock between 12.3 MHz and 25 MHz. If it is between 25 MHz and 50 MHz, 50 MHz and 100 MHz, or 100 MHz and 200 MHz, the user needs to configure the ADN2812 to use the correct reference frequency range by setting two bits of the CTRLA register, CTRLA[7:6].

**Table 11. CTRLA[7:6] Settings**

CTRLA[7:6]	Range (MHz)
00	12.3 to 25
01	25 to 50
10	50 to 100
11	100 to 200

**Table 12. CTRLA[5:2] Settings**

CTRLA[5:2]	Ratio
0000	1
0001	2
n	2 <sup>n</sup>
1000	256

The user can specify a fixed integer multiple of the reference clock to lock onto using CTRLA[5:2], where CTRLA is set to the data rate/DIV\_FREF and where DIV\_FREF represents the divided-down reference referred to the 12.3 MHz to 25 MHz band. For example, if the reference clock frequency is 38.88 MHz and the input data rate is 622.08 Mb/s, CTRLA[7:6] is set to [01] to give a divided-down reference clock of 19.44 MHz. CTRLA[5:2] is set to [0101], that is, 5, because

$$622.08 \text{ Mb/s}/19.44 \text{ MHz} = 2^5$$

In this mode, if the ADN2812 loses lock for any reason, it relocks onto the reference clock and continues to output a stable clock.

While the ADN2812 is operating in LTR mode, if the user ever changes the reference frequency (the FREF range, CTRLA[7:6] or the FREF ratio, CTRLA[5:2]), this must be followed by writing a 1 to 0 transition into the CTRLB[5] bit to initiate a new frequency acquisition.

A frequency acquisition can also be initiated in LTR mode by writing a 0 to 1 transition into CTRLA[0]; however, it is recommended that a frequency acquisition be initiated by writing a 1 to 0 transition into CTRLB[5] as previously explained.

### Using the Reference Clock to Measure Data Frequency

The user can also provide a reference clock to measure the recovered data frequency, in which case the ADN2812 compares the frequency of the incoming data to the incoming reference clock and returns a ratio of the two frequencies to 0.01% (100 ppm). The accuracy error of the reference clock is added to the accuracy of the ADN2812 data rate measurement. For example, if a 100 ppm accuracy reference clock is used, the total accuracy of the measurement is within 200 ppm.

The reference clock can range from 12.3 MHz to 200 MHz. The ADN2812 expects a reference clock between 12.3 MHz and 25 MHz by default. If it is between 25 MHz and 50 MHz, 50 MHz and 100 MHz, or 100 MHz and 200 MHz, the user needs to configure the ADN2812 to use the correct reference frequency range by setting two bits of the CTRLA register, CTRLA[7:6]. Using the reference clock to determine the frequency of the incoming data does not affect the manner in which the part locks onto data. In this mode, the reference clock is used only to determine the frequency of the data. For this reason, the user does not need to know the data rate to use the reference clock in this manner.

Prior to reading back the data rate using the reference clock, Control Register CTRLA Bits[7:6] bits must be set to the appropriate frequency range with respect to the reference clock being used. A fine data rate readback is then executed as follows:

1. Write a 1 to CTRLA[1]. This enables the fine data rate measurement capability of the ADN2812. This bit is level-sensitive and does not need to be reset to perform subsequent frequency measurements.
2. Reset MISC[2] by writing a 1 followed by a 0 to CTRLB[3]. This initiates a new data rate measurement.
3. Read back MISC[2]. If it is 0, the measurement is not complete. If it is 1, the measurement is complete and the data rate can be read back on  $FREQ[22:0]$ . The time for a data rate measurement is typically 80 ms.
4. Read back the data rate from Register  $FREQ2[6:0]$ , Register  $FREQ1[7:0]$ , and Register  $FREQ0[7:0]$ .

Use the following equation to determine the data rate:

$$f_{\text{DATARATE}} = (FREQ[22:0] \times f_{\text{REFCLK}}) / 2^{(14 + SEL\_RATE)}$$

where:

$FREQ[22:0]$  is the reading from  $FREQ2[6:0]$  (MSByte),

$FREQ1[7:0]$ , and  $FREQ0[7:0]$  (LSByte).

$f_{\text{DATARATE}}$  is the data rate (Mb/s).

$f_{\text{REFCLK}}$  is the REFCLK frequency (MHz).

$SEL\_RATE$  is the setting from CTRLA[7:6].

**Table 13.**

D22	D21...D17	D16	D15	D14...D9	D8	D7	D6...D1	D0
FREQ2[6:0]		FREQ1[7:0]			FREQ0[7:0]			

For example, if the reference clock frequency is 32 MHz,  $SEL\_RATE = 1$ , because the CTRLA[7:6] setting is [01] and the reference frequency falls into the 25 MHz to 50 MHz range. Assume for this example that the input data rate is 2.488 Gb/s

(OC-48). After following Step 1 through Step 4, the value that is read back on  $FREQ[22:0] = 0x26E010$ , which is equal to  $2.5477 \times 10^6$ . Plugging this value into the equation yields

$$(2.5477e6 \times 32e6) / (2^{(14+1)}) = 2.488 \text{ Gb/s}$$

If subsequent frequency measurements are required, CTRLA[1] should remain set to 1. It does not need to be reset. The measurement process is reset by writing a 1 followed by a 0 to CTRLB[3]. This initiates a new data rate measurement. Follow Step 2 through Step 4 to read back the new data rate.

Note that a data rate readback is valid only if LOL is low. If LOL is high, the data rate readback is invalid.

### **Additional Features Available via the I<sup>2</sup>C Interface Coarse Data Rate Readback**

The data rate can be read back over the I<sup>2</sup>C interface to approximately  $\pm 10\%$  without the need of an external reference clock. A 9-bit register, COARSE\_RD[8:0], can be read back when LOL is deasserted. The 8 MSBs of this register are the contents of the RATE[7:0] register. The LSB of the COARSE\_RD register is Bit MISC[0]. Table 14 provides coarse data rate readback to within  $\pm 10\%$ .

### **LOS Configuration**

The LOS detector output, LOS (Pin 22), can be configured to be either active high or active low. If CTRLC[2] is set to Logic 0 (default), the LOS pin is active high when a loss of signal condition is detected. Writing a 1 to CTRLC[2] configures the LOS pin to be active low when a loss of signal condition is detected.

### **System Reset**

A frequency acquisition can be initiated by writing a 1 followed by a 0 to the I<sup>2</sup>C Register Bit CTRLB[5]. This initiates a new frequency acquisition while keeping the ADN2812 in the operating mode that it was previously programmed to in Register CTRL[A], Register CTRL[B], and Register CTRL[C].

# APPLICATIONS INFORMATION

## PCB DESIGN GUIDELINES

Proper RF PCB design techniques must be used for optimal performance.

### Power Supply Connections and Ground Planes

Use of one low impedance ground plane is recommended. The VEE pins should be soldered directly to the ground plane to reduce series inductance. If the ground plane is an internal plane and connections to the ground plane are made through vias, multiple vias can be used in parallel to reduce the series inductance, especially on Pin 23, which is the ground return for the output buffers. The exposed pad should be connected to the GND plane using plugged vias so that solder does not leak through the vias during reflow.

Use of a 10  $\mu\text{F}$  electrolytic capacitor between VCC and VEE is recommended at the location where the 3.3 V supply enters the PCB. When using 0.1  $\mu\text{F}$  and 1 nF ceramic chip capacitors, they should be placed between the IC power supply VCC and VEE and as close as possible to the ADN2812 VCC pins.

If connections to the supply and ground are made through vias, the use of multiple vias in parallel helps to reduce series inductance, especially on Pin 24, which supplies power to the high speed CLKOUTP/CLKOUTN and DATAOUTP/DATAOUTN output buffers. Refer to the schematic in Figure 24 for recommended connections.

By using adjacent power supply and GND planes, excellent high frequency decoupling can be realized by using close spacing between the planes. This capacitance is given by

$$C_{plane} = 0.88\epsilon_r A/d \text{ (pF)}$$

where:

$\epsilon_r$  is the dielectric constant of the PCB material.

A is the area of the overlap of power and GND planes ( $\text{cm}^2$ ).

d is the separation between planes (mm).

For FR-4,  $\epsilon_r = 4.4$  and 0.25 mm spacing,  $C \sim 15 \text{ pF/cm}^2$ .

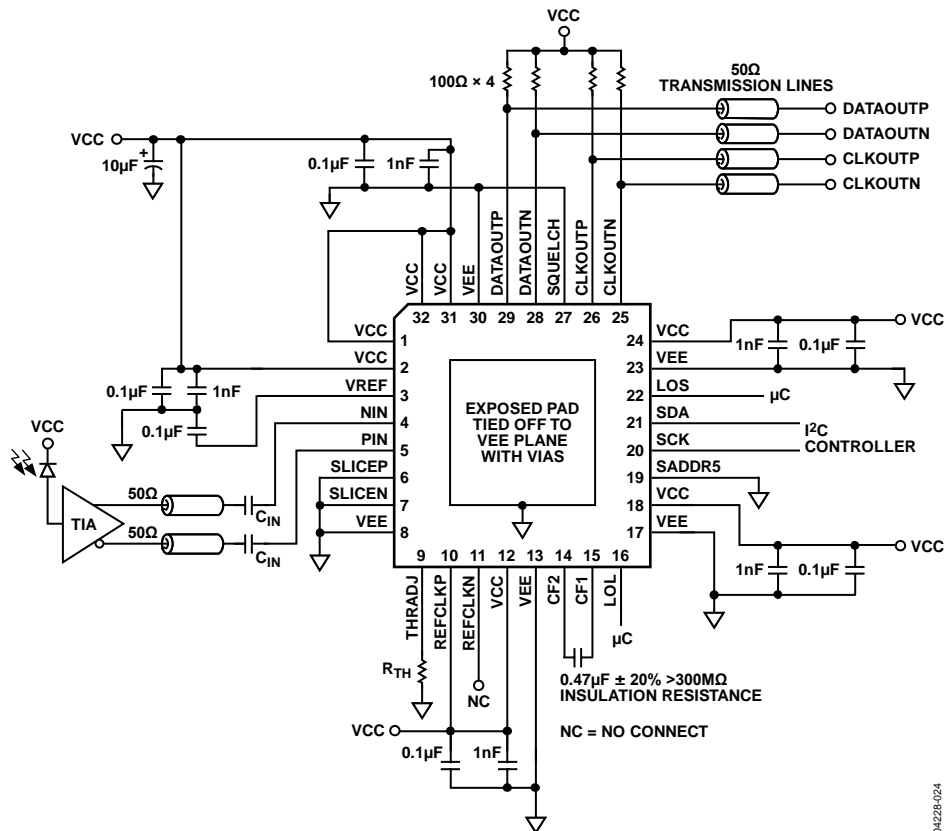

Figure 24. Typical Applications Circuit

04228-024

**Transmission Lines**

Use of 50 Ω transmission lines is required for all high frequency input and output signals to minimize reflections: PIN, NIN, CLKOUTP, CLKOUTN, DATAOUTP, DATAOUTN (also REFCLKP, REFCLKN, if a high frequency reference clock is used, such as 155 MHz). It is also necessary for the PIN/NIN input traces to be matched in length and the CLKOUTP/CLKOUTN and DATAOUTP/DATAOUTN output traces to be matched in length to avoid skew between the differential traces. All high speed CML outputs, CLKOUTP/CLKOUTN and DATAOUTP/DATAOUTN, also require 100 Ω back termination chip resistors connected between the output pin and VCC. These resistors should be placed as close as possible to the output pins. These 100 Ω resistors are in parallel with on-chip 100 Ω termination resistors to create a 50 Ω back termination (see Figure 25).

The high speed inputs, PIN and NIN, are internally terminated with 50 Ω to an internal reference voltage (see Figure 26). A 0.1 μF is recommended between VREF (Pin 3) and GND to provide an ac ground for the inputs.

As with any high speed mixed-signal design, take care to keep all high speed digital traces away from sensitive analog nodes.

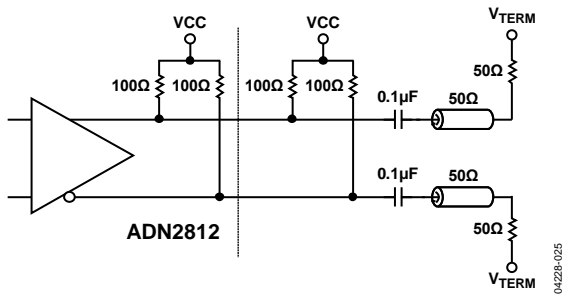

Figure 25. Typical ADN2812 Applications Circuit

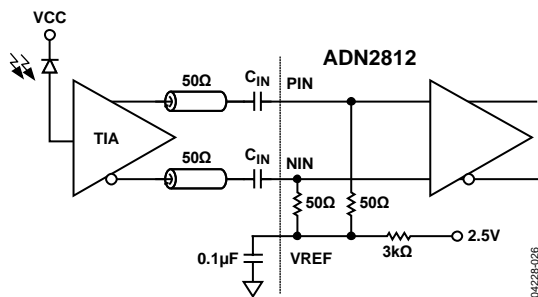

Figure 26. ADN2812 AC-Coupled Input Configuration

**Soldering Guidelines for Chip Scale Package**

The leads on the 32-lead LFCSP are rectangular. The printed circuit board pad for these should be 0.1 mm longer than the package lead length and 0.05 mm wider than the package lead width. The lead should be centered on the pad. This ensures

that the solder joint size is maximized. The bottom of the chip scale package has a central exposed pad. The pad on the printed circuit board should be at least as large as this exposed pad. The user must connect the exposed pad to VEE using plugged vias so that solder does not leak through the vias during reflow. This ensures a solid connection from the exposed pad to VEE.

**Choosing AC Coupling Capacitors**

AC coupling capacitors at the inputs (PIN, NIN) and outputs (DATAOUTP, DATAOUTN) of the ADN2812 must be chosen such that the device works properly over the full range of data rates used in the application. When choosing the capacitors, the time constant formed with the two 50 Ω resistors in the signal path must be considered. When a large number of consecutive identical digits (CIDs) are applied, the capacitor voltage can droop due to baseline wander (see Figure 27), causing pattern-dependent jitter (PDJ).

The user must determine how much droop is tolerable and choose an ac coupling capacitor based on that amount of droop. The amount of PDJ can then be approximated based on the capacitor selection. The actual capacitor value selection may require some trade-offs between droop and PDJ.

For example, assuming that 2% droop can be tolerated, then the maximum differential droop is 4%. Normalizing to  $V_{pp}$

$$Droop = \Delta V = 0.04 V = 0.5 V_{pp} (1 - e^{-t/\tau}); \text{ therefore, } \tau = 12t$$

where:

$\tau$  is the RC time constant (C is the ac coupling capacitor, R = 100 Ω seen by C).

t is the total discharge time, which is equal to nT.

n is the number of CIDs.

T is the bit period.

The capacitor value can then be calculated by combining the equations for  $\tau$  and t

$$C = 12nT/R$$

Once the capacitor value is selected, the PDJ can be approximated as

$$PDJ_{pspp} = 0.5t_r (1 - e^{(-nT/RC)}) / 0.6$$

where:

$PDJ_{pspp}$  is the amount of pattern-dependent jitter allowed; < 0.01 UI p-p typical.

$t_r$  is the rise time, which is equal to 0.22/BW, where BW is ~ 0.7 (bit rate). This expression for  $t_r$  is accurate only for the inputs.

The output rise time for the ADN2812 is ~100 ps regardless of data rate.

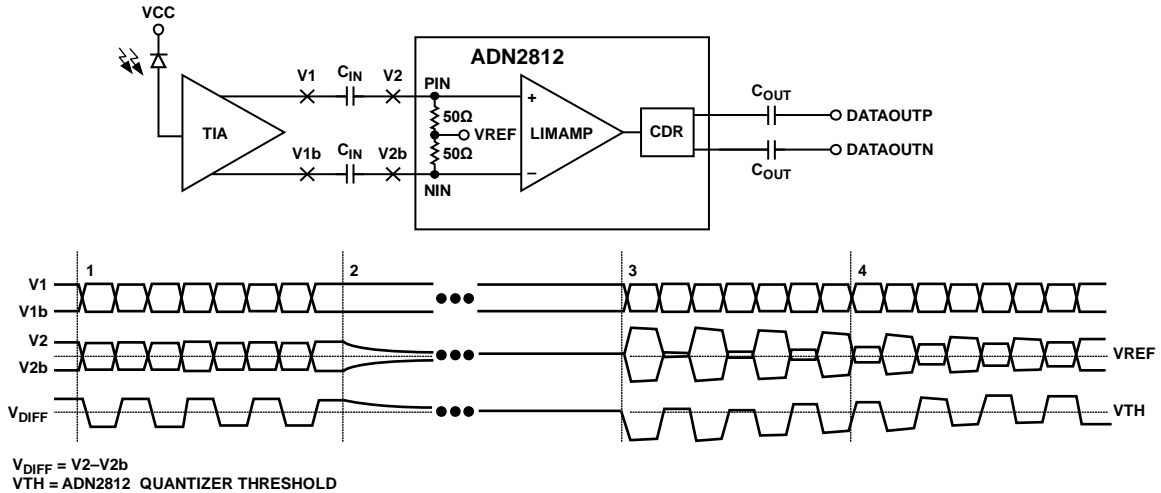

- NOTES:
1. DURING DATA PATTERNS WITH HIGH TRANSITION DENSITY, DIFFERENTIAL DC VOLTAGE AT V1 AND V2 IS ZERO.
  2. WHEN THE OUTPUT OF THE TIA GOES TO CID, V1 AND V1b ARE DRIVEN TO DIFFERENT DC LEVELS. V2 AND V2b DISCHARGE TO THE VREF LEVEL, WHICH EFFECTIVELY INTRODUCES A DIFFERENTIAL DC OFFSET ACROSS THE AC COUPLING CAPACITORS.
  3. WHEN THE BURST OF DATA STARTS AGAIN, THE DIFFERENTIAL DC OFFSET ACROSS THE AC COUPLING CAPACITORS IS APPLIED TO THE INPUT LEVELS CAUSING A DC SHIFT IN THE DIFFERENTIAL INPUT. THIS SHIFT IS LARGE ENOUGH SUCH THAT ONE OF THE STATES, EITHER HIGH OR LOW DEPENDING ON THE LEVELS OF V1 AND V1b WHEN THE TIA WENT TO CID, IS CANCELED OUT. THE QUANTIZER DOES NOT RECOGNIZE THIS AS A VALID STATE.
  4. THE DC OFFSET SLOWLY DISCHARGES UNTIL THE DIFFERENTIAL INPUT VOLTAGE EXCEEDS THE SENSITIVITY OF THE ADN2812. THE QUANTIZER CAN RECOGNIZE BOTH HIGH AND LOW STATES AT THIS POINT.

Figure 27. Example of Baseline Wander

**DC-COUPLED APPLICATION**

The inputs to the ADN2812 can be dc-coupled. This might be necessary in burst mode applications, where there are long periods of CIDs, and baseline wander cannot be tolerated. If the inputs to the ADN2812 are dc-coupled, care must be taken not to violate the input range and common-mode level requirements of the ADN2812 (see Figure 28 through Figure 30). If dc coupling is required, and the output levels of the TIA do not adhere to the levels shown in Figure 29, level shifting and/or an attenuator must be between the TIA outputs and the ADN2812 inputs.

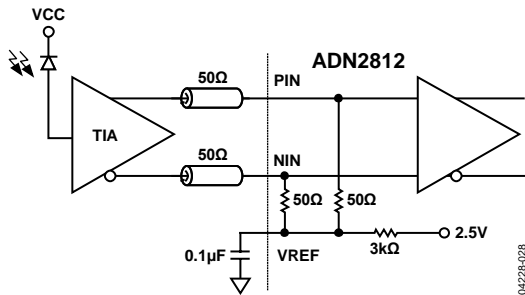

Figure 28. DC-Coupled Application

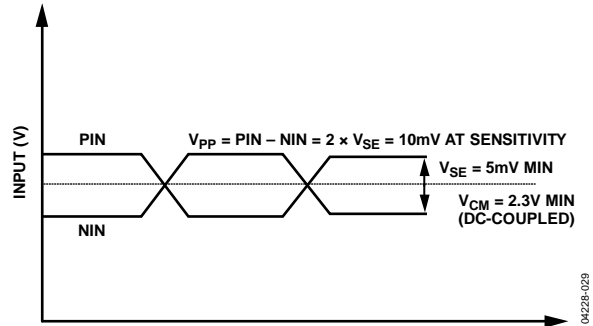

Figure 29. Minimum Allowed DC-Coupled Input Levels

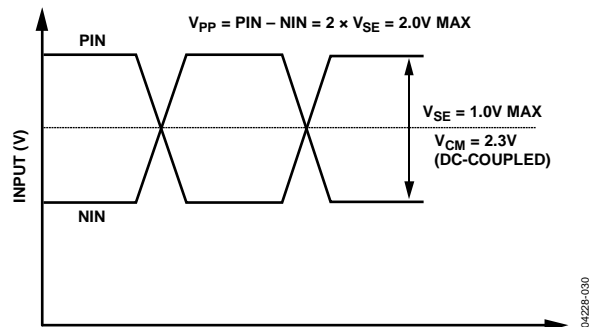

Figure 30. Maximum Allowed DC-Coupled Input Levels

## COARSE DATA RATE READBACK LOOK-UP TABLE

Code is the 9-bit value read back from COARSE\_RD[8:0].

Table 14.

Code	F <sub>MID</sub>	Code	F <sub>MID</sub>	Code	F <sub>MID</sub>	Code	F <sub>MID</sub>
0	5.1934e+06	48	1.4828e+07	96	4.1547e+07	144	1.1862e+08
1	5.1930e+06	49	1.4827e+07	97	4.1544e+07	145	1.1862e+08
2	5.2930e+06	50	1.5121e+07	98	4.2344e+07	146	1.2097e+08
3	5.3989e+06	51	1.5435e+07	99	4.3191e+07	147	1.2348e+08
4	5.5124e+06	52	1.5770e+07	100	4.4099e+07	148	1.2616e+08
5	5.6325e+06	53	1.6127e+07	101	4.5060e+07	149	1.2901e+08
6	5.7612e+06	54	1.6510e+07	102	4.6090e+07	150	1.3208e+08
7	5.8995e+06	55	1.6917e+07	103	4.7196e+07	151	1.3534e+08
8	6.0473e+06	56	1.7357e+07	104	4.8378e+07	152	1.3885e+08
9	6.2097e+06	57	1.7836e+07	105	4.9678e+07	153	1.4269e+08
10	6.3819e+06	58	1.8347e+07	106	5.1055e+07	154	1.4678e+08
11	6.5675e+06	59	1.8896e+07	107	5.2540e+07	155	1.5117e+08
12	6.7688e+06	60	1.9493e+07	108	5.4150e+07	156	1.5594e+08
13	6.9874e+06	61	2.0136e+07	109	5.5899e+07	157	1.6109e+08
14	7.2262e+06	62	2.0833e+07	110	5.7810e+07	158	1.6667e+08
15	7.4863e+06	63	2.1582e+07	111	5.9890e+07	159	1.7266e+08
16	7.7413e+06	64	2.2477e+07	112	6.2611e+07	160	1.7919e+08
17	8.0013e+06	65	2.3477e+07	113	6.5908e+07	161	1.8617e+08
18	8.2666e+06	66	2.4572e+07	114	7.0085e+07	162	1.9338e+08
19	8.5373e+06	67	2.5766e+07	115	7.4939e+07	163	2.0177e+08
20	8.8135e+06	68	2.7049e+07	116	8.0381e+07	164	2.1140e+08
21	9.0953e+06	69	2.8430e+07	117	8.6406e+07	165	2.2244e+08
22	9.3828e+06	70	2.9915e+07	118	9.3038e+07	166	2.3436e+08
23	9.6761e+06	71	3.1508e+07	119	1.0039e+08	167	2.4738e+08
24	9.9753e+06	72	3.3219e+07	120	1.0877e+08	168	2.6151e+08
25	1.0280e+07	73	3.5049e+07	121	1.1844e+08	169	2.7671e+08
26	1.0593e+07	74	3.6997e+07	122	1.2938e+08	170	2.9322e+08
27	1.0913e+07	75	3.9060e+07	123	1.4155e+08	171	3.1116e+08
28	1.1240e+07	76	4.1335e+07	124	1.5491e+08	172	3.3060e+08
29	1.1574e+07	77	4.3820e+07	125	1.6946e+08	173	3.5160e+08
30	1.1915e+07	78	4.6515e+07	126	1.8533e+08	174	3.7424e+08
31	1.2263e+07	79	4.9425e+07	127	2.0262e+08	175	3.9856e+08
32	1.2618e+07	80	5.2655e+07	128	2.2139e+08	176	4.2424e+08
33	1.2980e+07	81	5.6204e+07	129	2.4177e+08	177	4.5123e+08
34	1.3349e+07	82	6.0072e+07	130	2.6389e+08	178	4.7944e+08
35	1.3725e+07	83	6.4269e+07	131	2.8783e+08	179	5.0955e+08
36	1.4108e+07	84	6.8804e+07	132	3.1369e+08	180	5.4133e+08
37	1.4498e+07	85	7.3683e+07	133	3.4150e+08	181	5.7482e+08
38	1.4895e+07	86	7.8919e+07	134	3.7139e+08	182	6.1015e+08
39	1.5299e+07	87	8.4524e+07	135	4.0392e+08	183	6.4737e+08
40	1.5710e+07	88	9.0504e+07	136	4.4937e+08	184	6.8671e+08
41	1.6128e+07	89	9.6862e+07	137	5.0006e+08	185	7.2838e+08
42	1.6553e+07	90	1.0369e+08	138	5.5661e+08	186	7.7255e+08
43	1.6985e+07	91	1.1112e+08	139	6.1950e+08	187	8.1934e+08
44	1.7425e+07	92	1.1915e+08	140	6.8903e+08	188	8.688e+08
45	1.7873e+07	93	1.2783e+08	141	7.6561e+08	189	9.2098e+08
46	1.8329e+07	94	1.3716e+08	142	8.4962e+08	190	9.7593e+08
47	1.8793e+07	95	1.4716e+08	143	9.4137e+08	191	1.0338e+09

Code	F <sub>MID</sub>	Code	F <sub>MID</sub>	Code	F <sub>MID</sub>	Code	F <sub>MID</sub>
192	3.3238e+08	216	5.5542e+08	240	9.4898e+08	264	1.5481e+09
193	3.3235e+08	217	5.7075e+08	241	9.4893e+08	265	1.5897e+09
194	3.3876e+08	218	5.8711e+08	242	9.6776e+08	266	1.6338e+09
195	3.4553e+08	219	6.0468e+08	243	9.8782e+08	267	1.6813e+09
196	3.5279e+08	220	6.2377e+08	244	1.0093e+09	268	1.7328e+09
197	3.6048e+08	221	6.4437e+08	245	1.0321e+09	269	1.7888e+09
198	3.6872e+08	222	6.6666e+08	246	1.0566e+09	270	1.8499e+09
199	3.7757e+08	223	6.9062e+08	247	1.0827e+09	271	1.9165e+09
200	3.8703e+08	224	6.6476e+08	248	1.1108e+09	272	1.8980e+09
201	3.9742e+08	225	6.6470e+08	249	1.1415e+09	273	1.8979e+09
202	4.0844e+08	226	6.7751e+08	250	1.1742e+09	274	1.9355e+09
203	4.2032e+08	227	6.9106e+08	251	1.2094e+09	275	1.9756e+09
204	4.3320e+08	228	7.0558e+08	252	1.2475e+09	276	2.0186e+09
205	4.4719e+08	229	7.2096e+08	253	1.2887e+09	277	2.0642e+09
206	4.6248e+08	230	7.3743e+08	254	1.3333e+09	278	2.1132e+09
207	4.7912e+08	231	7.5514e+08	255	1.3812e+09	279	2.1654e+09
208	4.7449e+08	232	7.7405e+08	256	1.3295e+09	280	2.2217e+09
209	4.7447e+08	233	7.9485e+08	257	1.3294e+09	281	2.2830e+09
210	4.8388e+08	234	8.1688e+08	258	1.3550e+09	282	2.3484e+09
211	4.9391e+08	235	8.4064e+08	259	1.3821e+09	283	2.4187e+09
212	5.0465e+08	236	8.6640e+08	260	1.4112e+09	284	2.4951e+09
213	5.1605e+08	237	8.9438e+08	261	1.4419e+09	285	2.5775e+09
214	5.2831e+08	238	9.2496e+08	262	1.4749e+09	286	2.6666e+09
215	5.4135e+08	239	9.5825e+08	263	1.5103e+09	287	2.7625e+09



OUTLINE DIMENSIONS

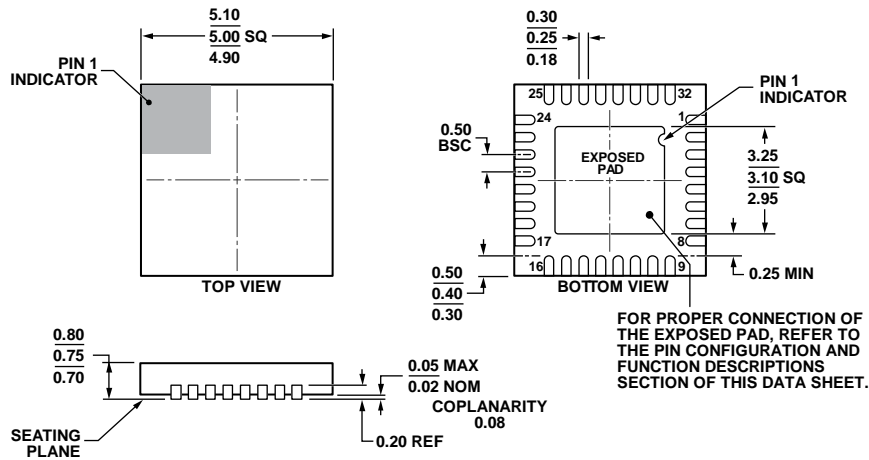

COMPLIANT TO JEDEC STANDARDS MO-220-WHHD.  
 Figure 31. 32-Lead Lead Frame Chip Scale Package [LFCSP\_WQ]  
 5 mm x 5 mm Body, Very Thin Quad  
 (CP-32-7)  
 Dimensions shown in millimeters

112408-A

ORDERING GUIDE

Model <sup>1</sup>	Temperature Range	Package Description	Package Option
ADN2812ACPZ	-40°C to +85°C	32-Lead LFCSP_WQ	CP-32-7
ADN2812ACPZ-RL	-40°C to +85°C	32-Lead LFCSP_WQ, 13" Tape-Reel, 5000 pcs	CP-32-7
ADN2812ACPZ-RL7	-40°C to +85°C	32-Lead LFCSP_WQ, 7" Tape-Reel, 1500 pcs	CP-32-7
EVAL-ADN2812EBZ		Evaluation Board	

<sup>1</sup> Z = RoHS Compliant Part.

**NOTES**

**NOTES**

I<sup>2</sup>C refers to a communications protocol originally developed by Philips Semiconductors (now NXP Semiconductors).

# Mouser Electronics

Authorized Distributor

Click to View Pricing, Inventory, Delivery & Lifecycle Information:

[Analog Devices Inc.:](#)

[ADN2812ACPZ](#) [ADN2812ACPZ-RL](#) [ADN2812ACPZ-RL7](#)