

Fault-Protected, Low-Voltage, Quad SPST Analog Switches

ABSOLUTE MAXIMUM RATINGS

V+	-0.3V to +13V
V-	-13V to +0.3V
V+ to V-	-0.3V to +13V
IN	(V- + 12V) to (V- - 0.3V)
COM ₋ (Note 1)	(V- - 0.3V) to (V+ + 0.3V)
NO ₋ , NC ₋ (Note 2)	(V+ - 12V) to (V- + 12V)
Continuous Current into Any Terminal	±40mA
Peak Current, into Any Terminal (pulsed at 1ms, 10% duty cycle)	±70mA

Continuous Power Dissipation (T _A = +70°C)	
16-Pin TSSOP (derate 5.70mW/°C above +70°C)	457mW
16-Pin Narrow SO (derate 8.70mW/°C above +70°C)	696mW
16-Pin Plastic Dip (derate 10.53mW/°C above +70°C)	842mW
Operating Temperature Ranges	
MAX471_C_E	0°C to +70°C
MAX471_E_E	-40°C to +85°C
Junction Temperature	+150°C
Storage Temperature Range	-65°C to +150°C
Lead Temperature (soldering, 10s)	+300°C

Note 1: COM₋ pin is not fault-protected. Signals on COM₋ exceeding V+ or V- are clamped by internal diodes. Limit forward diode current to maximum current rating.

Note 2: NO₋ and NC₋ pins are fault-protected. Signals on NO₋ or NC₋ exceeding -12V to +12V may damage device. These limits apply with V+ = V- = 0.

Stresses beyond those listed under "Absolute Maximum Ratings" may cause permanent damage to the device. These are stress ratings only, and functional operation of the device at these or any other conditions beyond those indicated in the operational sections of the specifications is not implied. Exposure to absolute maximum rating conditions for extended periods may affect device reliability.

ELECTRICAL CHARACTERISTICS—Dual Supplies

(V+ = +4.5V to +5.5V, V- = -4.5V to -5.5V, V_{IH} = +2.4V, V_{IL} = +0.8V, GND = 0, T_A = T_{MIN} to T_{MAX}, unless otherwise noted. Typical values are at T_A = +25°C.) (Note 3)

PARAMETER	SYMBOL	CONDITIONS	T _A	MIN	TYP	MAX	UNITS
ANALOG SWITCH							
Fault-Free Analog Signal Range	V _{COM-} , V _{NO-} , V _{NC-}	Applies with power on	C, E	V-		V+	V
On-Resistance	R _{ON}	V+ = +4.5V, V- = -4.5V, V _{NO-} , V _{NC-} = ±3.5V, I _{OUT} = 10mA	+25°C C, E		16 25	30	Ω
On-Resistance Match Between Channels (Note 4)	ΔR _{ON}	V+ = +4.5V, V- = -4.5V, V _{NO-} , V _{NC-} = ±3.5V, I _{OUT} = 10mA	+25°C C, E		0.2 1	2	Ω
On-Resistance Flatness	R _{FLAT}	V+ = +4.5V, V- = -4.5V, V _{NO-} , V _{NC-} = ±3.5V, I _{OUT} = 10mA	+25°C C, E		1.3 4	5	Ω
NO ₋ , NC ₋ Off-Leakage Current (Note 5)	I _{NO-(OFF)} , I _{NC-(OFF)}	V+ = +5.5V, V- = -5.5V, V _{COM-} = ±4.5V, V _{NO-} , V _{NC-} = 4.5V	+25°C C, E	-0.5 -10		+0.5 +10	nA
COM ₋ Off-Leakage Current (Note 5)	I _{COM-(OFF)}	V+ = +5.5V, V- = -5.5V, V _{COM-} = ±4.5V, V _{NO-} , V _{NC-} = 4.5V	+25°C C, E	-0.5 -10		+0.5 +10	nA
COM ₋ On-Leakage Current (Note 5)	I _{COM-(ON)}	V+ = +5.5V, V- = -5.5V, V _{COM-} = ±4.5V, V _{NO-} , V _{NC-} = ±4.5V or floating	+25°C C, E	-0.5 -20		+0.5 +20	nA
FAULT							
Fault-Protected Analog Signal Range	V _{NO-} , V _{NC-}	Applies with power on	C, E	-12 + V+		+12 + V-	V
Fault-Protected Analog Signal Range	V _{NO-} , V _{NC-}	Applies with power off	C, E	-12		+12	V
COM ₋ Output-Leakage Current, Supplies ON (Note 5)	I _{COM}	All channels off, V+ = +5V, V- = -5V, V _{NO-} , V _{NC-} = ±7V	+25°C C, E	-50 -500		+50 +500	nA

Fault-Protected, Low-Voltage, Quad SPST Analog Switches

MAX4711/MAX4712/MAX4713

ELECTRICAL CHARACTERISTICS—Dual Supplies (continued)

(V+ = +4.5V to +5.5V, V- = -4.5V to -5.5V, V_{IH} = +2.4V, V_{IL} = +0.8V, GND = 0, T_A = T_{MIN} to T_{MAX}, unless otherwise noted. Typical values are at T_A = +25°C.) (Note 3)

PARAMETER	SYMBOL	CONDITIONS	T _A	MIN	TYP	MAX	UNITS	
NO ₋ or NC ₋ Off-Leakage Current, Supplies ON (Note 5)	I _{NO-} , I _{NC-}	V+ = +5V, V- = -5V, V _{NO-} , V _{NC-} = ±7V	+25°C	-50		+50	nA	
			C, E	-500		+500		
NO ₋ or NC ₋ Input-Leakage Current, Supplies OFF (Note 5)	I _{NO-} , I _{NC-}	V _{NO-} , V _{NC-} = ±12V, V± = 0	+25°C	-0.5		+0.5	μA	
			C, E	-5		+5		
Output Clamp Current	I _{COM-}	V _{NO-} , V _{NC-} = +7V, V+ = +5V, V- = -5V	C, E		9	20	33	mA
					-33	-16	-9	
Output Clamp Resistance	R _{CLAMP-}	V _{NO-} , V _{NC-} = ±7V	+25°C		200		Ω	
Fault Trip Threshold			+25°C	V- - 0.4V		V+ + 0.4V	V	
±Fault Output Turn-On Delay Time		V _{NO-} , V _{NC-} = ±7V, R _{COM} = 1kΩ	+25°C		200		ns	
±Fault Recovery Time		V _{NO-} , V _{NC-} = ±7V, R _{COM} = 1kΩ	+25°C		700		ns	
LOGIC INPUT								
Input Logic High	V _{IH}		C, E	2.4			V	
Input Logic Low	V _{IL}		C, E			0.8	V	
Input-Leakage Current (Note 5)	I _{IN}	V _{IN-} = 0 or V+	+25°C	-1		+1	μA	
			C, E	-5		+5		
SWITCH DYNAMICS								
Turn-On Time	t _{ON}	V _{NO-} or V _{NC-} = ±3V, R _L = 300Ω, C _L = 35pF, Figure 2	+25°C		80	125	ns	
			C, E			150		
Turn-Off Time	t _{OFF}	V _{NO-} or V _{NC-} = ±3V, R _L = 300Ω, C _L = 35pF, Figure 2	+25°C		50	80	ns	
			C, E			100		
Break-Before-Make Time Delay (MAX4713 only)	t _{BBM}	V _{NO-} or V _{NC-} = ±3V, R _L = 300Ω, C _L = 35pF, Figure 2	+25°C	15	30		ns	
			C, E	5				
Charge Injection	Q	V _{GEN} = 0, R _{GEN} = 0, C _L = 1nF, Figure 4	+25°C		25		pC	
NO ₋ or NC ₋ Off-Capacitance	C _{N(OFF)}	f = 1MHz, Figure 5	+25°C		8		pF	
COM ₋ Off-Capacitance	C _{COM(OFF)}	f = 1MHz, Figure 5	+25°C		8		pF	
COM ₋ On-Capacitance	C _{COM(ON)}	f = 1MHz, Figure 5	+25°C		30		pF	
Off-Isolation (Note 6)	V _{ISO}	R _L = 50Ω, C _L = 15pF, P _{IN} = 0, f = 1MHz, Figure 6	+25°C		-59		dB	
Channel-to-Channel Crosstalk (Note 7)	V _{CT}	R _L = 50Ω, C _L = 15pF, P _{IN} = 0, f = 1MHz, Figure 6	+25°C		-87		dB	

Fault-Protected, Low-Voltage, Quad SPST Analog Switches

ELECTRICAL CHARACTERISTICS—Dual Supplies (continued)

(V+ = +4.5V to +5.5V, V- = -4.5V to -5.5V, V_{IH} = +2.4V, V_{IL} = +0.8V, GND = 0, T_A = T_{MIN} to T_{MAX}, unless otherwise noted. Typical values are at T_A = +25°C.) (Note 3)

PARAMETER	SYMBOL	CONDITIONS	T _A	MIN	TYP	MAX	UNITS
POWER SUPPLY							
Power-Supply Range	V+, V-		C, E	±2.7		±5.5	V
V+ Supply Current	I+	All V _{IN} = 0 or V+	+25°C		38	75	μA
			C, E			100	
V- Supply Current	I-	All V _{IN} = 0 or V+	+25°C		38	75	μA
			C, E			100	
GND Supply Current	I _{GND}	All V _{IN} = 0 or V+	+25°C		0	1	μA
			C, E			10	

ELECTRICAL CHARACTERISTICS—+5V Single Supply

(V+ = +4.5V to +5.5V, V- = 0, V_{IH} = +2.4V, V_{IL} = +0.8V, GND = 0, T_A = T_{MIN} to T_{MAX}, unless otherwise noted. Typical values are at T_A = +25°C.) (Note 3)

PARAMETER	SYMBOL	CONDITIONS	T _A	MIN	TYP	MAX	UNITS
ANALOG SWITCH							
Fault-Free Analog Signal Range	V _{COM} , V _{NO} , V _{NC}	Power on	C, E	V-		V+	V
On-Resistance	R _{ON}	V+ = +4.5V, V _{NO} , V _{NC} = +3.5V, I _{OUT} = 10mA	+25°C		30	40	Ω
			C, E			50	
On-Resistance Match Between Channels (Note 4)	ΔR _{ON}	V+ = +4.5V, V _{NO} , V _{NC} = +3.5V, I _{OUT} = 10mA	+25°C		0.3	2	Ω
			C, E			3	
On-Resistance Flatness	R _{FLAT}	V+ = +4.5V, V _{NO} , V _{NC} = +1.5V, +2.25V, +3.5V, I _{OUT} = 10mA	+25°C		2	5	Ω
			C, E			6	
NO ₋ , NC ₋ Off-Leakage Current (Note 5)	I _{NO(OFF)} , I _{NC(OFF)}	V+ = +5.5V, V _{COM} = +1V, +4.5V; V _{NO} , V _{NC} = +4.5V, +1V	+25°C		-0.5	+0.5	nA
			C, E			-10	
COM ₋ Off-Leakage Current (Note 5)	I _{COM(OFF)}	V+ = +5.5V, V _{COM} = +1V, +4.5V; V _{NO} , V _{NC} = +4.5V, +1V	+25°C		-0.5	+0.5	nA
			C, E			-10	
COM ₋ On-Leakage Current (Note 5)	I _{COM(ON)}	V+ = +5.5V, V _{COM} = +1V, +4.5V; V _{NO} , V _{NC} = +1V, +4.5V, or floating	+25°C		-0.5	+0.5	nA
			C, E			-20	
FAULT							
Fault-Protected Analog Signal Range	V _{NO} , V _{NC}	Power on	C, E	-12 + V+		+12	V

Fault-Protected, Low-Voltage, Quad SPST Analog Switches

MAX4711/MAX4712/MAX4713

ELECTRICAL CHARACTERISTICS—+5V Single Supply (continued)

(V+ = +4.5V to +5.5V, V- = 0, V_{IH} = +2.4V, V_{IL} = +0.8V, GND = 0, T_A = T_{MIN} to T_{MAX}, unless otherwise noted. Typical values are at T_A = +25°C.) (Note 3)

PARAMETER	SYMBOL	CONDITIONS	T _A	MIN	TYP	MAX	UNITS
Fault-Protected Analog Signal Range	V _{NO-} , V _{VNC-}	Power off	C, E	-12		+12	V
COM_ Output-Leakage Current, Supplies ON (Note 5)	I _{COM-}	All channels off; V _{NO-} , V _{VNC-} = +12V or -7V, V+ = +5V	+25°C C, E	-50 -500		+50 +500	nA
NO_ or NC_ Off-Leakage Current, Supplies ON (Note 5)	I _{NO-} , I _{VNC-}	V _{NO-} , V _{VNC-} = +12V or -7V, V+ = +5V	+25°C C, E	-50 -500		+50 +500	nA
NO_ or NC_ Input-Leakage Current, Supplies OFF (Note 5)	I _{NO-} , I _{VNC-}	V _{NO-} , V _{VNC-} = ±12V, V± = 0	+25°C C, E	-0.5 -5		+0.5 +5	μA
Output Clamp Current	I _{COM-}	V _{NO-} , V _{VNC-} = +12V, V+ = 5V	C, E	2	6	11	mA
Output Clamp Resistance	R _{CLAMP-}	Clamp on	+25°C		500		Ω
+Fault Output Turn-On Delay Time		V _{NO-} , V _{VNC-} = +12V, R _L = 300Ω, V+ = +5V	+25°C		200		ns
+Fault Recovery Time		V _{NO-} , V _{VNC-} = +12V, R _L = 300Ω, V+ = +5V	+25°C		500		μs
LOGIC INPUT							
Input Logic High	V _{IH}		C, E	2.4			V
Input Logic Low	V _{IL}		C, E			0.8	V
Input-Leakage Current (Note 5)	I _{IN}	V _{IN-} = 0 or V+	C, E	-1		+1	μA
SWITCH DYNAMICS							
Turn-On Time	t _{ON}	V _{NO-} or V _{VNC-} = +3V, R _L = 300Ω, C _L = 35pF, Figure 2	+25°C C, E		170 230	230 275	ns
Turn-Off Time	t _{OFF}	V _{NO-} or V _{VNC-} = +3V, R _L = 300Ω, C _L = 35pF, Figure 2	+25°C C, E		55 125	100 125	ns
Break-Before-Make Time Delay (MAX4713 only)	t _{BBM}	V _{NO-} or V _{VNC-} = +3V, R _L = 300Ω, C _L = 35pF, Figure 2	+25°C C, E	30 20	115		ns
Charge Injection	Q	V _{GEN} = 0, R _{GEN} = 0, C _L = 1nF, Figure 4	+25°C		-1		pC
POWER SUPPLY							
Power-Supply Range	V+		C, E	2.7		11	V
V+ Supply Current	I+	All V _{IN-} = 0 or V+	+25°C C, E		34 75	65	μA

Fault-Protected, Low-Voltage, Quad SPST Analog Switches

ELECTRICAL CHARACTERISTICS—+3V Single Supply

($V_+ = +2.7V$ to $+3.6V$, $V_- = 0$, $V_{IH} = +2.0V$, $V_{IL} = +0.6V$, $GND = 0$, $T_A = T_{MIN}$ to T_{MAX} , unless otherwise noted. Typical values are at $T_A = +25^\circ C$.) (Note 3)

PARAMETER	SYMBOL	CONDITIONS	T_A	MIN	TYP	MAX	UNITS
ANALOG SWITCH							
Fault-Free Analog Signal Range	$V_{COM_}$, $V_{NO_}$, $V_{NC_}$	Power-on	C, E	V_-		V_+	V
On-Resistance	R_{ON}	$V_+ = +2.7V$, $V_{NO_}$, $V_{NC_} = +1V$, $I_{OUT} = 1mA$	+25°C C, E		54 75	75 100	Ω
On-Resistance Match Between Channels (Note 4)	ΔR_{ON}	$V_+ = +2.7V$, $V_{NO_}$, $V_{NC_} = +1V$, $I_{OUT} = 1mA$	+25°C C, E		1 7	7 9	Ω
$NO_$, $NC_$ Off-Leakage Current (Note 5)	$I_{NO_}(OFF)$, $I_{NC_}(OFF)$	$V_+ = +3.6V$, $V_{COM_} = +0.7V$, $+3V$; $V_{NO_}$, $V_{NC_} = +3V$, $+0.7V$	+25°C C, E	-0.5 -10		+0.5 +10	nA
$COM_$ Off-Leakage Current (Note 5)	$I_{COM_}(OFF)$	$V_+ = +3.6V$, $V_{COM_} = +0.7V$, $+3V$; $V_{NO_}$, $V_{NC_} = +3V$, $+0.7V$	+25°C C, E	-0.5 -10		+0.5 +10	nA
$COM_$ On-Leakage Current (Note 5)	$I_{COM_}(ON)$	$V_+ = +3.6V$, $V_{COM_} = +0.7$, $+3V$; $V_{NO_}$, $V_{NC_} = +0.7V$, $+3V$, or floating	+25°C C, E	-0.5 -20		+0.5 +20	nA
FAULT							
Fault-Protected Analog Signal Range	$V_{NO_}$, $V_{NC_}$	Power-on	C, E	$-12 + V_+$		+12	V
Fault-Protected Analog Signal Range	$V_{NO_}$, $V_{NC_}$	Power-off	C, E	-12		+12	V
$COM_$ Output-Leakage Current, Supplies ON (Note 5)	I_{COM}	All channels off; $V_{NO_}$, $V_{NC_} = +12V$ or $-9V$, $V_+ = +3V$	+25°C C, E	-50 -500		+50 +500	nA
$NO_$ or $NC_$ Off-Leakage Current, Supplies ON (Note 5)	$I_{NO_}$, $I_{NC_}$	$V_{NO_}$, $V_{NC_} = +12V$ or $-9V$, $V_+ = +3V$	+25°C C, E	-50 -500		+50 +500	nA
$NO_$ or $NC_$ Input-Leakage Current, Supplies OFF (Note 5)	$I_{NO_}$, $I_{NC_}$	$V_{NO_}$, $V_{NC_} = \pm 12V$, $V_{\pm} = 0$	+25°C C, E	-0.5 -5		+0.5 +5	μA
Output Clamp Current	$I_{COM_}$	$V_{NO_}$, $V_{NC_} = +12V$, $V_+ = +3V$	C, E	0.5		3.0	mA
Output Clamp Resistance	$R_{CLAMP_}$	$V_+ = +3V$, $V_{NO_}$, $V_{NC_} = +12V$; clamp on	+25°C		600		k Ω
+Fault Output Turn-On Delay Time		$V_{NO_}$, $V_{NC_} = +12V$, $R_L = 300\Omega$, $V_+ = +3V$	+25°C		200		ns
+Fault Recovery Time		$V_{NO_}$, $V_{NC_} = +12V$, $R_L = 300\Omega$, $V_+ = +3V$	+25°C		2.2		μs

Fault-Protected, Low-Voltage, Quad SPST Analog Switches

MAX4711/MAX4712/MAX4713

ELECTRICAL CHARACTERISTICS—+3V Single Supply (continued)

(V+ = +2.7V to +3.6V, V- = 0, V_{IH} = +2.0V, V_{IL} = +0.6V, GND = 0, T_A = T_{MIN} to T_{MAX}, unless otherwise noted. Typical values are at T_A = +25°C.) (Note 3)

PARAMETER	SYMBOL	CONDITIONS	T _A	MIN	TYP	MAX	UNITS
LOGIC INPUT							
Input Logic High	V _{IH}		C, E	2			V
Input Logic Low	V _{IL}		C, E			0.6	V
Input-Leakage Current (Note 5)	I _{INL}	V _{INL} = 0 or V+	C, E	-5		+5	μA
SWITCH DYNAMICS							
Turn-On Time	t _{ON}	V+ = +2.7V, V _{NO-} or V _{NC-} = +1.5V, R _L = 300Ω, C _L = 35pF, Figure 2	+25°C	340	500		ns
			C, E		600		
Turn-Off Time	t _{OFF}	V+ = +2.7V, V _{NO-} or V _{NC-} = +1.5V, R _L = 300Ω, C _L = 35pF, Figure 2	+25°C	100	175		ns
			C, E		225		
Break-Before-Make Time Delay (MAX4713 only)	t _{BBM}	V+ = +2.7V, V _{NO-} or V _{NC-} = +1.5V, R _L = 300Ω, C _L = 35pF, Figure 2	+25°C	60	240		ns
			C, E	50			
POWER SUPPLY							
Power-Supply Range	V+		C, E	2.7		11	V
V+ Supply Current	I+	All V _{INL} = 0 or V+	+25°C	8		15	μA
			C, E			20	

Note 3: Algebraic convention is used in this data sheet; the most negative value is shown in the minimum column.

Note 4: $\Delta R_{ON} = \Delta R_{ON}(MAX) - \Delta R_{ON}(MIN)$

Note 5: Leakage parameters are 100% tested at maximum-rated temperature and with dual supplies. Leakage parameters are guaranteed by correlation at +25°C.

Note 6: Off-isolation = $20 \log_{10} [V_{COM-}/(V_{NO-} \text{ or } V_{NC-})]$, V_{COM-} = output, V_{NO-} or V_{NC-} = input to off switch.

Note 7: Between any two switches.

Fault-Protected, Low-Voltage, Quad SPST Analog Switches

Typical Operating Characteristics

($V_+ = +5V$, $V_- = -5V$, $T_A = +25^\circ C$, unless otherwise noted.)

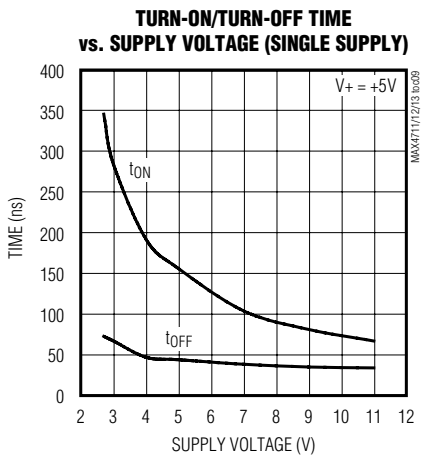
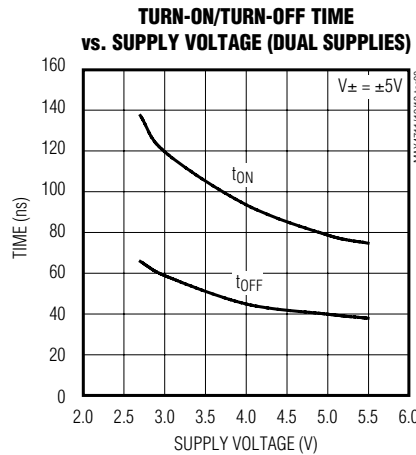
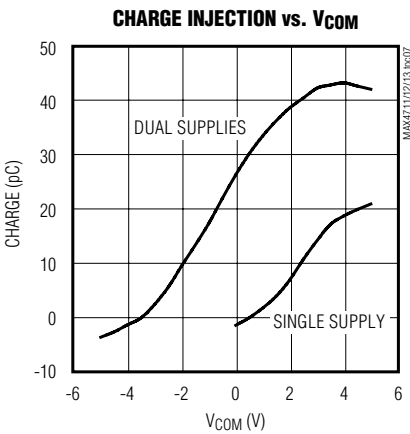
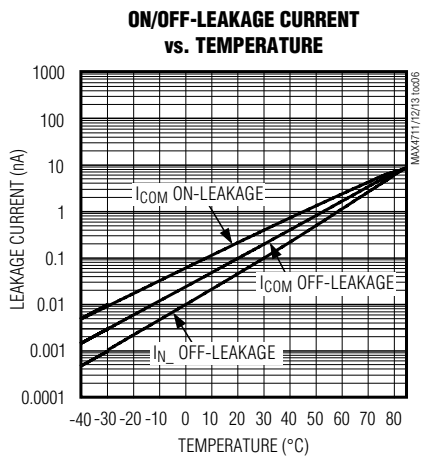
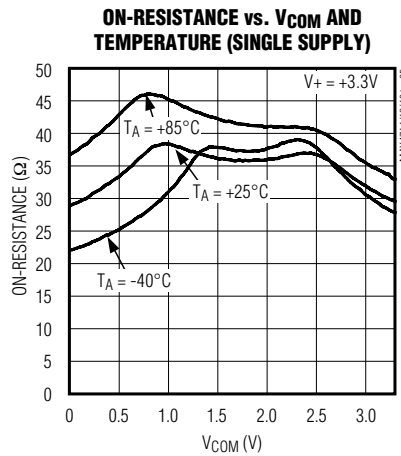
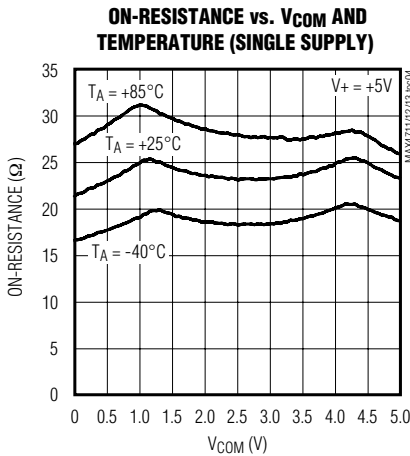
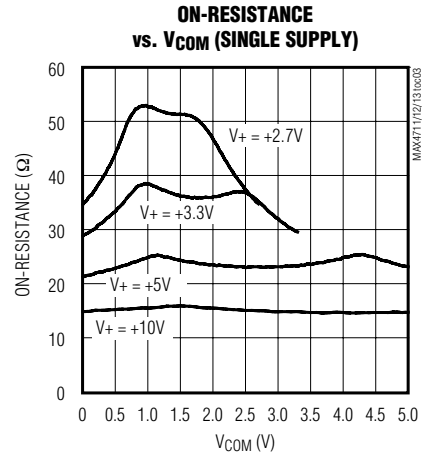
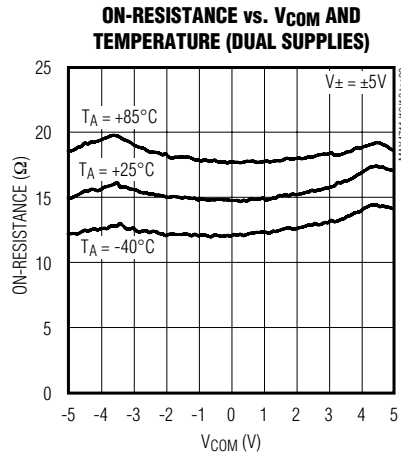
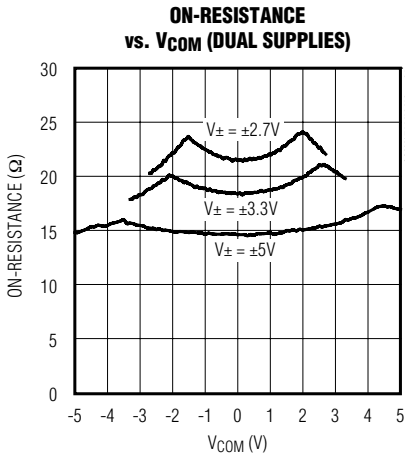

Fault-Protected, Low-Voltage, Quad SPST Analog Switches

Typical Operating Characteristics (continued)

($V_+ = +5V$, $V_- = -5V$, $T_A = +25^\circ C$, unless otherwise noted.)

MAX4711/MAX4712/MAX4713

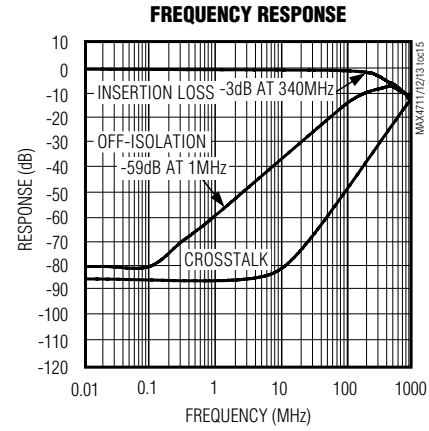
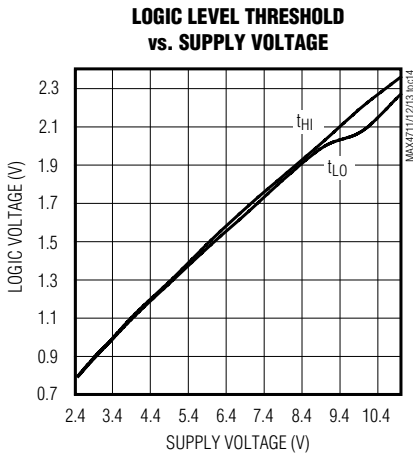
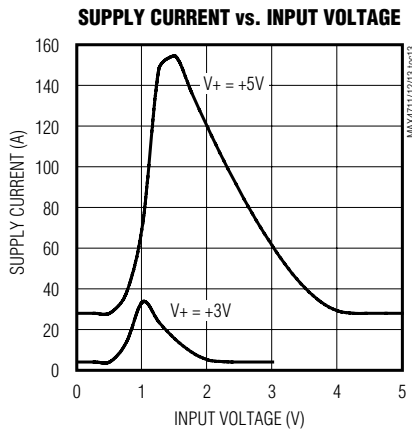
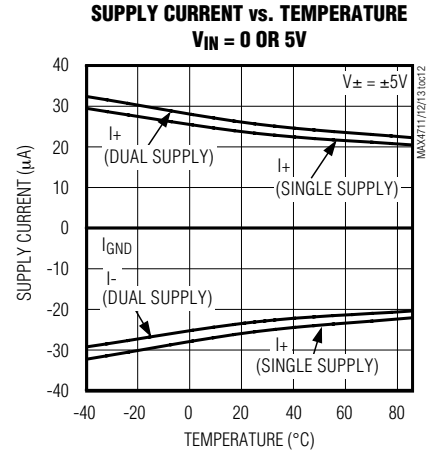
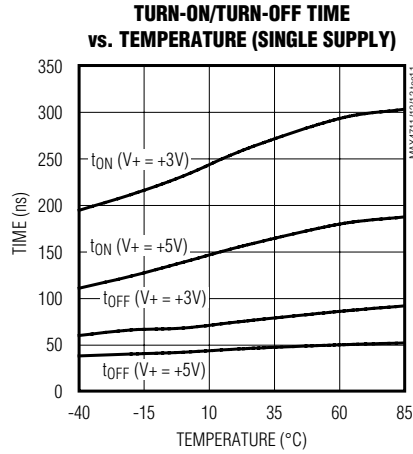
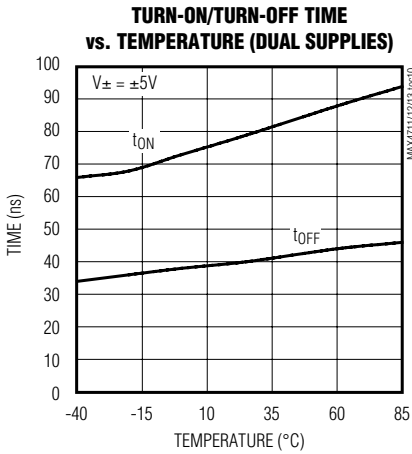

FAULT TURN-ON DELAY AND RECOVERY TIME

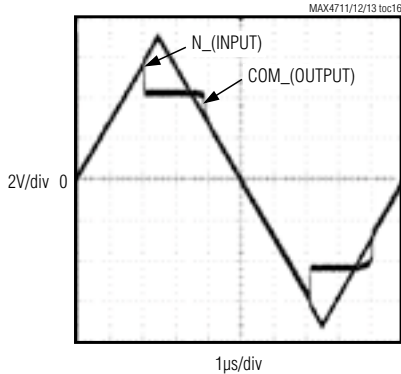

FAULT TURN-ON DELAY AND RECOVERY TIME

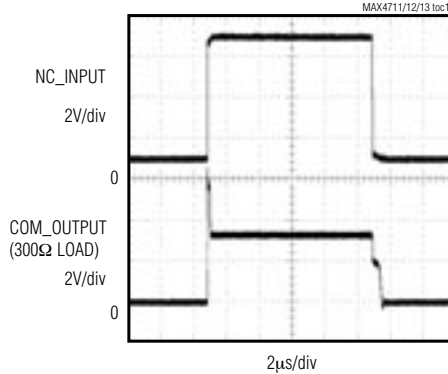

Fault-Protected, Low-Voltage, Quad SPST Analog Switches

Pin Description

PIN			NAME	FUNCTION
MAX4711	MAX4712	MAX4713		
1, 16, 9, 8	1, 16, 9, 8	1, 16, 9, 8	IN1, IN2, IN3, IN4	Logic Inputs. Fault-protected to (V- + 12V).
2, 15, 10, 7	2, 15, 10, 7	2, 15, 10, 7	COM1, COM2, COM3, COM4	Analog Switch Common Terminals
3, 14, 11, 6	—	—	NC1, NC2, NC3, NC4	Fault-Protected Analog Switch Normally Closed Terminals
—	3, 14, 11, 6	—	NO1, NO2, NO3, NO4	Fault-Protected Analog Switch Normally Open Terminals
—	—	3, 6	NO1, NO4	Fault-Protected Analog Switch Normally Open Terminals
—	—	14, 11	NC2, NC3	Fault-Protected Analog Switch Normally Closed Terminals
4	4	4	V-	Negative Supply Voltage Input. Connect to GND for single-supply operation.
5	5	5	GND	Ground
12	12	12	N.C.	No Connection. Not internally connected.
13	13	13	V+	Positive Supply Input

Detailed Description

The MAX4711/MAX4712/MAX4713 differ considerably from traditional fault-protection switches, with several advantages. First, they are constructed with two parallel FET's allowing very low on-resistance. Second, they allow signals on the NC_ or NO_ pins that are within or slightly beyond the supply rails to be passed through the switch to the COM terminal, allowing rail-to-rail signal operation. Third, when a signal on NC_ or NO_ exceeds the supply rails by about 150mV (a fault condition) the voltage on COM_ is limited to the same polarity supply voltage. Operation is identical for both fault polarities.

During a fault condition, the NO_ or NC_ input becomes high impedance regardless of the switch state or load resistance. If the switch is on, the COM_ output current is supplied from V+ or V- by the clamp FET's that are connected from COM to each supply. These FET's can typically source or sink up to 15mA. When power is removed, the fault protection is still in effect. In this case, the NO_ or NC_ terminals are a virtual open circuit. The fault can be up to $\pm 12V$.

The COM_ pins are not fault-protected, they act as normal CMOS switch terminals. If a voltage source is connected to any COM_ pin, it should be limited to the supply voltages. Exceeding the supply voltage will

cause high currents to flow through the ESD-protected diodes, possibly damaging the device (see *Absolute Maximum Ratings*).

Pin Compatibility

These switches have identical pinouts to common non-fault-protected CMOS switches. Care should be exercised while considering them for direct replacements in existing printed circuit boards since only the NO_ and NC_ pins of each switch are fault-protected.

Internal Construction

Internal construction is shown in Figure 1, with the analog signal paths shown in bold. A single NO switch is shown; the NC configuration is identical except the logic-level translator is inverting. The analog switch is formed by the parallel combination of N-channel FET (N1) and P-channel FET (P1), which are driven on and off simultaneously according to the input fault condition and the logic-level state.

Normal Operation

Two comparators continuously compare the voltage on the NO_ (or NC_) pin with V+ and V-. When the signal on NO_ or NC_ is between V+ and V- the switch acts normally, with FETs N1 and P1 turning on and off in response to IN_ signals. The parallel combination of N1 and P1 forms a low-value resistor between NO_ (or

Fault-Protected, Low-Voltage, Quad SPST Analog Switches

MAX4711/MAX4712/MAX4713

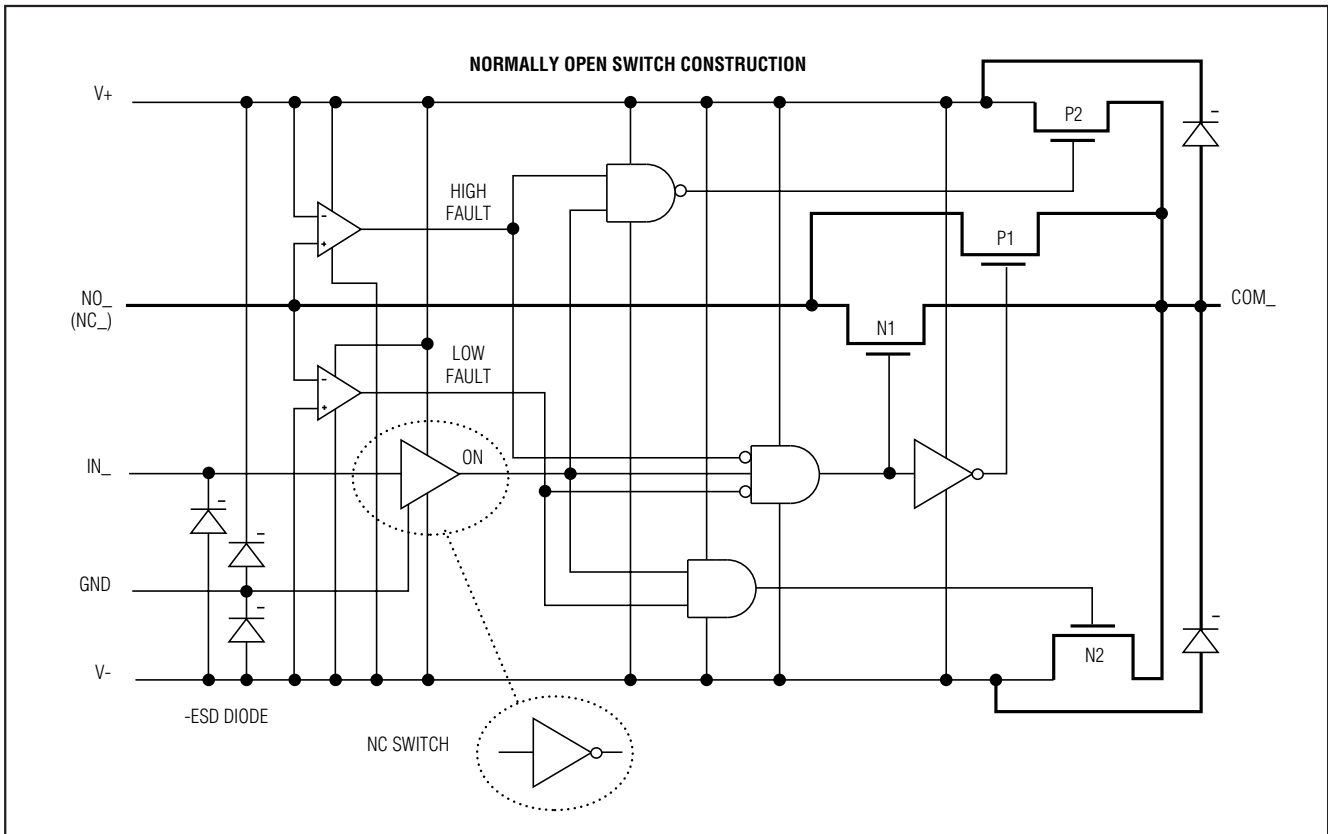

Figure 1. Block Diagram

NC_) and COM_ so that signals pass equally well in either direction.

Positive Fault Condition

When the signal on NO_ (or NC_) exceeds V+ by about 150mV, the high-fault comparator output is high, turning off FETs N1 and P1. This makes the NO_ (or NC_) input high impedance regardless of the switch state. If the switch state is "off", all FETs are turned off and both NO_ (or NC_) and COM_ are high impedance. If the switch state is "on", clamp FET P2 is turned on, sourcing current from V+ to COM_.

Negative Fault Condition

When the signal on NO_ (or NC_) exceeds V- by about 150mV, the low-fault comparator output is high, turning off FETs N1 and P1. This makes the NO_ (or NC_) input high impedance regardless of the switch state. If the switch state is "off", all FETs are turned off and both NO_ (or NC_) and COM_ are high impedance. If the switch state is "on", clamp FET N2 is turned on, sinking current from COM_ to V-.

Transient Fault Response and Recovery

When a fast rise-time or fall-time transient on NC_ or NO_ exceeds V+ or V-, the output (COM_) follows the input to the supply rail with only a few nanoseconds delay. This delay is due to the switch on-resistance and circuit capacitance to ground. When the input transient returns to within the supply rails, however, there is a 700ns output recovery delay time. These values depend on the COM_ output resistance and capacitance, and are not production tested or guaranteed. The delays are not dependent on the fault amplitude. Higher COM_ output resistance and capacitance increase recovery times.

COM_ and IN_ Pins

FETs N2 and P2 can source about $\pm 15\text{mA}$ from V+ or V- to COM_ in the fault condition. Ensure that if the COM_ pin is connected to a low-resistance load, the absolute maximum current rating of 40mA is never exceeded both in normal and fault conditions.

Fault-Protected, Low-Voltage, Quad SPST Analog Switches

The COM_ pins do not have fault protection. Reverse ESD-protection diodes are internally connected between COM_ and V+ and V-. If a signal on COM_ exceeds V+ or V- by more than a diode drop, one of these diodes will conduct. The IN_ pin can exceed the positive supply voltage, but they can go below the negative supply by only a diode drop. The maximum voltage on these pins is 12V if operating from a single supply, regardless of the supply voltage (including 0 volts), and if operating from dual supplies, the maximum voltage is (V- + 12V).

Fault-Protection Voltage and Power Off

The maximum fault voltage on the NC_ or NO_ pins is ±12V with power off.

IN_ Logic-Level Thresholds

The logic-level thresholds are CMOS and TTL compatible when using ±4.5V to ±5.5V or single +4.5V to +11V supplies. When using a +2.7V supply, the logic thresholds are $V_{IH} = 2.0V$ and $V_{IL} = 0.6V$.

Dual Supplies

The MAX4711/MAX4712/MAX4713 operate with bipolar supplies between ±2.7V and ±5.5V. The V+ and V- supplies need not be symmetrical, but their difference should not exceed 11V.

Single Supply

The MAX4711/MAX4712/MAX4713 operate from a single supply between +2.7V and +11V when V- is connected to GND.

Chip Information

TRANSISTOR COUNT: 463

Ordering Information (continued)

PART	TEMP RANGE	PIN-PACKAGE
MAX4712CUE	0°C to +70°C	16 TSSOP
MAX4712CSE	0°C to +70°C	16 Narrow SO
MAX4712CPE	0°C to +70°C	16 Plastic Dip
MAX4712EUE	-40°C to +85°C	16 TSSOP
MAX4712ESE	-40°C to +85°C	16 Narrow SO
MAX4712EPE	-40°C to +85°C	16 Plastic Dip
MAX4713CUE	0°C to +70°C	16 TSSOP
MAX4713CSE	0°C to +70°C	16 Narrow SO
MAX4713CPE	0°C to +70°C	16 Plastic Dip
MAX4713EUE	-40°C to +85°C	16 TSSOP
MAX4713ESE	-40°C to +85°C	16 Narrow SO
MAX4713EPE	-40°C to +85°C	16 Plastic Dip

Pin Configurations/Functional Diagrams/Truth Tables (continued)

TOP VIEW

DIP/SO/TSSOP

MAX4712	
LOGIC	SWITCH
0	OFF
1	ON

DIP/SO/TSSOP

MAX4713		
LOGIC	SWITCHES 1, 4	SWITCHES 2, 3
0	OFF	ON
1	ON	OFF

SWITCHES SHOWN FOR LOGIC "0" INPUT

Fault-Protected, Low-Voltage, Quad SPST Analog Switches

Test Circuits/Timing Diagrams

MAX4711/MAX4712/MAX4713

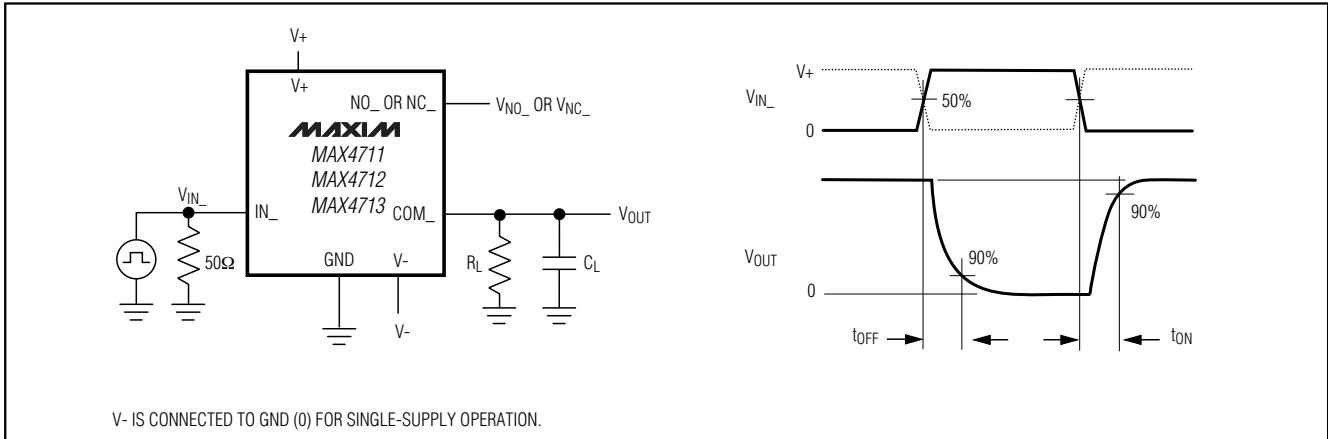

Figure 2. Switch Turn-On/Turn-Off Times

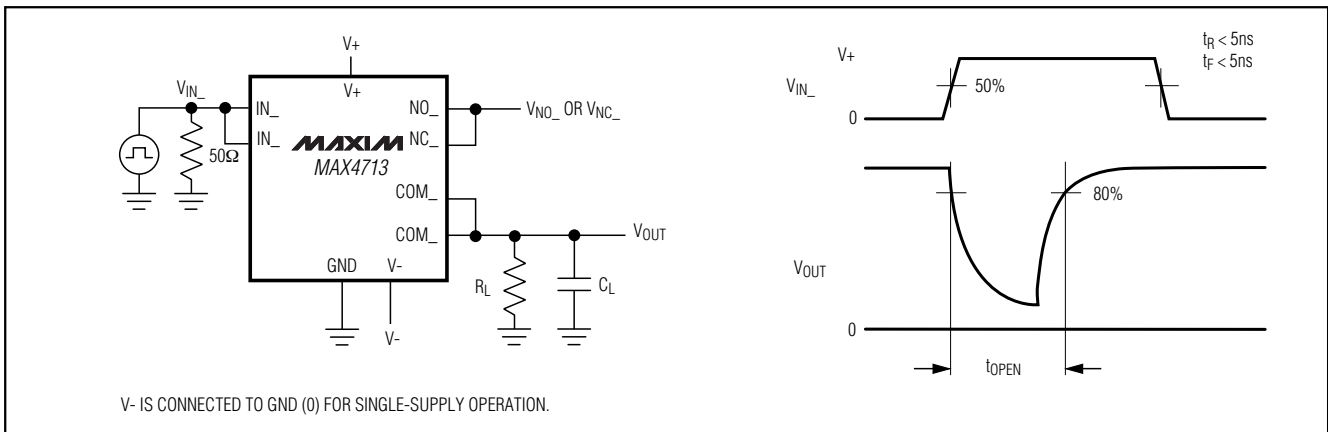

Figure 3. MAX4713 Break-Before-Make Interval

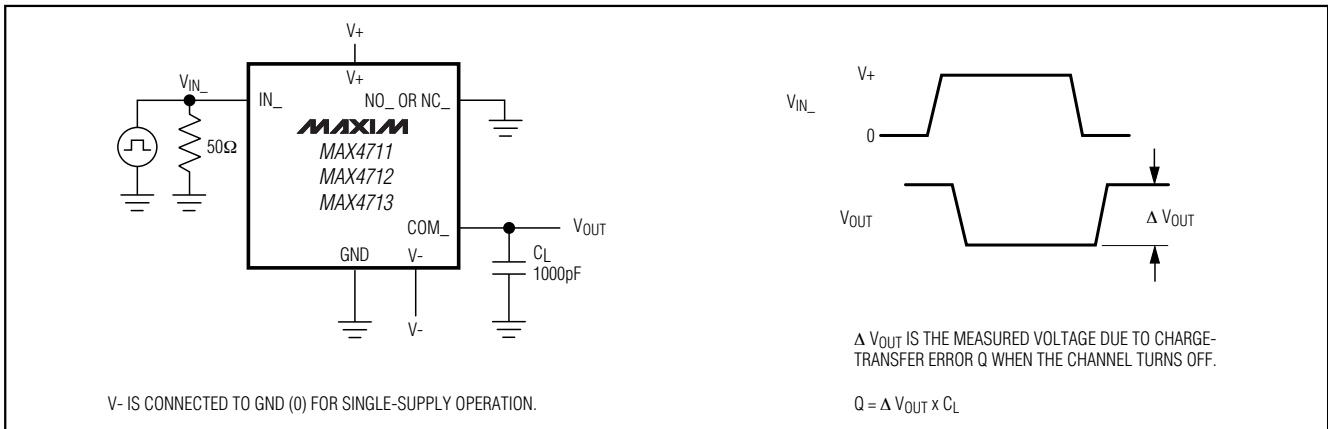

Figure 4. Charge Injection

Fault-Protected, Low-Voltage, Quad SPST Analog Switches

Test Circuits/Timing Diagrams (continued)

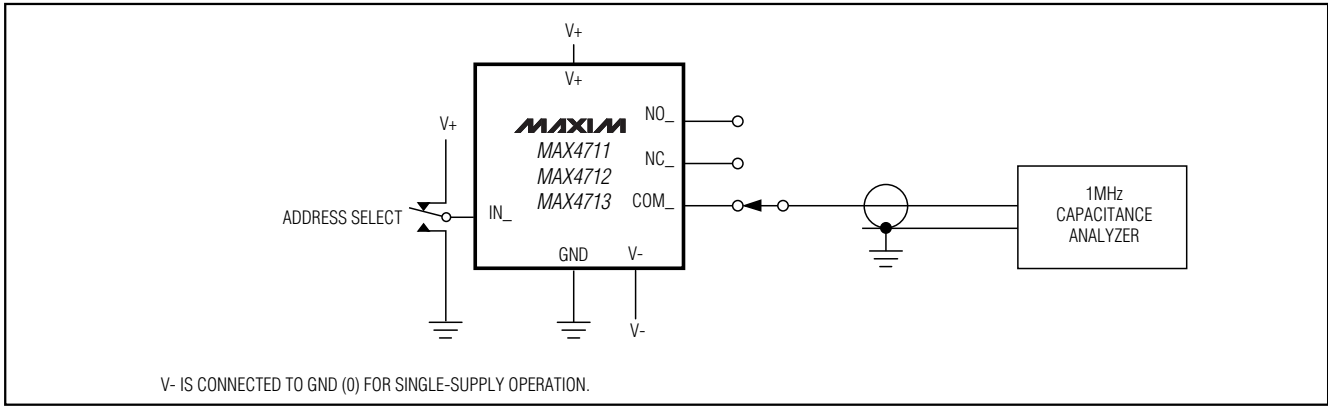

Figure 5. COM_, NO_, NC_ Capacitance

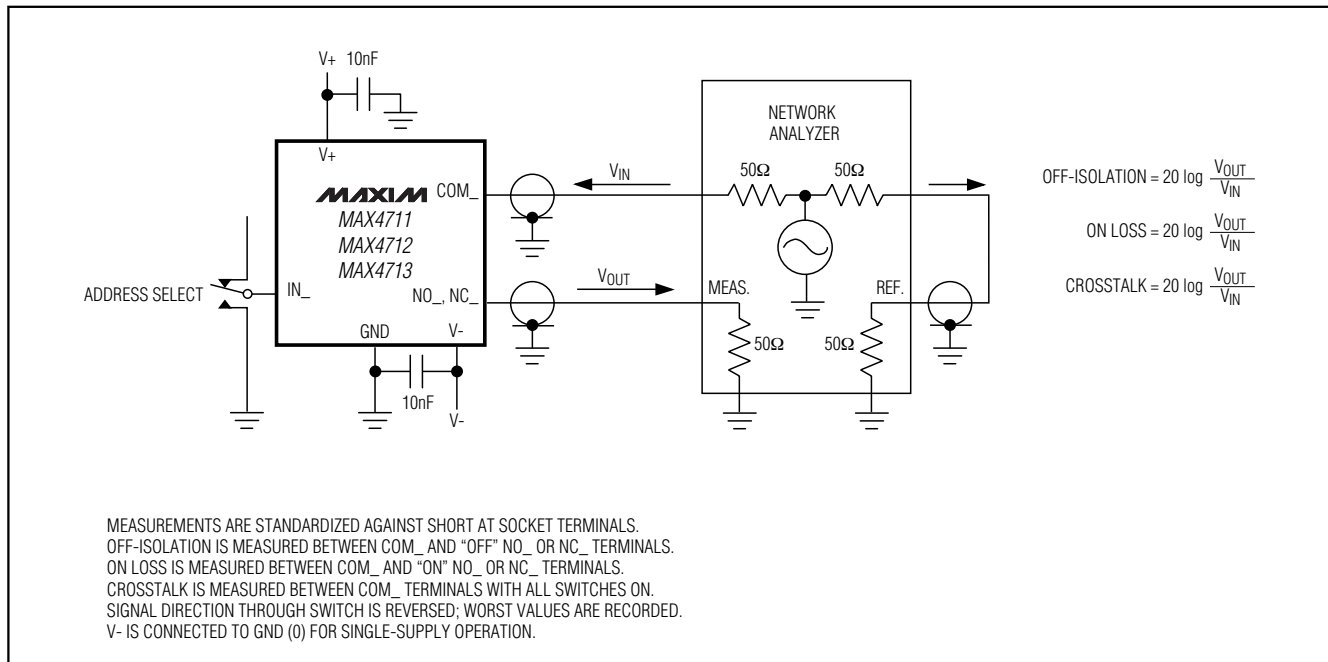

Figure 6. Frequency Response, Off-Isolation, and Crosstalk

Fault-Protected, Low-Voltage, Quad SPST Analog Switches

Package Information

(The package drawing(s) in this data sheet may not reflect the most current specifications. For the latest package outline information go to www.maxim-ic.com/packages.)

MAX4711/MAX4712/MAX4713

TSSOP4, 4.40mm BODY

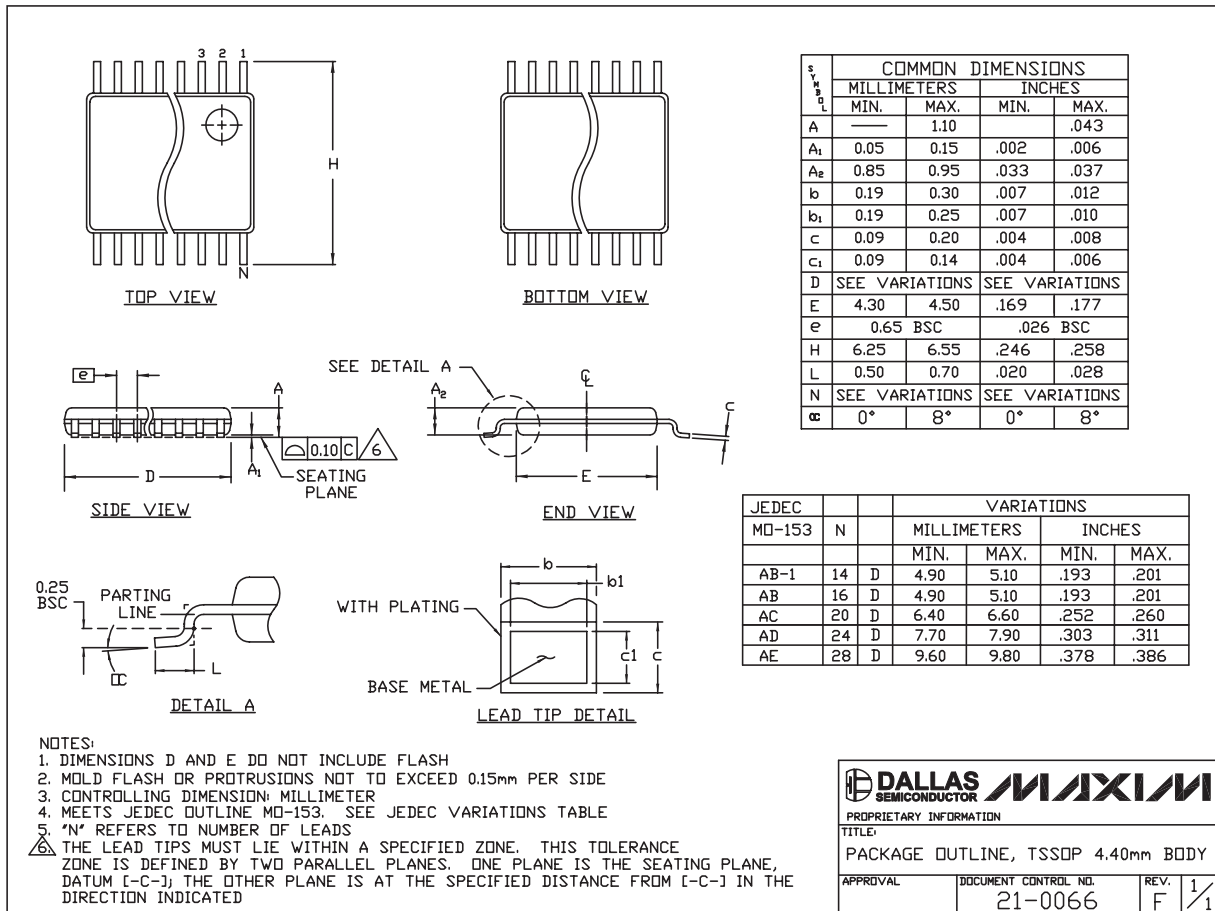

DALLAS SEMICONDUCTOR **MAXIM**

PROPRIETARY INFORMATION

TITLE: PACKAGE OUTLINE, TSSOP 4.40mm BODY

APPROVAL	DOCUMENT CONTROL NO.	REV.	1/1
	21-0066	F	

Fault-Protected, Low-Voltage, Quad SPST Analog Switches

Package Information (continued)

(The package drawing(s) in this data sheet may not reflect the most current specifications. For the latest package outline information go to www.maxim-ic.com/packages.)

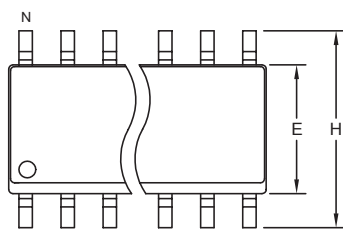

TOP VIEW

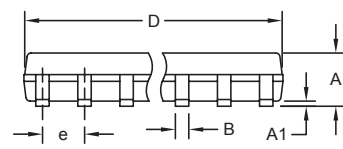

FRONT VIEW

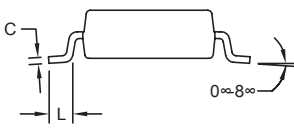

SIDE VIEW

DIM	INCHES		MILLIMETERS	
	MIN	MAX	MIN	MAX
A	0.053	0.069	1.35	1.75
A1	0.004	0.010	0.10	0.25
B	0.014	0.019	0.35	0.49
C	0.007	0.010	0.19	0.25
e	0.050 BSC		1.27 BSC	
E	0.150	0.157	3.80	4.00
H	0.228	0.244	5.80	6.20
L	0.016	0.050	0.40	1.27

VARIATIONS:

DIM	INCHES		MILLIMETERS		N	MS012
	MIN	MAX	MIN	MAX		
D	0.189	0.197	4.80	5.00	8	AA
D	0.337	0.344	8.55	8.75	14	AB
D	0.386	0.394	9.80	10.00	16	AC

NOTES:

1. D&E DO NOT INCLUDE MOLD FLASH.
2. MOLD FLASH OR PROTRUSIONS NOT TO EXCEED 0.15mm (.006").
3. LEADS TO BE COPLANAR WITHIN 0.10mm (.004").
4. CONTROLLING DIMENSION: MILLIMETERS.
5. MEETS JEDEC MS012.
6. N = NUMBER OF PINS.

DALLAS SEMICONDUCTOR		MAXIM	
<small>PROPRIETARY INFORMATION</small>			
<small>TITLE:</small>			
PACKAGE OUTLINE, .150" SOIC			
<small>APPROVAL</small>	<small>DOCUMENT CONTROL NO.</small>	<small>REV.</small>	
	21-0041	B	1/1

SOICN EPSS

Fault-Protected, Low-Voltage, Quad SPST Analog Switches

Package Information (continued)

(The package drawing(s) in this data sheet may not reflect the most current specifications. For the latest package outline information go to www.maxim-ic.com/packages.)

MAX4711/MAX4712/MAX4713

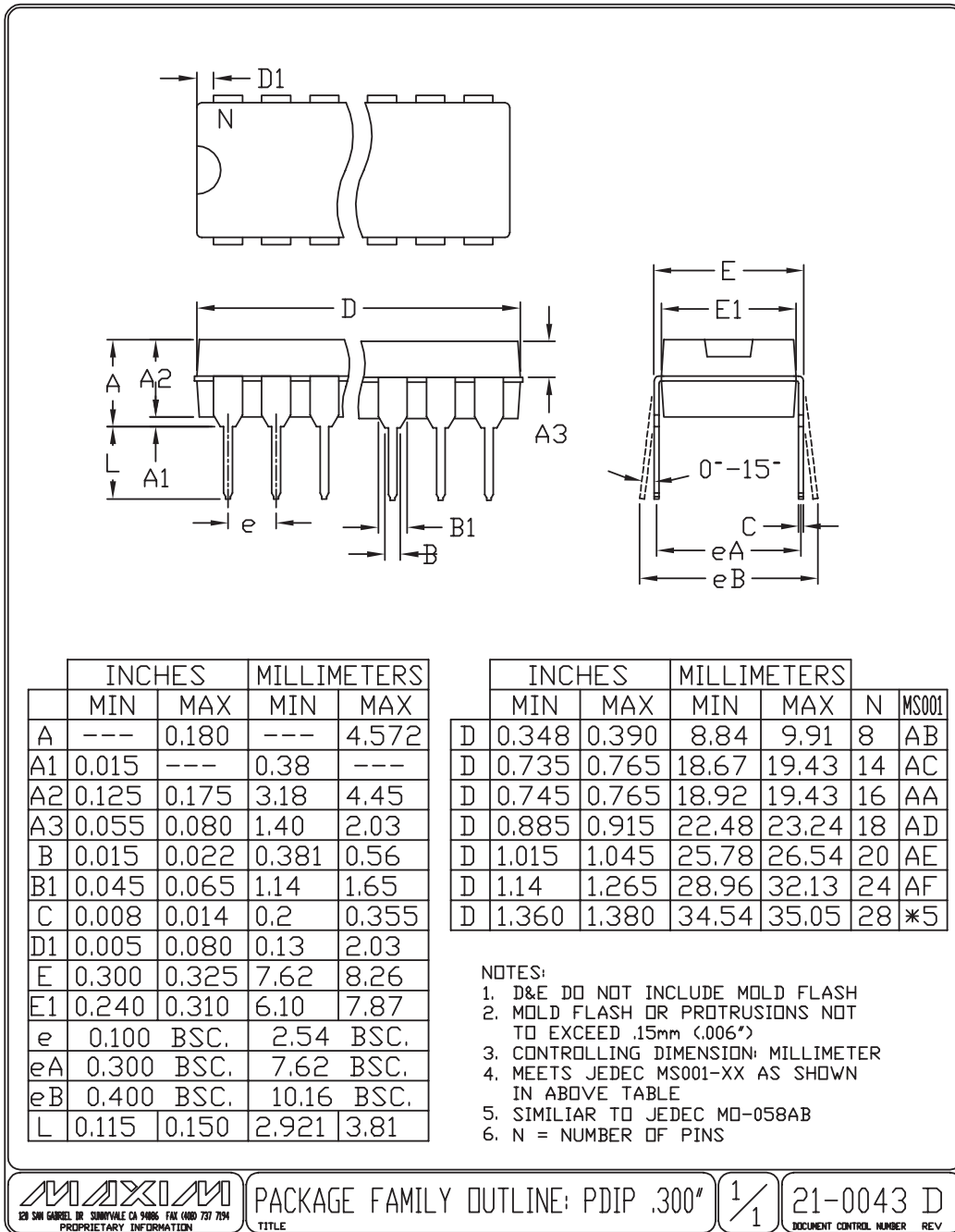

Maxim cannot assume responsibility for use of any circuitry other than circuitry entirely embodied in a Maxim product. No circuit patent licenses are implied. Maxim reserves the right to change the circuitry and specifications without notice at any time.

Maxim Integrated Products, 120 San Gabriel Drive, Sunnyvale, CA 94086 408-737-7600 17