

**Table 1. SKY13392-359LF Signal Descriptions**

Pin #	Name	Description	Pin #	Name	Description
1	RF4	RF output 4. A DC blocking capacitor is required.	9	RF2	RF output 2. A DC blocking capacitor is required.
2	GND	Ground	10	GND	Ground
3	GND	Ground	11	GND	Ground
4	RF3	RF output 3. A DC blocking capacitor is required.	12	RF1	RF output 1. A DC blocking capacitor is required.
5	GND	Ground	13	GND	Ground
6	VDD	Supply voltage input	14	GND	Ground
7	VC1	Control signal 1. See Table 4.	15	RFC	RF common port. A DC blocking capacitor is required.
8	VC2	Control signal 2. See Table 4.	16	GND	Ground

**Table 2. SKY13392-359LF Absolute Maximum Ratings**

Parameter	Symbol	Minimum	Maximum	Units
Supply voltage	V <sub>DD</sub>		5.5	V
Input power	P <sub>IN</sub>		+32	dBm
Control voltage (VC1, VC2)	V <sub>CTL</sub>		V <sub>DD</sub>	V
Operating temperature	T <sub>OP</sub>	-40	+85	°C
Storage temperature	T <sub>STG</sub>	-40	+125	°C

**Note:** Exposure to maximum rating conditions for extended periods may reduce device reliability. There is no damage to device with only one parameter set at the limit and all other parameters set at or below their nominal value. Exceeding any of the limits listed here may result in permanent damage to the device.

**CAUTION:** Although this device is designed to be as robust as possible, Electrostatic Discharge (ESD) can damage this device. This device must be protected at all times from ESD. Static charges may easily produce potentials of several kilovolts on the human body or equipment, which can discharge without detection. Industry-standard ESD precautions should be used at all times.

## Functional Description

The SKY13392-359LF is comprised of a CMOS decoder that enables two TTL-compatible DC lines to control four RF ports. The decoder is internally connected to a GaAs pHEMT RF switch. Depending on the logic voltage level applied to the control pins, the RFC pin is connected to one of four switched RF outputs (RF1, RF2, RF3, or RF4) by a low insertion loss path, while maintaining a high isolation path to the alternate port.

The CMOS decoder should have V<sub>DD</sub> applied before a logic high is applied to one of the control lines.

The recommended startup sequence is:

Step 1: Apply V<sub>DD</sub>.

Step 2: Apply VC1 and VC2

Step 3: Apply RF input.

The device must be turned off in the reverse order.

## Electrical and Mechanical Specifications

The absolute maximum ratings of the SKY13392-359LF are provided in Table 2. Electrical specifications are provided in Table 3.

The state of the SKY13392-359LF is determined by the logic provided in Table 4.

Typical performance characteristics of the SKY13392-359LF are illustrated in Figures 3 through 9.

**Table 3. SKY13392-359LF Electrical Specifications (1 of 2) (Note 1)****(V<sub>DD</sub> = 5 V, VC1 = VC2 = V<sub>DD</sub>, T<sub>OP</sub> = +25 °C, All Unused RF Ports are Terminated in a 50 Ω Load, Unless Otherwise Noted)**

Parameter	Symbol	Test Condition	Min	Typical	Max	Units
<b>RF Specifications</b>						
Insertion loss	IL	0.02 to 1.0 GHz		0.9	1.1	dB
		1.0 to 2.0 GHz		1.0	1.2	dB
		2.0 to 2.7 GHz		1.2	1.4	dB
		2.7 to 4.0 GHz		1.5	1.9	dB
Isolation	ISO	0.02 to 1.0 GHz	55	60		dB
		1.0 to 2.0 GHz	50	54		dB
		2.0 to 2.7 GHz	47	50		dB
		2.7 to 4.0 GHz	40	46		dB
Return loss (insertion loss state) (Note 2)	IS11I	0.02 to 2.7 GHz, all RF ports		15		dB
		2.7 to 4.0 GHz		9		dB
Return loss (isolation state)	IS22I	0.5 to 4.0 GHz		14		dB
1 dB Input Compression Point	P1dB	0.3 to 4.0 GHz, V <sub>DD</sub> = 5 V		+30		dBm
3 <sup>rd</sup> Order Input Intercept Point	IIP3	Two tones, +7 dBm per tone, 0.3 to 4.0 GHz, 1 MHz spacing		+47		dBm
Switching speed	T <sub>RISE</sub> , T <sub>FALL</sub>	10/90% RF rise/fall time		21		ns
	T <sub>ON</sub> , T <sub>OFF</sub>	50 % V <sub>CTL</sub> to 10/90% on/off time		125		ns
<b>DC/Control Specifications</b>						
Supply voltage	V <sub>DD</sub>		3		5	V
Supply current	I <sub>DD</sub>			350		μA
Control voltage (VC1, VC2):	V <sub>CTL</sub>		2.5	High	3.0	V <sub>DD</sub>
				Low	0	0.8
Control current:	I <sub>CTL</sub>			High	5	μA
				Low	5	μA

**Note 1:** Performance is guaranteed only under the conditions listed in this Table.**Note 2:** Return loss in the insertion loss state is dependent on the value of DC blocking capacitors.**Table 4. SKY13392-359LF Truth Table**

State	VC1 (Pin 7)	VC2 (Pin 8)	RF Path
1	V <sub>LOW</sub>	V <sub>LOW</sub>	RFC to RF1
2	V <sub>LOW</sub>	V <sub>HIGH</sub>	RFC to RF2
3	V <sub>HIGH</sub>	V <sub>LOW</sub>	RFC to RF3
4	V <sub>HIGH</sub>	V <sub>HIGH</sub>	RFC to RF4

**Note:** V<sub>HIGH</sub> = 2.5 V to V<sub>DD</sub>V<sub>LOW</sub> = 0 to 0.8 V

Any state other than described in this Table places the switch into an undefined state.

### Typical Performance Characteristics

( $V_{DD} = 5\text{ V}$ ,  $CTRL1 = CTRL2 = V_{DD}$ ,  $T_{OP} = +25\text{ }^{\circ}\text{C}$ ,  $P_{IN} = 0\text{ dBm}$ , Blocking Capacitors = 100 pF, Unless Otherwise Noted)

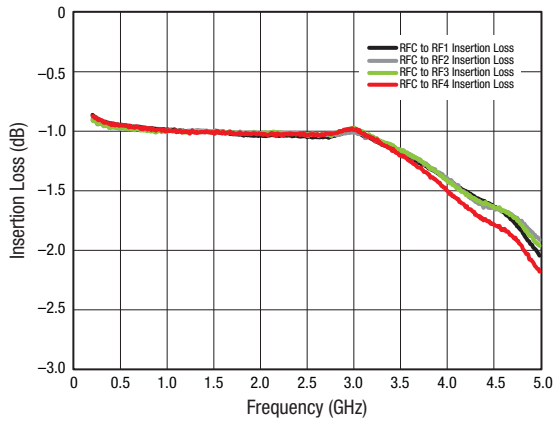

**Figure 3. Insertion Loss vs Frequency**

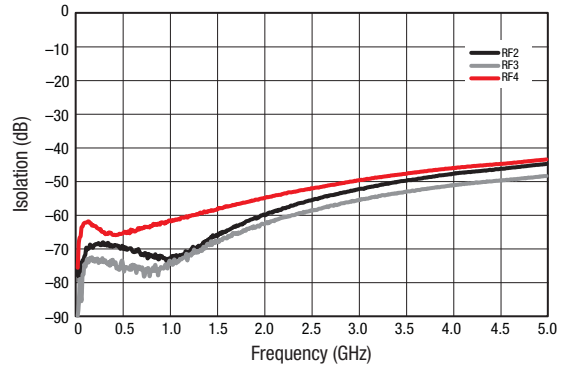

**Figure 4. Isolation vs Frequency (RFC to RF1 "On")**

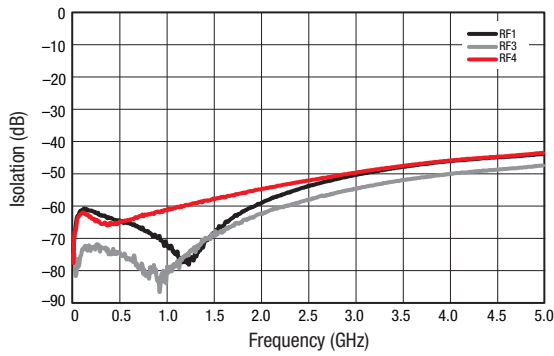

**Figure 5. Isolation vs Frequency (RFC to RF2 "On")**

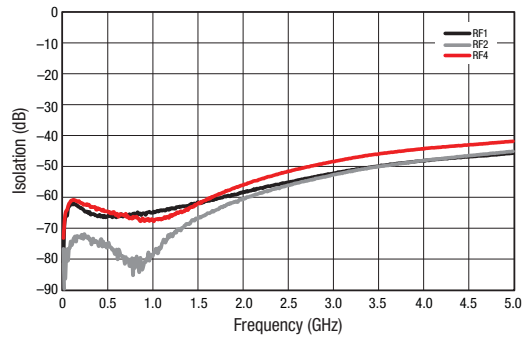

**Figure 6. Isolation vs Frequency (RFC to RF3 "On")**

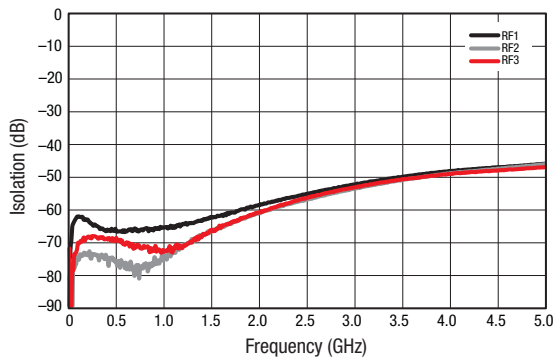

**Figure 7. Isolation vs Frequency (RFC to RF4 "On")**

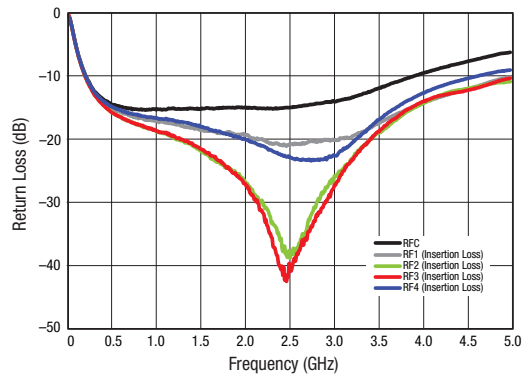

**Figure 8. Return Loss vs Frequency (Insertion Loss States)**

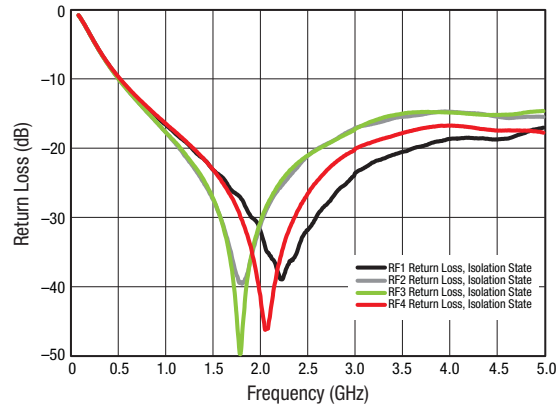

**Figure 9. Return Loss vs Frequency  
(Isolation States)**

### Evaluation Board Description

The SKY13392-359LF Evaluation Board is used to test the performance of the SKY13392-359LF SP4T Switch. An Evaluation Board schematic diagram is provided in Figure 10. An assembly drawing for the Evaluation Board is shown in Figure 11.

### Package Dimensions

The PCB layout footprint for the SKY13392-359LF is provided in Figure 12. Typical case markings are shown in Figure 13. Package dimensions for the 16-pin QFN are shown in Figure 14, and tape and reel dimensions are provided in Figure 15.

### Package and Handling Information

Instructions on the shipping container label regarding exposure to moisture after the container seal is broken must be followed. Otherwise, problems related to moisture absorption may occur when the part is subjected to high temperature during solder assembly.

THE SKY13392-359LF is rated to Moisture Sensitivity Level 1 (MSL1) at 260 °C. It can be used for lead or lead-free soldering. For additional information, refer to the Skyworks Application Note, *Solder Reflow Information*, document number 200164.

Care must be taken when attaching this product, whether it is done manually or in a production solder reflow environment. Production quantities of this product are shipped in a standard tape and reel format.

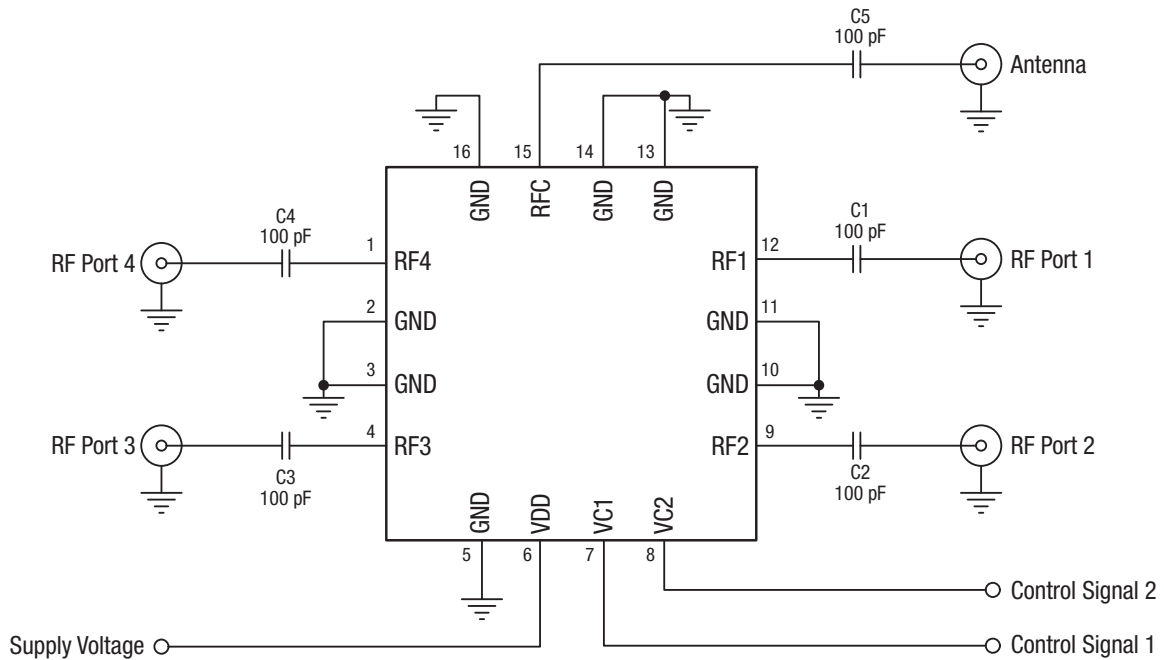

*Note: To operate at <500 MHz, the values of all capacitors must be increased to maintain return loss in the insertion loss state. The return loss in an isolation state degrades at low frequencies due to limitations of on-chip capacitors.*

S2547

**Figure 10. SKY13392-359LF Evaluation Board Schematic**

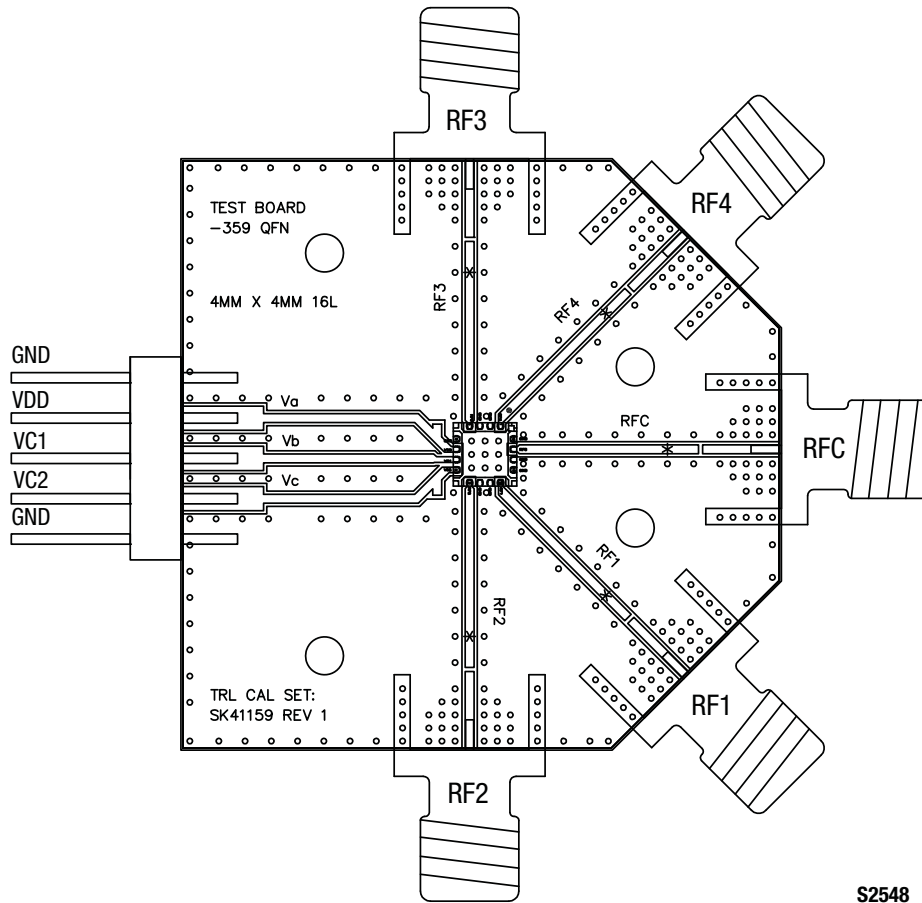

S2548

**Figure 11. SKY13392-359LF Evaluation Board Assembly Diagram**

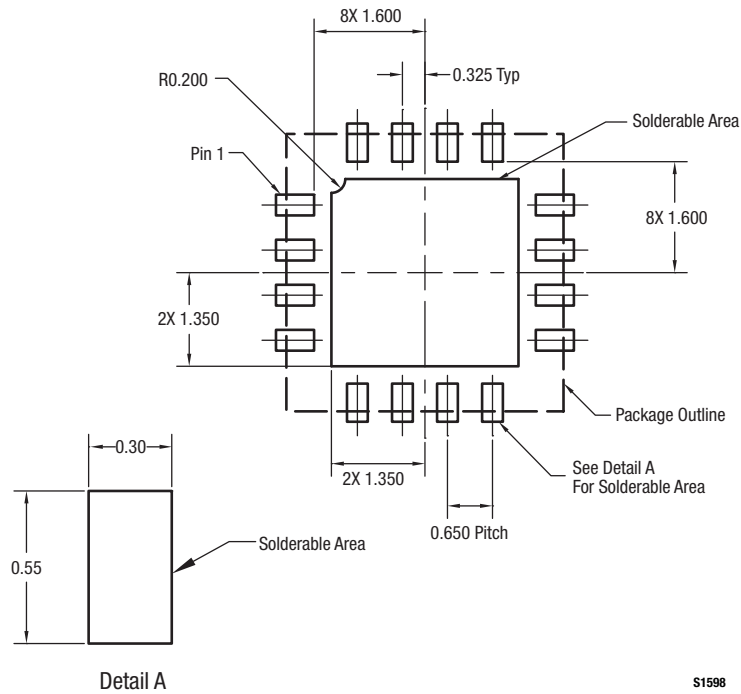

**Figure 12. SKY13392-359LF PCB Layout Footprint (Top View)**

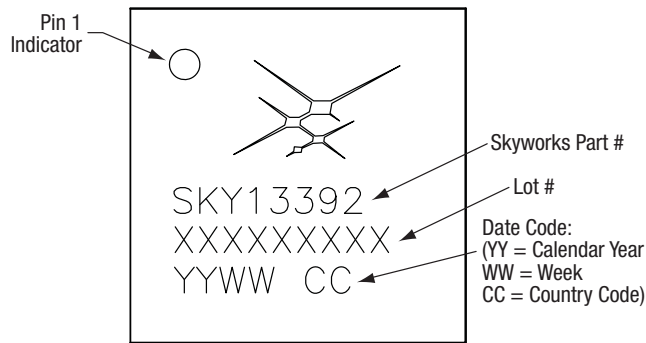

**Figure 13. Typical Case Markings (Top View)**

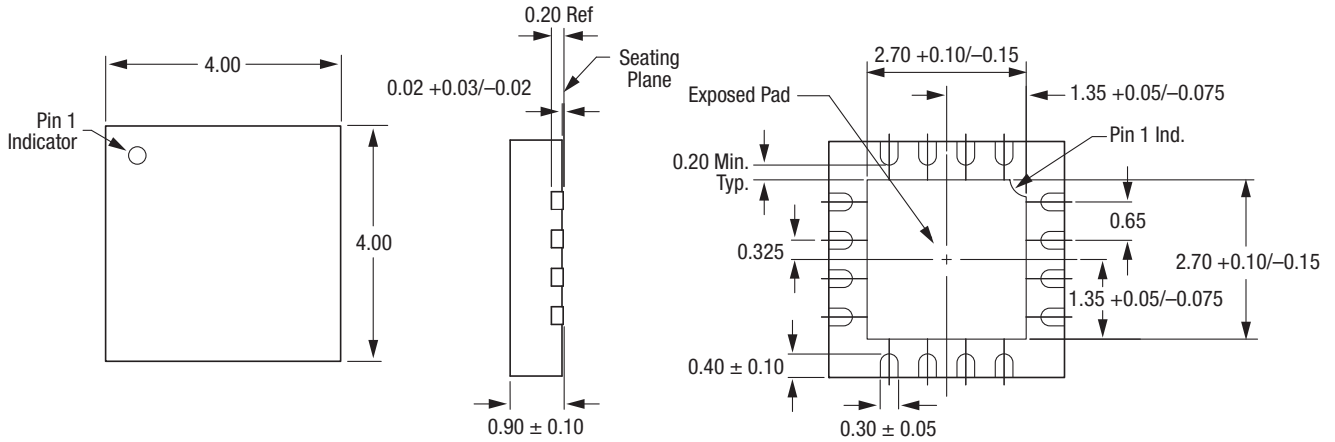

All dimensions are in millimeters

S1596

Figure 14. SKY13392-359LF 16-Pin QFN Package Dimensions

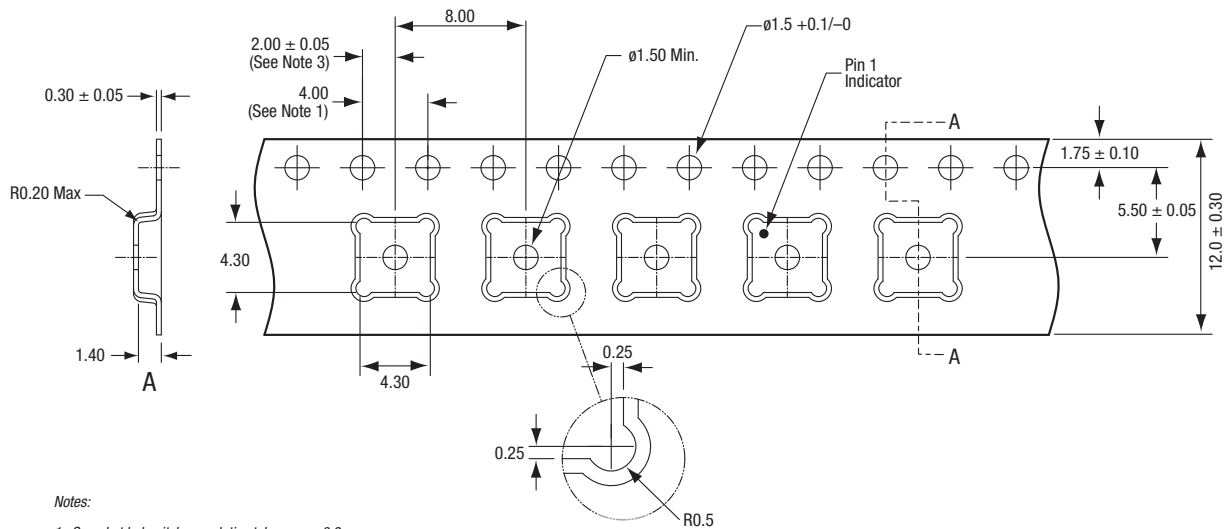

Notes:

1. Sprocket hole pitch cumulative tolerance:  $\pm 0.2$ .
2. Carrier tape: black conductive polystyrene.
3. Pocket position relative to sprocket hole, measure as true position of pocket, not pocket hole.
4. Cover tape material: transparent conductive PSA, 9.20 mm wide.
5. All dimensions are in millimeters.

S2990

Figure 15. SKY13392-359LF Tape and Reel Dimensions



## Ordering Information

Model Name	Manufacturing Part Number	Evaluation Board Part Number
SKY13392-359LF SP4T Switch	SKY13392-359LF	SKY13392-359LF-EVB

Copyright © 2012-2013 Skyworks Solutions, Inc. All Rights Reserved.

Information in this document is provided in connection with Skyworks Solutions, Inc. ("Skyworks") products or services. These materials, including the information contained herein, are provided by Skyworks as a service to its customers and may be used for informational purposes only by the customer. Skyworks assumes no responsibility for errors or omissions in these materials or the information contained herein. Skyworks may change its documentation, products, services, specifications or product descriptions at any time, without notice. Skyworks makes no commitment to update the materials or information and shall have no responsibility whatsoever for conflicts, incompatibilities, or other difficulties arising from any future changes.

No license, whether express, implied, by estoppel or otherwise, is granted to any intellectual property rights by this document. Skyworks assumes no liability for any materials, products or information provided hereunder, including the sale, distribution, reproduction or use of Skyworks products, information or materials, except as may be provided in Skyworks Terms and Conditions of Sale.

THE MATERIALS, PRODUCTS AND INFORMATION ARE PROVIDED "AS IS" WITHOUT WARRANTY OF ANY KIND, WHETHER EXPRESS, IMPLIED, STATUTORY, OR OTHERWISE, INCLUDING FITNESS FOR A PARTICULAR PURPOSE OR USE, MERCHANTABILITY, PERFORMANCE, QUALITY OR NON-INFRINGEMENT OF ANY INTELLECTUAL PROPERTY RIGHT; ALL SUCH WARRANTIES ARE HEREBY EXPRESSLY DISCLAIMED. SKYWORKS DOES NOT WARRANT THE ACCURACY OR COMPLETENESS OF THE INFORMATION, TEXT, GRAPHICS OR OTHER ITEMS CONTAINED WITHIN THESE MATERIALS. SKYWORKS SHALL NOT BE LIABLE FOR ANY DAMAGES, INCLUDING BUT NOT LIMITED TO ANY SPECIAL, INDIRECT, INCIDENTAL, STATUTORY, OR CONSEQUENTIAL DAMAGES, INCLUDING WITHOUT LIMITATION, LOST REVENUES OR LOST PROFITS THAT MAY RESULT FROM THE USE OF THE MATERIALS OR INFORMATION, WHETHER OR NOT THE RECIPIENT OF MATERIALS HAS BEEN ADVISED OF THE POSSIBILITY OF SUCH DAMAGE.

Skyworks products are not intended for use in medical, lifesaving or life-sustaining applications, or other equipment in which the failure of the Skyworks products could lead to personal injury, death, physical or environmental damage. Skyworks customers using or selling Skyworks products for use in such applications do so at their own risk and agree to fully indemnify Skyworks for any damages resulting from such improper use or sale.

Customers are responsible for their products and applications using Skyworks products, which may deviate from published specifications as a result of design defects, errors, or operation of products outside of published parameters or design specifications. Customers should include design and operating safeguards to minimize these and other risks. Skyworks assumes no liability for applications assistance, customer product design, or damage to any equipment resulting from the use of Skyworks products outside of stated published specifications or parameters.

Skyworks, the Skyworks symbol, and "Breakthrough Simplicity" are trademarks or registered trademarks of Skyworks Solutions, Inc., in the United States and other countries. Third-party brands and names are for identification purposes only, and are the property of their respective owners. Additional information, including relevant terms and conditions, posted at [www.skyworksinc.com](http://www.skyworksinc.com), are incorporated by reference.

# Mouser Electronics

Authorized Distributor

Click to View Pricing, Inventory, Delivery & Lifecycle Information:

Skyworks:

[SKY13392-359LF](#) [SKY13392-359LF-EVB](#)