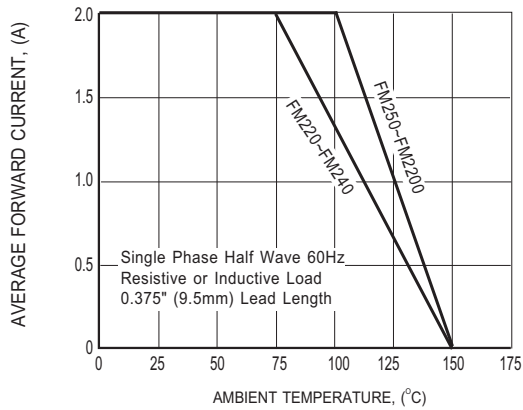
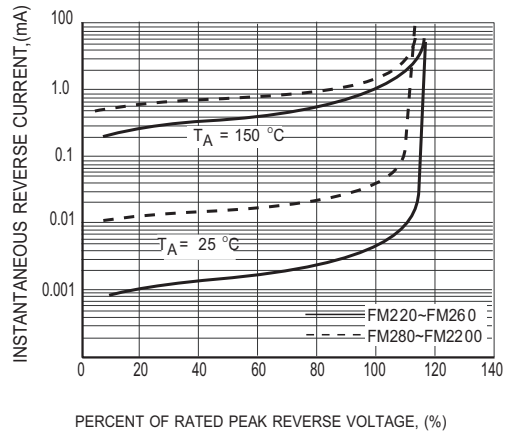


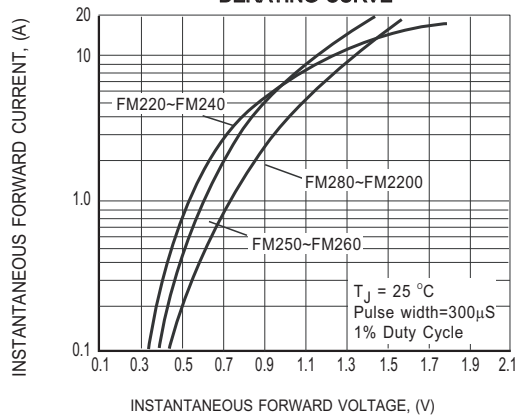
# RATING AND CHARACTERISTICS CURVES ( FM220 THRU FM2200 )



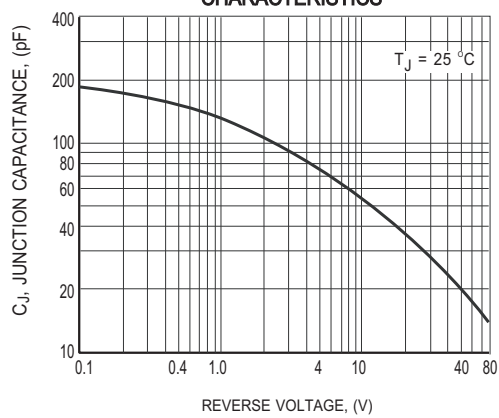
**FIG.1 TYPICAL FORWARD CURRENT DERATING CURVE**



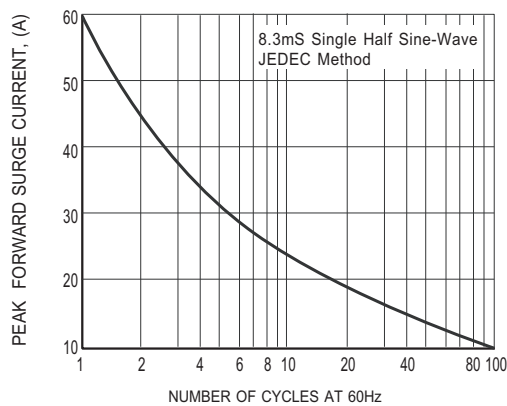
**FIG.2 MAXIMUM REVERSE CHARACTERISTICS**



**FIG.3 MAXIMUM INSTANTANEOUS FORWARD CHARACTERISTICS**

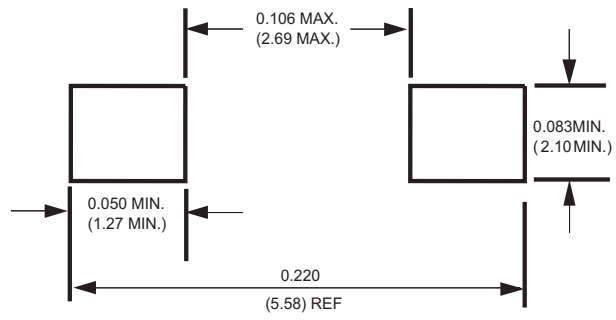


**FIG.4 TYPICAL JUNCTION CAPACITANCE**



**FIG.5 MAXIMUM NON-REPETITIVE FORWARD SURGE CURRENT**

## Mounting Pad Layout



Dimensions in inches and (millimeters)

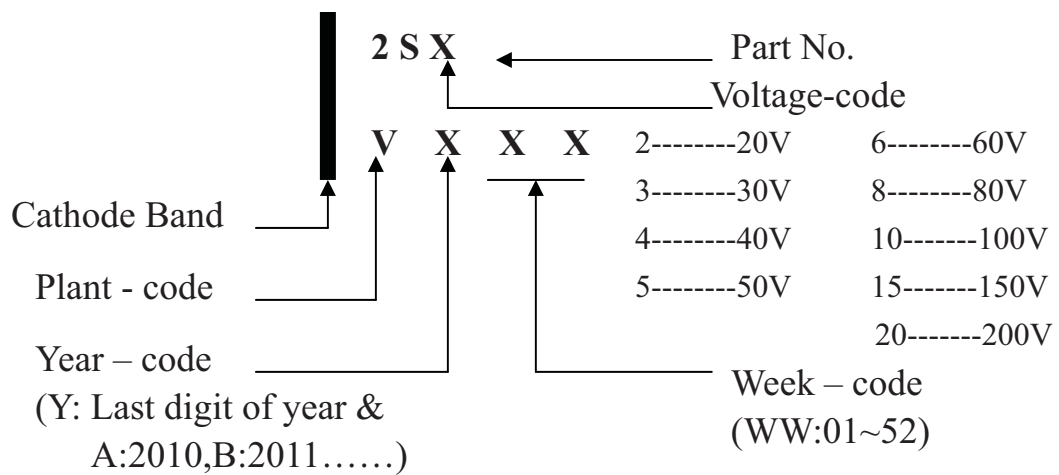


## Attachment information about FM2XX

### 1. Internal Circuit



### 2. Marking on the body





## **Attachment information about FM2XX**

### **3. Items marked on the reel box and carton**

#### **3.1 On the reel (for -T & -W)**

**CUSTOMER**

**TYPE**

**QUANTITY**

**LOT NO.**

**Q.A.**

**REMARK**

#### **3.2 On the box (for -T & -W)**

**TYPE**

**QUANTITY**

**LOT NO.**

**Q.A.**

#### **3.3 On the carton**

**CUSTOMER**

**TYPE**

**QUANTITY**

**LOT NO.**

**REMARK**

# REEL TAPING SPECIFICATIONS FOR SURFACE MOUNT DEVICES-FLAT MELF ( SMA/SMB/SMC )

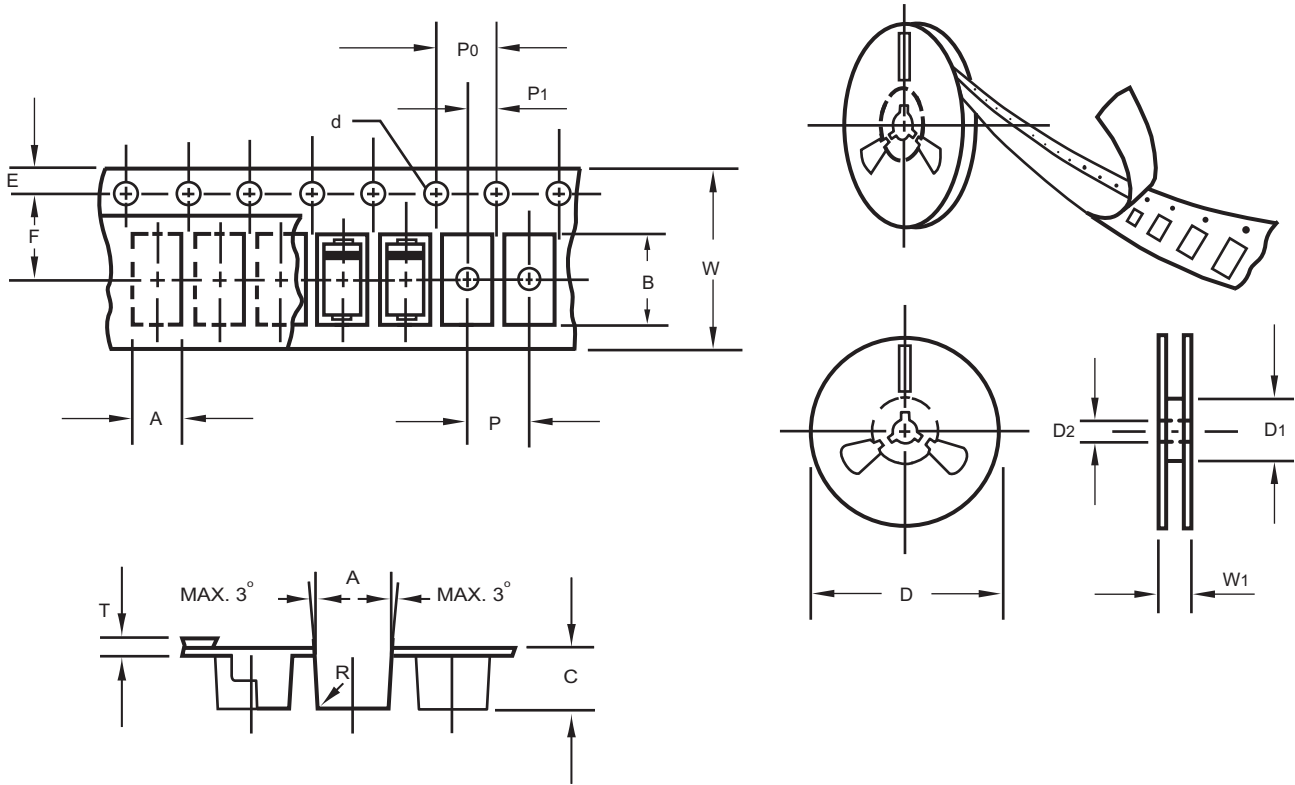
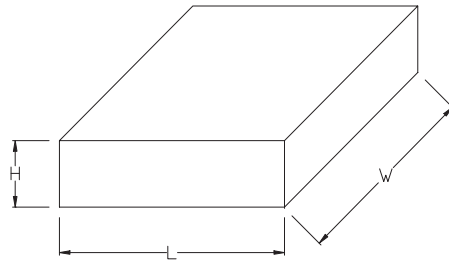


Fig.: Configuration of FLAT MELF TAPING  
( SMA/SMB/SMC )

ITEM	SYMBOL	DO214AC (SMA) mm(inch)	DO214AA (SMB) mm(inch)	DO214AB (SMC) mm(inch)
Carrier width	A	2.6 ± 0.15 (0.102 ± 0.006)	3.65 ± 0.1 (0.144 ± 0.004)	6.0 ± 0.1 (0.236 ± 0.004)
Carrier length	B	5.15 ± 0.15 (0.203 ± 0.006)	5.69 ± 0.1 (0.224 ± 0.004)	8.30 ± 0.1 (0.327 ± 0.004)
Carrier depth	C	2.3 ± 0.15 (0.091 ± 0.006)	2.67 ± 0.1 (0.105 ± 0.004)	2.5 ± 0.1 (0.098 ± 0.004)
Sprocket hole	d	1.5 ± 0.1 (0.059 ± 0.004)	1.5 ± 0.1 (0.059 ± 0.004)	1.5 ± 0.1 (0.059 ± 0.004)
Reel outside diameter	D	178 ± 2.0 (7.0 ± 0.079)	178 ± 2.0 (7.0 ± 0.079)	178 ± 2.0 (7.0 ± 0.079)
Reel inner diameter	D1	50 Min.	50 Min.	50 Min.
Feed hole diameter	D2	13 ± 0.5 (0.512 ± 0.020)	13 ± 0.5 (0.512 ± 0.020)	13 ± 0.5 (0.512 ± 0.020)
Strocket hole position	E	1.5 ± 0.1 (0.059 ± 0.004)	1.5 ± 0.1 (0.059 ± 0.004)	1.5 ± 0.1 (0.059 ± 0.004)
Punch hole position	F	5.65 ± 0.05 (0.222 ± 0.002)	5.65 ± 0.05 (0.222 ± 0.002)	7.65 ± 0.05 (0.301 ± 0.002)
Punch hole pitch	P	4.0 ± 0.1 (0.157 ± 0.004)	8.0 ± 0.1 (0.315 ± 0.004)	8.0 ± 0.1 (0.315 ± 0.004)
Sprocket hole pitch	P0	4.0 ± 0.1 (0.157 ± 0.004)	4.0 ± 0.1 (0.157 ± 0.004)	4.0 ± 0.1 (0.157 ± 0.004)
Embossment center	P1	2.0 ± 0.1 (0.079 ± 0.004)	2.0 ± 0.1 (0.079 ± 0.004)	4.0 ± 0.1 (0.157 ± 0.004)
Total tape thickness	T	0.30 ± 0.05 (0.012 ± 0.002)	0.6 Max.	0.6 Max.
Tape width	W	12.0 ± 0.2 (0.472 ± 0.008)	12.0 ± 0.2 (0.472 ± 0.008)	16.0 ± 0.2 (0.630 ± 0.008)
Reel width	W1	16.8 ± 2.0 (0.661 ± 0.079)	16.8 ± 2.0 (0.661 ± 0.079)	24.0 ± 2.0 (0.945 ± 0.079)

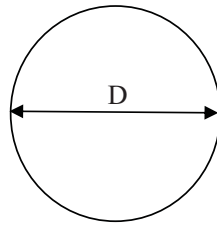
Note: 1.Devices are packed in accordance with EIA standard RS-481-D and specification given above.  
2.Available on 7 inch ( 1500 ct. ) or 13 inch ( 5000 ct. ) diameter reels.

1. BOX



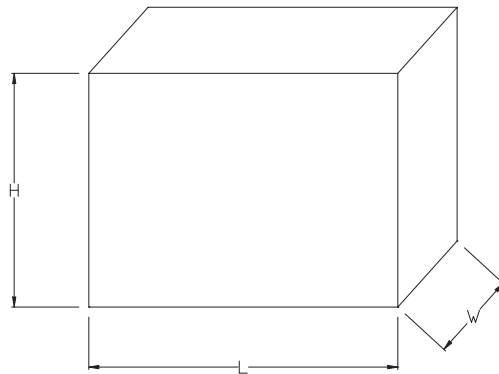
Packing Code	L (mm)	W (mm)	H (mm)
-T	182	182	68
-W	338	338	40

2. REEL



Packing Code	D (mm)
-T	178
-W	330

3. CARTON



Packing Code	L (mm)	W (mm)	H (mm)
-T	390	205	310
-W	360	355	360

## PACKAGING OF DIODE AND BRIDGE RECTIFIERS

### REEL PACK

PACKAGE	PACKING CODE	EA PER REEL	EA PER INNER BOX	COMPONENT SPACE (mm)	TAPE SPACE (mm)	REEL DIA (mm)	CARTON SIZE (mm)	EA PER CARTON	GROSS WEIGHT(Kg)
SMB	-T	500	2,000	---	---	178	390*205*310	16,000	----
SMB	-W	3,000	6,000	---	---	330	360*355*360	48,000	13.90

# Mouser Electronics

Authorized Distributor

Click to View Pricing, Inventory, Delivery & Lifecycle Information:

[Rectron:](#)

[FM280-W](#) [FM250-W](#) [FM240-W](#) [FM260-W](#) [FM2100-W](#) [FM230-W](#) [FM220-W](#) [FM2100](#) [FM220](#) [FM230](#) [FM240](#)  
[FM250](#) [FM260](#) [FM280](#)