

**ABSOLUTE MAXIMUM RATINGS<sup>1</sup>** (T<sub>A</sub> = 25°C)

SYMBOLS	PARAMETERS	UNITS	RATING
<b>Diode</b>			
I <sub>F</sub>	Forward Current	mA	25
V <sub>R</sub>	Reverse Voltage	V	3.0
P <sub>D</sub>	Power Dissipation	mW	45
<b>Detector</b>			
V <sub>CC</sub>	Supply Voltage	V	35
V <sub>O</sub>	Output Voltage	V	35
I <sub>O</sub>	Output Current	mA	8.0
P <sub>C</sub>	Power Dissipation	mW	100
<b>Coupled</b>			
BV	Isolation Voltage <sup>2</sup>	V <sub>r.m.s.</sub>	2500
T <sub>A</sub>	Operating Ambient Temp.	°C	-55 to +100
T <sub>STG</sub>	Storage Temperature	°C	-55 to +125

**Notes:**

1. Operation in excess of any one of these parameters may result in permanent damage.
2. AC voltage for one minute at T<sub>A</sub> = 25°C, RH = 60% between input and output.

**OUTLINE DIMENSIONS** (Units in mm)

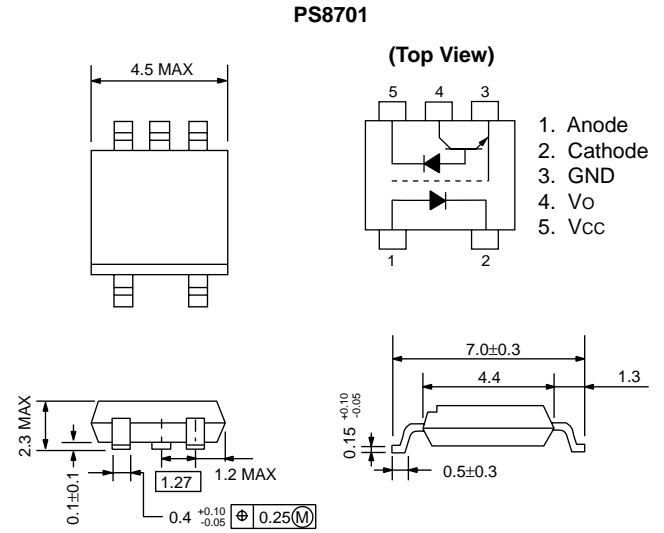

(Continued from previous pages)

**NOTES:**

1. Test Circuit for Propagation Delay Time:

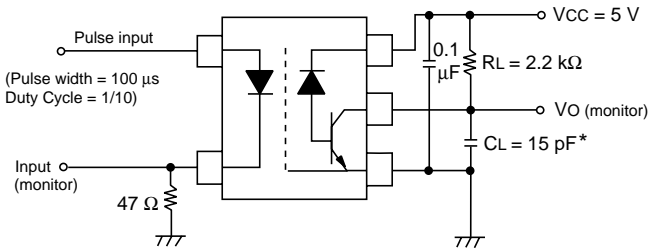

\*CL is approximately 15 pF which includes probe and stray wiring capacitance.

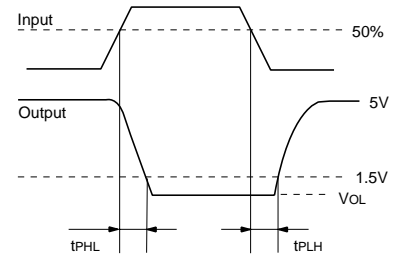

2. Test Circuit for Common Mode Transient Immunity:

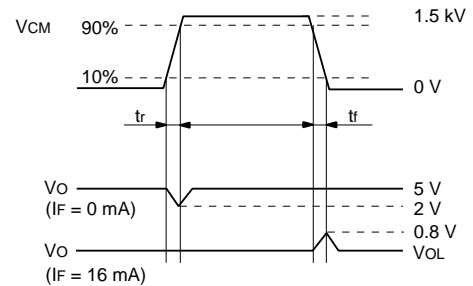
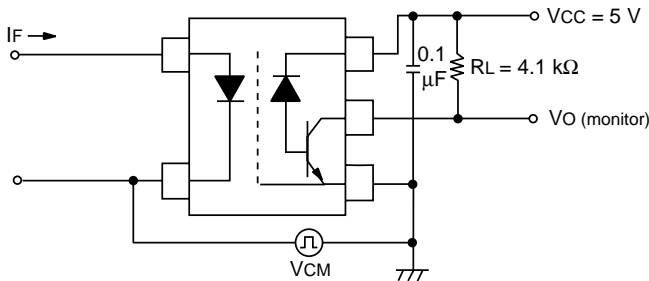

**Usage Cautions:**

1. When handling this product, precautions should be taken against static electricity.
2. A by-pass capacitor of ≥ 0.1 μF is used between V<sub>CC</sub> and GND.

**TYPICAL PERFORMANCE CURVES** ( $T_A = 25\text{ }^\circ\text{C}$ )

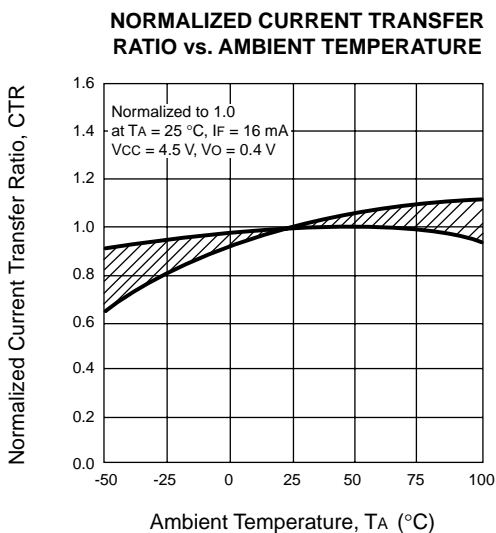
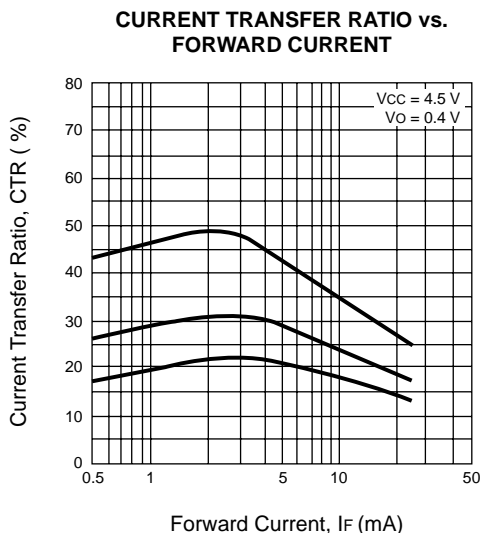
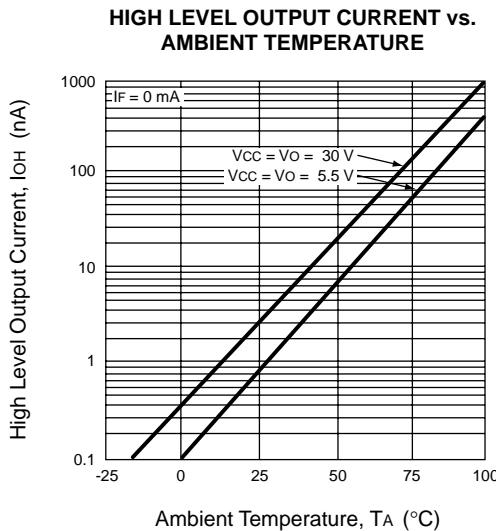
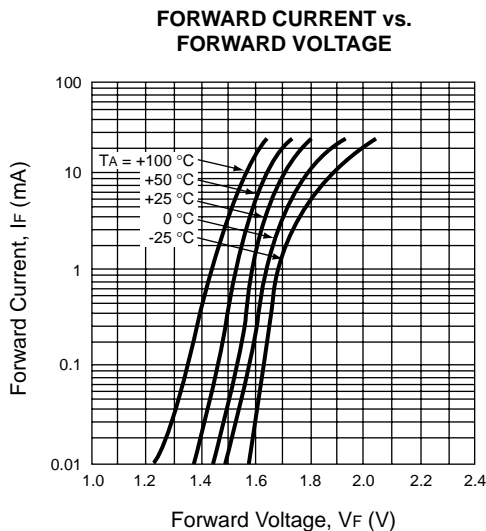
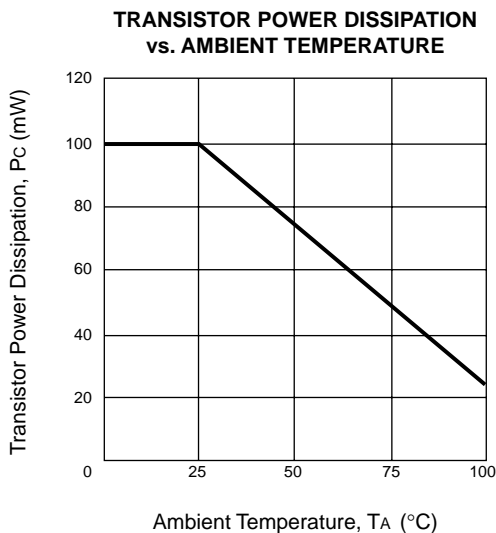
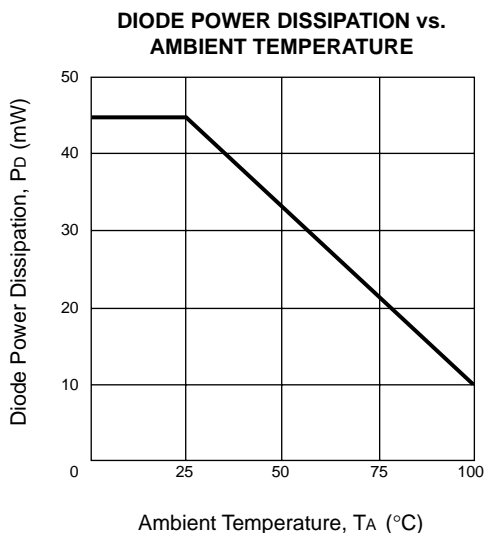

TYPICAL PERFORMANCE CURVES (TA = 25 °C)

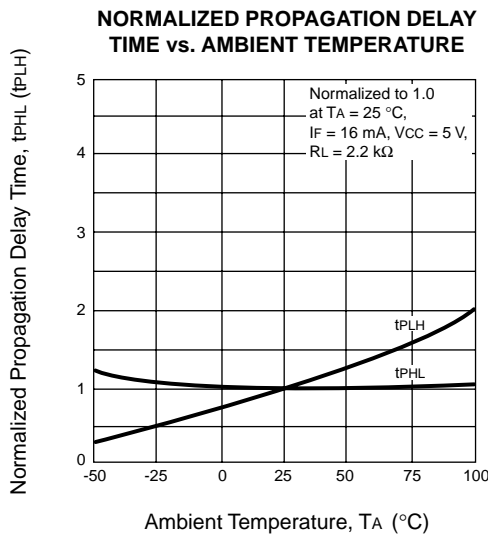
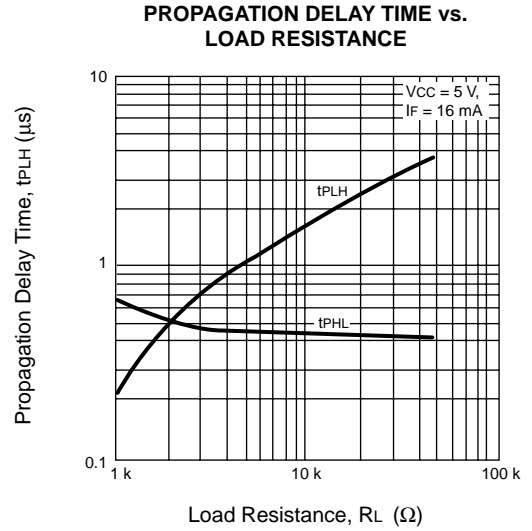
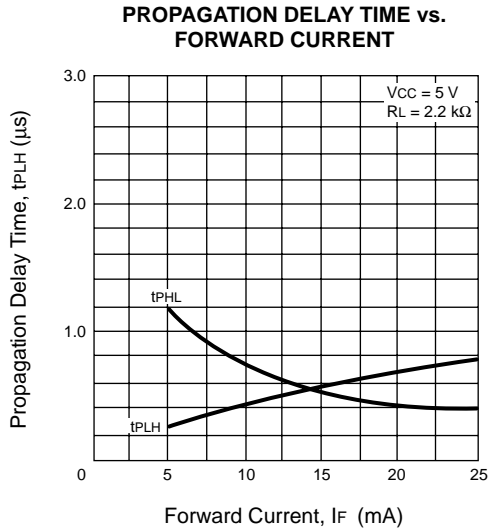
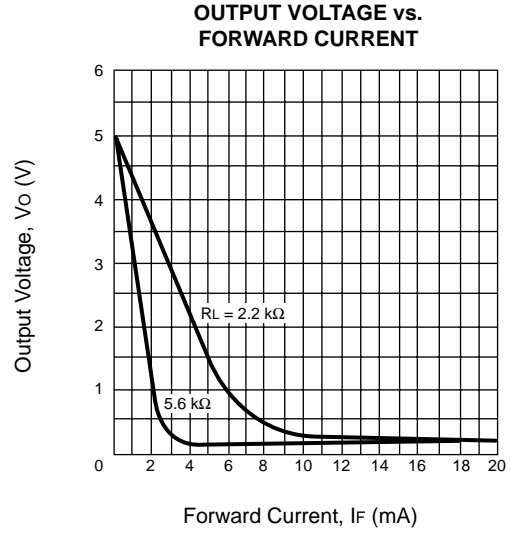
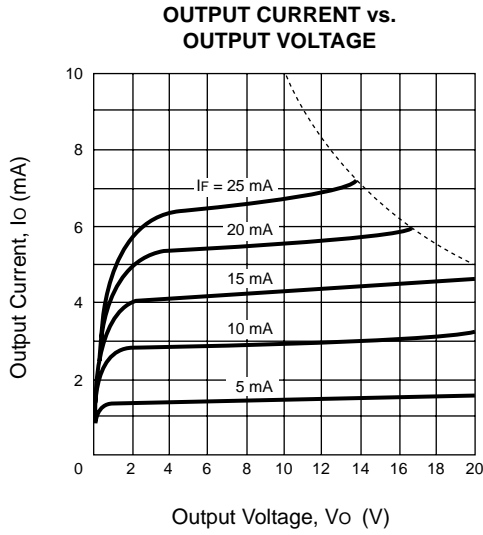

**TAPING SPECIFICATIONS** (Units in mm)

**OUTLINE AND DIMENSIONS (TAPE)**

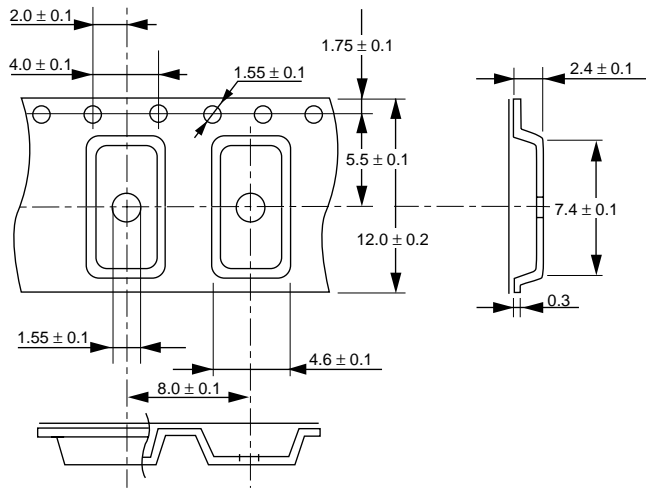

**OUTLINE AND DIMENSIONS (REEL)**

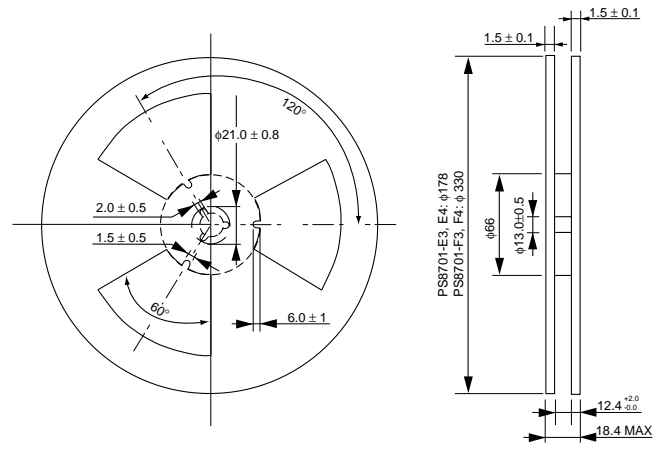

Notes:

1. Packing : PS8701-E3, E4 900 pcs/reel  
PS8701-F3, F4 3500 pcs/reel

**TAPE DIRECTION**

**PS8701-E3  
PS8701-F3**

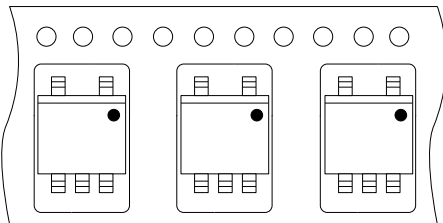

**PS8701-E4  
PS8701-F4**

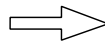
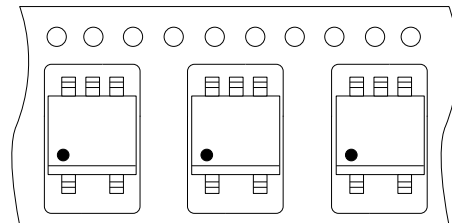

**RECOMMENDED SOLDERING CONDITIONS**

**(1) Infrared reflow soldering**

- **Peak reflow temperature** 235 °C (package surface temperature)
- **Time of temperature higher than 210 °C** 30 seconds or less
- **Number of reflows** Three
- **Flux** Rosin flux containing small amount of chlorine (The flux with a max. chlorine content of 0.2 Wt % is recommended)

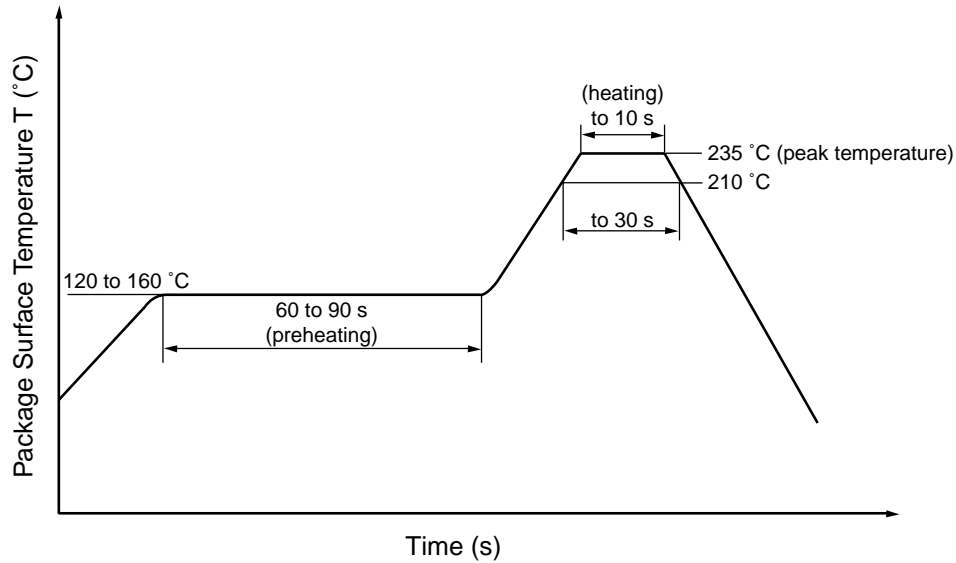

**Caution: Please avoid removing the residual flux by water after the first reflow process.**

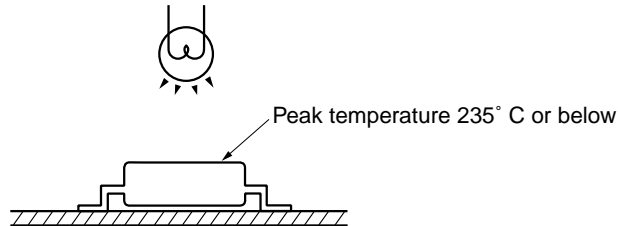

**(2) Dip soldering**

- **Temperature** 260 °C or below (molten solder temperature)
- **Time** 10 seconds or less
- **Number of times** One
- **Flux** Rosin flux containing small amount of chlorine (The flux with a max. chlorine content of 0.2 Wt % is recommended.)

**Life Support Applications**

These NEC products are not intended for use in life support devices, appliances, or systems where the malfunction of these products can reasonably be expected to result in personal injury. The customers of CEL using or selling these products for use in such applications do so at their own risk and agree to fully indemnify CEL for all damages resulting from such improper use or sale.

EXCLUSIVE NORTH AMERICAN AGENT FOR **NEC** RF, MICROWAVE & OPTOELECTRONIC SEMICONDUCTORS

# Mouser Electronics

Authorized Distributor

Click to View Pricing, Inventory, Delivery & Lifecycle Information:

[CEL:](#)

[PS8701](#)