

# Ultra-Low Leakage Monolithic CMOS Analog Multiplexers

## ABSOLUTE MAXIMUM RATINGS

Voltage Referenced to V-

V+ .....	+44V
GND .....	+25V
Digital Inputs (Note 1), V <sub>S</sub> , V <sub>D</sub> .....	-2V to (V+ + 2V)
Current (Any Terminal, Except S or D) .....	30mA
Continuous Current, S or D (pulsed at 1ms, 10% duty cycle max) .....	40mA
Operating Temperature Range	
MAX328/329 C .....	0°C to +70°C
MAX328/329 E .....	-40°C to +85°C
MAX328/329 M .....	-55°C to +125°C

Power Dissipation (Package) (Note 1)

CERDIP (derate 10mW/°C above +70°C) .....	800mW
PDIP (derate 10.5mW/°C above +70°C) .....	842.1mW
Wide SO (derate 14.3mW/°C above +70°C) .....	1142.9mW
TQFN (derate 33.3mW/°C above +70°C) .....	2666.7mW
Storage Temperature .....	-65°C to +150°C
Lead Temperature (soldering, 10s) .....	+300°C
Soldering Temperature (reflow)	
Lead(Pb)-free packages (PDIP, TQFN, Wide SO) .....	+260°C
Packages containing lead(Pb) (CERDIP, PDIP, Wide SO) ..	+240°C
Packages containing lead(Pb) (TQFN) .....	+260°C

**Note 1:** All leads soldered or welded to PC board.

Stresses beyond those listed under "Absolute Maximum Ratings" may cause permanent damage to the device. These are stress ratings only, and functional operation of the device at these or any other conditions beyond those indicated in the operational sections of the specifications is not implied. Exposure to absolute maximum rating conditions for extended periods may affect device reliability.

## ELECTRICAL CHARACTERISTICS

(V<sub>+</sub> = 15V, V<sub>-</sub> = -15V, V<sub>GND</sub> = 0V, T<sub>A</sub> = +25°C, unless otherwise noted.) (Note 2)

PARAMETER	SYMBOL	CONDITIONS	MAX328M MAX329M			MAX328C/E MAX329C/E			UNITS
			MIN	TYP	MAX	MIN	TYP	MAX	
<b>SWITCH</b>									
Analog Signal Range	V <sub>ANALOG</sub>		-15		+15	-15		+15	V
Drain-Source On-Resistance	R <sub>DS(ON)</sub>	V <sub>D</sub> = 10V, I <sub>S</sub> = 100μA	Seq. each switch on, V <sub>AL</sub> = 0.8V, V <sub>AH</sub> = 2.4V		1.5	2.5	1.5	3.5	kΩ
		V <sub>D</sub> = -10V, I <sub>S</sub> = 100μA	1.0	2.5	1.0	3.5			
Greatest Change in Drain-Source On-Resistance Between Channels	ΔR <sub>DS(ON)</sub>	$R_{DS(ON)} = \frac{R_{DS(ON) \text{ Max}} - R_{DS(ON) \text{ Min}}}{R_{DS(ON) \text{ Ave}}}$			2		2		%
Source Off-Leakage Current (Note 3)	I <sub>S(OFF)</sub>	V <sub>S</sub> = 10V, V <sub>D</sub> = -10V	V <sub>EN</sub> = 0V	0.1	±10	0.1	±10	pA	
		V <sub>S</sub> = -10V, V <sub>D</sub> = 10V		0.3	±10	0.3	±10		
Drain Off-Leakage Current (Note 3)	MAX328	I <sub>D(OFF)</sub>	V <sub>EN</sub> = 0V	V <sub>D</sub> = 10V, V <sub>S</sub> = -10V	0.3	±10	0.3	±10	pA
				V <sub>D</sub> = -10V, V <sub>S</sub> = 10V	1.0	±10	1.0	±10	
	MAX329			V <sub>D</sub> = 10V, V <sub>S</sub> = -10V	0.3	±10	0.3	±10	
				V <sub>D</sub> = -10V, V <sub>S</sub> = 10V	0.5	±10	0.5	±10	
Drain On-Leakage Current (Note 3)	MAX328	I <sub>D(ON)</sub>	Seq. each switch on, V <sub>AL</sub> = 0.8V, V <sub>AH</sub> = 2.4V	V <sub>S</sub> (all) = V <sub>D</sub> = 10V	3.0	±10	3.0	±10	pA
				V <sub>S</sub> (all) = V <sub>D</sub> = -10V	2.0	±10	2.0	±10	
	MAX329			V <sub>S</sub> (all) = V <sub>D</sub> = 10V	1.5	±10	1.5	±10	
				V <sub>S</sub> (all) = V <sub>D</sub> = -10V	1.0	±10	1.0	±10	

# Ultra-Low Leakage Monolithic CMOS Analog Multiplexers

MAX328/MAX329

## ELECTRICAL CHARACTERISTICS (continued)

(V<sub>+</sub> = 15V, V<sub>-</sub> = -15V, V<sub>GND</sub> = 0V, T<sub>A</sub> = +25°C, unless otherwise noted.) (Note 2)

PARAMETER	SYMBOL	CONDITIONS		MAX328M MAX329M			MAX328C/E MAX329C/E			UNITS
				MIN	TYP	MAX	MIN	TYP	MAX	
<b>INPUT</b>										
Address Input Current, Input Voltage High	I <sub>AH</sub>	V <sub>A</sub> = 2.4V		0.001	±1		0.001	±1	μA	
		V <sub>A</sub> = 15V		0.001	±1		0.001	±1		
Address Input Current, Input Voltage Low	I <sub>AL</sub>	V <sub>EN</sub> = 2.4V	All	0.001	±1		0.001	±1	μA	
		V <sub>EN</sub> = 0V	V <sub>A</sub> = 0V	0.001	±1		0.001	±1		
<b>DYNAMIC</b>										
Switching Time of Multiplexer	t <sub>TRANSITION</sub>	Figure 1		1.0			1.5			μs
Break-Before-Make Interval	t <sub>OPEN</sub>	Figure 2		0.2			0.2			μs
Enable Turn-On Time	t <sub>ON(EN)</sub>	Figure 3		1.0			1.5			μs
Enable Turn-Off Time	t <sub>OFF(EN)</sub>	Figure 3		0.7			1.0			μs
Off-Isolation	OIRR	V <sub>EN</sub> = 0V, R <sub>L</sub> = 1kΩ, C <sub>L</sub> = 15pF, V <sub>S</sub> = 7V <sub>RMS</sub> , f = 500kHz		84			84			dB
Source Off-Capacitance	C <sub>S(OFF)</sub>	V <sub>S</sub> = 0V	V <sub>EN</sub> = 0V, f = 1MHz	1.8			1.8			pF
Drain Off- Capacitance	C <sub>D(OFF)</sub>	V <sub>D</sub> = 0V	V <sub>EN</sub> = 0V, f = 1MHz	8.0			8.0			pF
				4.0			4.0			
Charge Injection (Note 4)	Q <sub>(INJ)</sub>	V <sub>A</sub> = 10V		1			1			pC
		V <sub>A</sub> = 0V		2			5			
		V <sub>A</sub> = -10V		4			4			
<b>SUPPLY</b>										
Positive Supply Current	I <sub>+</sub>	V <sub>EN</sub> = 2.4V	V <sub>A</sub> = 0V/5V	4.5	200		4.5	200	μA	
Negative Supply Current	I <sub>-</sub>	V <sub>EN</sub> = 2.4V	V <sub>A</sub> = 0V/5V	1	-100		1	-100	μA	
Power-Supply Range for Continuous Operation (Note 7)	V <sub>OP</sub>			±5		±18	±5		±18	V

# Ultra-Low Leakage Monolithic CMOS Analog Multiplexers

## ELECTRICAL CHARACTERISTICS (Overtemperature)

( $V_+ = 15V$ ,  $V_- = -15V$ ,  $V_{GND} = 0V$ ,  $T_A = T_{MIN}$  to  $T_{MAX}$ , unless otherwise noted.) (Note 2)

PARAMETER	SYMBOL	TEST CONDITIONS	MAX328M MAX329M			MAX328C/E MAX329C/E			UNITS
			MIN	TYP	MAX	MIN	TYP	MAX	
<b>SWITCH</b>									
Analog-Signal Range	$V_{ANALOG}$		-15	+15	-15	+15			V
Drain-Source On-Resistance	$R_{DS(ON)}$	$V_D = 10V$ , $I_S = 100\mu A$	Seq. each switch on, $V_{AL} = 0.8V$ , $V_{AH} = 2.4V$		2.2	4	1.9	5	k $\Omega$
		$V_D = -10V$ , $I_S = 100\mu A$			1.5	4	1.2	5	
Source Off-Leakage Current (Note 6)	$I_{S(OFF)}$	$V_S = 10V$ , $V_D = -10V$	$V_{EN} = 0V$		$\pm 5$		$\pm 5$		nA
		$V_S = -10V$ , $V_D = 10V$			$\pm 5$		$\pm 5$		
Drain Off-Leakage Current (Note 6)	MAX328	$I_{D(OFF)}$	$V_{EN} = 0V$	$V_D = 10V$ , $V_S = -10V$	$\pm 20$		$\pm 20$		nA
				$V_D = -10V$ , $V_S = 10V$	$\pm 20$		$\pm 20$		
	MAX329			$V_D = 10V$ , $V_S = -10V$	$\pm 10$		$\pm 10$		
				$V_D = -10V$ , $V_S = 10V$	$\pm 10$		$\pm 10$		
Drain On-Leakage Current (Note 6)	MAX328	$I_{D(ON)}$	Seq. each switch on, $V_{AL} = 0.8V$ , $V_{AH} = 2.4V$	$V_S$ (all) = $V_D = 10V$	$\pm 20$		$\pm 20$		nA
				$V_S$ (all) = $V_D = -10V$	$\pm 20$		$\pm 20$		
	MAX329			$V_S$ (all) = $V_D = 10V$	$\pm 10$		$\pm 10$		
				$V_S$ (all) = $V_D = -10V$	$\pm 10$		$\pm 10$		
<b>INPUT</b>									
Address Input Current, Input Voltage High	$I_{AH}$	$V_A = 2.4V$			0.01	$\pm 1$	0.01	$\pm 1$	$\mu A$
		$V_A = 15V$			0.01	$\pm 1$	0.01	$\pm 1$	
Address Input Current, Input Voltage Low	$I_{AL}$	$V_{EN} = 2.4V$	All $V_A = 0V$		0.01	$\pm 1$	0.01	$\pm 1$	$\mu A$
		$V_{EN} = 0V$			0.01	$\pm 1$	0.01	$\pm 1$	

**Note 2:** Typical values are for design aid only; not guaranteed or subject to production testing.

**Note 3:** All leakage parameters are 100% tested at maximum rated operating temperature, i.e., +70°C, +85°C, +125°C, and guaranteed by correlation at +25°C.

**Note 4:** Guaranteed by design.

**Note 5:** Electrical characteristics, such as On-Resistance, change when power supplies other than  $\pm 15V$  are used. Power-supply range is a design characteristic, not production tested.

**Note 6:** Leakage parameters are 100% tested at maximum rated operating temperature, i.e., +70°C, etc.

# Ultra-Low Leakage Monolithic CMOS Analog Multiplexers

## Typical Operating Characteristics

( $T_A = +25^\circ\text{C}$ , unless otherwise noted.)

MAX328/MAX329

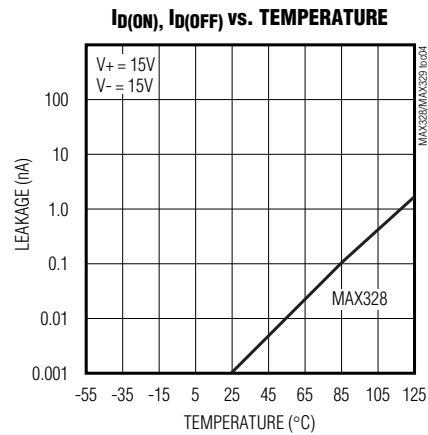
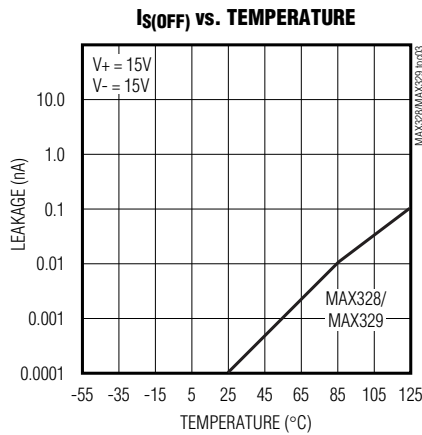
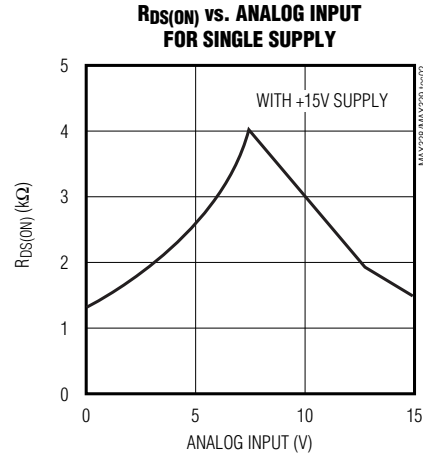
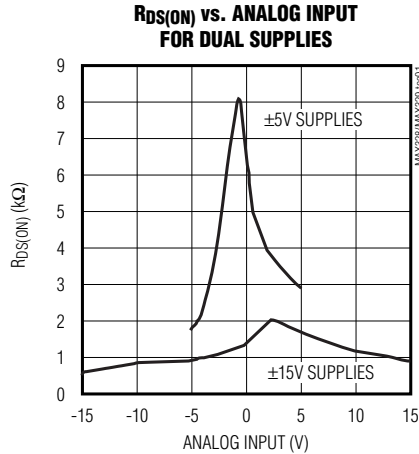

# Ultra-Low Leakage Monolithic CMOS Analog Multiplexers

## Pin Description

PIN				NAME	FUNCTION
MAX328		MAX329			
DIP/SO	TQFN-EP	DIP/SO	TQFN-EP		
1, 15, 16	15, 14, 13	—	—	A0, A2, A1	Address Input
—	—	1, 16	15, 14	A0, A1	Address Input
2	16	2	16	EN	Enable
3	1	3	1	V-	Negative-Supply Voltage Input
4–7	2–5	—	—	S1–S4	Analog Inputs—Bidirectional
—	—	4–7	2–5	S1A–S4A	Analog Inputs—Bidirectional
8	6	—	—	D	Analog Outputs—Bidirectional
—	—	8, 9	6, 7	DA, DB	Analog Outputs—Bidirectional
9–12	7–10	—	—	S8–S5	Analog Inputs—Bidirectional
—	—	10–13	8–11	S4B–S1B	Analog Inputs—Bidirectional
13	11	14	12	V+	Positive-Supply Voltage Input
14	12	15	13	GND	Ground
—	—	—	—	EP	Exposed pad. Connect EP to V+. (TQFN only).

Truth Table—MAX328

A2	A1	A0	EN	ON SWITCH
X	X	X	0	None
0	0	0	1	1
0	0	1	1	2
0	1	0	1	3
0	1	1	1	4
1	0	0	1	5
1	0	1	1	6
1	1	0	1	7
1	1	1	1	8

Truth Table—MAX329

A1	A0	EN	ON SWITCH
X	X	0	None
0	0	1	1
0	1	1	2
1	0	1	3
1	1	1	4

**Note:** Logic “0” =  $V_{AL} \leq 0.8V$ , Logic “1” =  $V_{AH} \geq 2.4V$

# Ultra-Low Leakage Monolithic CMOS Analog Multiplexers

MAX328/MAX329

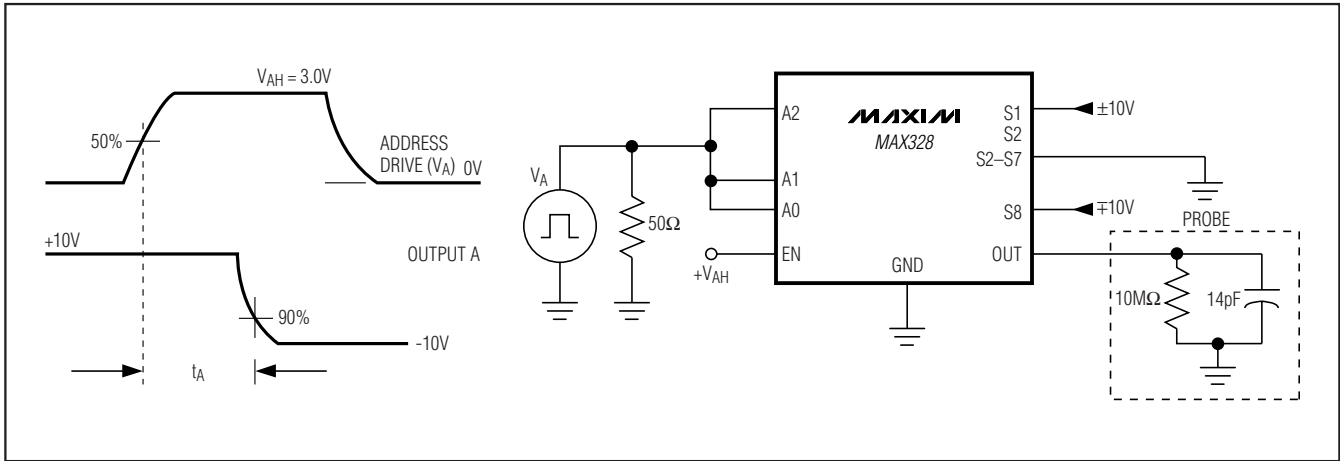

Figure 1. Access Time vs. Logic Level (High)

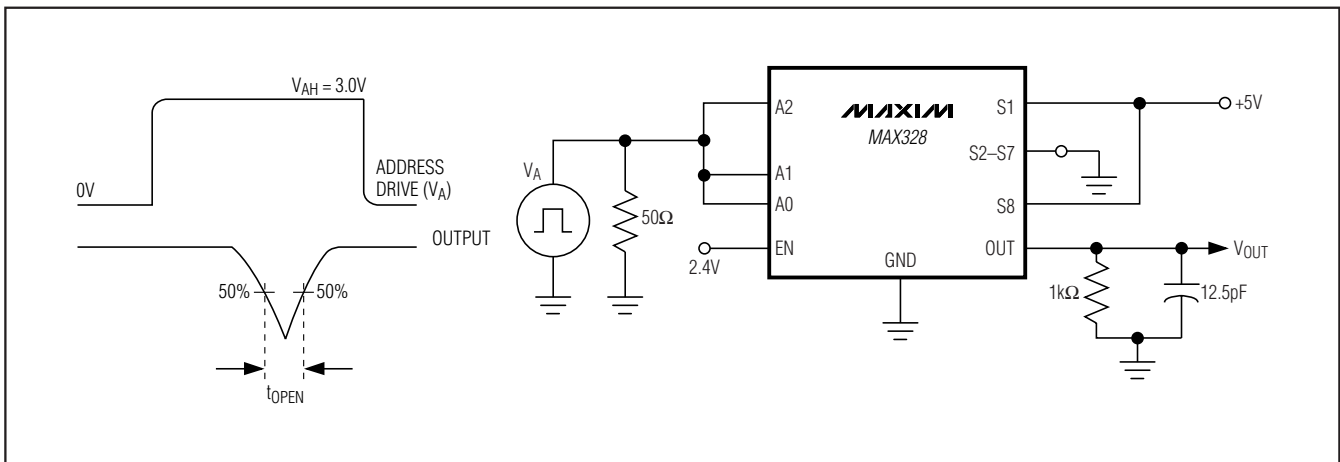

Figure 2. Break-Before-Make Delay ( $t_{OPEN}$ )

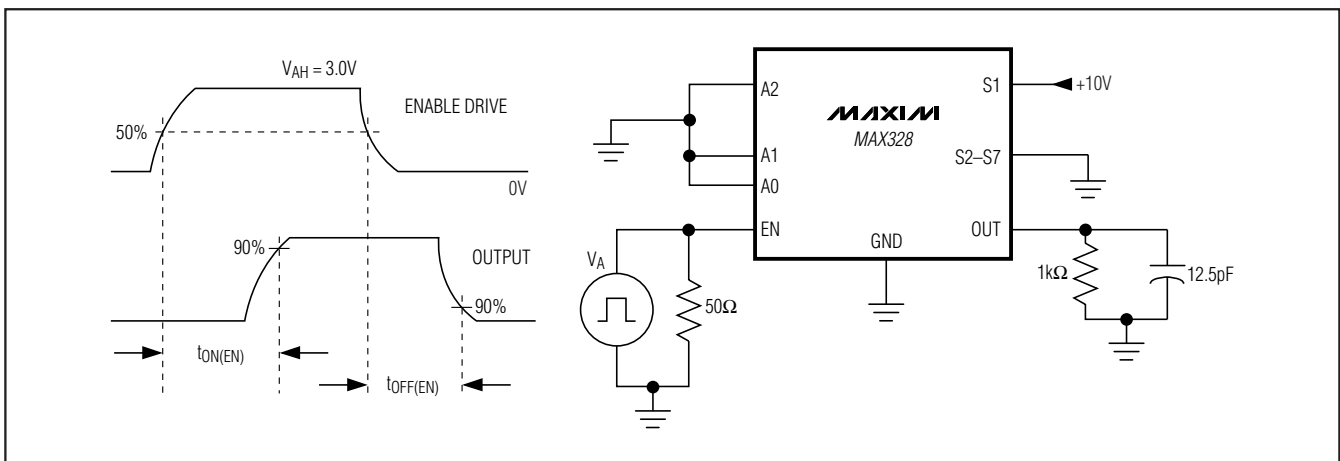

Figure 3. Enable Delay ( $t_{ON(EN)}$ ,  $t_{OFF(EN)}$ )

# Ultra-Low Leakage Monolithic CMOS Analog Multiplexers

## Applications Information

Figure 4 is a typical circuit for converting the MAX328/MAX329 into a fault-tolerant mux. In this application, the internal diodes limit the voltage at the MAX328 input to  $\pm 15.7V$  ( $\pm 15V$  supplies). No external diodes need to be added with the MAX328/MAX329, unlike conventional multiplexers requiring external diodes.

The resistors, R, need to be  $39k\Omega$  or higher to limit the power dissipation in the resistor when a 120V AC fault occurs (i.e., power dissipation is  $(120-16)^2/39k\Omega$  or 0.28W. This is why a 1/2W resistor is needed). The circuit withstands an indefinite fault to a 120V AC line with no damage to any component.

In addition to allowing fault-protection, the guaranteed low leakage of the MAX328/MAX329 also reduces signal errors. The circuit in Figure 4 produces an error voltage of  $10pA$  (max leakage)  $\times 39k\Omega$  or  $0.39\mu V$  at room temperature and  $39\mu V$  at  $+125^\circ C$ . Therefore, for 10V signals, the MAX328/MAX329 allows 17-bit resolution ( $38\mu V = 1LSB$ ) over the full temperature range.

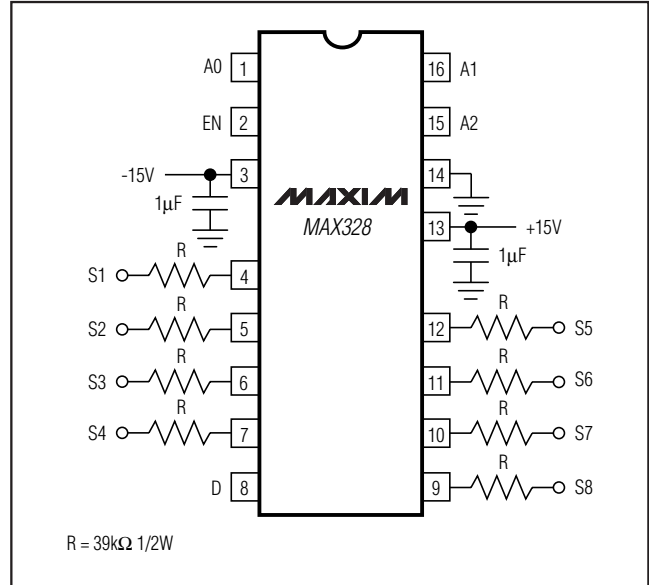
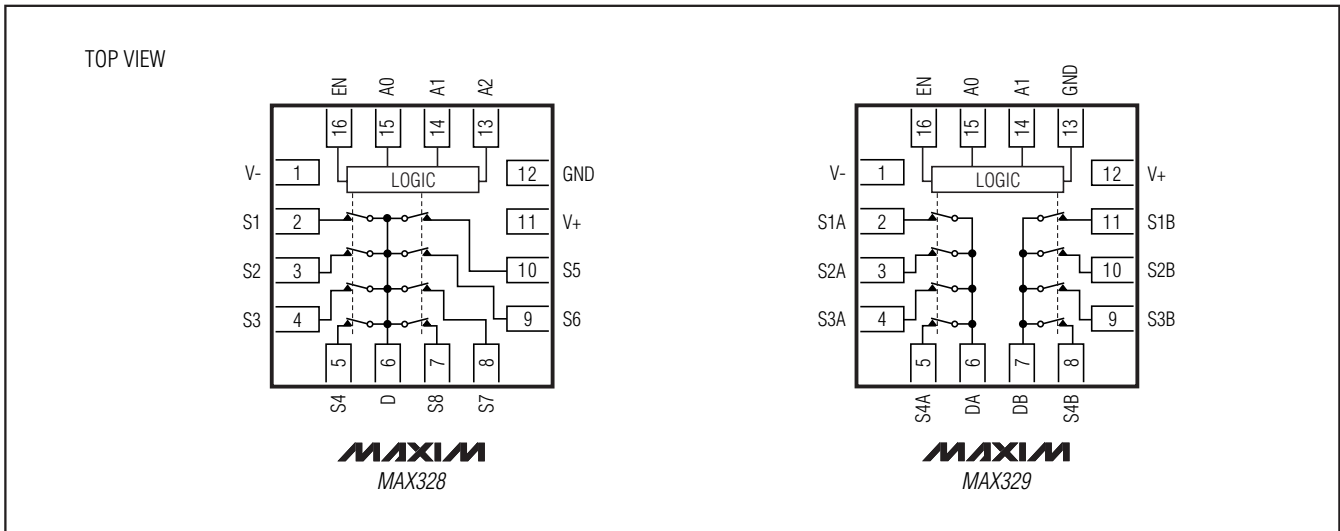

Figure 4. Fault-Tolerant Mux (indefinitely withstands 120V AC fault voltages)

## Functional Diagrams



# Ultra-Low Leakage Monolithic CMOS Analog Multiplexers

**MAX328/MAX329**

## Ordering Information (continued)

PART	TEMP RANGE	PIN-PACKAGE
MAX329CPE+	0°C to +70°C	16 Plastic DIP
MAX329CWE+	0°C to +70°C	16 Wide SO
MAX329CJE	0°C to +70°C	16 CERDIP
MAX329C/D	0°C to +70°C	Dice*
MAX329ETE+	-40°C to +85°C	16 TQFN-EP**
MAX329EPE+	-40°C to +85°C	16 Plastic DIP
MAX329EWE+	-40°C to +85°C	16 Wide SO
MAX329EJE	-40°C to +85°C	16 CERDIP***
MAX329MJE	-55°C to +125°C	16 CERDIP***

+ Denotes a lead(Pb)-free/RoHS-compliant package.

\* Contact factory for dice specifications.

\*\* EP = Exposed pad.

\*\*\* Contact factory for availability. Substrate may be allowed to be unconnected or be connected to V+.

## Package Information

For the latest package outline information and land patterns (footprints), go to [www.maxim-ic.com/packages](http://www.maxim-ic.com/packages). Note that a "+", "#", or "-" in the package code indicates RoHS status only. Package drawings may show a different suffix character, but the drawing pertains to the package regardless of RoHS status.

PACKAGE TYPE	PACKAGE CODE	OUTLINE NO.	LAND PATTERN NO.
16 CERDIP	J16+3	<a href="#">21-0045</a>	—
16 PDIP	P16+2	<a href="#">21-0043</a>	—
16 TQFN-EP	T1655+3	<a href="#">21-0140</a>	<a href="#">90-0073</a>
16 Wide SO	W16+2	<a href="#">21-0042</a>	<a href="#">90-0107</a>

## Pin Configurations (continued)

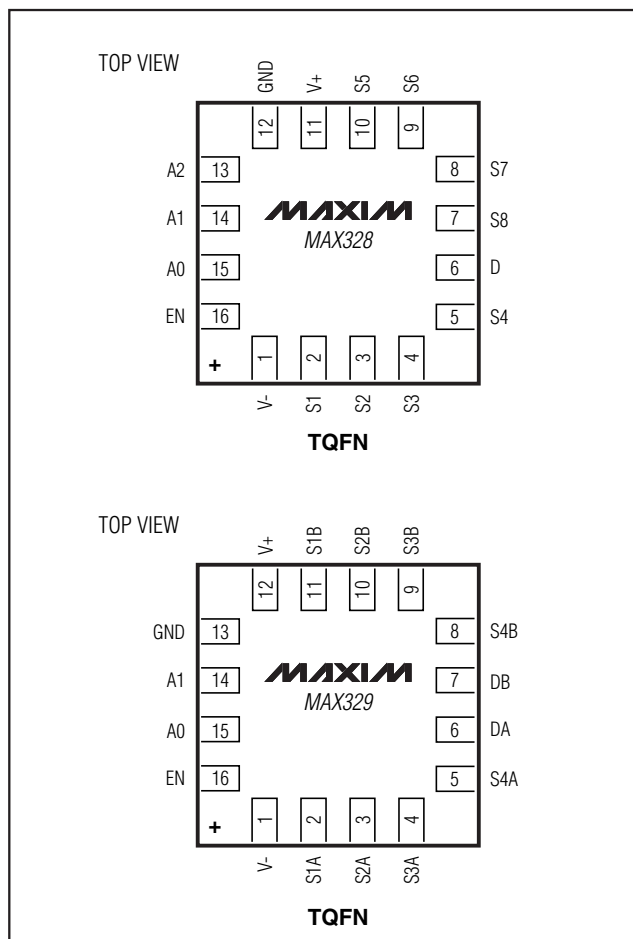



# Ultra-Low Leakage Monolithic CMOS Analog Multiplexers

## Revision History

REVISION NUMBER	REVISION DATE	DESCRIPTION	PAGES CHANGED
3	2/11	Updated the <i>Ordering Information</i> table to reflect lead-free parts and corrected part numbers and package types	1, 9

Maxim cannot assume responsibility for use of any circuitry other than circuitry entirely embodied in a Maxim product. No circuit patent licenses are implied. Maxim reserves the right to change the circuitry and specifications without notice at any time.

10 **Maxim Integrated Products, 120 San Gabriel Drive, Sunnyvale, CA 94086 408-737-7600**

# Mouser Electronics

Authorized Distributor

Click to View Pricing, Inventory, Delivery & Lifecycle Information:

## Maxim Integrated:

[MAX328CPE+](#) [MAX328CWE+](#) [MAX328EWE+](#) [MAX329CPE+](#) [MAX329CWE+](#) [MAX328CWE+T](#) [MAX328EPE+](#)  
[MAX328ETE+](#) [MAX328ETE+T](#) [MAX328EWE+T](#) [MAX329CWE+T](#) [MAX329EPE+](#) [MAX329EWE+](#) [MAX329EWE+T](#)  
[MAX328MWE/PR3+](#) [MAX328MWE/PR3+T](#) [MAX329MWE/PR3+](#) [MAX329MWE/PR3+T](#)