

### Maximum Ratings

(Absolute maximum ratings over operating free-air temperature range from  $V_{CCB}$  at 3.3V &  $V_{CCA}$  at 1.5 - 2.5V (unless otherwise noted)

Supply voltage range:	$V_{CCA}$ .....	-0.5V to 3.6V
	$V_{CCB}$ .....	-0.5V to 3.6V
Input Voltage Range, $V_I$	Except I/O ports <sup>(1)</sup> .....	-0.5V to 3.6V
	I/O port A <sup>(2)</sup> .....	-0.5V to $V_{CCA}+0.1V$
	I/O port B <sup>(1)</sup> .....	-0.5V to $V_{CCB}+0.1V$
Input clamp current, $I_{IK}$ ( $V_I < 0$ ) .....		-25mA
Output clamp current, $I_{OK}$ ( $V_O < 0$ ) .....		-25mA
Continuous output current, $I_O$ .....		$\pm 25mA$
Continuous current through each $V_{CC}$ or GND .....		$\pm 50mA$
Package thermal impedance, $\theta_{JA}$ <sup>(3)</sup> : A package .....		55°C/W
Storage temperature range, $T_{STG}$ .....		-65°C to 150°C

#### Notes:

Stresses greater than those listed under MAXIMUM RATINGS may cause permanent damage to the device. This is a stress rating only and functional operation of the device at these or any other conditions above those indicated in the operational sections of this specification is not implied. Exposure to absolute maximum rating conditions for extended periods may affect reliability.

1. This value is limited to 3.6V maximum.
2. This value is limited to 2.7V maximum.
3. The package thermal impedance is calculated in accordance with JESD 51.

### Recommended Operating Conditions for $V_{CCB}$ at 3.3V<sup>(1)</sup>

		Min.	Max.	Units
$V_{CCB}$	Supply voltage	3.0	3.6	V
$V_{IH}$	High-level voltage	2		
$V_{IL}$	Low-level voltage		0.8	
$V_{IA}$	Input Voltage	0	$V_{CCB}$	
$V_{OB}$	Output Voltage	0	$V_{CCB}$	
$I_{OH}$	High-level output current		-12	mA
$I_{OL}$	Low-level output current		12	
$T_A$	Operating free-air temperature	-40	85	°C

### Recommended Operating Conditions for $V_{CCA}$ at 1.8V<sup>(1)</sup>

		Min.	Nom.	Max.	Units	
$V_{CCA}$	Supply Voltage	1.7	1.8	1.9	V	
$V_{REF}$	Reference Voltage	0.85	0.9	0.95	V	
$V_{IN}$	Input Voltage	0		1.9	V	
$V_{IH}$	AC High-Level Input Voltage	All Inputs	$V_{REF} + 200mV$		V	
$V_{IL}$	AC Low-Level Input Voltage			$V_{REF} - 200mV$	V	
$V_{IH}$	DC High-Level Input Voltage		$V_{REF} + 100mV$		$V_{CCA} + 300mV$	V
$V_{IL}$	DC Low-Level Input Voltage		-500mV		$V_{REF} - 100mV$	V
$I_{OH}$	High-Level Output Current			-8	mA	
$I_{OL}$	Low-Level Output Current			8	mA	
$T_A$	Operating Free-Air Temperature	-40		85	°C	

#### Notes:

1. To ensure proper device operation, all unused device inputs must be held at the associated  $V_{CC}$  or GND.

### Electrical Characteristics, $V_{CCA}$

Over recommended operating free-air temperature range for  $V_{CCA} = 1.8V \pm 100mV$

Parameters		Test Conditions	$V_{CCA}$	Min.	Typ. <sup>(1)</sup>	Max.	Units
$V_{OH}$		$I_{OH} = -8mA$	1.7	$V_{CCA} - 0.4$			V
$V_{OL}$		$I_{OH} = 8mA$	1.7			0.4	
$I_{DD}$		$V_{IN} = 0$ or $V_{CCA}$	1.9			TBD	
$I_I$	Data Inputs	$V_{IN} = 0$ or $V_{CCA}$	1.9			$\pm 5$	$\mu A$
	$V_{REF}$	$V_{REF} = 0.95V$	1.9			90	
$C_O$	Outputs	$V_O = 0$	0		6.0		pF

**Notes:**

1. Typical values at  $V_{CCA} 1.8V$  and  $T_A = 25^\circ C$

### Electrical Characteristics, $V_{CCB}$

Over recommended operating free-air temperature range for  $V_{CCB} = 3.3V \pm 300mV$

Parameters		Test Conditions	$V_{CCB}$	Min.	Typ. <sup>(1)</sup>	Max.	Units
$V_{IK}$		$I_I = -18mA$	3.0			-1.2	V
$V_{OH}$		$I_{OH} = -12mA$	3.0	2.4			
$V_{OL}$		$I_{OH} = 12mA$	3.0			0.5	
$I_{DD}$		$V_{IN} = 0$ or $V_{CCB}$	3.6			TBD	
$I_I$	Control Inputs	$V_{IN} = 0$ or $V_{CCB}$	3.6			$\pm 5$	$\mu A$
	Data Inputs	$V_{IN} = 0$ or $V_{CCB}$	3.6			$\pm 5$	
$C_I$	Control Inputs	$V_{IN} = 0$ or $3.3V$	3.3		4.4		pF
$C_O$	Outputs	$V_O = 0$	0		6.0		

**Notes:**

1. Typical values at  $V_{CCB} 3.3V$  and  $T_A = 25^\circ C$

### Switching Characteristics

Over recommended operating free-air temperature range (see Figures 1, 2, & 3)

Parameter	From (Input)	To (Output)	$V_{CCA} = 1.8V \pm 0.1V$		$V_{CCB} = 3.3V \pm 0.3V$		Units
			Min.	Max.	Max.		
$t_{pD}$	A	B	1.0		3.0		ns
	B	A	1.0		3.0		
$t_{sk(o)}^{(1)}$					0.35		

**Notes:**

1. This is the skew between any two outputs in the same 12-bit bank of the same package switching in any direction on the same port. This is guaranteed by design, this is not a production test.

**Parameter Measurement Information - B to A Direction**

$V_{CCB} = 3.3V \pm 0.3V$  and  $V_{CCA} = 1.8V \pm 0.10V$

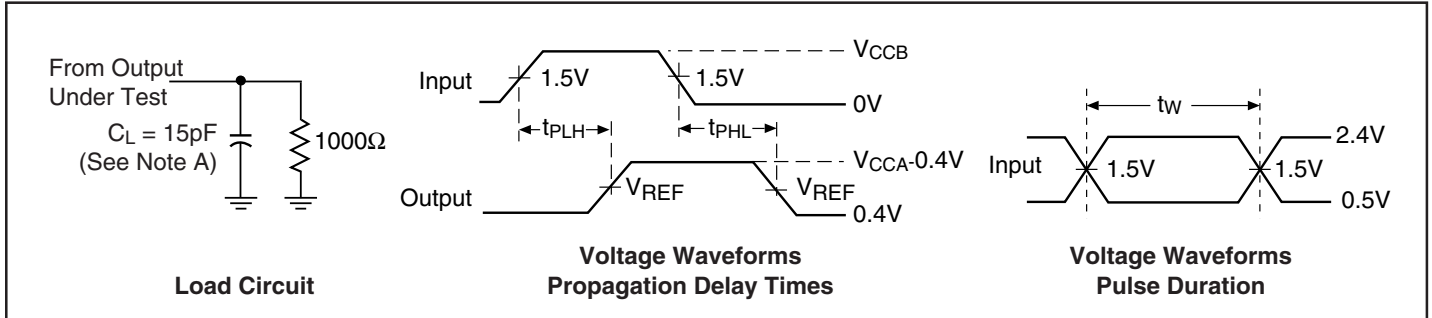

Figure 1. Load Circuit and Voltage Waveforms

**Parameter Measurement Information - A to B Direction**

$V_{CCA} = 1.8V \pm 0.10V$  and  $V_{CCB} = 3.3V \pm 0.3V$

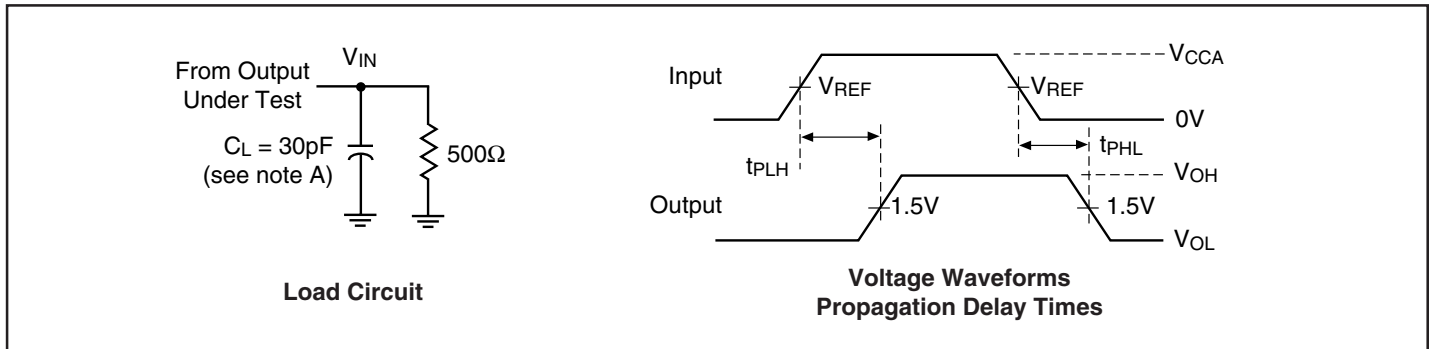

Figure 2. Load Circuit and Voltage Waveforms

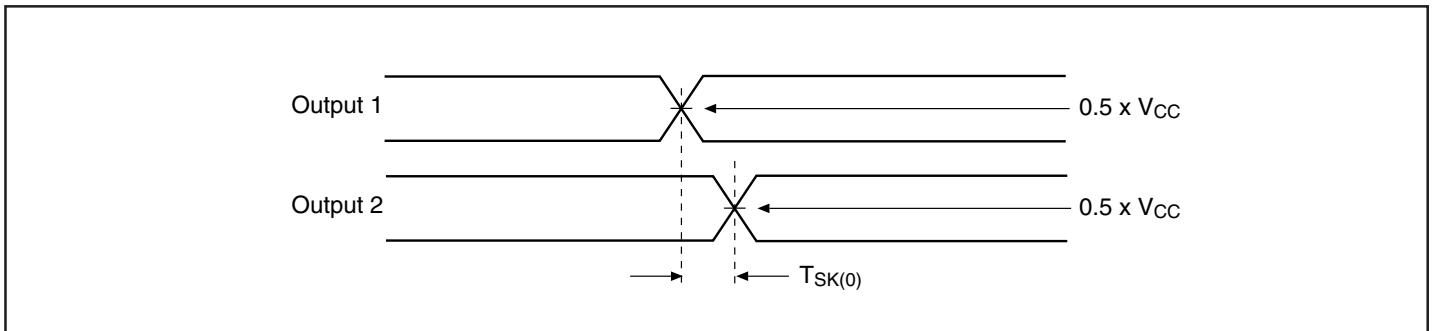
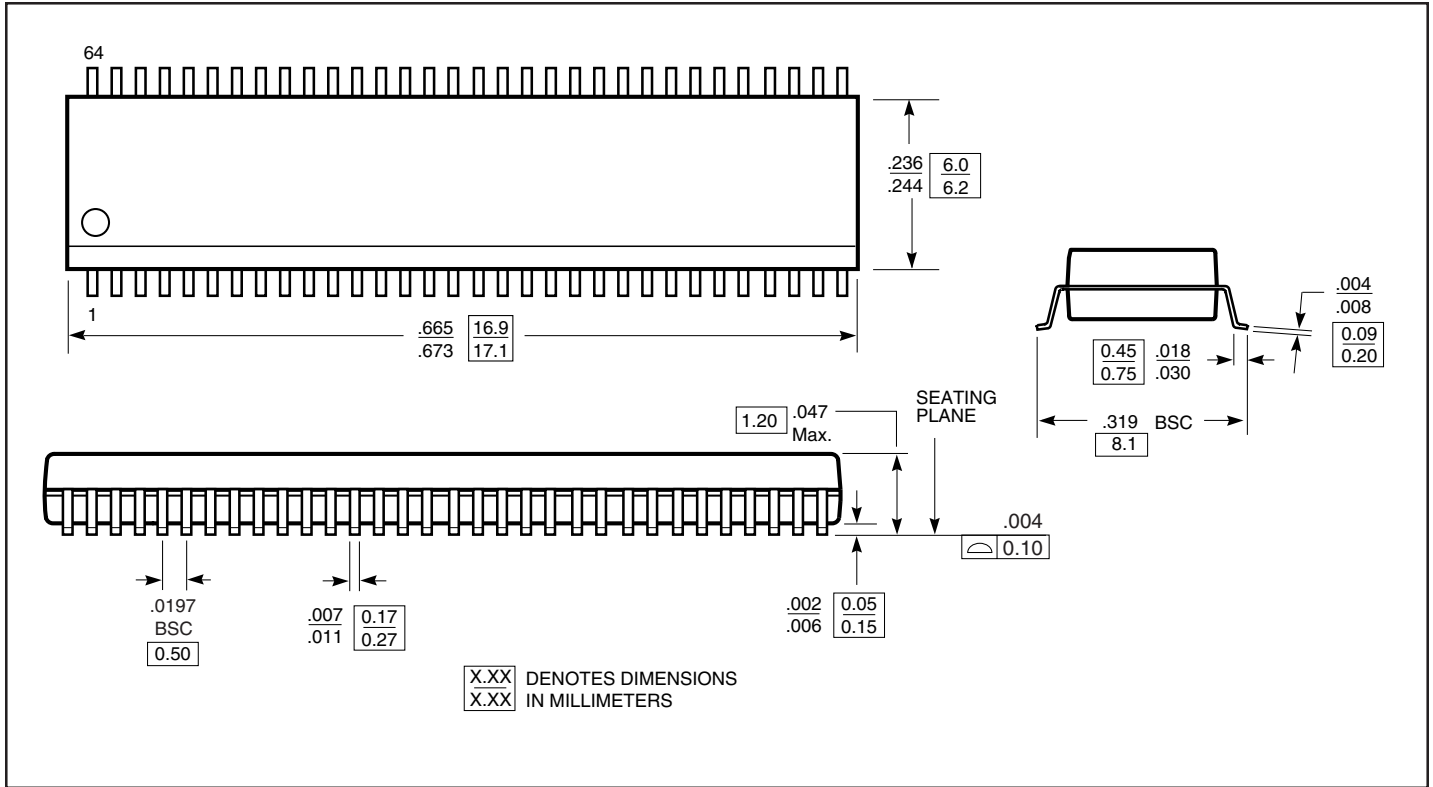

Figure 3. Opposite Edge Skew

**Notes:**

- A.  $C_L$  includes probe and jig capacitance.
- Waveform 1 is for an output with internal conditions such that the output is low except when disabled by the output control. Waveform 2 is for an output with internal conditions such that the output is high except when disabled by the output control.
- All input pulses are supplied by generators having the following characteristics:  $PRR \leq 10Mz$ ,  $Z_O = 50\text{-ohm}$ ,  $t_r \leq 2.5ns$ ,  $t_f \leq 2.5ns$ .
- The outputs are measured one at a time with one transition per measurement.
- $t_{PLZ}$  and  $t_{PHZ}$  are the same as  $t_{DIS}$ .
- $t_{PZL}$  and  $t_{PZH}$  are the same as  $t_{EN}$ .
- $t_{PLH}$  and  $t_{PHL}$  are the same as  $t_{PD}$ .

**Packaging Mechanical: 64-pin TSSOP (A)**



**Ordering Information**

Ordering Code	Package Type	Package Description
PI74HSTL1212A	A	64-pin, 240 mil wide plastic TSSOP
PI74HSTL1212AE	A	Pb-free & Green, 64-pin, 240 mil wide plastic TSSOP

**Notes:**

- Thermal characteristics can be found on the company web site at [www.pericom.com/packaging/](http://www.pericom.com/packaging/)
- E = Pb-free & Green
- Adding an X suffix = Tape/Reel

# Mouser Electronics

Authorized Distributor

Click to View Pricing, Inventory, Delivery & Lifecycle Information:

[Diodes Incorporated:](#)

[PI74HSTL1212AEX](#) [PI74HSTL1212AE](#)