

Low-Voltage Analog Temperature Sensors in SC70 and SOT23 Packages

ABSOLUTE MAXIMUM RATINGS

V_{CC} to GND-0.3V to +6V
 OUT, A to GND-0.3V to (V_{CC} + 0.3V)
 ESD Protection (Human Body Model)>2000V
 Current into Any Pin10mA
 Output Short-Circuit DurationContinuous
 Continuous Power Dissipation (T_A = +70°C)
 5-Pin SC70 (derate 3.1mW/°C above +70°C)245mW
 5-Pin SOT23 (derate 7.1mW/°C above +70°C)571mW

Operating Temperature Range-55°C to +125°C
 Junction Temperature+150°C
 Storage Temperature Range-65°C to +150°C
 Lead Temperature (soldering, 10s)+300°C

Stresses beyond those listed under "Absolute Maximum Ratings" may cause permanent damage to the device. These are stress ratings only, and functional operation of the device at these or any other conditions beyond those indicated in the operational sections of the specifications is not implied. Exposure to absolute maximum rating conditions for extended periods may affect device reliability.

ELECTRICAL CHARACTERISTICS

(V_{CC} = +1.8V to +3.6V, C_L = 1nF, T_A = -20°C to +85°C, typical values are at T_A = +25°C, unless otherwise noted.) (Note 1)

PARAMETER	SYMBOL	CONDITIONS	MIN	TYP	MAX	UNITS	
Temperature Error		V _{CC} = +2.4V	T _A = +20°C to +50°C	-2.0	0.6	+2.0	°C
			T _A = 0°C to +70°C	-3.5	0.7	+3.5	
			T _A = -10°C to +85°C	-5.0	1.0	+5.0	
			T _A = -20°C to -10°C	-6.0	1.5	+6.0	
Supply Voltage	V _{CC}		1.8		3.6	V	
Maximum Rate of Rise of Supply Voltage (Note 2)		V _{CC} < 2.8V	T _A = +70°C		1000	V/s	
			T _A = +80°C		500		
			T _A = +85°C		100		
Supply Current	I _Q	No load		8	15	μA	
Output Voltage	V _{OUT}	T _A = 0°C		500		mV	
Sensor Gain (Average Slope)				10		mV/°C	
Maximum Capacitive Load				1		nF	
Load Regulation		I _{OUT} = -1.2μA to +20μA		0.15	0.2	°C/μA	
Line Regulation				0.3	0.9	°C/V	

Note 1: All parameters are measured at T_A = +25°C. Specifications over temperature range are guaranteed by design.

Note 2: Not production tested, guaranteed by design.

Low-Voltage Analog Temperature Sensors in SC70 and SOT23 Packages

Typical Operating Characteristics

($V_{CC} = +1.8V$, $C_S = 0.1\mu F$, $C_L = 1nF$, unless otherwise noted.)

MAX6607/MAX6608

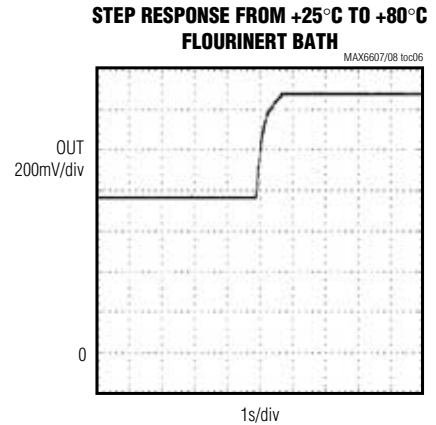
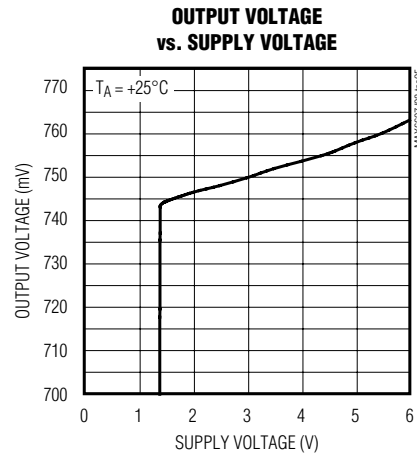
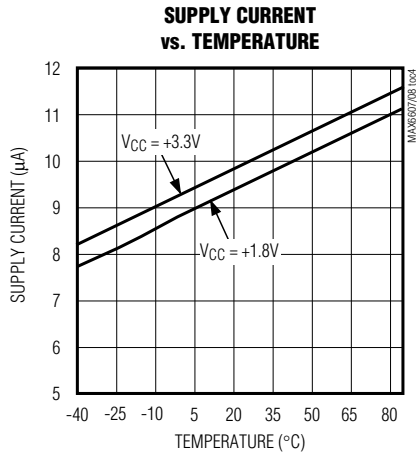
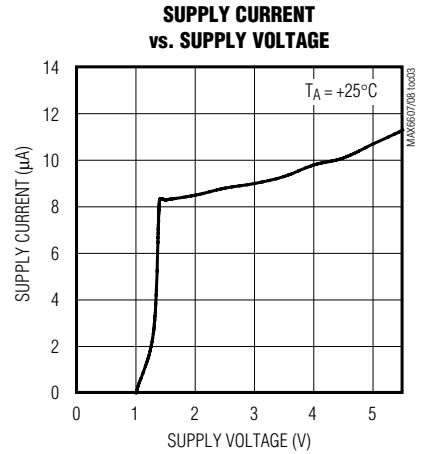
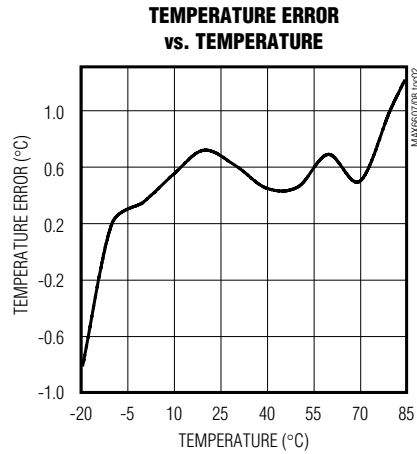
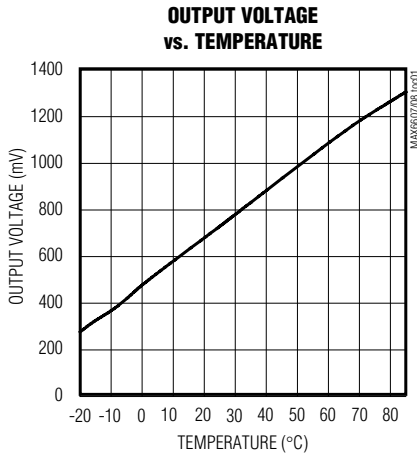

Low-Voltage Analog Temperature Sensors in SC70 and SOT23 Packages

Pin Description

PIN		NAME	FUNCTION
SC70	SOT23		
1	5	OUT	Temperature Sensor Output
2	1	N.C.	Not Connected
3	3	A	Must be connected to GND.
4	4	V _{CC}	Supply Input. Decouple with a 0.1μF capacitor to GND.
5	2	GND	Ground

Detailed Description

The MAX6607/MAX6608 analog output temperature sensors' output voltage is a linear function of its die temperature. The slope of the output voltage is 10mV/°C, and there is a 500mV offset at 0°C to allow measurement of negative temperatures. The maximum supply current is 15μA, and the supply voltage range is from +1.8V to +3.6V for the -20°C to +85°C temperature range.

Transfer Function

The temperature-to-voltage transfer function has an approximately linear positive slope and can be described by the equation:

$$V_{OUT} = 500\text{mV} + (T \times 10\text{mV}/^{\circ}\text{C})$$

where T is the die temperature of the MAX6607/MAX6608 in °C.

Therefore:

$$T (^{\circ}\text{C}) = (V_{OUT} - 500\text{mV}) / 10\text{mV}/^{\circ}\text{C}$$

Applications Information

Sensing Circuit Board and Ambient Temperatures

Temperature sensor ICs like the MAX6607/MAX6608 that sense their own die temperatures must be mounted on, or close to, the object whose temperature they are intended to measure. Because there is a good thermal path between the package's metal leads and the IC die, the MAX6607/MAX6608 can accurately measure the temperature of the circuit board to which it is soldered. If the sensor is intended to measure the temperature of a heat-generating component on the circuit board, it should be mounted as close as possible to that component and should share supply and ground traces (if they are not noisy) with that component where possible. This maximizes the heat transfer from the component to the sensor.

The thermal path between the plastic package and the die is not as good as the path through the leads, so the MAX6607/MAX6608, like all temperature sensors in plastic packages, are less sensitive to the temperature of the surrounding air than they are to the temperature of their leads. They can be successfully used to sense ambient temperature if the circuit board is designed to track the ambient temperature.

As with any IC, the wiring and circuits must be kept insulated and dry to avoid leakage and corrosion, especially if the part is operated at cold temperatures where condensation can occur.

The error introduced by the part self-heating is negligible.

Chip Information

TRANSISTOR COUNT: 111

PROCESS: BiCMOS

Low-Voltage Analog Temperature Sensors in SC70 and SOT23 Packages

Package Information

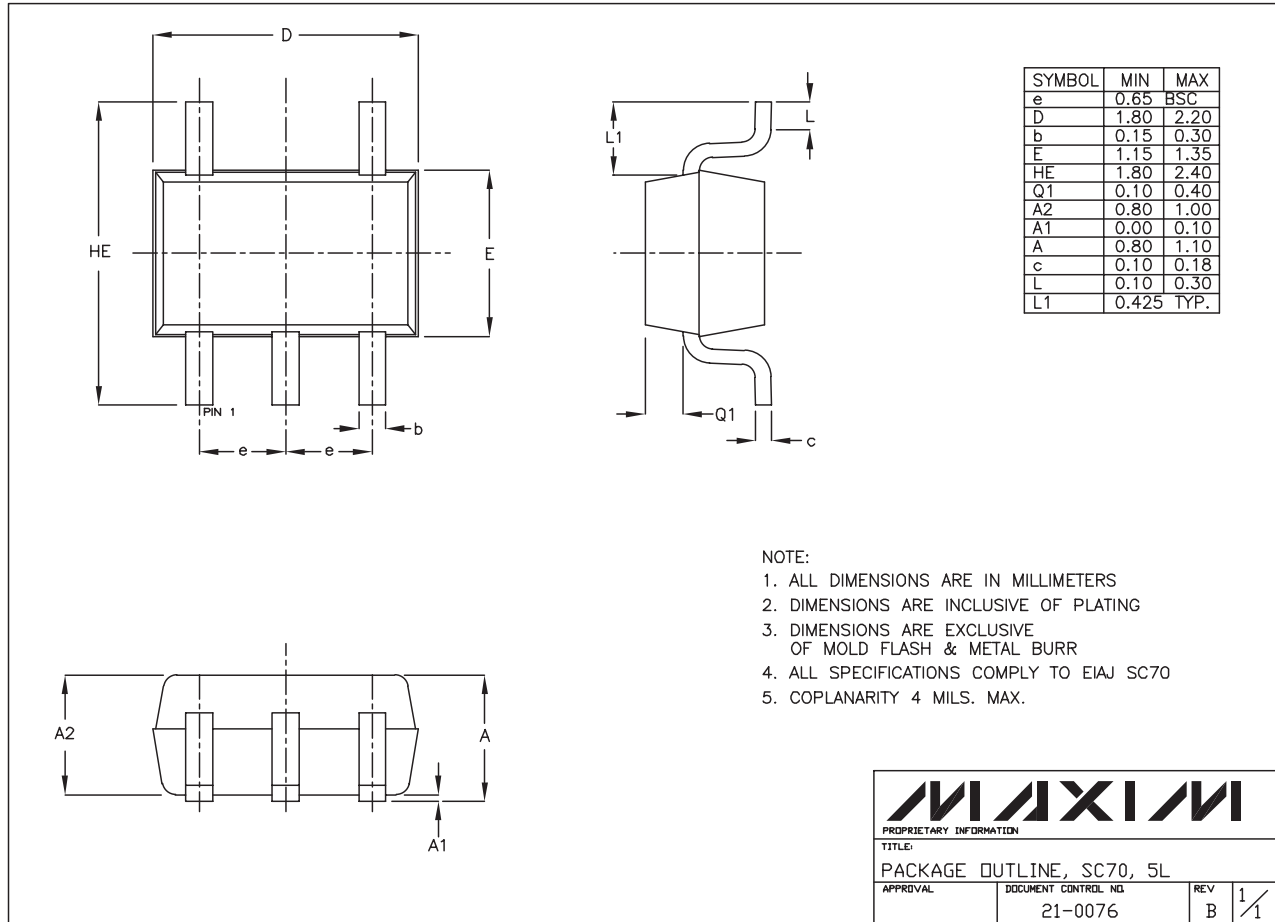

SC70, 5LEPS

MAX6607/MAX6608

Low-Voltage Analog Temperature Sensors in SC70 and SOT23 Packages

Package Information (continued)

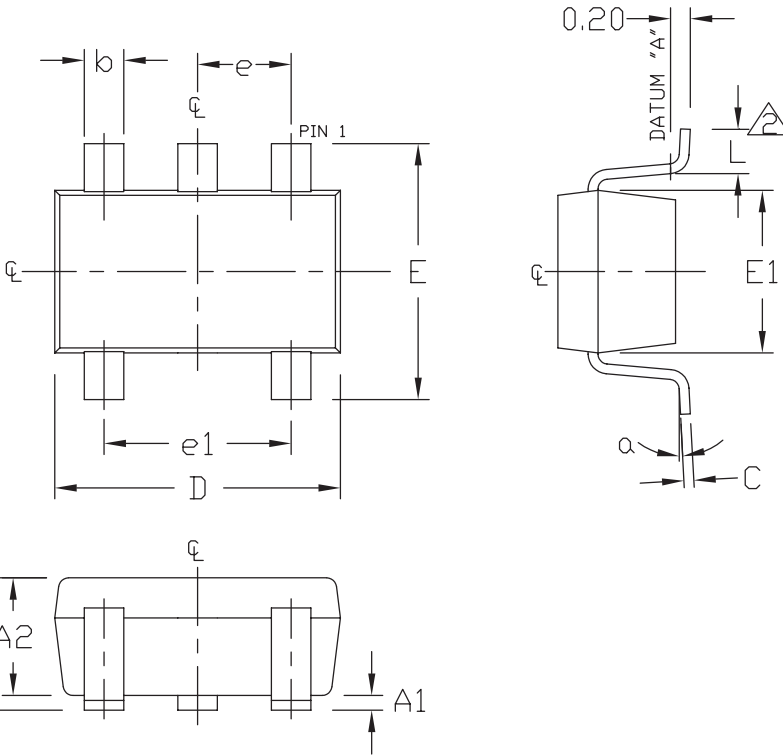

SYMBOL	MIN	MAX
A	0.90	1.45
A1	0.00	0.15
A2	0.90	1.30
b	0.35	0.50
C	0.08	0.20
D	2.80	3.00
E	2.60	3.00
E1	1.50	1.75
L	0.35	0.55
e	0.95	REF
e1	1.90	REF
α	0°	10°

NOTES:

1. ALL DIMENSIONS ARE IN MILLIMETERS.
2. FOOT LENGTH MEASURED AT INTERCEPT POINT BETWEEN DATUM A & LEAD SURFACE.
3. PACKAGE OUTLINE EXCLUSIVE OF MOLD FLASH & METAL BURR.
4. PACKAGE OUTLINE INCLUSIVE OF SOLDER PLATING.
5. MEETS JEDEC MO178.

MAXIM			
<small>PROPRIETARY INFORMATION</small>			
<small>TITLE:</small>			
PACKAGE OUTLINE, SOT-23, 5L			
<small>APPROVAL</small>	<small>DOCUMENT CONTROL NO.</small>	<small>REV</small>	<small>1/1</small>
	21-0057	C	

Maxim cannot assume responsibility for use of any circuitry other than circuitry entirely embodied in a Maxim product. No circuit patent licenses are implied. Maxim reserves the right to change the circuitry and specifications without notice at any time.

6 Maxim Integrated Products, 120 San Gabriel Drive, Sunnyvale, CA 94086 408-737-7600

Mouser Electronics

Authorized Distributor

Click to View Pricing, Inventory, Delivery & Lifecycle Information:

[Maxim Integrated:](#)

[MAX6607IXK+T](#) [MAX6608IUK+T](#)