

Jan.1.2022 Copyright 2022 HIROSE ELECTRIC CO., LTD. All Rights Reserved.
In case of consideration for using Automotive equipment / device which demand high reliability, kindly contact our sales window correspondents.

6 RECOMMENDED PCB LAYOUT

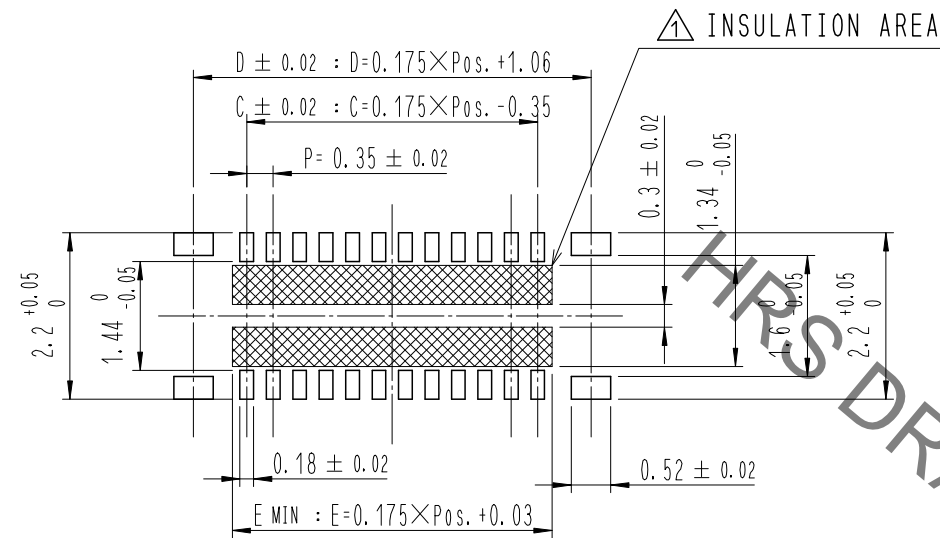

RECOMMENDED METAL MASK DIMENSIONS

MATAL MASK THICKNESS : 100 μm

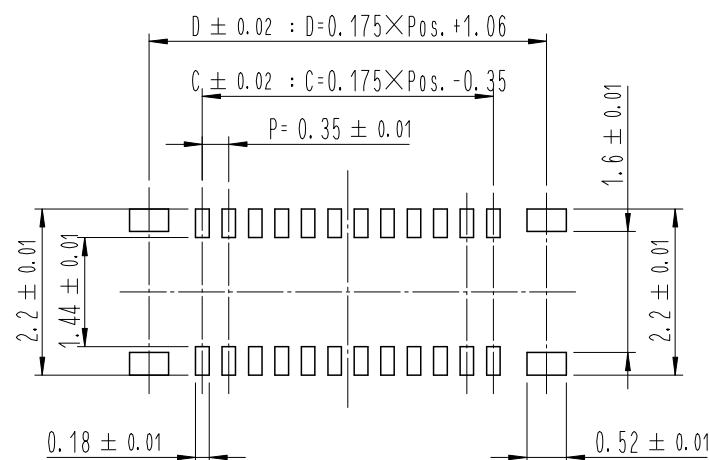

TABLE

POS.	C	D	E
6	0.70	2.11	1.08
8	1.05	2.46	1.43
10	1.40	2.81	1.78
12	1.75	3.16	2.13
16	2.45	3.86	2.83
20	3.15	4.56	3.53
24	3.85	5.26	4.23
30	4.90	6.31	5.28
34	5.60	7.01	5.98
40	6.65	8.06	7.03
50	8.40	9.81	8.78

5 RECOMMENDED REFLOW TEMPERATURE PROFILE USING LEAD-FREE SOLDER PASTE.

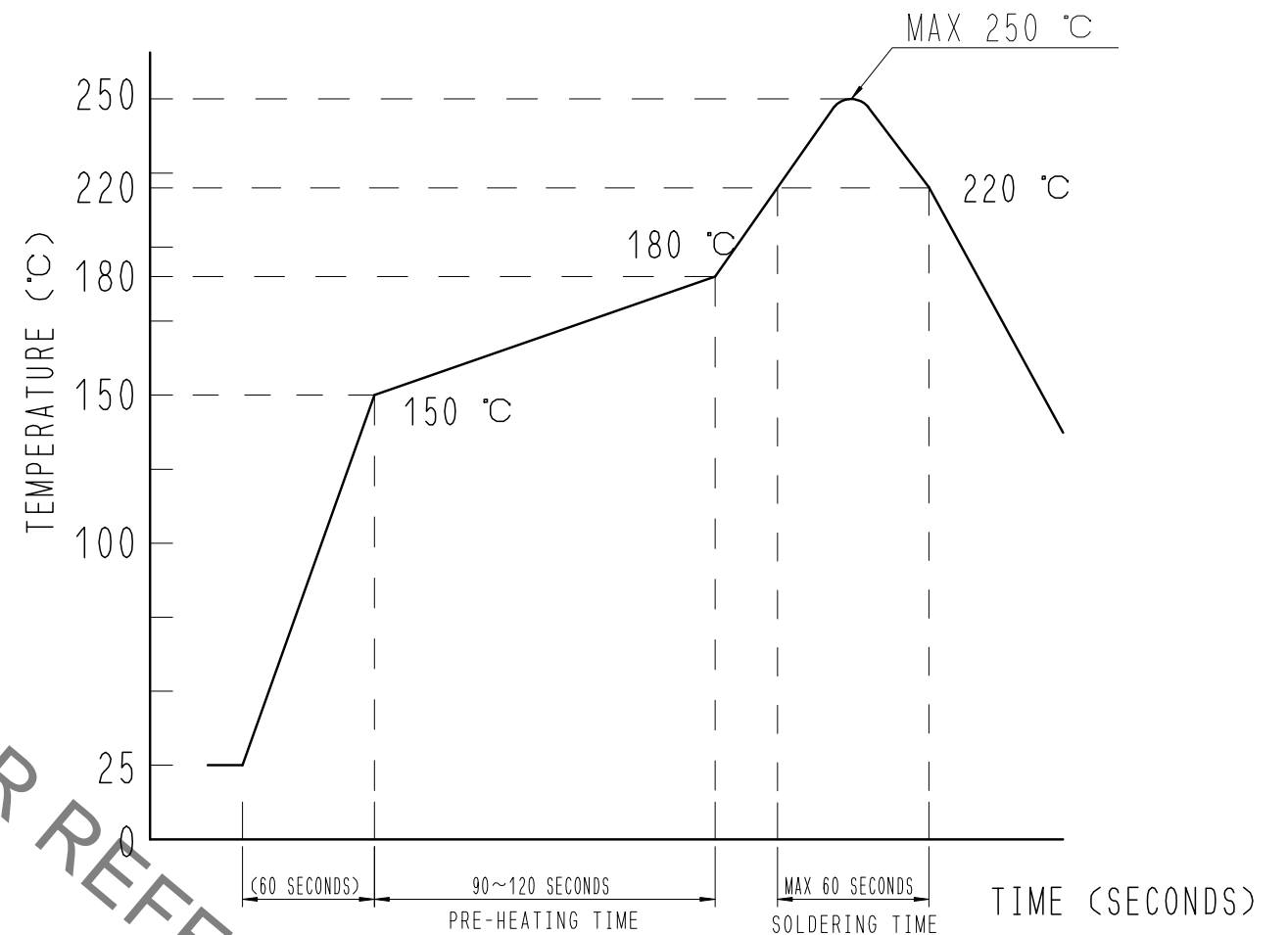

REFLOW METHOD: IR REFLOW
 NUMBER OF REFLOW CYCLES: 2 CYCLES MAX.
 1) REFLOW TIME
 DURATION ABOVE 220°C: 60 SEC MAX.
 (PEAK TEMPERATURE: 250°C MAX)
 2) PRE-HEAT TIME
 PRE-HEAT TEMPERATURE (MIN): 150°C
 PRE-HEAT TEMPERATURE (MAX): 180°C
 PRE-HEAT TIME: 90-120 SEC.

- 5 THIS TEMPERATURE PROFILE IS PER THE CONDITIONS SHOWN ABOVE. ADDITIONAL FACTORS, SUCH AS SOLDER PASTE TYPE, PCB SIZE AND OTHER MOUNTED COMPONENTS COULD AFFECT THE PROFILE, THEREFORE, A THOROUGH EVALUATION OF MOUNTING CONDITION IS REQUIRED PRIOR TO PRODUCTION. TEMPERATURE IS MEASURED AT CONTACT LEAD.
- 6 PLEASE CONTACT US IN CASE YOU WILL MAKE DIFFERENT SETTINGS FROM OUR RECOMMENDATION.

	DRAWING NO.	EDC3-*****	PART NO.	BM23FR0.6-**-DS-0.35V(51)
	SCALE	10:1	CODE NO	CL 66**-*****-***
UNITS	mm	HRS HIROSE KOREA CO., LTD.		2/3

Jan. 1.2022 Copyright 2022 HIROSE ELECTRIC CO., LTD. All Rights Reserved.
In case of consideration for using Automotive equipment / device which demand high reliability, kindly contact our sales window correspondents.

EMBOSED CARRIER TAPE PACKAGING (5:1)

L-L (5:1)

△ STYLE AND DIMENTION OF REEL (FREE)

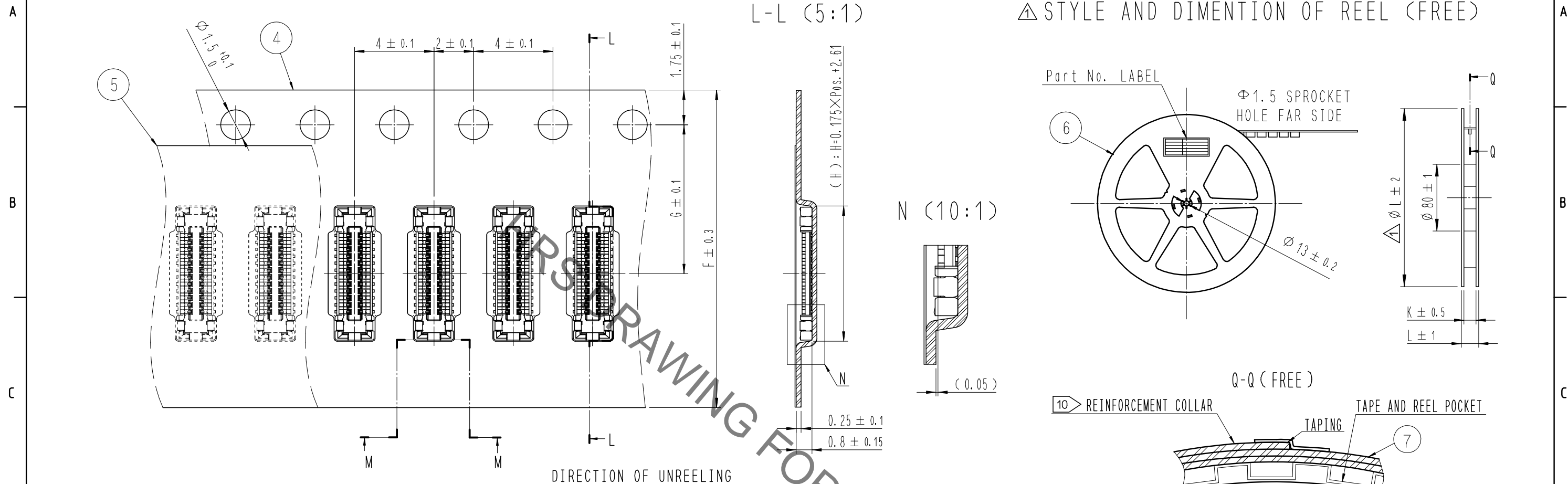

M-M (5:1)

N (10:1)

Q-Q (FREE)

△ POS.	F	G	H	J	K	L
6	12	5.5	3.66	13.5	17.5	330
8	12	5.5	4.01	13.5	17.5	330
10	16	7.5	4.36	17.5	21.5	380
12	16	7.5	4.71	17.5	21.5	330
16	16	7.5	5.41	17.5	21.5	330
20	16	7.5	6.11	17.5	21.5	380
24	16	7.5	6.81	17.5	21.5	380
△ 30	24	11.5	7.86	25.5	29.5	330
34	24	11.5	8.56	25.5	29.5	380
40	24	11.5	9.61	25.5	29.5	330
50	24	11.5	11.36	25.5	29.5	330

DETAIL OF PART No. LABEL

SUPPLIER	
QUANTITY	
PART NO.	
CODE NO.	
DATE OF MANUFACTURED	
生産月日	年 月 日
図番	** ** *
品名	BM23FR0.6-**DS-0.35V(51)
納入数量	10,000個
納入者	HIROSE KOREA

9 TAPING(FREE)

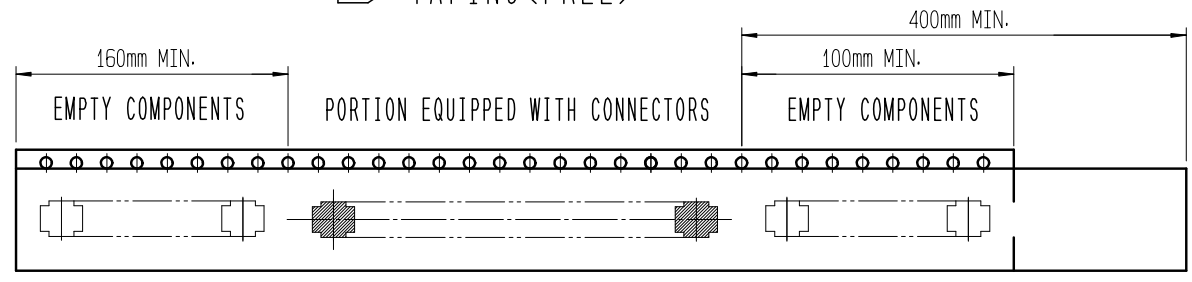

- 7 . PER REEL 10,000 CONNECTORS.
- 8 . THE DIMENSIONS IN PARENTHESES ARE FOR REFERENCE.
- 9 REFER TO JIS C 0806, IEC-60286-3 (PACKAGING OF COMPONENTS FOR AUTOMATIC HANDLING)
- 10 AFTER PACKAGING, ROLL 2 METERS OF THE REINFORCEMENT COLLAR TO OUTER CIRCUMFERENCE OF TAPE AND REEL POCKET. AND TAPE DOWN AT THE END THE COLLAR.

DRAWING NO. EDC3-*****	PART NO. BM23FR0.6-**DS-0.35V(51)	CODE NO. CL 66**-*****-***	3/3

Mouser Electronics

Authorized Distributor

Click to View Pricing, Inventory, Delivery & Lifecycle Information:

[Hirose Electric:](#)

[BM23FR0.6-20DS-0.35V\(51\)](#)