

## 2 General Description

The MLX91206 is a monolithic sensor IC featuring the Triaxis<sup>®</sup> Hall technology. Conventional planar Hall technology is only sensitive to the flux density applied orthogonally to the IC surface. The IMC-Hall<sup>®</sup> current sensor is sensitive to the flux density applied parallel to the IC surface. This is obtained through an Integrated Magneto-Concentrator (IMC-Hall<sup>®</sup>) which is deposited on the CMOS die (as an additional back-end step). The IMC-Hall<sup>®</sup> current sensor is automotive qualified.

The product is a single chip Hall sensor which provides an output signal which is proportional to the flux density applied horizontally and is therefore suitable for current measurement. It is ideally used as an open loop current sensor for PCB mounting. (see figure 2). It features small size application design and a simple construction for various current ranges.

The transfer characteristic of the MLX91206 is programmable (offset, gain, clamping levels, diagnostic functions...). The output is selectable between analog and PWM. The linear analog output is used for application where a very fast response ( $<10 \mu\text{sec}$ ) is required, whereas the PWM output is used for application where low speed but high output signal robustness is required.

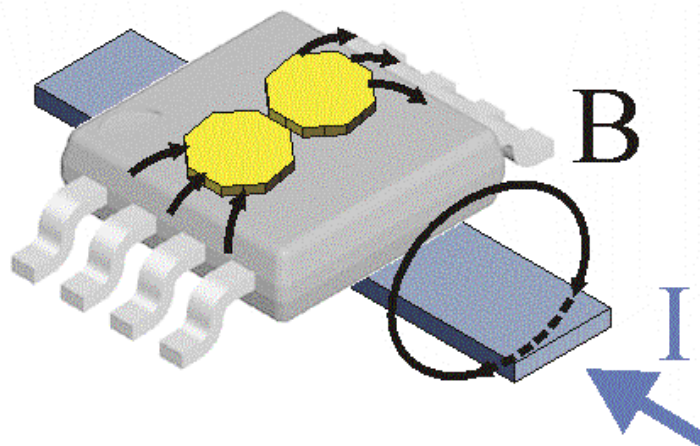

Figure 2: Typical application of MLX91206

### Table of Contents

|   |    |
|---|----|
| 1 Functional Diagram.....   | 1  |
| 2 General Description.....  | 2  |
| 3 Glossary of Terms.....  | 4  |
| 4 Absolute Maximum Ratings.....   | 4  |
| 5 Pin Definitions and Descriptions.....   | 4  |
| 6 General Electrical Specifications.....  | 5  |
| 7 Magnetic specification.....   | 6  |
| 7.1 25 mT version (marking xxH).....  | 6  |
| 7.2 10 mT version (marking xxL).....  | 6  |
| 8 Analog output specification.....  | 7  |
| 8.1 Timing specification.....   | 7  |
| 8.2 Accuracy specification.....   | 7  |
| 8.3 Remarks to the achievable accuracy.....   | 7  |
| 9 PWM output specification.....   | 8  |
| 9.1 Timing specification for the PWM output.....  | 8  |
| 9.2 Magnetic specification for the PWM output.....  | 9  |
| 9.3 Accuracy specification transfer characteristic PWM.....   | 9  |
| 10 Thermometer output specification.....  | 9  |
| 11 Programmable items.....  | 10 |
| 11.1 Parameter table.....   | 10 |
| 11.2 Output mode configuration (DSPMODE, OUTMODE).....  | 11 |
| 11.3 Output impedance mode (DIAGINFALT).....  | 11 |
| 11.4 Reference edge (REFEDGE) – only in PWM mode.....   | 11 |
| 11.5 PWM/switch mode (SWITCH).....  | 11 |
| 11.6 Platepol (PLATEPOL).....   | 12 |
| 11.7 Sensitivity programming (ROUGHGAIN, FINEGAIN).....   | 12 |
| 11.8 Offset / output quiescent voltage programming (XA, YA).....  | 13 |
| 11.9 Clamping level programming (CLAMPLOW, CLAMPHIGH).....  | 13 |
| 11.10 Bandwidth and filter programming (FILTCODE).....  | 14 |
| 11.11 Power limitation / PWM rise and fall time (OUTSLOPE).....   | 15 |
| 11.12 PWM Mode duty cycle definition (DCDEF).....   | 16 |
| 11.13 Output ratiometry (RATIODIS).....   | 16 |
| 11.14 Sensitivity and temperature drift programming (TC1ST, TC2ND_COLD, TC2ND_HOT).....                         | 16 |
| 11.15 Offset temperature drift programming (OFFDRIFT_COLD, OFFDRIFT_HOT).....                                   | 16 |
| 11.16 Product Identification (MLXID, CSTID).....  | 17 |
| 12 Application information.....   | 18 |
| 12.1 Low current measurement up to ±2 A.....  | 18 |
| 12.2 Medium current up to ±30 A.....  | 18 |
| 12.3 High current measurement up to ±600 A.....   | 18 |
| 13 Recommended Application Diagrams.....  | 19 |
| 13.1 Resistor and capacitor values.....   | 19 |
| 13.2 Fast analog application, pull-down resistor for diagnostic low.....  | 19 |
| 13.3 Fast analog application, pull-up resistor for diagnostic high.....   | 20 |
| 13.4 Robust PWM application, (pull-up load only).....   | 20 |
| 14 Standard information regarding manufacturability of Melexis products with different soldering processes..... | 21 |
| 15 ESD Precautions.....   | 21 |
| 16 Package Information.....   | 22 |
| 16.1 SOIC8 Package dimensions.....  | 22 |
| 16.2 SOIC8 Pinout and Marking.....  | 22 |
| 16.3 SOIC8 Hall plate position.....   | 23 |
| 16.4 IMC Position and sensors active measurement direction.....   | 23 |
| 17 Related documents and tools.....   | 24 |
| 17.1 Related documents.....   | 24 |
| 17.2 Related software.....  | 24 |
| 17.3 Related hardware.....  | 24 |
| 18 Disclaimer.....  | 25 |

### 3 Glossary of Terms

|       |  |
|-------|--|
| Tesla | Units for the magnetic flux density, 1 mT = 10 Gauss               |
| TC    | Temperature Coefficient in ppm/deg C                               |
| NC    | Not Connected  |
| PWM   | Pulse Width Modulation   |
| %DC   | Duty Cycle of the output signal i.e. $T_{ON} / (T_{ON} + T_{OFF})$ |
| ADC   | Analog to Digital Converter  |
| DAC   | Digital to Analog Converter  |
| LSB   | Least Significant Bit  |
| MSB   | Most Significant Bit   |
| DNL   | Differential Non Linearity   |
| INL   | Integral Non Linearity   |
| IMC   | Integrated Magneto Concentrator (IMC <sup>®</sup> )                |
| PTC   | Programming Through Connector                                      |

### 4 Absolute Maximum Ratings

| Parameter                             | Symbol           | Value  | Units |
|---------------------------------------|------------------|--|-------|
| Positive Supply Voltage (overvoltage) | Vdd              | +20  | V     |
| Reverse Supply Voltage Protection     |                  | -10  | V     |
| Positive Output Voltage               |                  | +10<br>+14 (200 s max, T <sub>A</sub> = +25°C) | V     |
| Output Current                        | I <sub>out</sub> | ±300   | mA    |
| Reverse Output Voltage                |                  | -0.3   | V     |
| Reverse Output Current                |                  | -50  | mA    |
| Operating Ambient Temperature Range   | T <sub>A</sub>   | -40 to +150                                    | °C    |
| Storage Temperature Range             | T <sub>S</sub>   | -55 to +165                                    | °C    |
| Magnetic Flux Density                 |                  | ±0.2   | T     |

Table 1: Absolute maximum ratings

Exceeding the absolute maximum ratings may cause permanent damage. Exposure to absolute maximum rated conditions for extended periods may affect device reliability.

### 5 Pin Definitions and Descriptions

| Pin № | Name      | Type           | Function  |
|-------|-----------|----------------|---|
| 1     | VDD       | Supply         | Supply Voltage                                    |
| 2     | VSS       | Ground         | Supply Voltage                                    |
| 3     | VDIG      | Supply         | Digital supply voltage, 3.3 V, internal regulated |
| 4     | MUST1     | Digital        | Test and Factory calibration                      |
| 5     | OUT / PWM | Analog/Digital | Current sensor output                             |
| 6     | TESTOUT   | Digital        | Test and Factory calibration                      |
| 7     | MUST0     | Digital        | Test and Factory calibration                      |
| 8     | TEMPOUT   | Analog         | Temperature Sensor Output                         |

Table 2: Pin definition and description

It is recommended to connect the unused pins to the Ground (see section 16) for optimal EMC results.

### 6 General Electrical Specifications

Operating Parameters :  $T_A = -40$  to  $125\text{degC}$ ,  $V_{dd} = 4.5\text{ V}$  to  $5.5\text{ V}$ ,  $I_{out} = -2\text{ mA}$  to  $+2\text{ mA}$ , recommended application diagram in section 16, unless otherwise specified. All mentioned component values can have a  $\pm 20\%$  tolerance

| Parameter  | Symbol   | Test Conditions                                      | Min              | Typ | Max               | Units         |
|--|--|--|------------------|-----|-------------------|---------------|
| Nominal Supply Voltage                           | Vdd  |  | 4.5              | 5   | 5.5               | V             |
| Supply Current                                   | Idd  | W/o output load & $T_A = -40$ to $150^\circ\text{C}$ |                  | 7   | 10                | mA            |
|  |  | - ROUGHGAIN $\leq 3$<br>- ROUGHGAIN $> 3$            |                  | 9   | 12                | mA            |
| Output Current                                   | Iout   |  | -2               |     | 2                 | mA            |
| Output Resistance                                |  | $V_{out} = 50\% V_{dd}$ , $R_L = 5\text{k}\Omega$    |                  | 1   | 5                 | $\Omega$      |
| Output Capacitive Load                           | Cload  | Analog Mode  | 5                | 10  | 50                | nF            |
|  |  | PWM Mode   | 0                | 10  | 50                | nF            |
| Output Short Circuit Current                     | Ishort   | Output shorted to Vdd - Permanent                    | Not Destroyed    |     |                   |               |
|  |  | Output shorted to Vss - Permanent                    | Not Destroyed    |     |                   |               |
| Leakage current                                  | Ileak  | High impedance mode <sup>(2)</sup>                   |                  |     | 5                 | $\mu\text{A}$ |
| Output Voltage Swing (Linear Range)              | Vout_pd  | pull down $\geq 10\text{ k}\Omega$                   | 5                |     | 95                | %Vdd          |
|  | Vout_pu  | pull up $\geq 10\text{ k}\Omega$                     | 5                |     | 95                | %Vdd          |
| High-impedance mode levels <sup>(2)</sup>        | Vout_HIz_pu  | pull-up $R_L \leq 30\text{ k}\Omega$                 | 97               |     |                   | %Vdd          |
|  | Vout_HIz_pd  | pull-down $R_L \leq 30\text{ k}\Omega$               |                  |     | 3                 | %Vdd          |
| BrokenVss Output Levels <sup>(2)</sup>           | OUT with pull-down $R_L \leq 10\text{ k}\Omega$ <sup>(3)</sup> |  |                  |     | 3                 | %Vdd          |
|  | OUT with pull-up $R_L \leq 30\text{ k}\Omega$ <sup>(3)</sup>   |  | 97               |     |                   | %Vdd          |
| BrokenVdd Output Levels <sup>(2)</sup>           | OUT with pull-down $R_L \leq 30\text{ k}\Omega$ <sup>(3)</sup> |  |                  |     | 3                 | %Vdd          |
|  | OUT with pull-up $R_L \leq 30\text{ k}\Omega$ <sup>(3)</sup>   |  | 97               |     |                   | %Vdd          |
| Under-voltage detection <sup>(2) (4)</sup>       | Vdd_uvd  | Detected Voltage (Low to High)                       | 3.15             | 3.3 | 3.45              | V             |
|  | Vdd_uvh  | Hysteresis   | 0.25             | 0.3 | 0.4               | V             |
| Over-voltage detection mode 1 <sup>(2) (4)</sup> | Vdd_ovd1   | Detected Voltage (Low to High)                       | 7.8              |     | 9.5               | V             |
|  | Vdd_ovh1   | Hysteresis   | 0.8              |     | 1.6               | V             |
| Over-voltage detection mode 2 <sup>(2) (4)</sup> | Vdd_ovd2   | Detected Voltage (Low to High)                       | 6.7              |     | 7.6               | V             |
|  | Vdd_ovh2   | Hysteresis   | 0.05             |     | 0.5               | V             |
| Clamped Output Level                             | Clamp_lo   | Trimming Range                                       | 5 <sup>(1)</sup> |     | 10                | %Vdd          |
|  | Clamp_hi   | Trimming Range                                       | 90               |     | 95 <sup>(1)</sup> | %Vdd          |

Table 3: General electrical parameter

- (1) Factory programmed clamping level
- (2) Refer to chapter **Self-diagnostic, table 21**.
- (3) Valid for TEMPOUT with pull-up (min. 30k $\Omega$ ), pull-down (min. 30k $\Omega$ ) or not connected
- (4) According to the figure below

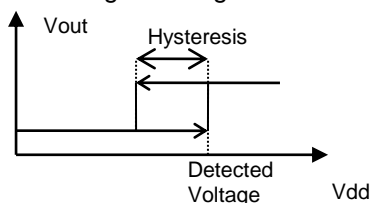

Figure "Detected voltage and hysteresis definitions"

## 7 Magnetic specification

### 7.1 25 mT version (marking xxH)

Operating Parameters  $T_A = -40$  to  $125\text{degC}$ ,  $V_{dd} = 4.5$  V to  $5.5$  V, unless otherwise specified.

| Parameter                               | Symbol | Test Conditions                | Min   | Typ | Max   | Units |
|---|--------|--------------------------------|-------|-----|-------|-------|
| Nominal Field Range                     | Bnom   |                                | -20   |     | +20   | mT    |
| Operational Field Range <sup>(1)</sup>  | Bop    |                                | -25   |     | +25   | mT    |
| Linearity Error                         | NL     | Nominal Field Range (25°C)     | -0.5  |     | +0.5  | %FS   |
|   |        | Operational Field Range (25°C) | -0.75 |     | +0.75 | %FS   |
| Hysteresis, remanent Field              | Br     | B = Bop                        | -25   |     | +25   | uT    |
| Programmable Sensitivity <sup>(2)</sup> | S      | B = Bop , Analog Mode          | 80    |     | 330   | mV/mT |
| Sensitivity programming Resolution      | Sres   | B = Bop                        |       | 0.1 |       | %     |

Table 4: Magnetic specification 25mT version (high-field version)

- (1) Above 25 mT, the IMC starts saturating yielding to an increase of the linearity error.  
(2) The specified programmable sensitivity range is covered by 5 different versions (option codes)

| Option code (25mT) | Programmed Sensitivity | Sensitivity Range |
|--------------------|------------------------|-------------------|
| CAH-001            | 270mV/mT               | 210 - 330mV/mT    |
| CAH-002            | 170mV/mT               | 130 - 220mV/mT    |
| CAH-003            | 110mV/mT               | 80 - 140mV/mT     |
| CAH-004            | 77.5mV/mT              | 60 - 110mV/mT     |
| CAH-021            | 270mV/mT               | 210 - 330mV/mT    |

### 7.2 10 mT version (marking xxL)

Operating Parameters  $T_A = -40$  to  $125\text{degC}$ ,  $V_{dd} = 4.5$  V to  $5.5$  V (unless otherwise specified)

| Parameter                               | Symbol | Test Conditions                | Min   | Typ | Max   | Units             |
|---|--------|--------------------------------|-------|-----|-------|-------------------|
| Nominal Field Range                     | Bnom   |                                | -7.5  |     | +7.5  | mT                |
| Operational Field Range <sup>(3)</sup>  | Bop    |                                | -10   |     | +10   | mT <sup>(2)</sup> |
| Linearity Error                         | NL     | Nominal Field Range (25°C)     | -0.5  |     | +0.5  | %FS               |
|   |        | Operational Field Range (25°C) | -0.75 |     | +0.75 | %FS               |
| Hysteresis, remanent Field              | Br     | B = Bop                        | -10   |     | +10   | uT                |
| Programmable Sensitivity <sup>(4)</sup> | S      | B = Bop , Analog Mode          | 200   |     | 700   | mV/mT             |
| Sensitivity programming Resolution      | Sres   | B = Bop                        |       | 0.1 |       | %                 |

Table 5: Magnetic specification 10mT version (low-field version)

- (3) Above 10 mT, the IMC starts saturating yielding to an increase of the linearity error.  
(4) The specified programmable sensitivity range is covered by 3 different versions (option codes)

| Option code (10mT) | Programmed Sensitivity | Sensitivity Range |
|--------------------|------------------------|-------------------|
| CAL-001            | 580mV/mT               | 460-700mV/mT      |
| CAL-002            | 380mV/mT               | 300-470mV/mT      |
| CAL-003            | 250mV/mT               | 200-310mV/mT      |

## 8 Analog output specification

### 8.1 Timing specification

Operating Parameters  $T_A = -40$  to  $125\text{degC}$ ,  $V_{dd} = 4.5$  V to  $5.5$  V (unless otherwise specified)

| Parameter                    | Symbol             | Test Conditions   | Min | Typ | Max                 | Units                |
|------------------------------|--------------------|---|-----|-----|---------------------|----------------------|
| Step Response Time           | T <sub>resp</sub>  | Voq $\pm$ 2 V   |     | 8   | 10                  | $\mu$ s              |
| Bandwidth                    | BW                 | Full Range  | 50  | 70  | 90                  | kHz                  |
| Power on Delay               | T <sub>POD</sub>   | V <sub>out</sub> = 100% of FS<br>(BW = 100 Hz)<br>(BW = 1000 Hz)<br>(BW = 10 kHz)<br>(BW = 100 kHz – No filter) |     |     | 100<br>10<br>5<br>5 | ms<br>ms<br>ms<br>ms |
| Ratiometry Cut-off Frequency | F <sub>ratio</sub> |   |     | 250 |                     | Hz                   |

Table 6: Timing specification high speed analog output

### 8.2 Accuracy specification

Operating Parameters  $T_A = -40$  to  $125\text{degC}$ ,  $V_{dd} = 4.5$  V to  $5.5$  V (unless otherwise specified)

| Parameter                                 | Symbol               | Test Conditions   | Min  | Typ | Max  | Units            |
|---|----------------------|---|------|-----|------|------------------|
| Thermal Offset Drift                      | $\Delta^T\text{Voq}$ |   | -0.4 |     | +0.4 | %V <sub>dd</sub> |
| Thermal Offset Drift <sup>(1)</sup>       | $\Delta^T\text{Voq}$ |   | -20  |     | 20   | mV               |
| Thermal Sensitivity Drift                 | TC                   |   | -1.5 |     | +1.5 | %S               |
| RMS Output noise                          | N <sub>rms</sub>     | S = 6 %V <sub>dd</sub> /mT (= 300 mV/mT @ V <sub>dd</sub> =5V)                                |      |     | 0.1  | %V <sub>dd</sub> |
| Voq Ratiometry                            | $\Delta\text{Voq}$   | Voq = 50%V <sub>dd</sub><br>$\Delta\text{V}_{dd} = 10\%V_{dd}$                                | 9.8  |     | 10.2 | %                |
| Voq Drift – Supply Related <sup>(1)</sup> | $\Delta\text{Voq}$   | Voq = 50%V <sub>dd</sub> (V <sub>dd</sub> Nominal = 5V)<br>$\Delta\text{V}_{dd} = 10\%V_{dd}$ | -5   |     | 5    | mV               |
| Sensitivity Ratiometry                    | $\Delta\text{S}$     | $\Delta\text{V}_{dd} = 10\%V_{dd}$<br>B = Bop   | 9.8  |     | 10.2 | %                |
| Clamped output accuracy                   | Clamp_lo<br>Clamp_hi | Trimming range: 5-10%V <sub>dd</sub><br>Trimming range: 90-95%V <sub>dd</sub>                 | -1   |     | 1    | %V <sub>dd</sub> |

Table 7: Accuracy specific parameter analog output

(1) Applies to CAH-021 version

### 8.3 Remarks to the achievable accuracy

The achievable target accuracy is dependent on user's end-of-line calibration. The resolution for the offset and offset drift calibration is better than 0.1%V<sub>dd</sub>. Trimming capability is higher than the measurement accuracy. End-user calibration can increase the accuracy of the system.

## 9 PWM output specification

### 9.1 Timing specification for the PWM output

Operating Parameters  $T_A = -40$  to  $125\text{degC}$ ,  $V_{DD} = 4.5$  V to  $5.5$  V (unless otherwise specified)

| Parameter                             | Symbol       | Test Conditions   | Min | Typ   | Max  | Units            |
|---------------------------------------|--------------|---|-----|-------|------|------------------|
| Main Oscillator Frequency             | $F_{OSC}$    | Tolerance $\pm 10\%$  | 900 | 1024  | 1100 | kHz              |
| PWM Output Frequency                  | $F_{PWM}$    |   | 110 | 125   | 140  | Hz               |
| Tick Time (resolution in time domain) | $t_{TICK}$   |   |     | 1     |      | $\mu\text{s}$    |
| PWM Output Resolution                 | R(PWM)       | 12 Bit, Theoretical Jitter free   |     | 0.025 |      | %DC              |
| PWM Jitter (1 Sigma)                  | J (PWM)      | FILTCODE = 5<br>(70 Hz Digital LowPass Filter)  |     | 0.01  |      | %DC<br>(1 Sigma) |
| Output Rise Time<br>(10%-90%)         | $t_{RISEOD}$ | Push-pull mode<br>$R_L = 4.7\text{ k}\Omega$ to $5\text{ V}$ , $C_L = 10\text{ nF}$<br>OUTSLOPE = 0               |     | 11    |      | $\mu\text{s}$    |
|                                       |              | OUTSLOPE = 1  |     | 7     |      | $\mu\text{s}$    |
|                                       |              | OUTSLOPE = 2  |     | 4     |      | $\mu\text{s}$    |
|                                       |              | OUTSLOPE = 3  |     | 2.5   |      | $\mu\text{s}$    |
| Output Fall Time<br>(90%-10%)         | $T_{FALLOD}$ | Push-pull or open-drain mode<br>$R_L = 4.7\text{ k}\Omega$ to $5\text{ V}$ , $C_L = 10\text{ nF}$<br>OUTSLOPE = 0 |     | 14    |      | $\mu\text{s}$    |
|                                       |              | OUTSLOPE = 1  |     | 8     |      | $\mu\text{s}$    |
|                                       |              | OUTSLOPE = 2  |     | 4.5   |      | $\mu\text{s}$    |
|                                       |              | OUTSLOPE = 3  |     | 2.5   |      | $\mu\text{s}$    |
| Clamped Output Level                  | Clamp_lo     | Programmable  | 1   |       | 10   | %DC              |
|                                       | Clamp_hi     | Programmable  | 90  |       | 99   | %DC              |
| Power-on delay                        | $T_{POD}$    |   |     |       | 11   | ms               |

Table 8: Timing specification for the PWM output

## 9.2 Magnetic specification for the PWM output

Operating Parameters  $T_A = -40$  to  $125\text{degC}$ ,  $V_{dd} = 4.5$  V to  $5.5$  V, unless otherwise specified.

| Parameter                              | Symbol | Test Conditions                | Min   | Typ | Max   | Units  |
|--|--------|--------------------------------|-------|-----|-------|--------|
| Nominal Field Range                    | Bnom   |                                | -20   |     | +20   | mT     |
| Operational Field Range <sup>(1)</sup> | Bop    |                                | -25   |     | +25   | mT     |
| Linearity Error                        | NL     | Nominal Field Range (25°C)     | -0.5  |     | +0.5  | %FS    |
|  |        | Operational Field Range (25°C) | -0.75 |     | +0.75 | %FS    |
| Hysteresis, remanent Field             | Br     | B = Bop                        | -25   |     | +25   | uT     |
| Programmable Sensitivity               | S      | B = Bop                        | 0.5   |     | 5     | %DC/mT |
| Sensitivity programming Resolution     | Sres   | B = Bop                        |       | 0.1 |       | %      |

Table 9: Magnetic specification 25mT version (high-field version)

(1) Above 25 mT, the IMC starts saturating yielding to an increase of the linearity error.

## 9.3 Accuracy specification transfer characteristic PWM

Operating Parameters  $T_A = -40$  to  $125\text{degC}$ ,  $V_{dd} = 5.0$  V (unless otherwise specified),  $S = 4\%$ DC/mT

| Parameter                 | Symbol            | Test Conditions | Min  | Typ | Max  | Units  |
|---------------------------|-------------------|-----------------|------|-----|------|--------|
| Thermal Offset Drift      | $\Delta^T V_{oq}$ |                 | -0.4 |     | +0.4 | %DC    |
| Thermal Sensitivity Drift | TC                |                 | -150 |     | +150 | ppm/°C |

Table 10: Accuracy specific parameter PWM output

## 10 Thermometer output specification

The thermometer output voltage is in the range from 367mV to 2930mV for temperatures ranging from -40 to 150degC. The accuracy is better than 5degC. The pin shall be able to sustain a low impedance connection to maximum 14V. This output is not ratiometric.

| Parameter      | Symbol                 | Test Conditions                         | Min  | Typ  | Max  | Units   |
|----------------|------------------------|---|------|------|------|---------|
| Offset         | $T_{35}$               | Output voltage with $T = 35\text{degC}$ |      | 1.38 |      | V       |
| Slope          | $T_{\text{slope}}$     |   |      | 13.5 |      | mV/degC |
| Accuracy       | $T_{\text{acc}}$       |   | -5   |      | 5    | degC    |
| Load capacitor | $C_{\text{loadTherm}}$ | External through bonding wire           |      | 1    | 50   | nF      |
| Output current | $I_{\text{outtherm}}$  |   | -0.1 |      | +0.1 | mA      |

Table 11: Thermometer output specification



## 11 Programmable items

### 11.1 Parameter table

Customers can re-program the parameters described in the table below by using the Melexis PTC-04 hardware and the Product Specific Functions (PSF) libraries provided by Melexis. We recommend using the latest version of the PSF and the latest version of the firmware with a communication speed of 10kbps (limited by a maximum output capacitor of 50nF). Software and firmware are available on the softdist platform (see contact details on page 25 to request an account).

| Parameter               | Bits | Factory Setting    | Comment   |
|-------------------------|------|--------------------|---|
| DSPMODE                 | 1    | 0                  | Selection analog or PWM output                                      |
| OUTMODE                 | 1    | 1                  | Capacitive load selection in analog mode                            |
|                         |      | N/A                | Push pull or open drain output drive in PWM mode                    |
| DIAGINFALT              | 1    | 0                  | Output impedance setting  |
| REFEDGE                 | 1    | 0                  | Not used in analog mode   |
|                         |      |                    | Diagnostic level & reference edge                                   |
| SWITCH                  | 1    | N/A                | Not used in analog mode   |
|                         |      | 0                  | PWM or SWITCH output selection                                      |
| PLATEPOL <sup>(1)</sup> | 1    | 0                  | Change of sensitivity sign  |
| ROUGHGAIN               | 3    | Trimmed            | Rough gain preamplifier   |
| FINEGAIN                | 10   | Trimmed            | Fine gain from 0.4 to 1.0 in analog mode                            |
|                         | 13   | Trimmed            | Fine gain from -3.999 to +3.999 in PWM mode                         |
| XA                      | 12   | Trimmed            | Offset compensation VOQ in analog mode                              |
|                         | 14   | Trimmed            | Digital offset in PWM mode  |
| YA                      | 9    | N/A                | Not used in analog mode   |
|                         |      | 32                 | Rough offset compensation in PWM mode                               |
| CLAMPLOW                | 3    | Trimmed            | Clamping low level in analog mode                                   |
|                         |      | N/A                | Not used in PWM mode  |
| CLAMPHIGH               | 3    | Trimmed            | Clamping high level in analog mode                                  |
|                         |      | 2                  | Clamping high and low level for PWM output                          |
| FILTCODE                | 3    | 0                  | Analog filter in analog mode  |
|                         | 4    | 2                  | Digital filter in PWM mode  |
| OUTSLOPE                | 2    | 3                  | Power limitation of the output driver on high frequencies in analog |
|                         |      |                    | Output slope control for PWM mode                                   |
| DCDEF                   | 1    | 0                  | Not used in analog mode   |
|                         |      | 1                  | PWM duty cycle definition   |
| RATIODIS <sup>(1)</sup> | 1    | 0/1 <sup>(2)</sup> | Enable/Disable ratiometry between output signal and supply          |
|                         |      | N/A                | Not used in PWM mode  |
| TC1ST                   | 7    | Trimmed            | Sensitivity temperature drift correction first order                |
| TC2ND_COLD              | 5    | Trimmed            | Sensitivity temperature drift correction second order for cold      |
| TC2ND_HOT               | 5    | Trimmed            | Sensitivity temperature drift correction second order for hot       |
| OFFDRIFT_COLD           | 6    | Trimmed            | Offset temperature drift correction for cold temperatures           |
| OFFDRIFT_HOT            | 6    | Trimmed            | Offset temperature drift correction for hot temperatures            |
| MLXID                   | 48   | Programmed         | MLX ID  |
| CSTID                   | 17   | N/A                | Customer ID   |

Table 92: Customer programmable items

(1): Changing these parameters has an impact on temperature calibration. (2): Default value is 1 only for CAH-021 version.

### 11.2 Output mode configuration (DSPMODE, OUTMODE)

DSPMODE activates the PWM or the analog mode for the output signal. OUTMODE configures the output driver.

| DSPMODE | OUTMODE | Output Driver   |
|---------|---------|---|
| 0       | 0       | Fast analog mode, $C_L = 1\text{nF}..10\text{nF}^{(1)(2)(3)}$   |
| 0       | 1       | Normal analog mode, $C_L = 5\text{nF}..50\text{nF}^{(1)(2)(4)}$ |
| 1       | 0       | PWM mode – Open drain   |
| 1       | 1       | PWM mode – Push pull  |

Table 13: Output configuration

- (1) See section 16,  $C_L = C_4$ .
- (2) Factory setting: DSPMODE = 0, OUTMODE = 1.
- (3) For applications directly integrated on a PCB, smaller capacitors are allowed at the output pins.
- (4) For a standalone application where a cable is connected at the output of the sensor.

### 11.3 Output impedance mode (DIAGINFAULT)

DIAGINFAULT sets the output impedance mode.

| DIAGINFAULT | Output impedance                       |
|-------------|--|
| 0           | Low impedance mode (normal mode)       |
| 1           | High impedance mode (diagnostic level) |

### 11.4 Reference edge (REFEDGE) – only in PWM mode

REFEDGE defines the diagnostic level and sets the reference edge.

| REFEDGE | Reference edge (PWM) |
|---------|----------------------|
| 0       | Falling edge         |
| 1       | Rising edge          |

### 11.5 PWM/switch mode (SWITCH)

In PWM mode, the output can be configured to switch mode.

| SWITCH | Operating mode      |
|--------|---------------------|
| 0      | Disable switch mode |
| 1      | Enable switch mode  |

### 11.6 Platepol (PLATEPOL)

The polarity of the Hall plate versus the output signal is programmable by the PLATEPOL parameter.

| PLATEPOL | Polarity |
|----------|----------|
| 0        | Positive |
| 1        | Negative |

Please note that the factory calibration is done with PLATEPOL=0 . Melexis cannot guarantee the magnetic specifications if this parameter is changed during customer calibration.

### 11.7 Sensitivity programming (ROUGHGAIN, FINEGAIN)

The sensitivity is programmable with 3 bits for ROUGHGAIN and 10 bits for FINEGAIN in analog output application from 60 to 330 V/T (91206-High-Field version) and from 200 to 700 V/T (Low-Field version). The FINEGAIN resolution depends on the programmed ROUGHGAIN setting. It typically ranges from 0.25V/T (ROUGHGAIN=7) up to 0.01V/T (ROUGHGAIN=0).

Different option codes correspond to different sensitivity ranges:

| Ordering Option Code | IMC Version | Typical Sensitivity | Minimum Sensitivity | Maximum Sensitivity |
|----------------------|-------------|---------------------|---------------------|---------------------|
| CAL-001              | Low field   | 580 mV/mT           | 460 mV/mT           | 700 mV/mT           |
| CAL-002              |             | 380 mV/mT           | 300 mV/mT           | 470 mV/mT           |
| CAL-003              |             | 250 mV/mT           | 200 mV/mT           | 310 mV/mT           |
| CAH-001              | High field  | 270 mV/mT           | 210 mV/mT           | 330 mV/mT           |
| CAH-002              |             | 170 mV/mT           | 130 mV/mT           | 220 mV/mT           |
| CAH-003              |             | 110 mV/mT           | 80 mV/mT            | 140 mV/mT           |
| CAH-004              |             | 77.5 mV/mT          | 60 mV/mT            | 110 mV/mT           |
| CAH-021              |             | 270mV/mT            | 210 mV/mT           | 330mV/mT            |
| CAH-104              |             | 3 %DC/mT            | 0.5 %DC/mT          | 5 %DC/mT            |

In order to have a safety margin regarding mechanical tolerances Melexis recommends designing the application in such a way that the typical sensitivity can be used with. If the target sensitivity of the module is out of the defined range (see table above), the hardware and software tools provided by Melexis will not be able to properly calibrate the sensor.

Different option codes correspond to different electric gains:

| Ordering Option Code | IMC Version | Typical Rough Gain | Electrical Gain | Typical Voq drift [mV] | Typical Noise [mV RMS] |
|----------------------|-------------|--------------------|-----------------|------------------------|------------------------|
| CAL-001              | Low field   | 7                  | 240             | 18                     | 5                      |
| CAL-002              |             | 6                  | 155             | 14                     | 3.5                    |
| CAL-003              |             | 5                  | 100             | 9                      | 2.5                    |
| CAH-001              | High field  | 7                  | 240             | 18                     | 5                      |
| CAH-021              |             | 7                  | 240             | 18                     | 5                      |
| CAH-002              |             | 6                  | 155             | 14                     | 3.5                    |
| CAH-003              |             | 5                  | 100             | 9                      | 2.5                    |

Since noise and offset drift of the sensor are proportional to the electric gain of the sensor, Melexis recommends using the version with the smallest gain to optimize the performances.

Note: Power consumption is 2mA less if ROUGHGAIN ≤ 3

## 11.8 Offset / output quiescent voltage programming (XA, YA)

### XA

In analog mode

- 12-bit register
- Offset compensation before gain
- @ 0 Gauss w/o offset & @Vdd=5V →  $V_{out} = 6.25 * (VOQ \text{ Code}) / 4096$  (clipping can occur!)
- Programming resolution: 1.5mV per LSB over the full output range. This corresponds to a calibration resolution of 0.03%Vdd

In PWM mode

- 14-bit register – digital offset VOQ
- Offset compensation before gain

### YA

Not used in analog mode

In PWM mode

- 9-bit register
- Rough offset compensation (after gain)

## 11.9 Clamping level programming (CLAMPLOW, CLAMPHIGH)

The clamping levels limit the maximum output levels. CLAMPLOW is not used in PWM application. The clamping levels are ratiometric (if RATIODIS = 0)

| CLAMPLOW | Minimal output [%Vdd] |
|----------|-----------------------|
| 0        | 4.8                   |
| 1        | 5.7                   |
| 2        | 6.6                   |
| 3        | 7.5                   |
| 4        | 8.4                   |
| 5        | 9.3                   |
| 6        | 10.2                  |
| 7        | 11.2                  |

Table 14: Clamping low level table analog (typical values)

| CLAMPHIGH | Maximal output [%Vdd] |
|-----------|-----------------------|
| 0         | 90.6                  |
| 1         | 91.4                  |
| 2         | 92.4                  |
| 3         | 93.3                  |
| 4         | 94.3                  |
| 5         | 95.2                  |
| 6         | 96.1                  |
| 7         | 97                    |

Table 15: Clamping high level analog mode (typical values).

The clamping functionality can be disabled by programming CLAMPLOW=CLAMPHIGH=7

| CLAMPHIGH | Minimal output [%DC] | Maximal output [%DC] |
|-----------|----------------------|----------------------|
| 0         | 1                    | 99                   |
| 1         | 4                    | 96                   |
| 2         | 5                    | 95                   |
| 3         | 6                    | 94                   |
| 4         | 7                    | 93                   |
| 5         | 8                    | 92                   |
| 6         | 9                    | 91                   |
| 7         | 10                   | 90                   |

Table 16: Clamping low and high duty-cycle in PWM mode.

The clamping functionality can be disabled by programming CLAMPLOW=CLAMPHIGH=7.

The clamping levels calibrated during final test are:

- 6%Vdd (+/- 0.5%Vdd) for CLAMPING LOW
- 94%Vdd (+/- 0.5%Vdd) for CLAMPING HIGH

### 11.10 Bandwidth and filter programming (FILTCODE)

FILTCODE allows adjusting the internal bandwidth of the sensor in order to optimize for speed or resolution.

| FILTCODE | Typical Bandwidth [kHz] |
|----------|-------------------------|
| 0        | 90 <sup>(1)</sup>       |
| 1        | 9                       |
| 2        | 40                      |
| 3        | 2                       |
| 4        | 9                       |
| 5        | 0.9                     |
| 6        | 4                       |
| 7        | 0.2                     |

Table 17: FILTCODE settings analog mode

(1) Factory settings: FILTCODE = 0.

| FILTCODE | Cut-off frequency [Hz] | Attenuation [dB] | Tau [ms] |
|----------|------------------------|------------------|----------|
| 2        | 557                    | -8.0             | 0.29     |
| 3        | 279                    | -11.2            | 0.57     |
| 4        | 139                    | -14.4            | 1.14     |
| 5        | 70                     | -18.1            | 2.29     |
| 6        | 35                     | -22.4            | 4.57     |
| 7        | 17                     | -27.1            | 9.14     |
| 8        | 9                      | -32.3            | 18.29    |
| 9        | 4                      | -38.1            | 36.57    |

Table 18: FILTCODE settings PWM mode

**Note:**

- In analog mode values above 7 are not used
- In PWM mode values below 2 and above 9 are not used

### 11.11 Power limitation / PWM rise and fall time (OUTSLOPE)

OUTSLOPE, in the analog mode case, defines the power limit above which the output driver turns off to prevent damages to the IC.

The power dissipated in the IC output driver is measured by the IC itself. The power is obtained by multiplying continuously the voltage across the conducting MOS driver by the output current  $I_{out}$ . When the power reaches the power limit, the output driver is switched off and on such that, on average, the measured power is maintained equal to the power limit. The power limitation is disabled when OUTSLOPE=3.

| Value | Power limitation [mW]   |
|-------|-------------------------|
| 0     | 50                      |
| 1     | 100                     |
| 2     | 200                     |
| 3     | DISABLED <sup>(1)</sup> |

Table 19: Output power limitation in analog mode

(1) Factory settings: OUTSLOPE = 3.

OUTSLOPE, in the PWM mode case, defines the rise and fall times of the PWM transients.

| Value | Typical Rise Time | Typical Fall Time | Current Limitation [mA] |
|-------|-------------------|-------------------|-------------------------|
| 0     | 11                | 14                | 5                       |
| 1     | 7                 | 8.5               | 7                       |
| 2     | 4                 | 4.5               | 13                      |
| 3     | 2.5               | 2.5               | 22                      |

Table 20: PWM rise and fall time,  $C_{out} = 10nF$ ,  $R_{pullup} = 4.7k\Omega$

### 11.12 PWM Mode duty cycle definition (DCDEF)

The PWM duty cycle definition is as follows.

| DCDEF | PWM duty cycle definition |
|-------|---------------------------|
| 0     | tLow / (tLow + tHigh)     |
| 1     | tHigh / (tLow + tHigh)    |

Table 21: PWM duty cycle definition

### 11.13 Output ratiometry (RATIODIS)

In case of analog mode (DSPMODE=0) RATIODIS allows enabling and disabling the ratiometry of the output in reference to the supply voltage by setting respectively 0 and 1 in the EEPROM.

| RATIODIS | Ratiometry |
|----------|------------|
| 0        | Enabled    |
| 1        | Disabled   |

Please note that the factory calibration is done with RATIODIS=0 excepted for the CAH-021 version where RATIODIS=1. Melexis cannot guarantee the magnetic specifications if this parameter is changed during customer calibration.

### 11.14 Sensitivity and temperature drift programming (TC1ST, TC2ND\_COLD, TC2ND\_HOT)

First order sensitivity temperature drift can be trimmed from -2000 to 2000 ppm/degC with TC1ST. The programming resolution is 40 ppm/degC.

Second order sensitivity temperature drift can be trimmed from -6 to 6 ppm/degC<sup>2</sup> with TC2ND. The programming resolution is 0.4/ppm/degC<sup>2</sup>. The second order can also be seen as third order correction since cold and hot sides are independently adjusted.

### 11.15 Offset temperature drift programming (OFFDRIFT\_COLD, OFFDRIFT\_HOT)

Offset temperature drift can be trimmed from -2.25 to +2.25 mV/degC. The programming resolution is 0.075 mV/degC. This first order correction is done independently for temperatures over 25degC and below 25degC.

## 11.16 Product Identification (MLXID, CSTID)

### MLXID

A 48-bit MLX ID is used to guarantee MLX traceability (lotnumber, wafer number, wafer position & option code) and is split up in 3x a 16 bit register (MLXID1, MLXID2 & MLXID3)  
The programmed option code is stored in MLXID3[2..0]:

| PSF Option Code <sup>(1)</sup><br>MLXID3[2..0] | Ordering Option Code <sup>(2)</sup> |
|--|-------------------------------------|
| 7  | CAL-001 / CAH-001 / CAH-021         |
| 6  | CAL-002 / CAH-002                   |
| 5  | CAL-003 / CAH-003                   |
| 4  | CAH-004 / CAH-104                   |

- (1) The option code mentioned in all 91206 related documentation (application notes, PSF and User Interface) refers to the PSF Option Code.
- (2) The Ordering Option Code mentioned on the page 1 of this datasheet refers to the Ordering Code, which defines the Chip version and the sensitivity range of the sensor

### CSTID

A 17-bit customer ID is available to create a dedicated traceability system

#### Self-diagnostic

The MLX91206 provides numerous self-diagnostic features. Those features increase the robustness of the IC functionality as it prevents the IC to provide erroneous output signal in case of internal or external failure modes.

| Error  | Action                                  | Effect on Outputs                  | Remarks   |
|--|---|------------------------------------|---|
| Calibration Data CRC Error (at power up and in normal working mode)                | Fault mode                              | High Impedance mode <sup>(1)</sup> | Pull down resistive load => Diag Low<br>Pull up resistive load => Diag High                     |
| Power On delay   |   | High Impedance mode <sup>(1)</sup> | 1 ms max in high impedance followed by settling   |
| Undervoltage Mode <sup>(4)</sup>   | IC is reset <sup>(7)</sup>              | High Impedance mode <sup>(1)</sup> | 300mV Hysteresis  |
| Overvoltage detection Mode 1 <sup>(5)</sup><br>(Threshold : min 7.9 V – max 9.5 V) | IC is switched off<br>(internal supply) | High Impedance mode <sup>(1)</sup> | I <sub>dd</sub> < 1mA<br>500 to 1500mV Hysteresis   |
| Overvoltage detection Mode 2 <sup>(6)</sup><br>(Threshold : min 6.8V – max 7.5V)   | IC is reset <sup>(7)</sup>              | High Impedance mode <sup>(1)</sup> | 100mV Hysteresis  |
| Broken Vss   | IC is switched off                      | High Impedance <sup>(2)</sup>      | With some restrictions on pull-up/pull-down resistors on OUT and TEMPOUT, see Chap. 6 , Table 3 |
| Broken Vdd   | IC is switched off                      | High Impedance <sup>(3)</sup>      | With some restrictions on pull-up/pull-down resistors on OUT, see Chap. 6 , Table 3             |

Table 22: Self diagnostic

- (1) Refer to Table 3: General electrical parameter, parameter High-impedance modes levels
- (2) Refer to Table 3: General electrical parameter, parameter BrokenVss Output Level
- (3) Refer to Table 3: General electrical parameter, parameter BrokenVdd Output Level
- (4) Refer to Table 3: General electrical parameter, parameter Under-voltage detection
- (5) Refer to Table 3: General electrical parameter, parameter Over-voltage detection mode 1
- (6) Refer to Table 3: General electrical parameter, parameter Over-voltage detection mode 2
- (7) The internal supply is regulated but the digital sequencer (hall element spinning) is stopped



## 12 Application information

### 12.1 Low current measurement up to ±2 A

Low currents can be measured with the MLX91206 by increasing the magnetic field via a coil around the sensor. The sensitivity (output voltage vs. current in coil) of the measurement will depend on the size of coil and number of turns. Additional sensitivity and increased immunity to external fields can be gained by adding a shield around the coil. The bobbin provides very high dielectric isolation making this a suitable solution for high voltage power supplies with relative low currents. The output should be scaled to obtain the maximum voltage for the highest current to be measured in order to obtain the best accuracy and resolution.

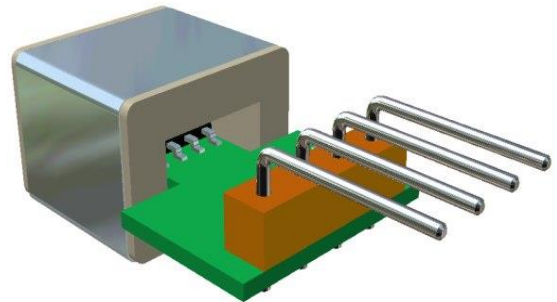

Figure 3: Low current application

### 12.2 Medium current up to ±30 A

With a single conductor located on the PCB, currents in the range of up to 30 amps can be measured. The sizing of the PCB trace needs to take into account the current handling capability and the total power dissipation. The PCB trace needs to be thick enough and wide enough to handle the RMS current continuously.

The differential output voltage for this configuration can be approximated by the following equation:

$$V_{out} = 35 \text{ mV/A} * I$$

For a current level of 30 A, the output will be approximately 1050 mV.

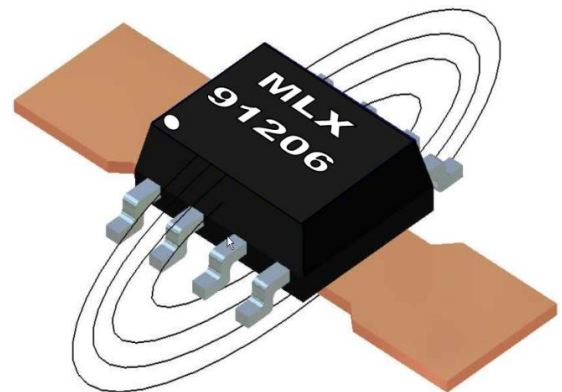

Figure 4: Medium current application

### 12.3 High current measurement up to ±600 A

Another method of measuring high currents on PCB's is to use a large thick gauge copper trace capable of carrying the current on the opposite side of the PCB. The MLX91206 should be located near the centre of the trace, however because the trace is wide, the output is less sensitive to location on the PCB. This configuration also has less sensitivity due to the distance and width of the conductor.



Figure 5: High current application

## 13 Recommended Application Diagrams

### 13.1 Resistor and capacitor values

All mentioned component values can have a  $\pm 20\%$  tolerance

| Part | Description                                      | Value                 | Unit       |
|------|--|-----------------------|------------|
| C1   | Supply capacitor, EMI, ESD                       | 10 - 220              | nF         |
| C2   | Regulator buffer capacitor, decoupling, EMI, ESD | 10 - 220              | nF         |
| C3   | Decoupling, EMI, ESD                             | 5 - 50                | nF         |
| C4   | Decoupling, EMI, ESD                             | 5 - 50 <sup>(1)</sup> | nF         |
| R1   | Pull up or pull down load resistor               | 10 - 30               | k $\Omega$ |

Table 23: Resistor and capacitor value

(1) When OUTMODE=0, which we do not advice in application, capacitor C4 should be 1nF or less.

### 13.2 Fast analog application, pull-down resistor for diagnostic low

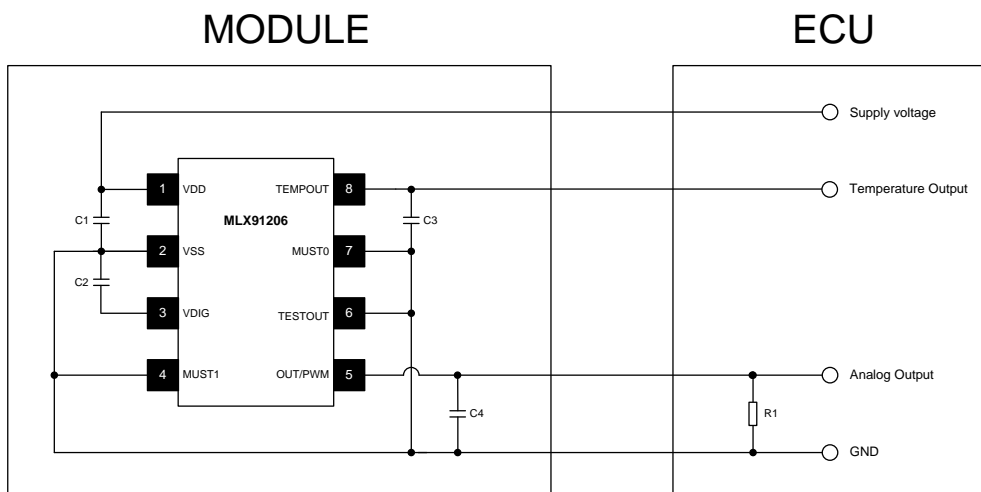

Figure 6: Fast analog application, Pull-down resistor

### 13.3 Fast analog application, pull-up resistor for diagnostic high

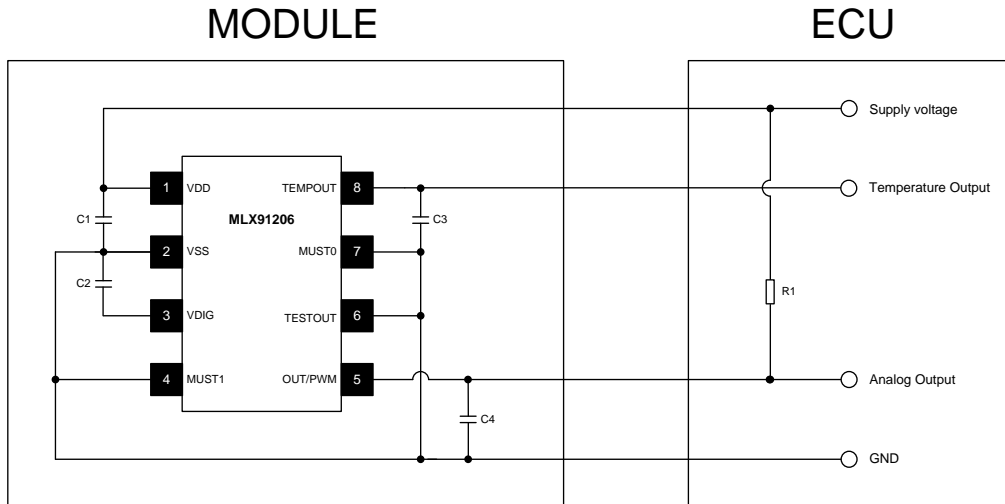

Figure 7: Fast analog application, Pull-up resistor

### 13.4 Robust PWM application, (pull-up load only)

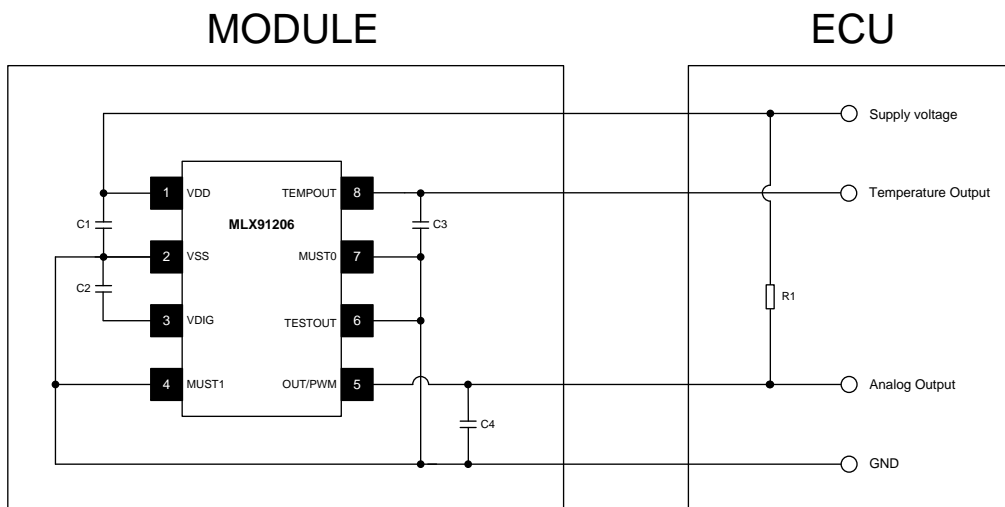

Figure 8: Robust PWM application with pull-up resistor

## **14 Standard information regarding manufacturability of Melexis products with different soldering processes**

Our products are classified and qualified regarding soldering technology, solderability and moisture sensitivity level according to following test methods:

### **Reflow Soldering SMD's (Surface Mount Devices)**

- IPC/JEDEC J-STD-020  
Moisture/Reflow Sensitivity Classification for Nonhermetic Solid State Surface Mount Devices (classification reflow profiles according to table 5-2)
- EIA/JEDEC JESD22-A113  
Preconditioning of Nonhermetic Surface Mount Devices Prior to Reliability Testing (reflow profiles according to table 2)

### **Wave Soldering SMD's (Surface Mount Devices) and THD's (Through Hole Devices)**

- EN60749-20  
Resistance of plastic- encapsulated SMD's to combined effect of moisture and soldering heat
- EIA/JEDEC JESD22-B106 and EN60749-15  
Resistance to soldering temperature for through-hole mounted devices

### **Iron Soldering THD's (Through Hole Devices)**

- EN60749-15  
Resistance to soldering temperature for through-hole mounted devices

### **Solderability SMD's (Surface Mount Devices) and THD's (Through Hole Devices)**

- EIA/JEDEC JESD22-B102 and EN60749-21  
Solderability

For all soldering technologies deviating from above mentioned standard conditions (regarding peak temperature, temperature gradient, temperature profile etc) additional classification and qualification tests have to be agreed upon with Melexis.

The application of Wave Soldering for SMD's is allowed only after consulting Melexis regarding assurance of adhesive strength between device and board.

Melexis is contributing to global environmental conservation by promoting **lead free** solutions. For more information on qualifications of **RoHS** compliant products (RoHS = European directive on the Restriction Of the use of certain Hazardous Substances) please visit the quality page on our website:  
<http://www.melexis.com/quality.aspx>

## **15 ESD Precautions**

Electronic semiconductor products are sensitive to Electro Static Discharge (ESD). Always observe Electro Static Discharge control procedures whenever handling semiconductor products.



**16.3 SOIC8 Hall plate position**

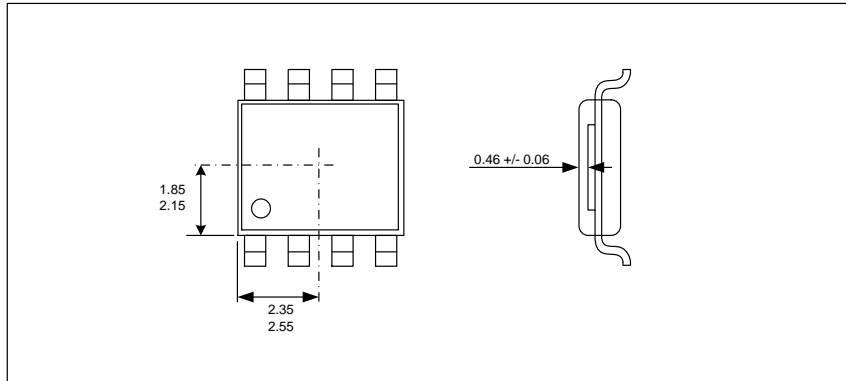

Figure 11: Hall Plate positioning

**16.4 IMC Position and sensors active measurement direction**

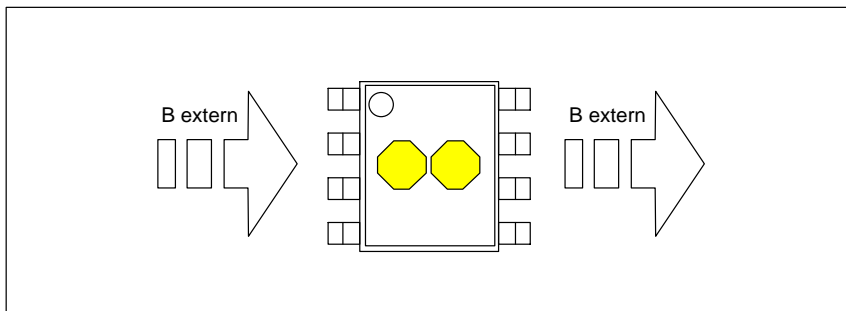

Figure 12: IMC position and geometry Low-Field version

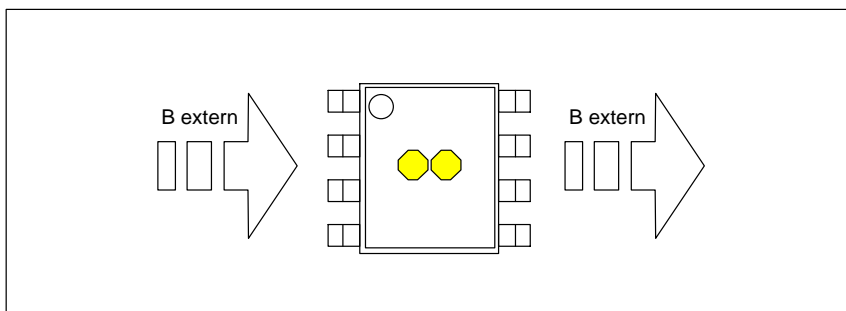

Figure 13: IMC position and geometry High-Field version

## **17 Related documents and tools**

### **17.1 Related documents**

- User Interface UI MLX91206 Description
- Product Specific Functions PSF MLX91206 Description
- PTC-04 Daughter Board DB-HALL-03 Data Sheet

The latest version of these documents is available on the Melexis Softdist platform. Please contact your local sales office to request an account (see contact details on page 25).

- Non intrusive current sensing with MLX91206 application note
- MLX91206 for PDU solutions application note
- Calibrating the MLX91206/MLX91207 application note
- Shielding for Triaxis current sensors application note

The latest version of these documents is available on the MLX91206 page on the Melexis website:

<http://www.melexis.com/Hall-Effect-Sensor-ICs/Special-Purpose-Hall-ICs/MLX91206-755.aspx>

### **17.2 Related software**

- MLX91206 Firmware
- MLX91206 Product Specific Functions (PSF)
- MLX91206 User Interface
- MLX PTC-04 Product Specific Functions
- MLX PTC-04 User Interface

The latest version of these pieces of software is available on the Melexis Softdist platform. Please contact your local sales office to request an account (see contact details on page 25).

### **17.3 Related hardware**

- PTC-04 Programmer for Melexis PTC devices
- PTC-04 Daughter Board DB-HALL-03 for MLX91206

## **18 Disclaimer**

Devices sold by Melexis are covered by the warranty and patent indemnification provisions appearing in its Term of Sale. Melexis makes no warranty, express, statutory, implied, or by description regarding the information set forth herein or regarding the freedom of the described devices from patent infringement. Melexis reserves the right to change specifications and prices at any time and without notice. Therefore, prior to designing this product into a system, it is necessary to check with Melexis for current information. This product is intended for use in normal commercial applications. Applications requiring extended temperature range, unusual environmental requirements, or high reliability applications, such as military, medical life-support or life-sustaining equipment are specifically not recommended without additional processing by Melexis for each application.

The information furnished by Melexis is believed to be correct and accurate. However, Melexis shall not be liable to recipient or any third party for any damages, including but not limited to personal injury, property damage, loss of profits, loss of use, interrupt of business or indirect, special incidental or consequential damages, of any kind, in connection with or arising out of the furnishing, performance or use of the technical data herein. No obligation or liability to recipient or any third party shall arise or flow out of Melexis' rendering of technical or other services.

© 2012 Melexis NV. All rights reserved.

For the latest version of this document, go to our website at  
**[www.melexis.com](http://www.melexis.com)**

Or for additional information contact Melexis Direct:

**Europe, Africa, Asia:**  
Phone: +32 1367 0495  
E-mail: [sales\\_europe@melexis.com](mailto:sales_europe@melexis.com)

**America:**  
Phone: +1 248 306 5400  
E-mail: [sales\\_usa@melexis.com](mailto:sales_usa@melexis.com)

ISO/TS 16949 and ISO14001 Certified



# Mouser Electronics

Authorized Distributor

Click to View Pricing, Inventory, Delivery & Lifecycle Information:

## Melexis:

[MLX91206LDC-CAL-003-RE](#) [MLX91206LDC-CAH-002-SP](#) [MLX91206LDC-CAH-003-RE](#) [MLX91206LDC-CAH-104-TU](#) [MLX91206LDC-CAL-001-SP](#) [MLX91206LDC-CAL-002-TU](#) [MLX91206LDC-CAH-001-SP](#) [MLX91206LDC-CAL-002-RE](#) [MLX91206LDC-CAH-002-TU](#) [MLX91206LDC-CAH-001-TU](#) [MLX91206LDC-CAL-003-TU](#) [MLX91206LDC-CAH-001-RE](#) [MLX91206LDC-CAH-004-TU](#) [MLX91206LDC-CAL-001-TU](#) [MLX91206LDC-CAL-003-SP](#) [MLX91206LDC-CAH-002-RE](#) [MLX91206LDC-CAH-004-SP](#) [MLX91206LDC-CAL-001-RE](#) [MLX91206LDC-CAH-003-TU](#) [MLX91206LDC-CAL-002-SP](#) [MLX91206LDC-CAH-003-SP](#) [MLX91206LDC-CAH-104-SP](#) [MLX91206LDC-CAH-004-RE](#) [MLX91206LDC-CAH-104-RE](#) [MLX91206LDC-CAH-021-RE](#) [MLX91206LDC-CAH-021-SP](#)