

Ultra-Small, 1.8V, μ Power, Rail-to-Rail I/O Op Amps

ABSOLUTE MAXIMUM RATINGS

Supply Voltage (V_{CC} to V_{EE}).....6V	8-Pin μ MAX (derate 4.10mW/°C above +70°C).....330mW
All Other Pins($V_{CC} + 0.3V$) to ($V_{EE} - 0.3V$)	8-Pin SO (derate 5.88mW/°C above +70°C)471mW
Current into IN_+ , IN_- $\pm 25mA$	14-Pin SO (derate 8.33mW/°C above +70°C)667mW
Output Short-Circuit Duration.....Continuous	14-Pin TSSOP (derate 6.3mW/°C above +70°C).....500mW
Continuous Power Dissipation ($T_A = +70^\circ C$)	Operating Temperature Range.....-40°C to +85°C
5-Pin SC70 (derate 2.5mW/°C above +70°C)200mW	Junction Temperature+150°C
5-Pin SOT23 (derate 7.1mW/°C above +70°C).....571mW	Storage Temperature Range-65°C to +150°C
8-Bump UCSP (derate 4.7mW/°C above +70°C).....379mW	Lead Temperature (soldering, 10s)+300°C

Stresses beyond those listed under "Absolute Maximum Ratings" may cause permanent damage to the device. These are stress ratings only, and functional operation of the device at these or any other conditions beyond those indicated in the operational sections of the specifications is not implied. Exposure to absolute maximum rating conditions for extended periods may affect device reliability.

ELECTRICAL CHARACTERISTICS

($V_{CC} = 1.8V$ to $5.5V$, $V_{EE} = V_{CM} = 0$, $V_{OUT} = V_{CC}/2$, $R_L = 100k\Omega$ connected to $V_{CC}/2$, $T_A = +25^\circ C$, unless otherwise noted.) (Note 1)

PARAMETER	SYMBOL	CONDITIONS	MIN	TYP	MAX	UNITS
Supply Voltage Range	V_{CC}	Inferred from PSRR test	1.8		5.5	V
Quiescent Supply Current (Per Amplifier)	I_Q	$V_{CC} = 1.8V$		100	210	μA
		$V_{CC} = 5.0V$		100	255	
Input Offset Voltage	V_{OS}	MAX4291		± 400	± 2500	μV
		MAX4292/MAX4294		± 200	± 1200	
Input Bias Current	I_B	$V_{CC} = 5.0V, 0 \leq V_{CM} \leq 5.0V$		± 15	± 60	nA
Input Offset Current	I_{OS}	$V_{CC} = 5.0V, 0 \leq V_{CM} \leq 5.0V$		± 1	± 7	nA
Differential Input Resistance	R_{IN}	$ V_{IN+} - V_{IN-} < 10mV$		0.75		$M\Omega$
Input Common-Mode Voltage Range	V_{CM}	Inferred from CMRR test	0		V_{CC}	V
Common-Mode Rejection Ratio	CMRR	Tested for $0 \leq V_{CM} \leq 1.8V$; $V_{CC} = 1.8V$	MAX4291	50	80	dB
			MAX4292/MAX4294	57	80	
		Tested for $0 \leq V_{CM} \leq 5.0V$, $V_{CC} = 5.0V$	MAX4291	60	90	dB
			MAX4292/MAX4294	66	90	
Power-Supply Rejection Ratio	PSRR		77	100		dB

Ultra-Small, 1.8V, μ Power, Rail-to-Rail I/O Op Amps

MAX4291/MAX4292/MAX4294

ELECTRICAL CHARACTERISTICS (continued)

($V_{CC} = 1.8V$ to $5.5V$, $V_{EE} = V_{CM} = 0$, $V_{OUT} = V_{CC}/2$, $R_L = 100k\Omega$ connected to $V_{CC}/2$, $T_A = +25^\circ C$, unless otherwise noted.)
(Note 1)

PARAMETER	SYMBOL	CONDITIONS		MIN	TYP	MAX	UNITS
Large-Signal Voltage Gain	A_V	$V_{CC} = 1.8V$	$R_L = 100k\Omega$, $0.02V \leq V_{OUT} \leq V_{CC} - 0.02V$	80	120		dB
			$R_L = 2k\Omega$, $0.1V \leq V_{OUT} \leq V_{CC} - 0.1V$	80	110		
		$V_{CC} = 5.0V$	$R_L = 100k\Omega$, $0.02V \leq V_{OUT} \leq V_{CC} - 0.02V$	80	130		
			$R_L = 2k\Omega$, $0.1V \leq V_{OUT} \leq V_{CC} - 0.1V$	80	120		
Output-Voltage Swing High	V_{OH}	Specified as $ V_{CC} - V_{OH} $	$R_L = 100k\Omega$ to $V_{CC}/2$		2	20	mV
			$R_L = 2k\Omega$ to $V_{CC}/2$		15	40	
Output-Voltage Swing Low	V_{OL}	Specified as $ V_{EE} - V_{OL} $	$R_L = 100k\Omega$ to $V_{CC}/2$		25	80	mV
			$R_L = 2k\Omega$ to $V_{CC}/2$		46	120	
Output Short-Circuit Current	$I_{OUT(SC)}$	Sourcing or sinking			20		mA
Channel-to-Channel Isolation	CH_{ISO}	Specified at $f = 10kHz$ (MAX4292/MAX4294 only)			83		dB
Gain-Bandwidth Product	$GBWP$				500		kHz
Phase Margin	ϕ_M				65		degrees
Gain Margin	GM				12		dB
Slew Rate	SR				0.2		V/ μs
Input Voltage-Noise Density	e_n	$f = 10kHz$			70		nV/ \sqrt{Hz}
Input Current-Noise Density	i_n	$f = 10kHz$			0.05		pA/ \sqrt{Hz}
Capacitive-Load Stability		$AV_{CL} = 1V/V$, no sustained oscillations			100		pF

ELECTRICAL CHARACTERISTICS

($V_{CC} = 1.8V$ to $5.5V$, $V_{EE} = V_{CM} = 0$, $V_{OUT} = V_{CC}/2$, $R_L = 100k\Omega$ connected to $V_{CC}/2$, $T_A = T_{MIN}$ to T_{MAX} , unless otherwise noted.)
(Note 1)

PARAMETER	SYMBOL	CONDITIONS	MIN	TYP	MAX	UNITS
Supply-Voltage Range	V_{CC}	Inferred from PSRR test	1.8		5.5	V
Quiescent Supply Current (Per Amplifier)	I_Q	$V_{CC} = 1.8V$			240	μA
		$V_{CC} = 5.0V$			270	
Input Offset Voltage	V_{OS}	MAX4291			± 3000	μV
		MAX4292/MAX4294			± 2000	

Ultra-Small, 1.8V, μ Power, Rail-to-Rail I/O Op Amps

ELECTRICAL CHARACTERISTICS (continued)

($V_{CC} = 1.8V$ to $5.5V$, $V_{EE} = V_{CM} = 0$, $V_{OUT} = V_{CC}/2$, $R_L = 100k\Omega$ connected to $V_{CC}/2$, $T_A = T_{MIN}$ to T_{MAX} , unless otherwise noted.)
(Note 1)

PARAMETER	SYMBOL	CONDITIONS		MIN	TYP	MAX	UNITS
Input Offset Voltage Drift	TCV _{OS}				1.2		$\mu V/^\circ C$
Input Bias Current	I _B	$V_{CC} = 5.0V$, $0 \leq V_{CM} \leq 5.0V$				± 90	nA
Input Offset Current	I _{OS}	$V_{CC} = 5.0V$, $0 \leq V_{CM} \leq 5.0V$				± 10	nA
Input Common-Mode Voltage Range	V _{CM}	Inferred from CMRR test		0		V _{CC}	V
Common-Mode Rejection Ratio	CMRR	Tested for $0 \leq V_{CM} \leq 1.8V$, $V_{CC} = 1.8V$	MAX4291	50			dB
			MAX4292/MAX4294	53			
		Tested for $0 \leq V_{CM} \leq 5.0V$, $V_{CC} = 5.0V$	MAX4291	60		dB	
			MAX4292/MAX4294	62			
Power-Supply Rejection Ratio	PSRR			75			dB
Large-Signal Voltage Gain	A _v	V _{CC} = 1.8V	R _L = 100k Ω , $0.02V \leq V_{OUT} \leq V_{CC} - 0.02V$	80			dB
			R _L = 2k Ω , $0.1V \leq V_{OUT} \leq V_{CC} - 0.1V$	80			
		V _{CC} = 5.0V	R _L = 100k Ω , $0.02V \leq V_{OUT} \leq V_{CC} - 0.02V$	80			
			R _L = 2k Ω , $0.1V \leq V_{OUT} \leq V_{CC} - 0.1V$	80			
Output-Voltage Swing High	V _{OH}	Specified as V _{CC} - V _{OH}	R _L = 100k Ω to $V_{CC}/2$			20	mV
			R _L = 2k Ω to $V_{CC}/2$			40	
Output-Voltage Swing Low	V _{OL}	Specified as V _{EE} - V _{OL}	R _L = 100k Ω to $V_{CC}/2$			80	mV
			R _L = 2k Ω to $V_{CC}/2$			120	

Note 1: All devices are 100% tested at $T_A = +25^\circ C$. All temperature limits are guaranteed by design.

Ultra-Small, 1.8V, μ Power, Rail-to-Rail I/O Op Amps

Typical Operating Characteristics

($V_{CC} = 2.4V$, $V_{EE} = V_{CM} = 0$, $V_{OUT} = V_{CC}/2$, no load, $T_A = +25^\circ C$, unless otherwise noted.)

MAX4291/MAX4292/MAX4294

SUPPLY CURRENT PER AMPLIFIER vs. TEMPERATURE

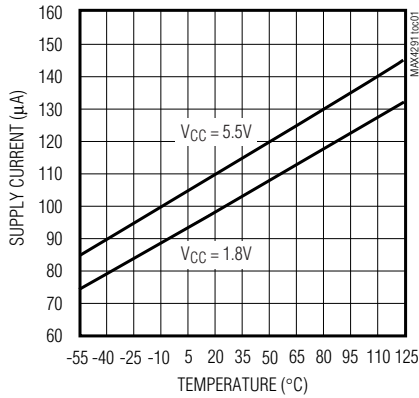

MINIMUM OPERATING VOLTAGE vs. TEMPERATURE (PSRR \geq 80dB)

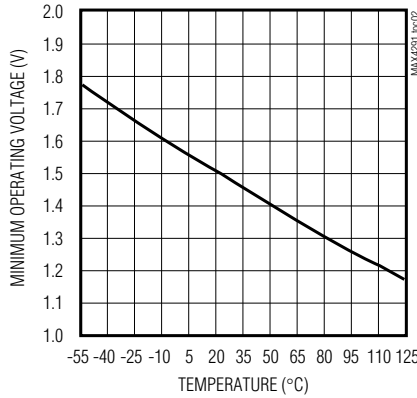

INPUT OFFSET VOLTAGE vs. TEMPERATURE

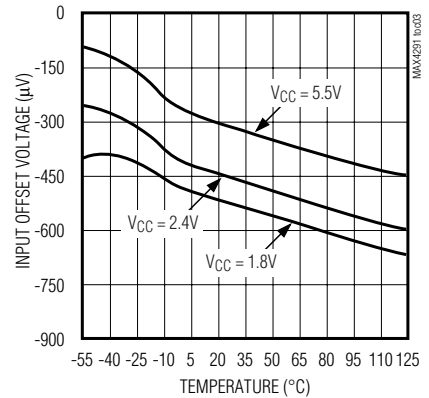

INPUT BIAS CURRENT vs. TEMPERATURE

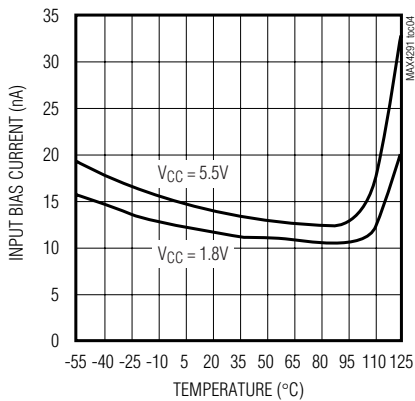

INPUT BIAS CURRENT vs. COMMON-MODE VOLTAGE ($V_{CC} = 1.8V$)

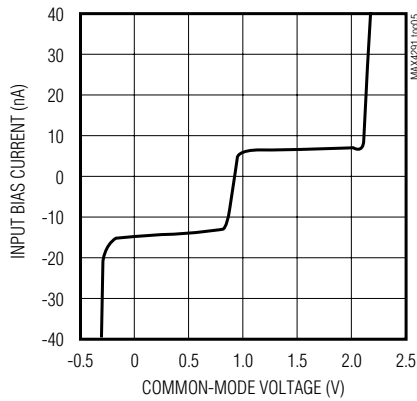

INPUT BIAS CURRENT vs. COMMON-MODE VOLTAGE ($V_{CC} = 5.5V$)

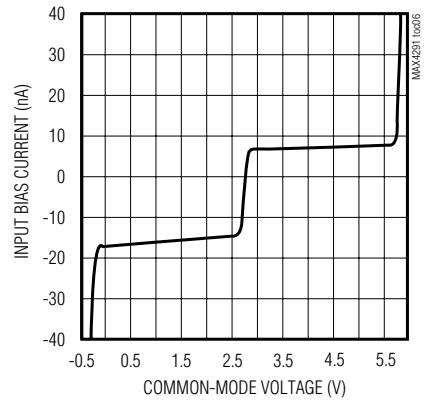

OUTPUT VOLTAGE SWING vs. TEMPERATURE ($R_L = 100k\Omega$ TO $V_{CC}/2$)

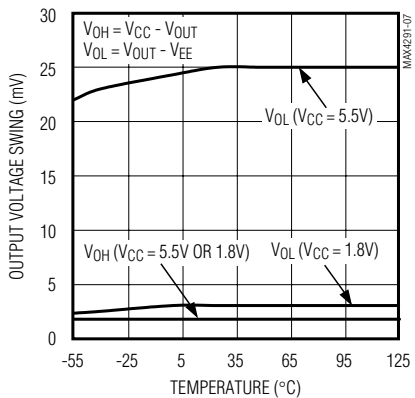

OUTPUT VOLTAGE SWING vs. TEMPERATURE ($R_L = 2k\Omega$ TO $V_{CC}/2$)

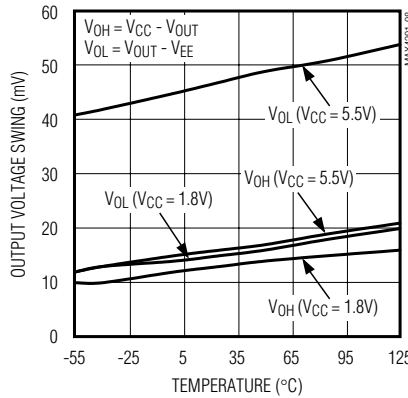

COMMON-MODE REJECTION RATIO vs. TEMPERATURE

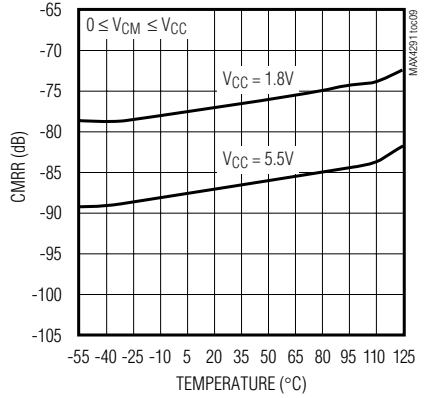

Ultra-Small, 1.8V, μ Power, Rail-to-Rail I/O Op Amps

Typical Operating Characteristics (continued)

($V_{CC} = 2.4V$, $V_{EE} = V_{CM} = 0$, $V_{OUT} = V_{CC}/2$, no load, $T_A = +25^\circ C$, unless otherwise noted.)

OPEN-LOOP GAIN vs. OUTPUT SWING LOW
($V_{CC} = 1.8V$, R_L CONNECTED TO V_{CC})

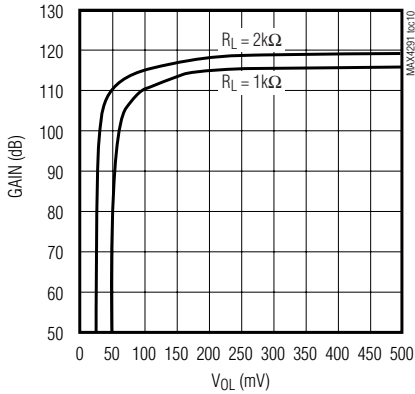

OPEN-LOOP GAIN vs. OUTPUT SWING HIGH
($V_{CC} = 1.8V$, R_L CONNECTED TO V_{EE})

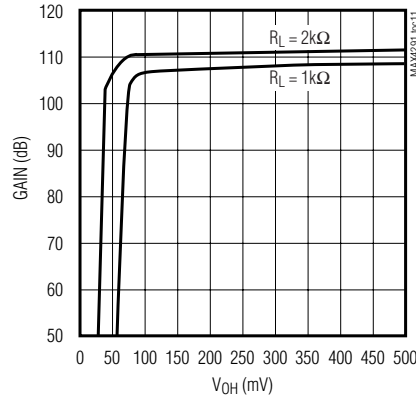

OPEN-LOOP GAIN vs. OUTPUT SWING LOW
($V_{CC} = 5.5V$, R_L CONNECTED TO V_{CC})

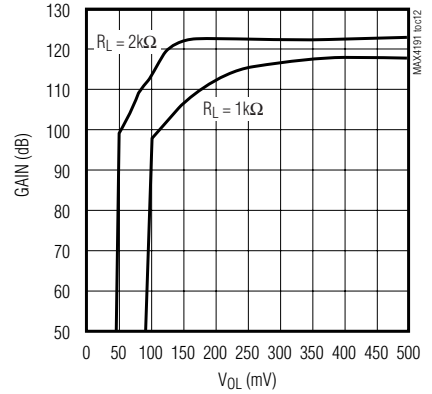

OPEN-LOOP GAIN vs. OUTPUT SWING HIGH
($V_{CC} = 5.5V$, R_L CONNECTED TO V_{EE})

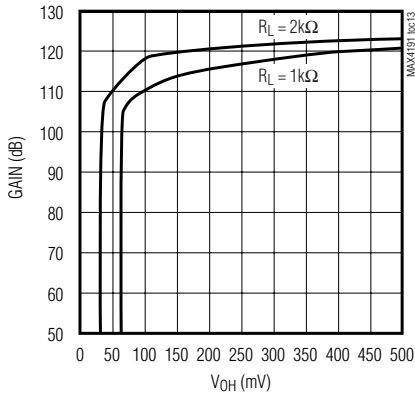

OPEN-LOOP GAIN vs. TEMPERATURE

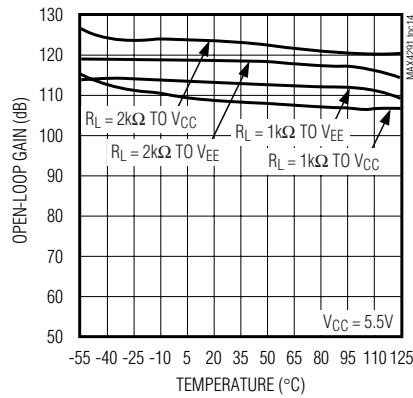

MAX4292/MAX4294
CROSSTALK vs. FREQUENCY

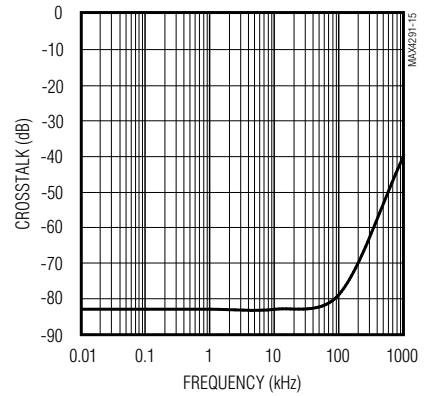

GAIN AND PHASE vs. FREQUENCY
($C_L = 0$)

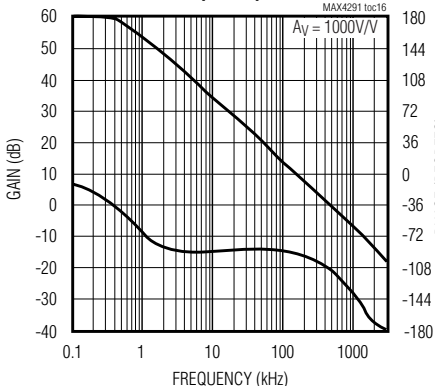

GAIN AND PHASE vs. FREQUENCY
($C_L = 100pF$)

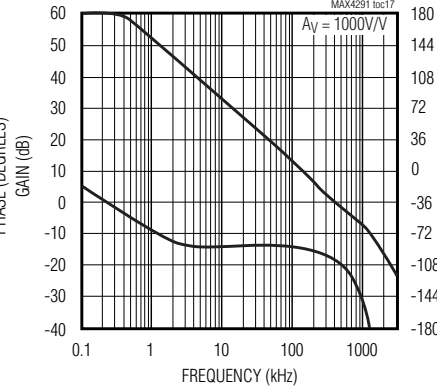

TOTAL HARMONIC DISTORTION PLUS NOISE vs. FREQUENCY

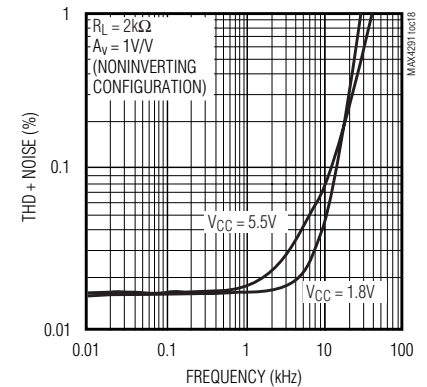

Ultra-Small, 1.8V, μ Power, Rail-to-Rail I/O Op Amps

Typical Operating Characteristics (continued)

($V_{CC} = 2.4V$, $V_{EE} = V_{CM} = 0$, $V_{OUT} = V_{CC}/2$, no load, $T_A = +25^\circ C$, unless otherwise noted.)

MAX4291/MAX4292/MAX4294

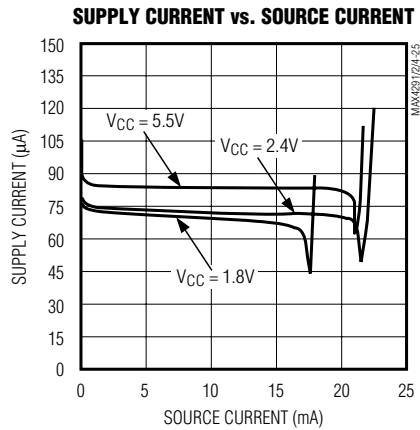
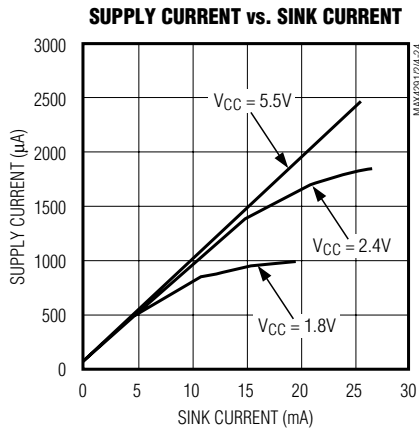
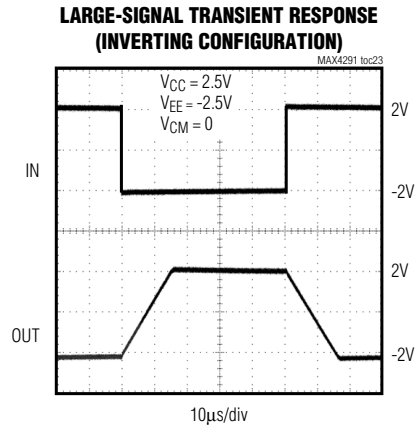
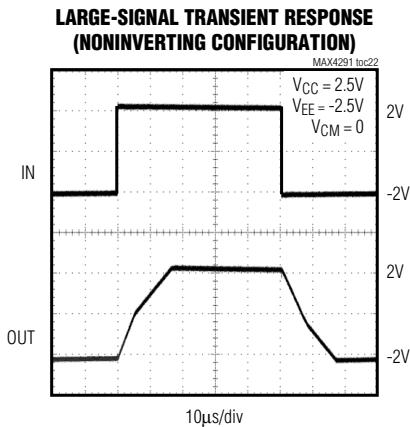
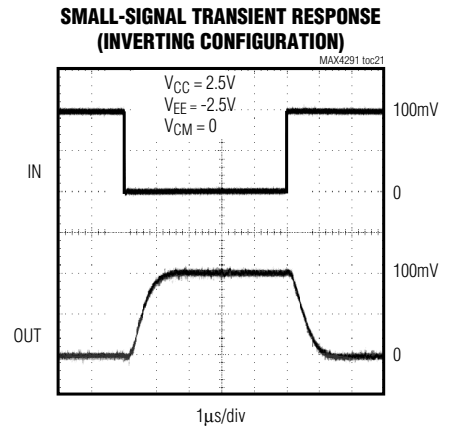
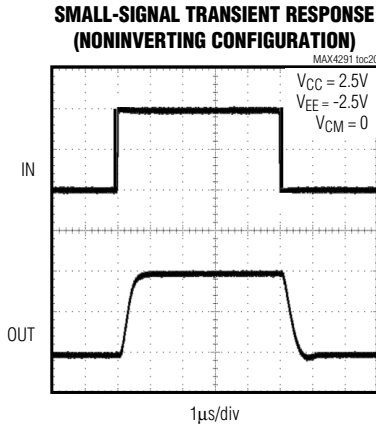
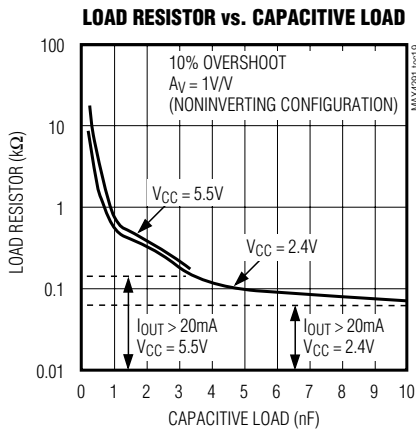

Ultra-Small, 1.8V, μ Power, Rail-to-Rail I/O Op Amps

Pin Description

PIN				NAME	FUNCTION
MAX4291	MAX4292		MAX4294		
	μ MAX/SO	UCSP			
1	—	—	—	IN+	Noninverting Input
2	4	C2	11	VEE	Negative Supply. Connect to ground for single-supply operation.
3	—	—	—	IN-	Inverting Input
4	—	—	—	OUT	Amplifier Output
5	8	A2	4	VCC	Positive Supply
—	1, 7	A1, A3	1, 7	OUTA, OUTB	Outputs for Amplifiers A and B
—	2, 6	B1, B3	2, 6	INA-, INB-	Inverting Inputs to Amplifiers A and B
—	3, 5	C1, C3	3, 5	INA+, INB+	Noninverting Inputs to Amplifiers A and B
—	—	—	8, 14	OUTC, OUTD	Outputs for Amplifiers C and D
—	—	—	9, 13	INC-, IND-	Inverting Inputs to Amplifiers C and D
—	—	—	10, 12	INC+, IND+	Noninverting Inputs to Amplifiers C and D

Detailed Description

Rail-to-Rail Input Stage

The MAX4291/MAX4292/MAX4294 have rail-to-rail inputs and output stages that are specifically designed for low-voltage, single-supply operation in the smallest package possible. The input stage consists of separate NPN and PNP differential stages, which operate together to provide a common-mode range extending to both supply rails. The crossover region of these two pairs occurs halfway between VCC and VEE. The input offset voltage is typically $\pm 200\mu\text{V}$ (MAX4292/MAX4294). Low operating supply voltage, low supply current, rail-to-rail common-mode input range, and rail-to-rail outputs make this family of operational amplifiers (op amps) an excellent choice for precision or general-purpose, low-voltage, battery-powered systems.

Since the input stage consists of NPN and PNP pairs, the input bias current changes polarity as the common-mode voltage passes through the crossover region. Match the effective impedance seen by each input to reduce the offset error caused by input bias currents flowing through external source impedances (Figures 1a and 1b).

The combination of high-source impedance plus input capacitance (amplifier input capacitance plus stray

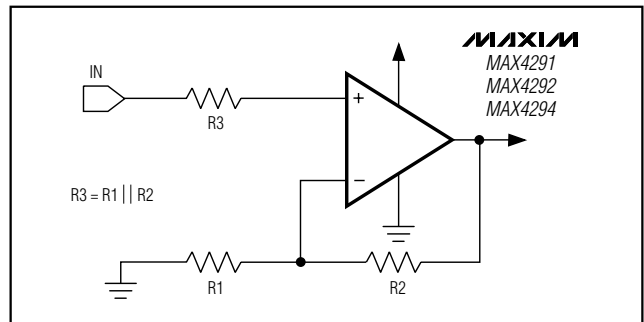

Figure 1a. Minimizing Offset Error Due to Input Bias Current (Noninverting)

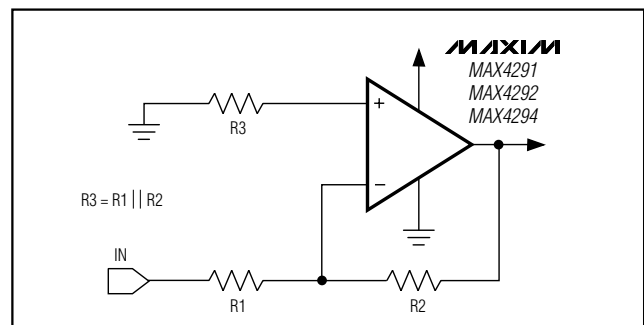

Figure 1b. Minimizing Offset Error Due to Input Bias Current (Inverting)

Ultra-Small, 1.8V, μ Power, Rail-to-Rail I/O Op Amps

Table 1. MAX4291 Characteristics with Typical Battery Systems

BATTERY TYPE	RECHARGE-ABLE	V _{FRESH} (V)	V _{END-OF-LIFE} (V)	CAPACITY, AA SIZE (mA-h)	MAX4291 OPERATING TIME IN NORMAL MODE (h)
Alkaline (2 cells)	No	3.0	1.8	2000	20,000
Nickel-Cadmium (2 cells)	Yes	2.4	1.8	750	7500
Lithium-Ion (1 cell)	Yes	3.5	2.7	1000	10,000
Nickel-Metal-Hydride (2 cells)	Yes	2.4	1.8	1000	10,000

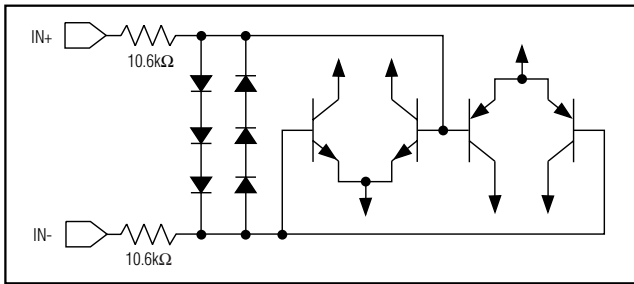

Figure 2. Input Protection Circuit

capacitance) creates a parasitic pole that produces an underdamped signal response. Reducing input capacitance or placing a small capacitor across the feedback resistor improves response in this case.

The MAX4291/MAX4292/MAX4294 family's inputs are protected from large differential input voltages by internal 10.6k Ω series resistors and back-to-back triple-diode stacks across the inputs (Figure 2). For differential input voltages (much less than 1.8V), input resistance is typically 0.75M Ω . For differential input voltages greater than 1.8V, input resistance is around 21.2k Ω , and the input bias current can be approximated by the following equation:

$$I_{BIAS} = \frac{(V_{DIFF} - 1.8V)}{21.2k\Omega}$$

In the region where the differential input voltage approaches 1.8V, the input resistance decreases exponentially from 0.75M Ω to 21.2k Ω as the diode block begins to conduct. Conversely, the bias current increases with the same curve.

In unity-gain configuration, high slew-rate input signals may capacitively couple to the output through the triple-diode stacks.

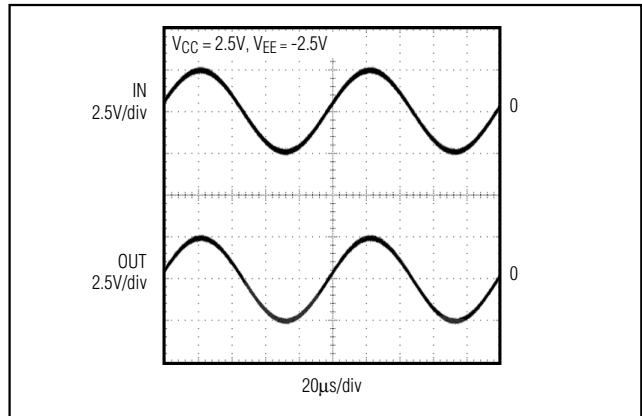

Figure 3. Rail-to-Rail Input/Output Voltage Range

Rail-to-Rail Output Stage

The MAX4291/MAX4292/MAX4294 output stage can drive up to a 2k Ω load and still swing to within 46mV of the rails. Figure 3 shows the output-voltage swing of a MAX4291 configured as a unity-gain buffer, powered from a $\pm 2.5V$ supply. The output for this setup typically swings from ($V_{EE} + 25mV$) to ($V_{CC} - 2mV$) with a 100k Ω load.

Applications Information

Power-Supply Considerations

The MAX4291/MAX4292/MAX4294 operate from a single 1.8V to 5.5V supply (or dual $\pm 0.9V$ to $\pm 2.75V$ supplies) and consume only 100 μA of supply current per amplifier. A high power-supply rejection ratio of 100dB allows the amplifiers to be powered directly off a decaying battery voltage, simplifying design and extending battery life.

The MAX4291/MAX4292/MAX4294 are ideally suited for use with most battery-powered systems. Table 1 lists a

Ultra-Small, 1.8V, μ Power, Rail-to-Rail I/O Op Amps

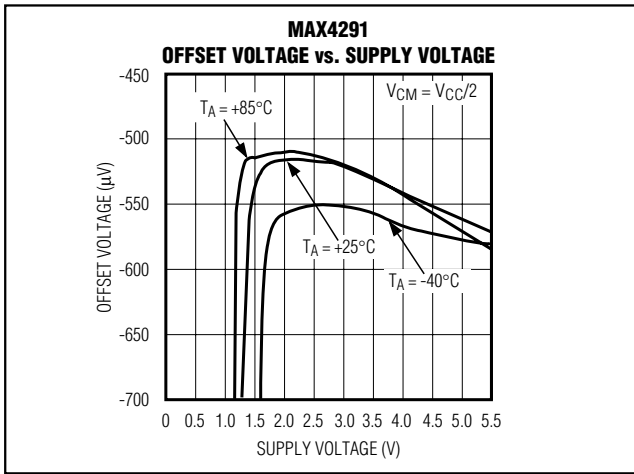

Figure 4. Offset Voltage vs. Supply Voltage

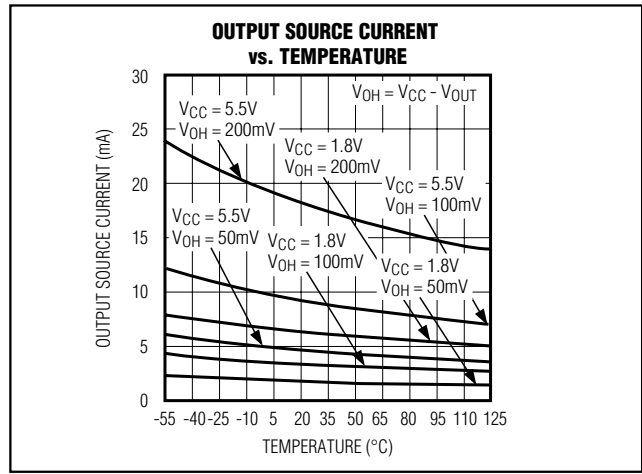

Figure 6a. Output Source Current vs. Temperature

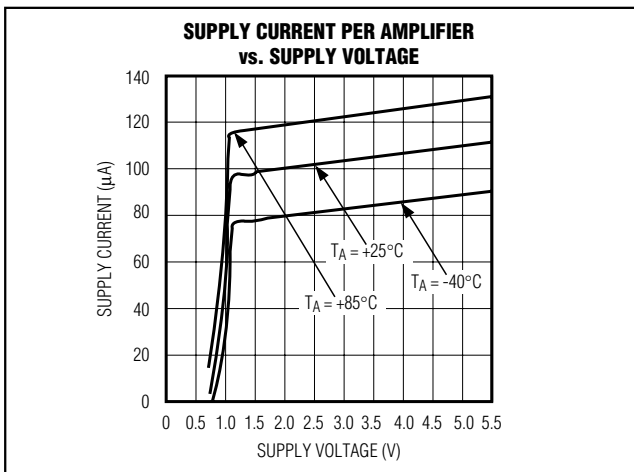

Figure 5. Supply Current per Amplifier vs. Supply Voltage

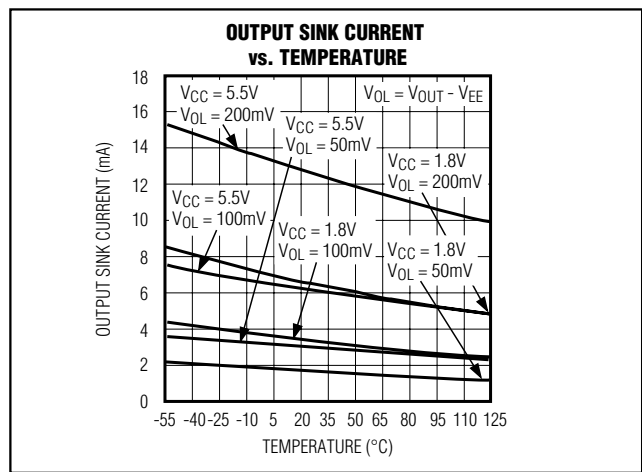

Figure 6b. Output Sink Current vs. Temperature

variety of typical battery types showing voltage when fresh, voltage at end-of-life, capacity, and approximate operating time from a MAX4291 (assuming nominal conditions).

Although the amplifiers are fully guaranteed over temperature for operation down to a 1.8V single supply, even lower voltage operation is possible in practice. Figures 4 and 5 show the offset voltage and supply current as a function of supply voltage and temperature.

Load-Driving Capability

The MAX4291/MAX4292/MAX4294 are fully guaranteed over temperature and supply voltage range to drive a maximum resistive load of $2k\Omega$ to $V_{CC}/2$, although heavier loads can be driven in many applications. The rail-to-rail output stage of the amplifier can be modeled

as a current source when driving the load toward V_{CC} , and as a current sink when driving the load toward V_{EE} . The limit of this current source/sink varies with supply voltage, ambient temperature, and lot-to-lot variations of the units.

Figures 6a and 6b show the typical current source and sink capabilities of the MAX4291/MAX4292/MAX4294 family as a function of supply voltage and ambient temperature. The contours on the graph depict the output current value, based on driving the output voltage to within 50mV, 100mV, and 200mV of either power-supply rail.

For example, a MAX4291 running from a single 1.8V supply, operating at $T_A = +25^\circ\text{C}$ can source 3.5mA to

Ultra-Small, 1.8V, μ Power, Rail-to-Rail I/O Op Amps

MAX4291/MAX4292/MAX4294

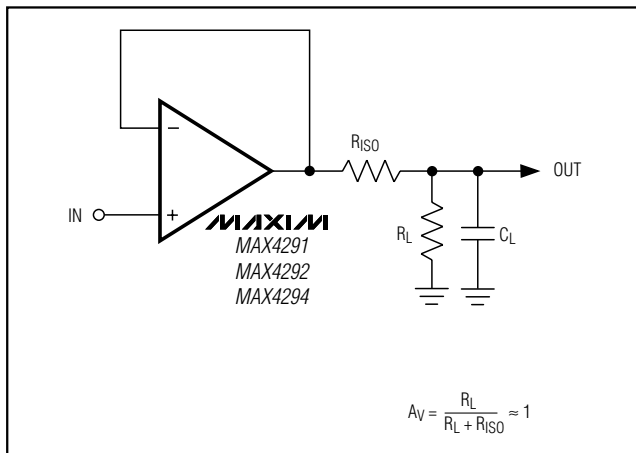

Figure 7a. Using a Resistor to Isolate a Capacitive Load from the Op Amp

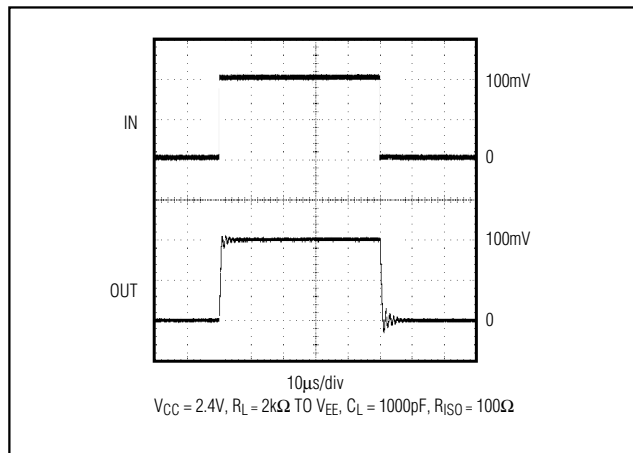

Figure 7c. Pulse Response with Isolating Resistor (100 Ω)

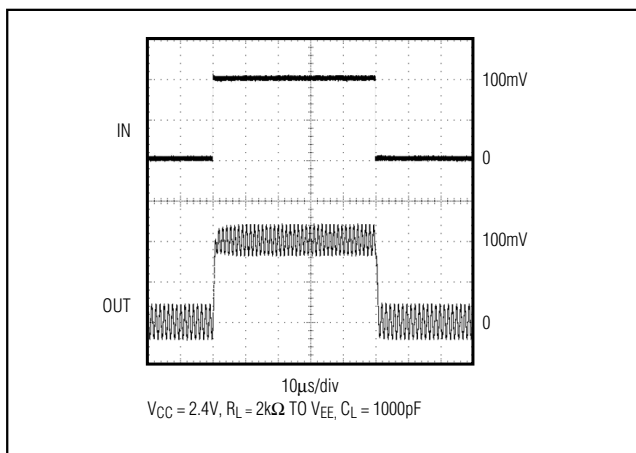

Figure 7b. Pulse Response Without Isolating Resistor

resistor between the output and the capacitive load (Figure 7). Note that this alternative results in a loss of gain accuracy because R_{ISO} forms a voltage divider with the load resistor.

Power-Supply Bypassing and Layout

The MAX4291/MAX4292/MAX4294 family operates from either a single 1.8V to 5.5V supply or dual $\pm 0.9V$ to $\pm 2.75V$ supplies. For single-supply operation, bypass the power supply with a 100nF capacitor to V_{EE} (in this case GND). For dual-supply operation, both the V_{CC} and the V_{EE} supplies should be bypassed to ground with separate 100nF capacitors.

Good PC board layout techniques optimize performance by decreasing the amount of stray capacitance at the op amp's inputs and output. To decrease stray capacitance, minimize trace lengths and widths by placing external components as close as possible to the op amp. Surface-mount components are an excellent choice.

Using the MAX4291/MAX4292/MAX4294 as Comparators

Although optimized for use as operational amplifiers, the MAX4291/MAX4292/MAX4294 can also be used as rail-to-rail I/O comparators. Typical propagation delay depends on the input overdrive voltage, as shown in Figure 8. External hysteresis can be used to minimize the risk of output oscillation. The positive feedback circuit, shown in Figure 9, causes the input threshold to change when the output voltage changes state. The two thresholds create a hysteresis band that can be calculated by the following equations:

within 100mV of V_{CC} and is capable of driving a 485 Ω load resistor to V_{EE} :

$$R_L = \frac{(1.8V - 0.1V)}{3.5mA} = 485\Omega \text{ to } V_{EE}$$

The same application can drive a 220k Ω load resistor when terminated in $V_{CC}/2$ (0.9V in this case).

Driving Capacitive Loads

The MAX4291/MAX4292/MAX4294 are unity-gain stable for loads up to 100pF (see the Load Resistor vs. Capacitive Load graph in the *Typical Operating Characteristics*). Applications that require greater capacitive-drive capability should use an isolation

Ultra-Small, 1.8V, μ Power, Rail-to-Rail I/O Op Amps

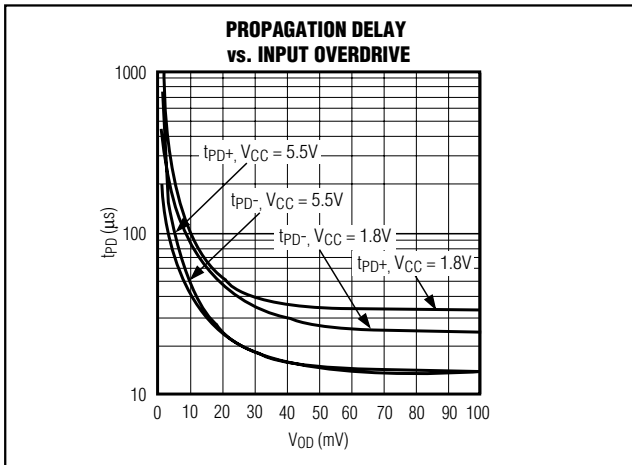

Figure 8. Propagation Delay vs. Input Overdrive

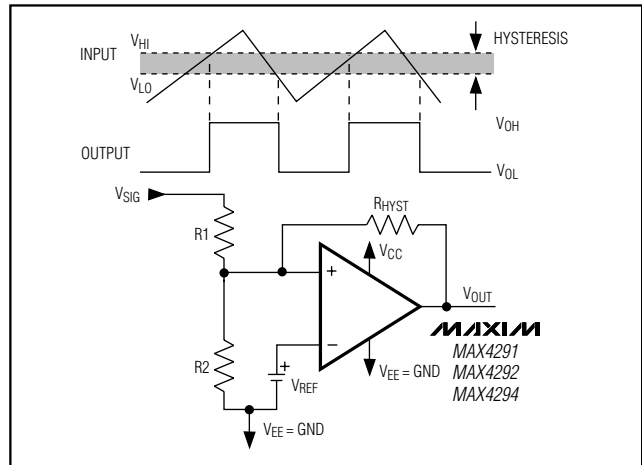

Figure 9. Hysteresis Comparator Circuit

$$V_{HYST} = V_{HI} - V_{LO}$$

$$V_{HI} = \left[1 + \frac{R1}{R2} + \frac{R1}{R_{HYST}} \right] V_{REF}$$

$$V_{LO} = V_{HI} - \left(\frac{R1}{R_{HYST}} \right) V_{CC}$$

When the output of the comparator is low, the supply current increases. The output stage has biasing circuitry to monitor the output current. When the amplifier is used as a comparator, the output stage is overdriven and the current through the biasing circuitry increases to maximum. For the MAX4291, typical supply currents increase to 1.5mA with $V_{CC} = 1.8V$ and to 9mA when $V_{CC} = 5.0V$ (Figure 10).

Using the MAX4291/MAX4292/MAX4294 as Low-Power Current Monitors

The MAX4291/MAX4292/MAX4294 are ideal for applications powered from a two-cell battery stack. Figure 11 shows an application circuit in which the MAX4291 is used for monitoring the current of a two-cell battery stack. In this circuit, a current load is applied, and the voltage drop at the battery terminal is sensed.

The voltage on the load side of the battery stack is equal to the voltage at the emitter of Q1 due to the feedback loop containing the op amp. As the load current increases, the voltage drop across R1 and R2 increases. Thus, R2 provides a fraction of the load current (set by the ratio of R1 and R2) that flows into the

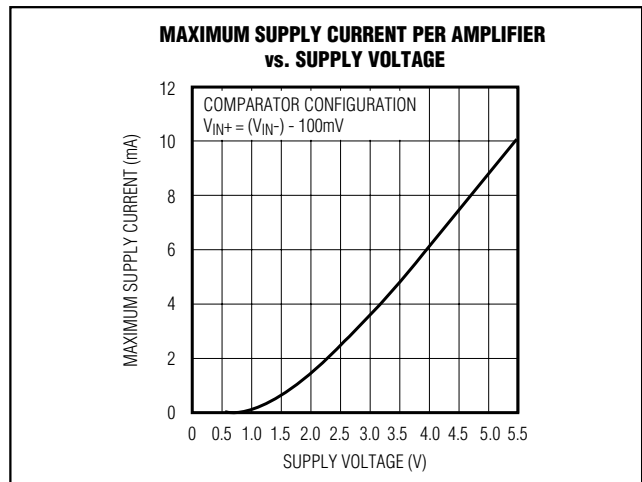

Figure 10. Maximum Supply Current per Amplifier vs. Supply Voltage

emitter of the PNP transistor. Neglecting PNP base current, this current flows into R3, producing a ground-referenced voltage proportional to the load current. To minimize errors, scale R1 to give a voltage drop that is large enough in comparison to the op amp's V_{OS} .

Calculate the output voltage of the application using the following equation:

$$V_{OUT} = \left[I_{LOAD} \times \left(\frac{R1}{R2} \right) \right] \times R3$$

Ultra-Small, 1.8V, μ Power, Rail-to-Rail I/O Op Amps

MAX4291/MAX4292/MAX4294

For a 1V output and a current load of 50mA, the choice of resistors can be $R1 = 2\Omega$, $R2 = 100k\Omega$, and $R3 = 1M\Omega$.

UCSP Information

Layout Issues

Design the layout for the IC to be as compact as possible to minimize parasitics. The UCSP uses a bump pitch of 0.5mm (19.7mil) and bump diameter of 0.3 (~12mil). Therefore, lay out the solder-pad spacing on 0.5mm (19.7mil) centers, using a pad size of 0.25mm (~10mil) and a solder mask opening of 0.33mm (13mil). Round or square pads are permissible. Connect multiple vias from the ground plane as close to the ground pins as possible.

Install capacitors as close as possible to the IC supply voltage pin. Place the ground end of these capacitors near the IC GND pins to provide a low-impedance return path for the signal current.

Prototype Chip Installation

Alignment keys on the PC board, around the area where the chip is located, will be helpful in the prototype assembly process. It is better to align the chip on the board before any other components are placed, and then place the board on a hot plate or hot surface until the solder starts melting. Remove the board from the hot plate without disturbing the position of the chip and let it cool down to room temperature before processing the board further.

UCSP Reliability

The UCSP represents a unique packaging form factor that may not perform as well as a packaged product through traditional mechanical reliability tests. UCSP reliability is integrally linked to the user's assembly methods, circuit board material, and usage environment. The user should closely review these areas when considering use of a UCSP.

Performance through operating-life test and moisture resistance remains uncompromised. The wafer-fabrication process primarily determines the performance. Mechanical stress performance is a greater consideration for UCSPs. UCSPs are attached through direct solder contact to the user's PC board, foregoing the inherent stress relief of a packaged product lead frame. Solder-joint contact integrity must be considered. Comprehensive reliability tests have been performed and are available upon request. In conclusion, the UCSP performs reliably through environmental stresses.

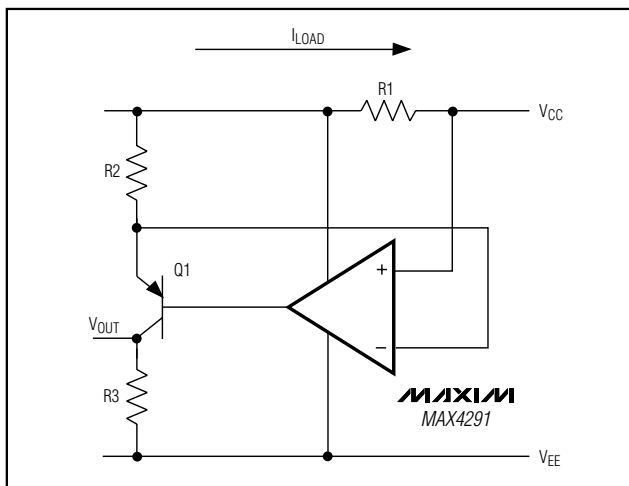
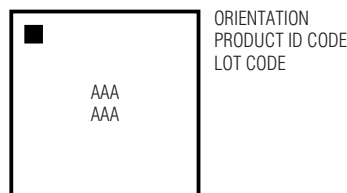

Figure 11. Current Monitor for a 2-Cell Battery Stack

Marking Information



Ultra-Small, 1.8V, μ Power, Rail-to-Rail I/O Op Amps

Pin Configurations (continued)

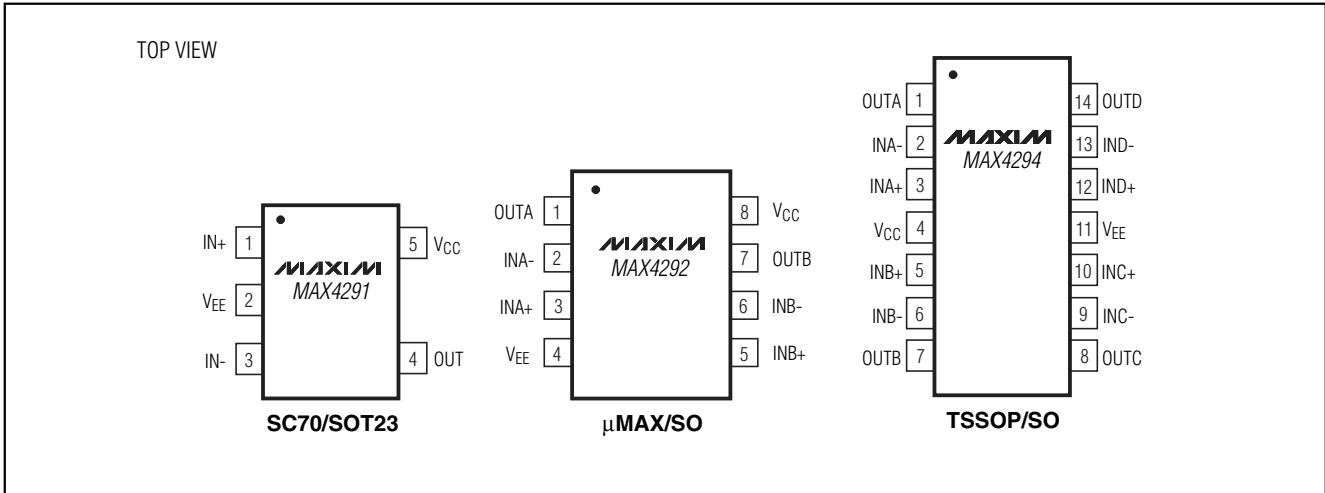

Chip Information

MAX4291 TRANSISTOR COUNT: 149
 MAX4292 TRANSISTOR COUNT: 356
 MAX4294 TRANSISTOR COUNT: 747
 PROCESS: BiCMOS

Ultra-Small, 1.8V, μ Power, Rail-to-Rail I/O Op Amps

Package Information

(The package drawing(s) in this data sheet may not reflect the most current specifications. For the latest package outline information, go to www.maxim-ic.com/packages.)

MAX4291/MAX4292/MAX4294

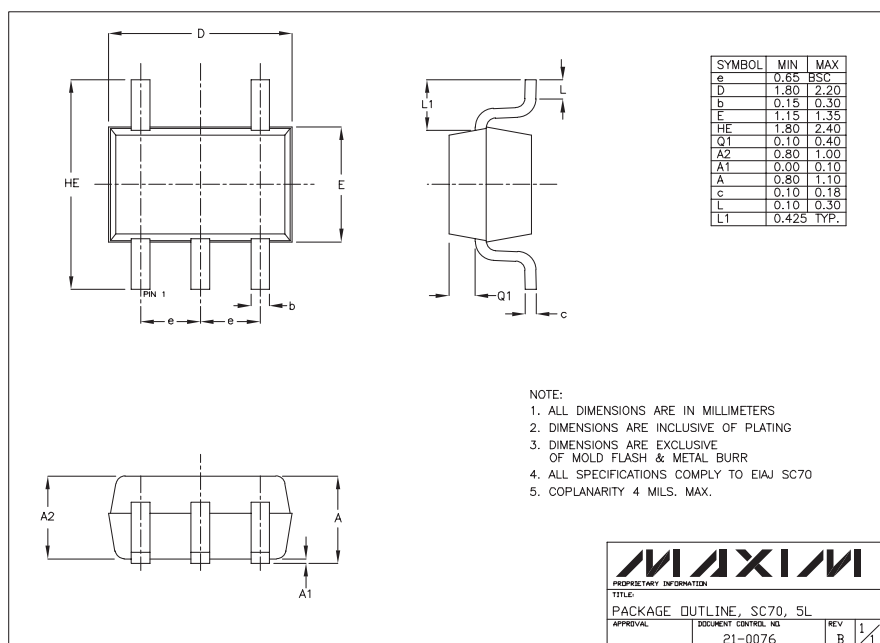
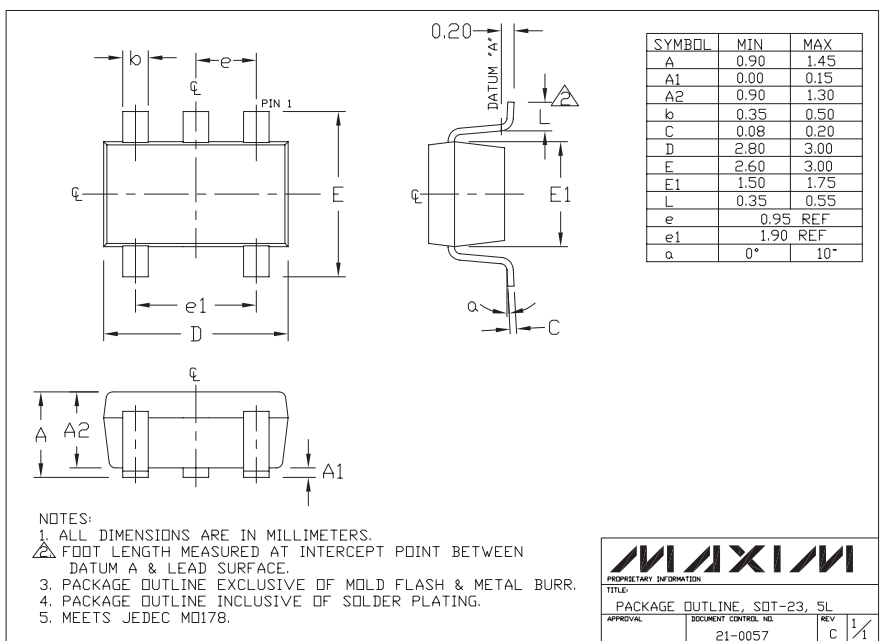

Ultra-Small, 1.8V, μ Power, Rail-to-Rail I/O Op Amps

Package Information (continued)

(The package drawing(s) in this data sheet may not reflect the most current specifications. For the latest package outline information, go to www.maxim-ic.com/packages.)

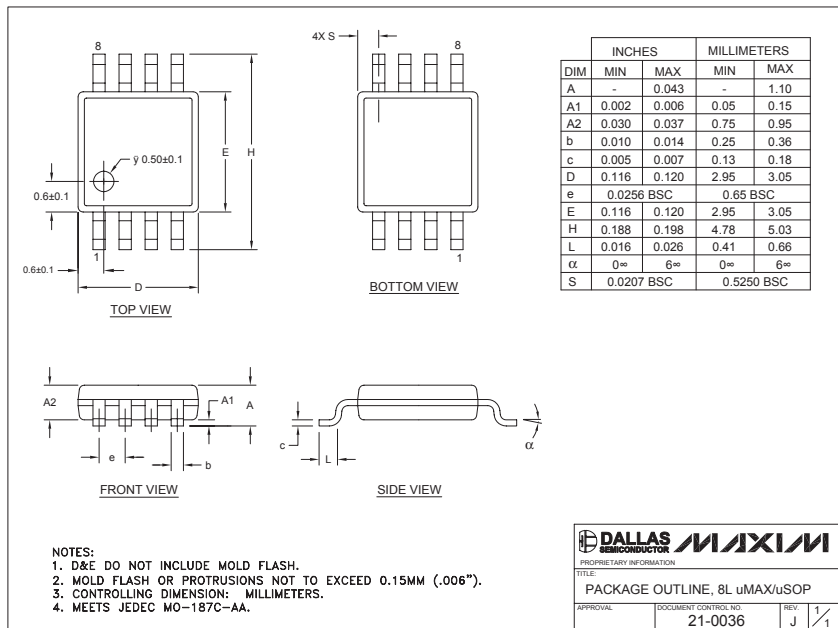

Note: The MAX4292 does not have an exposed pad.

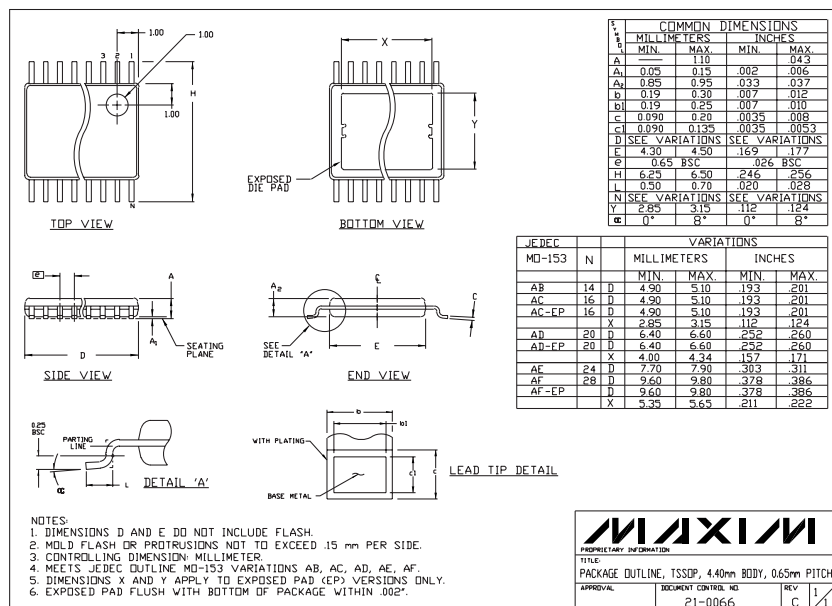

Note: The MAX4294 does not have an exposed pad.

Ultra-Small, 1.8V, μ Power, Rail-to-Rail I/O Op Amps

Package Information (continued)

(The package drawing(s) in this data sheet may not reflect the most current specifications. For the latest package outline information, go to www.maxim-ic.com/packages.)

MAX4291/MAX4292/MAX4294

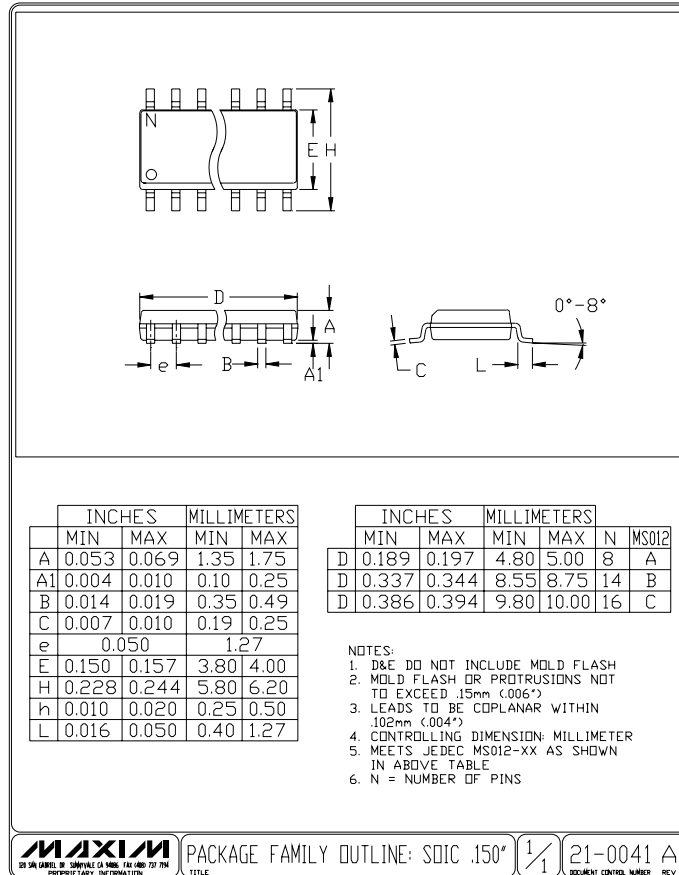

Ultra-Small, 1.8V, μ Power, Rail-to-Rail I/O Op Amps

Package Information (continued)

(The package drawing(s) in this data sheet may not reflect the most current specifications. For the latest package outline information, go to www.maxim-ic.com/packages.)

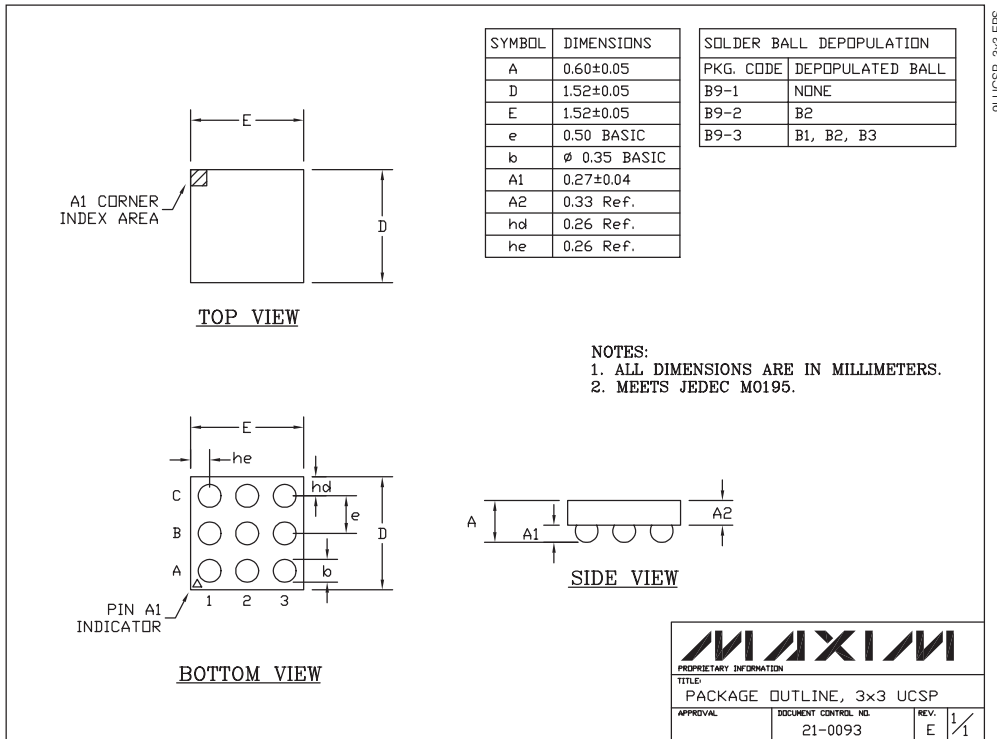

91UCSP-3x3.EPS

Maxim cannot assume responsibility for use of any circuitry other than circuitry entirely embodied in a Maxim product. No circuit patent licenses are implied. Maxim reserves the right to change the circuitry and specifications without notice at any time.

18 _____ **Maxim Integrated Products, 120 San Gabriel Drive, Sunnyvale, CA 94086 408-737-7600**

Mouser Electronics

Authorized Distributor

Click to View Pricing, Inventory, Delivery & Lifecycle Information:

Maxim Integrated:

[MAX4291EUK+T](#) [MAX4291EUK-T](#) [MAX4291EXK+T](#) [MAX4291EXK-T](#) [MAX4292ESA](#) [MAX4292ESA+](#)
[MAX4292ESA+T](#) [MAX4292EUA](#) [MAX4292EUA+](#) [MAX4292EUA+T](#) [MAX4294ESD+](#) [MAX4294ESD+T](#)
[MAX4294EUD+](#) [MAX4294EUD+T](#) [MAX4292ESA-T](#) [MAX4292EUA-T](#) [MAX4292EBL-T](#) [MAX4292EBL+T](#)