

**ABSOLUTE MAXIMUM RATINGS**

Symbol	Parameter	Value	Unit
V <sub>S</sub>	DC Supply Voltage	35	V
P <sub>tot</sub>	Total Power Dissipation (T <sub>amb</sub> = 70°C)	20	W
T <sub>amb</sub>	Ambient Operating Temperature (1)	0 to 70	°C
T <sub>stg</sub> , T <sub>j</sub>	Storage and Junction Temperature	-40 to 150	°C

(1) Operation between -20 to 85 °C guaranteed by correlation with 0 to 70°C.

**PIN CONNECTION (Top view)**

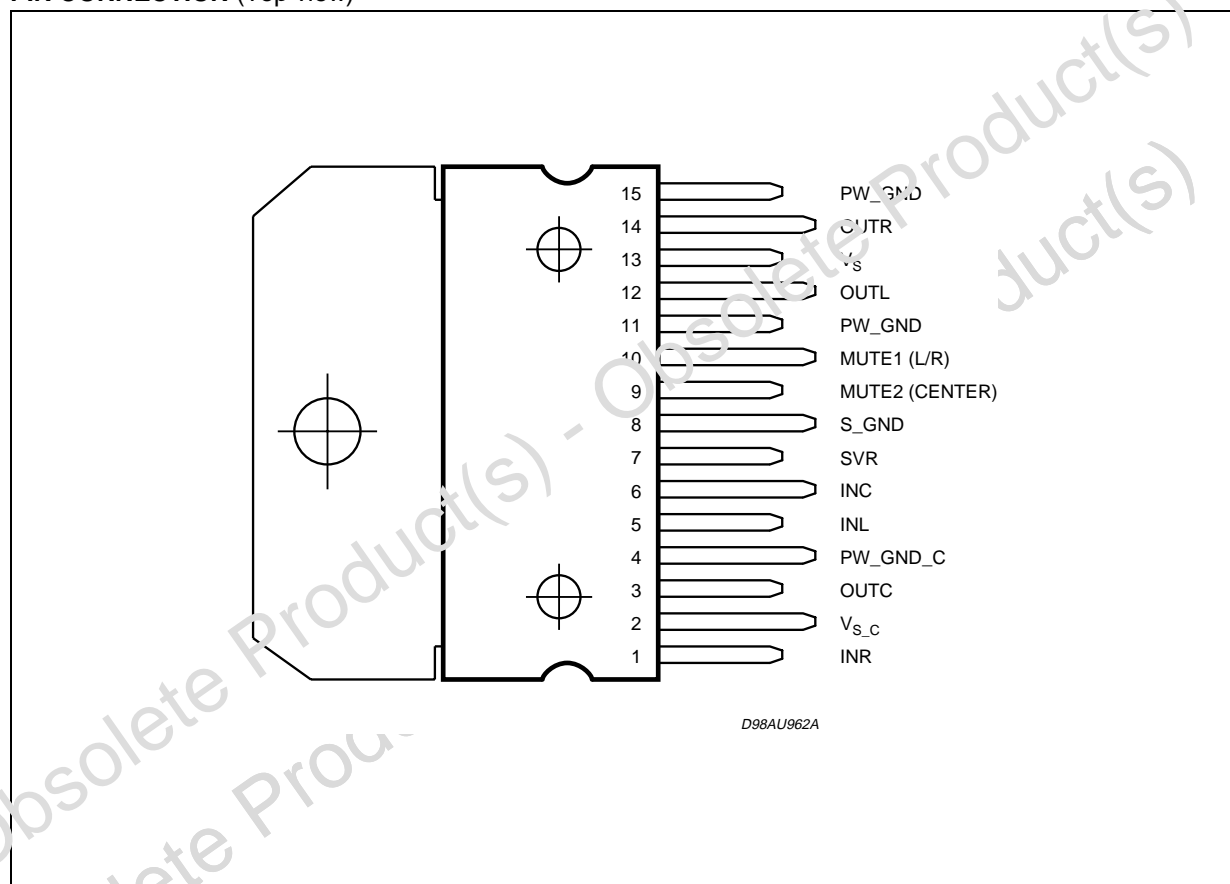

**THERMAL DATA**

Symbol	Parameter	Value	Unit
R <sub>th j-case</sub>	Thermal Resistance Junction-case	Typ.=1.3 max = 1.9	°C/W
R <sub>th j-amb</sub>	Thermal Resistance Junction-ambient	max = 35	°C/W

**ELECTRICAL CHARACTERISTICS** (Refer to the test circuit  $V_S = 26V$ ;  $R_L = 8\Omega$ ,  $f = 1KHz$ ,  $R_g = 50\Omega$ ,  $T_{amb} = 25^\circ C$ )

Symbol	Parameter	Test Condition	Min.	Typ.	Max.	Unit
$V_S$	Supply Voltage Range		11		32	V
$I_q$	Total Quiescent Current			60	100	mA
$V_O$	Quiescent Output Voltage		12	13	14	V
$P_{O\_L/R}$	Output Power Left / Right Channels	THD = 10%	8	10		W
		THD = 1%;	6	7.5		W
		THD = 10%; $R_L = 4\Omega$ ; $V_S = 20V$	7	8		W
		THD = 1%; $R_L = 4\Omega$ ; $V_S = 20V$	5	6		W
		THD = 10%; $R_L = 8\Omega$ ; $V_S = 18V$	3.5	3.8		W
		THD = 1%; $R_L = 8\Omega$ ; $V_S = 18V$	2.2	2.9		W
$P_{O\_C}$	Output Power Center Channel	THD = 10%	8	10		W
		THD = 1%	6	7.5		W
		THD = 10%; $R_L = 4\Omega$	15	13		W
		THD = 1%; $R_L = 4\Omega$	11	14		W
THD	Total Harmonic Distortion	PO = 1W; f = 1KHz;			0.4	%
$I_{peak\ L/R}$	Output Peak Current	(internally limited)		2.4		A
$I_{peak\ C}$	Output Peak Current Central Channel	(internally limited)		2.8		A
GV	Closed Loop Gain		28.5	29.5	30.5	dB
$\Delta GV$	L/R Voltage Gain Matching		-1		1	dB
BW				0.6		MHz
$e_N$	Total Output Noise	f = 20Hz to 22KHz		60	150	$\mu V$
SR	Slew Rate		5	8		V/ $\mu s$
$R_i$	Input Resistance		22.5	30		K $\Omega$
SVR	Supply Voltage Rejection	f = 1kHz CSV <sub>R</sub> = 470 $\mu F$ ; VRIP = 1V <sub>rms</sub>	50	60		dB
$T_M$	Thermal Muting			150		$^\circ C$
$T_c$	Thermal Shut-down			160		$^\circ C$
<b>MUTE &amp; INPUT SELECTION FUNCTIONS</b>						
$V_{MUTE1}$	Mute 1 ON threshold (L/R)		3.5			V
	Mute 1 OFF threshold (L/R)				1.5	V
$V_{MUTE2}$	Mute 2 ON Threshold (center)		3.5			V
	Mute 2 OFF Threshold (center)				1.5	V
$A_{MUTE}$	Mute Attenuation		50	65		dB
$I_{muteBIAS}$	Mute bias current Mute1/Mute2	Mute		1	5	$\mu A$
		Play		0.2	2	$\mu A$

Figure 1. PC Boar and Component Layout

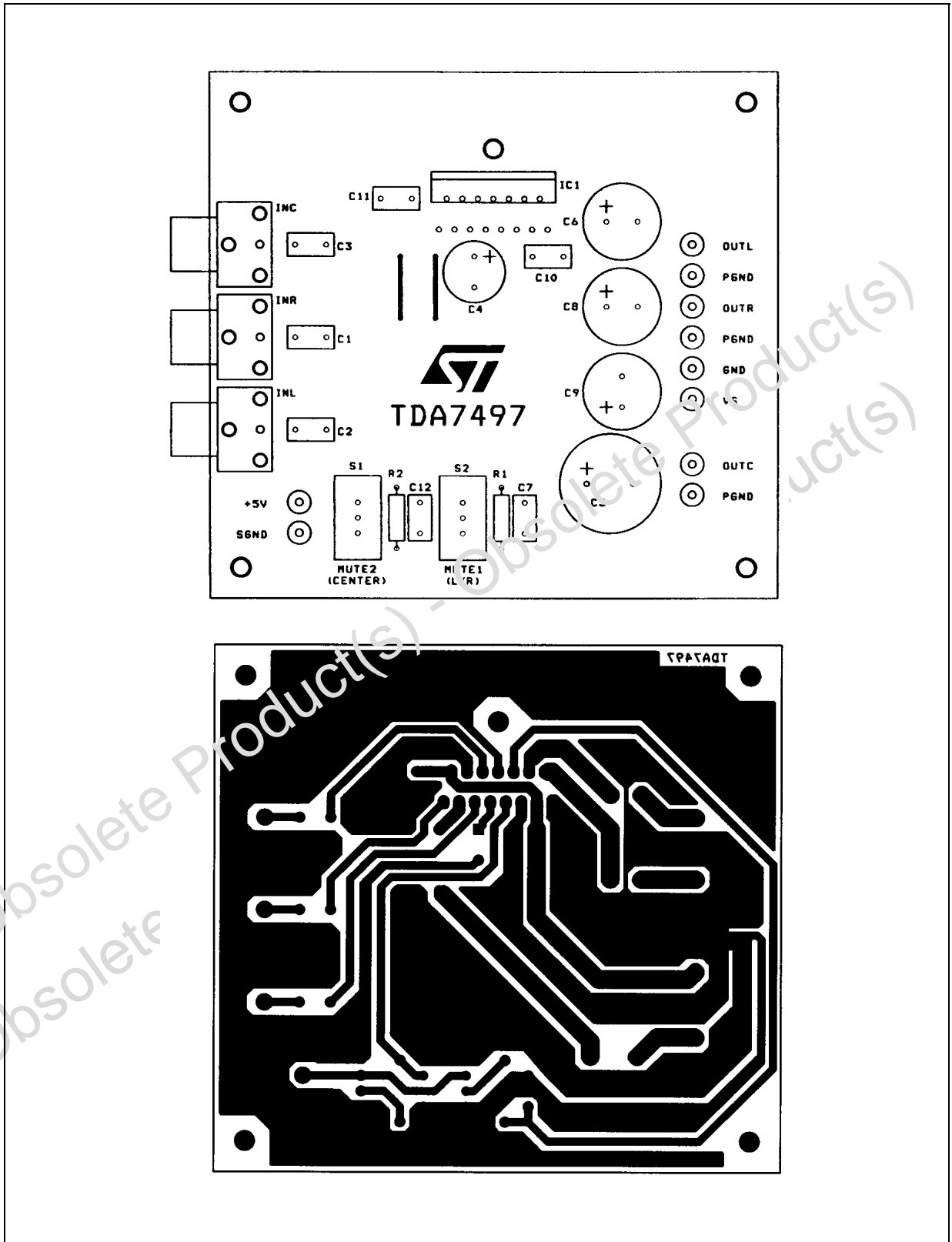

Figure 2. Output Power vs Supply Voltage (L/R)

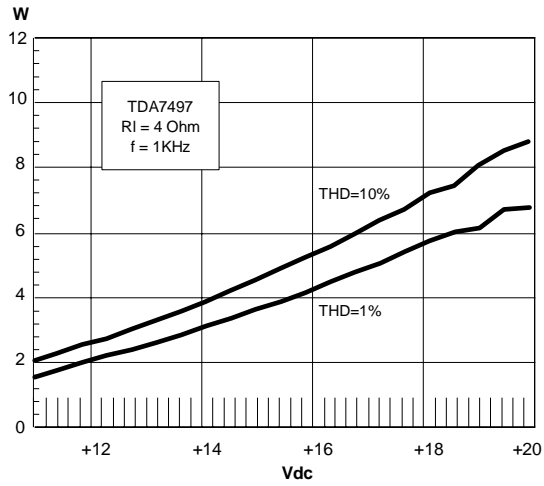

Figure 5. THD+N vs Output Power

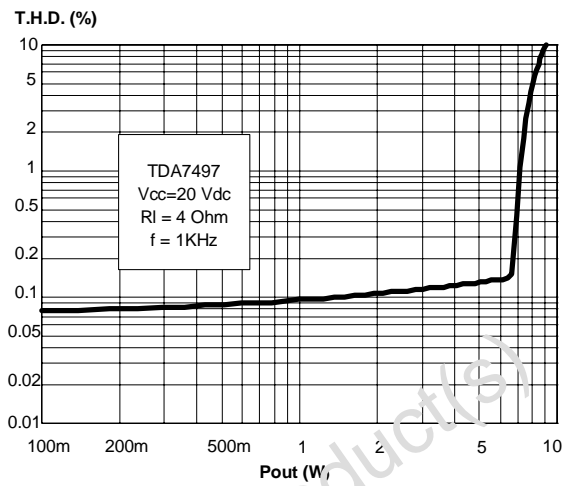

Figure 3. Output Power vs Supply Voltage

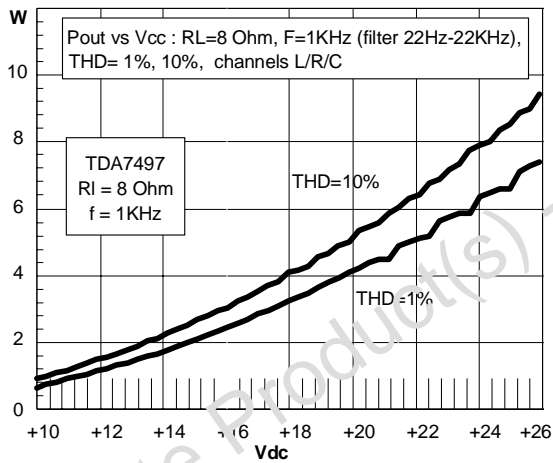

Figure 6. THD+N vs Output Power

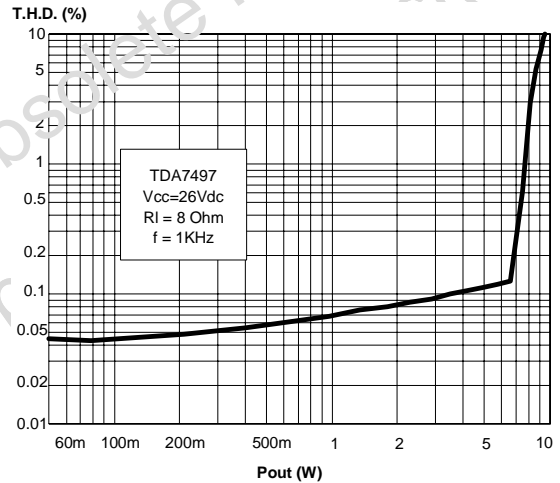

Figure 4. Frequency Response

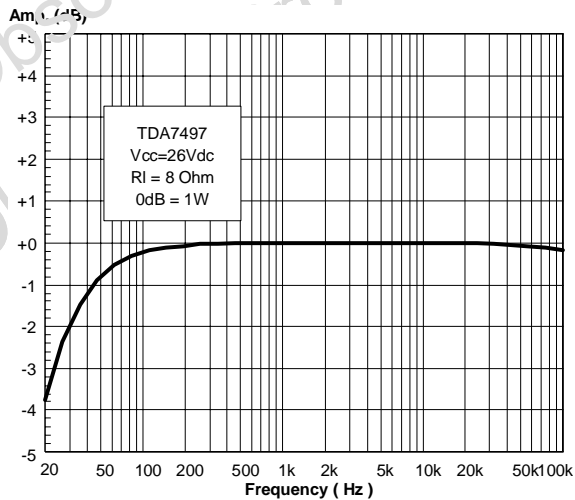
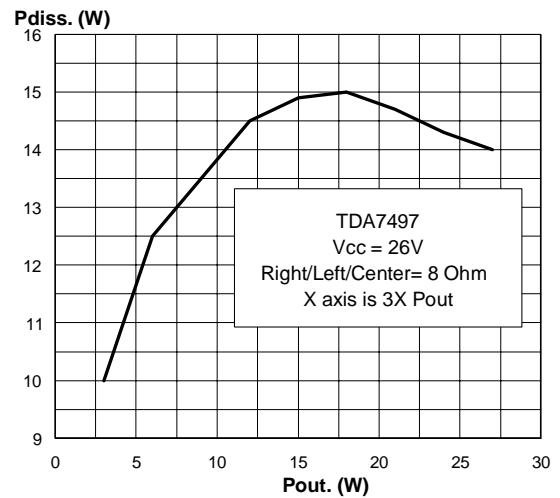
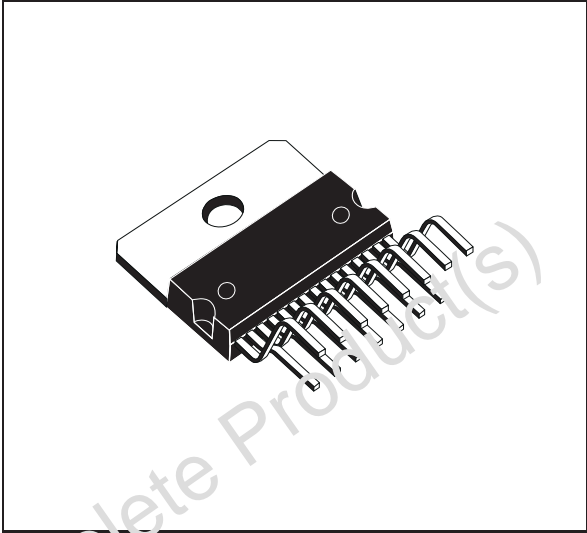

Figure 7. P<sub>diss</sub> vs Output Power



DIM.	mm			inch		
	MIN.	TYP.	MAX.	MIN.	TYP.	MAX.
A			5			0.197
B			2.65			0.104
C			1.6			0.063
D		1			0.039	
E	0.49		0.55	0.019		0.022
F	0.66		0.75	0.026		0.030
G	1.02	1.27	1.52	0.040	0.050	0.060
G1	17.53	17.78	18.03	0.690	0.700	0.710
H1	19.6			0.772		
H2			20.2			0.795
L	21.9	22.2	22.5	0.862	0.874	0.886
L1	21.7	22.1	22.5	0.854	0.870	0.886
L2	17.65		18.1	0.695		0.713
L3	17.25	17.5	17.75	0.679	0.689	0.699
L4	10.3	10.7	10.9	0.406	0.421	0.429
L7	2.65		2.9	0.104		0.114
M	4.25	4.55	4.85	0.167	0.179	0.191
M1	4.63	5.08	5.53	0.182	0.200	0.218
S	1.9		2.6	0.075		0.102
S1	1.9		2.6	0.075		0.102
Dia1	3.65		3.85	0.144		0.152

**OUTLINE AND MECHANICAL DATA**



**Multiwatt15 V**

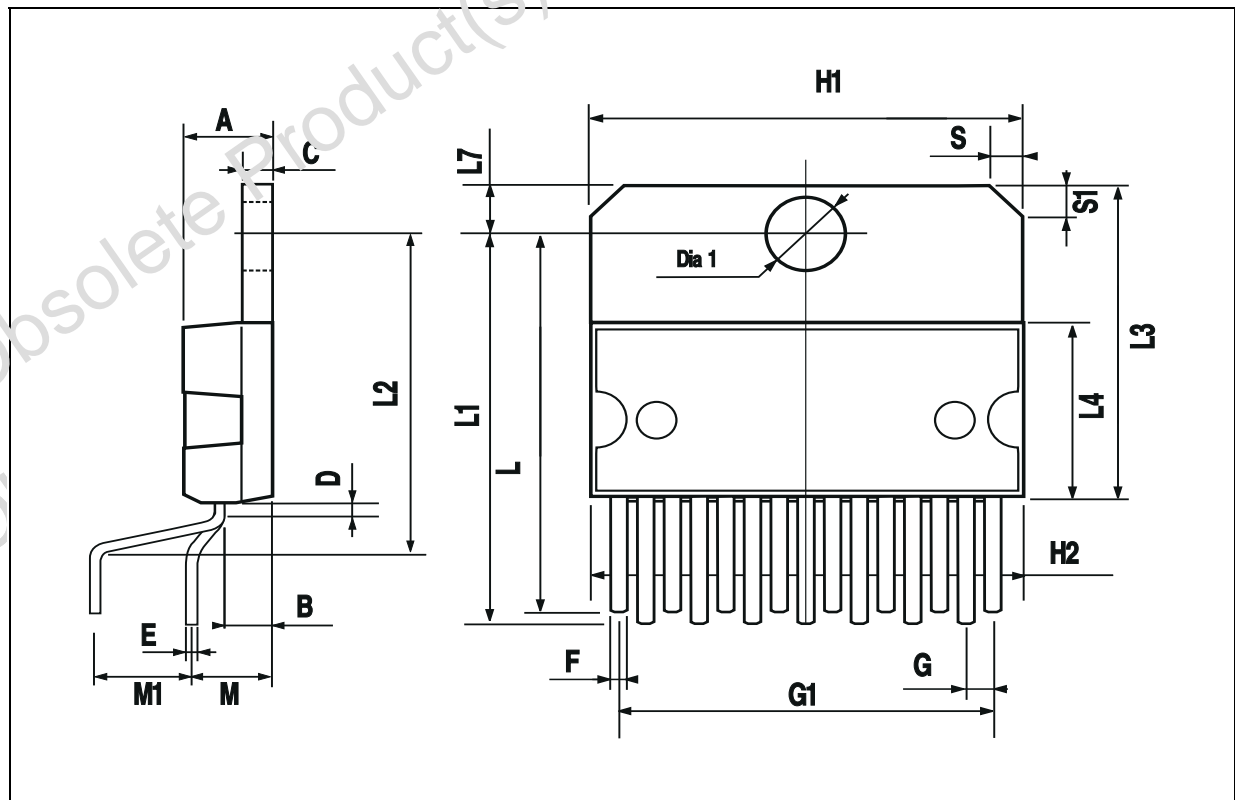

Obsolete Product(s) - Obsolete Product(s)  
Obsolete Product(s) - Obsolete Product(s)

Information furnished is believed to be accurate and reliable. However, STMicroelectronics assumes no responsibility for the consequences of use of such information nor for any infringement of patents or other rights of third parties which may result from its use. No license is granted by implication or otherwise under any patent or patent rights of STMicroelectronics. Specifications mentioned in this publication are subject to change without notice. This publication supersedes and replaces all information previously supplied. STMicroelectronics products are not authorized for use as critical components in life support devices or systems without express written approval of STMicroelectronics.

The ST logo is a registered trademark of STMicroelectronics  
© 2003 STMicroelectronics - All Rights Reserved

Australia - Brazil - Canada - China - Finland - France - Germany - Hong Kong - India - Israel - Italy - Japan - Malaysia - Malta - Morocco - Singapore - Spain - Sweden - Switzerland - United Kingdom - United States.  
<http://www.st.com>