

Single-Input 1-Cell Li+ Charger with OVP Protection and Programmable Charge Timer

ABSOLUTE MAXIMUM RATINGS

| | |
|---|----------------------|
| $\overline{P}OK$ to GND..... | -0.3V to (DC + 0.3V) |
| DC to GND | -0.3V to +16V |
| BAT, CT, \overline{CHG} , \overline{EN} , \overline{FLT} , SETI, THM to GND | -0.3V to +5.5V |
| Continuous Power Dissipation ($T_A = +70^\circ\text{C}$) 14-Pin TDFN 3mm x 3mm Multilayer PCB (derate 24.4mW/ $^\circ\text{C}$ above $+70^\circ\text{C}$)..... | 1951.2mW |

| | |
|---|---|
| Operating Temperature Range | -40 $^\circ\text{C}$ to +85 $^\circ\text{C}$ |
| Junction Temperature Range | -40 $^\circ\text{C}$ to +150 $^\circ\text{C}$ |
| Storage Temperature Range | -65 $^\circ\text{C}$ to +150 $^\circ\text{C}$ |
| Lead Temperature (soldering, 10s) | +300 $^\circ\text{C}$ |

Stresses beyond those listed under "Absolute Maximum Ratings" may cause permanent damage to the device. These are stress ratings only, and functional operation of the device at these or any other conditions beyond those indicated in the operational sections of the specifications is not implied. Exposure to absolute maximum rating conditions for extended periods may affect device reliability.

ELECTRICAL CHARACTERISTICS

($V_{DC} = 5\text{V}$, $V_{BAT} = 3.6\text{V}$, $V_{\overline{EN}} = 0\text{V}$, $R_{SETI} = 2\text{k}\Omega$, $C_{CT} = 0.068\mu\text{F}$, $T_A = -40^\circ\text{C}$ to $+85^\circ\text{C}$, unless otherwise noted. Typical values are at $T_A = +25^\circ\text{C}$.) (Note 1)

| PARAMETER | CONDITIONS | | MIN | TYP | MAX | UNITS |
|-----------------------------------|--|--|-------|-------|-------|------------------|
| DC | | | | | | |
| Input Voltage Range | | | 0 | | 14 | V |
| Input Operating Range | (Note 2) | | 4.1 | | 6.0 | V |
| Input Undervoltage Threshold | When $\overline{P}OK$ goes low, DC rising, 500mV hysteresis | | 3.89 | 4.0 | 4.10 | V |
| Input Overvoltage Threshold | When $\overline{P}OK$ goes high, DC rising, 200mV hysteresis | | 6.2 | 6.5 | 6.8 | V |
| Input Supply Current | $I_{BAT} = 0\text{mA}$, $R_{THM} = 10\text{k}\Omega$ | | | 980 | 2000 | μA |
| Shutdown Input Current | $V_{\overline{EN}} = 5\text{V}$ | | | 275 | 435 | μA |
| Input to BAT On-Resistance | $V_{DC} = 3.7\text{V}$, $V_{BAT} = 3.6\text{V}$ | | | 0.25 | 0.5 | Ω |
| Input to BAT Dropout Voltage | DC falling, 200mV hysteresis | | 5 | 75 | 150 | mV |
| BAT | | | | | | |
| BAT Regulation Voltage | $I_{BAT} = 0\text{mA}$ | $T_A = +25^\circ\text{C}$ | 4.179 | 4.2 | 4.221 | V |
| | | $T_A = -40^\circ\text{C}$ to $+85^\circ\text{C}$ | 4.166 | 4.2 | 4.234 | |
| BAT Restart Fast-Charge Threshold | From BAT regulation voltage | | -180 | -150 | -120 | mV |
| DC Charging Current | $R_{SETI} = 1.5\text{k}\Omega$ | | 950 | 1000 | 1050 | mA |
| | $R_{SETI} = 2\text{k}\Omega$ | | 675 | 750 | 825 | |
| | $R_{SETI} = 5\text{k}\Omega$ | | 275 | 300 | 325 | |
| | $R_{SETI} = 2\text{k}\Omega$, $V_{BAT} = 2.0\text{V}$ | | 67.5 | 75 | 82.5 | |
| Soft-Start Time | Ramp time to fast-charge current | | | 1.2 | | ms |
| BAT Prequal Threshold | When charging current changes, BAT rising, 170mV hysteresis | | 2.30 | 2.50 | 2.54 | V |
| BAT Leakage Current | $V_{DC} = 0\text{V}$, $V_{BAT} = 4.2\text{V}$ | | | 0.001 | 5 | μA |
| CONTROL INPUTS AND OUTPUTS | | | | | | |
| SETI | | | | | | |
| R_{SETI} Resistance Range | Guaranteed by charging current | | 1.5 | | 5.0 | $\text{k}\Omega$ |

Single-Input 1-Cell Li+ Charger with OVP Protection and Programmable Charge Timer

ELECTRICAL CHARACTERISTICS (continued)

($V_{DC} = 5V$, $V_{BAT} = 3.6V$, $V_{\overline{EN}} = 0V$, $R_{SET1} = 2k\Omega$, $C_{CT} = 0.068\mu F$, $T_A = -40^\circ C$ to $+85^\circ C$, unless otherwise noted. Typical values are at $T_A = +25^\circ C$.) (Note 1)

| PARAMETER | CONDITIONS | MIN | TYP | MAX | UNITS | |
|---|--|-------------------------|-------|------|---------------|----|
| \overline{EN} | | | | | | |
| Logic Input Thresholds | Rising | | | 1.6 | V | |
| | Falling | 0.4 | | | | |
| Logic Input Resistance to GND | | 250 | 485 | 1000 | k Ω | |
| \overline{POK} | | | | | | |
| Logic Output Voltage, Low | $I_{\overline{POK}} = 100\mu A$ | | 29 | 100 | mV | |
| Logic Output Leakage Current, High | $V_{\overline{POK}} = V_{DC} = 16V$ | $T_A = +25^\circ C$ | 0.001 | 1 | μA | |
| | | $T_A = +85^\circ C$ | 0.01 | | | |
| \overline{CHG}, \overline{FLT} | | | | | | |
| Logic Output Voltage, Low | $I_{\overline{CHG}} = I_{\overline{FLT}} = 1mA$ | | 12 | 100 | mV | |
| Logic Output Leakage Current, High | $V_{\overline{CHG}} = V_{\overline{FLT}} = 5.5V$, $V_{DC} = 0V$ | $T_A = +25^\circ C$ | 0.001 | 1 | μA | |
| | | $T_A = +85^\circ C$ | 0.01 | | | |
| \overline{CHG} | | | | | | |
| \overline{CHG} /Top-Off Current Threshold | I_{BAT} falling, battery is charged | $R_{SET1} = 1.5k\Omega$ | | 60 | mA | |
| | | $R_{SET1} = 2k\Omega$ | 30 | 45 | | 60 |
| | | $R_{SET1} = 5k\Omega$ | | 18 | | |
| THM | | | | | | |
| THM Pullup Resistance | Match to thermistor resistance at $T_A = +25^\circ C$ | -1% | 10 | +1% | k Ω | |
| THM Resistance, Hot | R_{THM} falling, 420 Ω hysteresis | 3.72 | 3.94 | 4.13 | k Ω | |
| THM Resistance, Cold | R_{THM} rising, 2.7k Ω hysteresis | 26.7 | 28.3 | 29.7 | k Ω | |
| THM Resistance, Disabled | R_{THM} falling, 230 Ω hysteresis | 240 | 309 | 370 | Ω | |
| TIMERS, CT | | | | | | |
| Timer Accuracy | $C_{CT} = 0.068\mu F$ | -20 | | +20 | % | |
| Prequal Time Limit | From \overline{POK} low and \overline{EN} low to end of prequal charge, $BAT < 2.4V$, $C_{CT} = 0.068\mu F$ | | 34.8 | | min | |
| Charge Time Limit | From \overline{POK} low and \overline{EN} low to end of charge, $C_{CT} = 0.068\mu F$ | | 334 | | min | |
| Top-Off Time Limit | From \overline{CHG} high to done, $C_{CT} = 0.068\mu F$ | | 69.6 | | min | |
| THERMAL LOOP | | | | | | |
| Thermal-Limit Temperature | Junction temperature when the charge current is reduced, T_J rising | | +100 | | $^\circ C$ | |
| Thermal-Limit Gain | Reduction of I_{BAT} for increase of T_J , I_{BAT}/T_J (over $+100^\circ C$) | | 5 | | %/ $^\circ C$ | |

Note 1: Limits are 100% production tested at $T_A = +25^\circ C$. Limits over the operating temperature range are guaranteed by design and characterization.

Note 2: Guaranteed by undervoltage- and overvoltage-threshold testing. For complete charging, the input voltage must be greater than 4.35V.

Single-Input 1-Cell Li+ Charger with OVP Protection and Programmable Charge Timer

Typical Operating Characteristics

($V_{DC} = 5V$, $R_{SET1} = 2k\Omega$, $V_{BAT} = 3.6V$, MAX8601 Evaluation Kit with thermal resistance of $50^{\circ}C/W$. $T_A = +25^{\circ}C$, unless otherwise noted.)

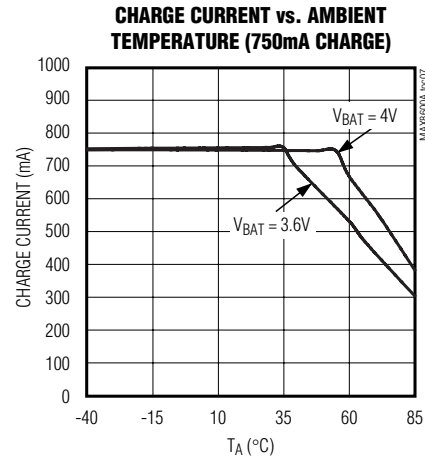
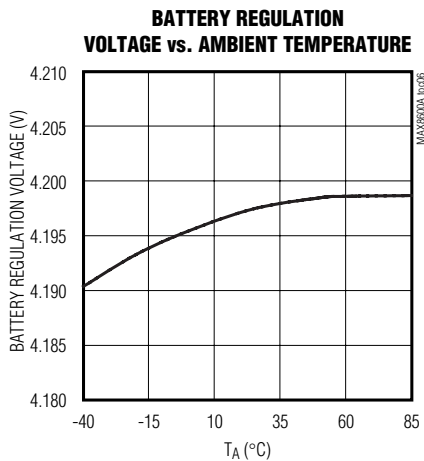
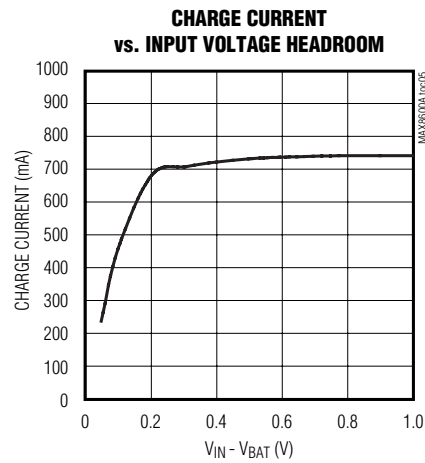
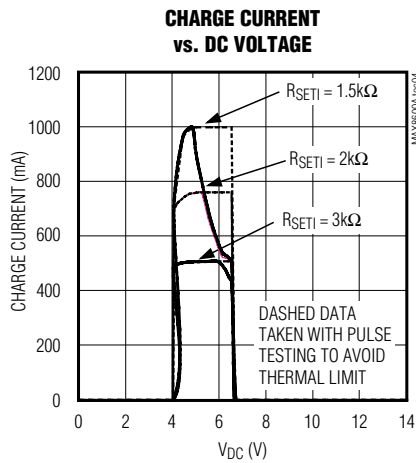
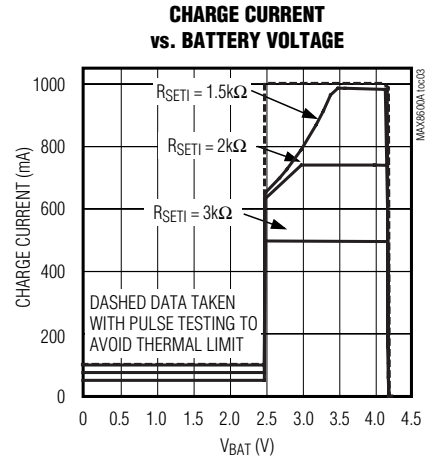
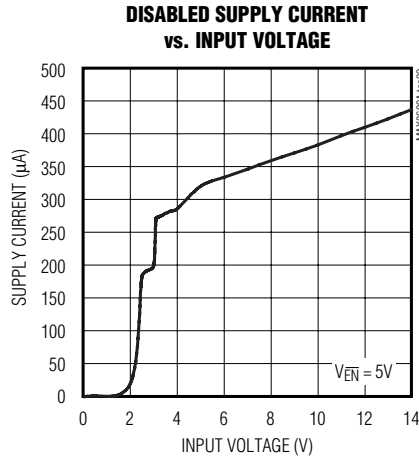
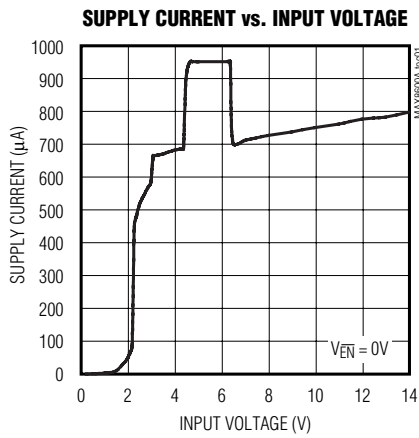

Single-Input 1-Cell Li+ Charger with OVP Protection and Programmable Charge Timer

Typical Operating Characteristics (continued)

(V_{DC} = 5V, R_{SETI} = 2kΩ, V_{BAT} = 3.6V, MAX8601 Evaluation Kit with thermal resistance of 50°C/W. T_A = +25°C, unless otherwise noted.)

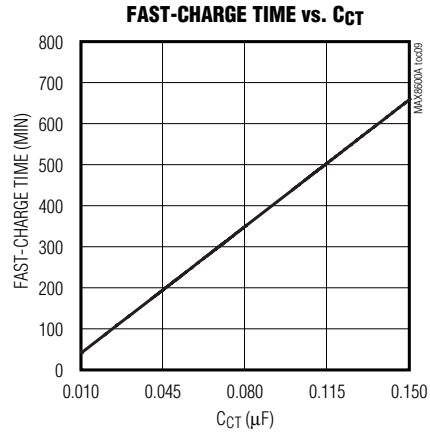
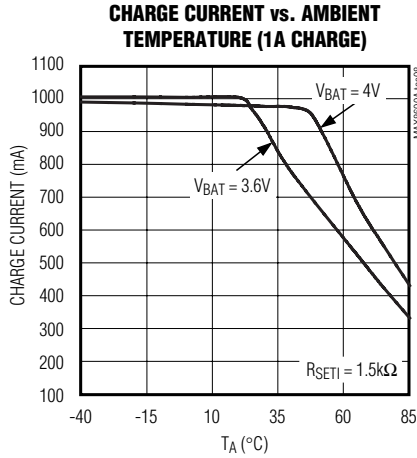

Pin Description

| PIN | NAME | FUNCTION |
|------|------------------|--|
| 1, 7 | BAT | Battery Connection. The IC delivers charging current and monitors battery voltage using BAT. Bypass BAT to GND with a 2.2μF or larger ceramic capacitor. Connect both BAT inputs together externally. BAT is high impedance when the IC is disabled. Ensure that all BAT pins are connected together. |
| 2 | SETI | DC Charge-Current Programming Pin. Connect a resistor from SETI to GND to set the maximum charging current (I _{BAT} = 1500V/R _{SETI}), the prequal current, and the CHG done threshold. Monitor charging current by measuring this pin voltage. SETI is high-impedance when \overline{EN} is high, or DC is at GND. |
| 3 | THM | Thermistor Input. Connect a 10kΩ NTC thermistor, in close proximity to the battery, from THM to ground to monitor the battery temperature. The IC suspends charging when R _{THM} is outside the hot and cold limits. Disable thermistor functionality by connecting THM to GND. THM is high impedance when \overline{EN} is high or DC is at GND. |
| 4 | GND | Ground |
| 5 | CT | Timing Capacitor Input. Connect a capacitor from CT to GND to set the precharge timeout, top-off time, and fast-charge timeout. Connect CT to GND to disable the timers. CT is high impedance when \overline{EN} is high or DC is at GND. |
| 6 | N.C. | No Connection. Make no external circuit connection. |
| 8 | \overline{EN} | Active-Low Enable Input. Drive low or connect \overline{EN} to GND to enable the charger. Drive \overline{EN} high to disable the charger. \overline{EN} has an internal 470kΩ pulldown resistance to GND. |
| 10 | \overline{POK} | Power-OK Monitor. \overline{POK} is an open-drain output that pulls low when a valid charging source is detected. \overline{POK} is high impedance when DC voltage is outside valid range. \overline{POK} remains active monitoring DC with the charger enabled or disabled. |

Single-Input 1-Cell Li+ Charger with OVP Protection and Programmable Charge Timer

Pin Description (continued)

| PIN | NAME | FUNCTION |
|-----------|-------------------------|--|
| 11 | $\overline{\text{CHG}}$ | Charging-Status Output. $\overline{\text{CHG}}$ pulls low when the battery is above 2.5V and being charged with a current greater than 6% of the current programmed with R_{SET1} . $\overline{\text{CHG}}$ is high impedance when the charger is in prequal, top-off, or disabled. |
| 9, 12, 13 | DC | DC Input Source. Connect directly to a 4.5V to 6.0V charging source. Bypass DC to GND with 1 μ F or greater. DC is overvoltage protected to 14V. Ensure that all DC pins are connected together. |
| 14 | $\overline{\text{FLT}}$ | Fault Status Output. $\overline{\text{FLT}}$ pin pulls low when the fast-charge or prequal timers expire and the battery voltage is not above the required threshold. Clear the fault by raising $\overline{\text{EN}}$ or dropping DC to GND (remove input power). |
| — | EP | Exposed Pad. Connect EP to the GND plane for optimum thermal dissipation. |

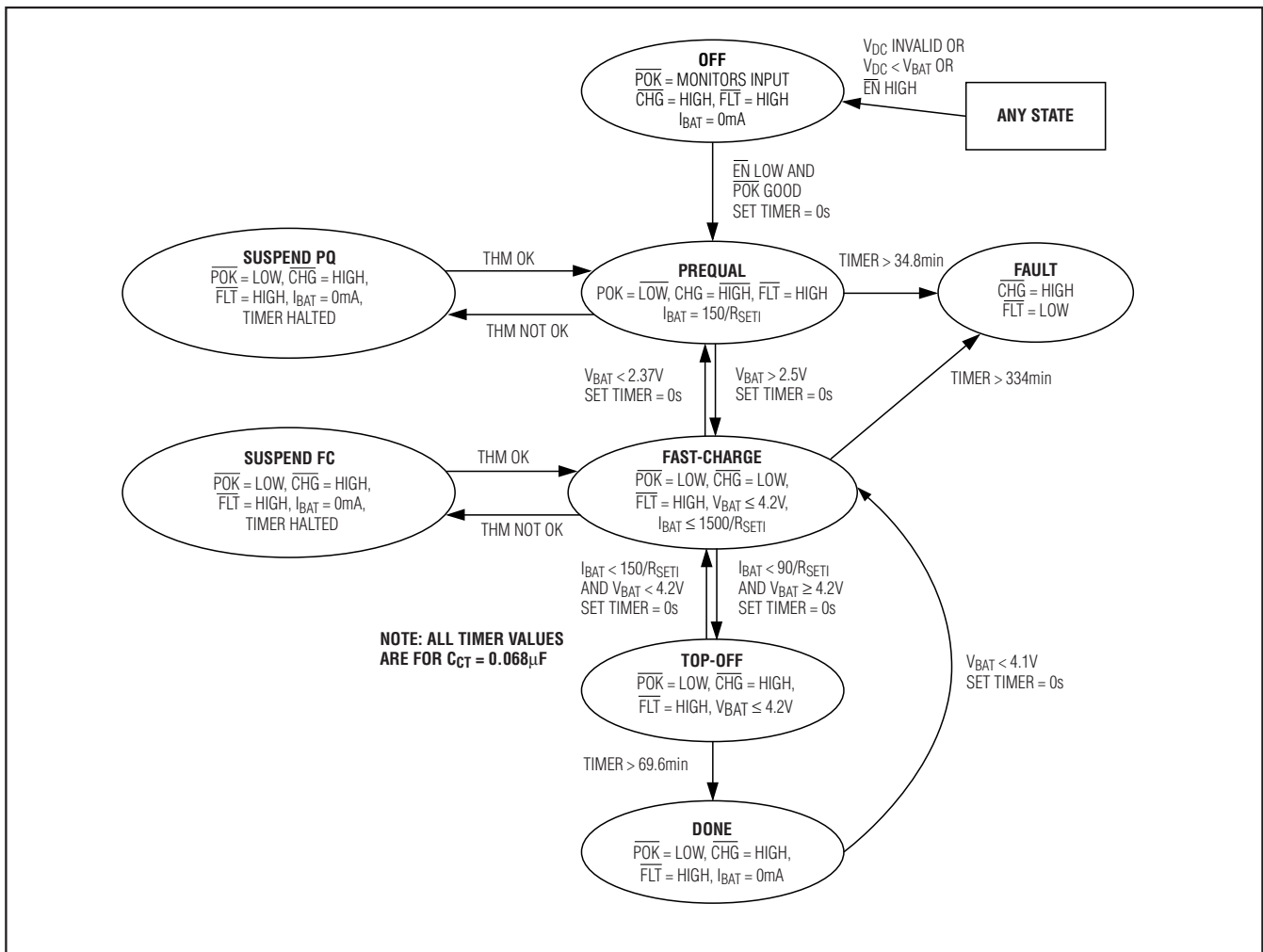

Figure 1. Charger State Diagram

Single-Input 1-Cell Li+ Charger with OVP Protection and Programmable Charge Timer

Detailed Description

The MAX8600A is a single-cell Li+ battery charger. Charging is optimized for Li+ cells using a control algorithm that includes low-battery precharging, charging with simultaneous voltage and current compliance, and top-off charging. The battery is continuously monitored for over/under temperature, and charging is suspended if the temperature is out of range. Charging is also terminated when the input source voltage is greater than 6.5V, or after excess charging time (fault). Charger timeout protection is programmable. Charger status is indicated by three open drain outputs: POK, CHG, and FLT. An input overvoltage protection circuit prevents charging from improper input sources.

The MAX8600A reduces charging time by continuously adjusting the charge rate to accommodate the thermal characteristics of a given application. There is no need to reduce the maximum charge current based on worst-case supply voltage, temperature, and thermal resistance.

DC Charging

The MAX8600A is designed to charge a single-cell Li+ battery from a DC source voltage between 4.1V and 6.0V. The precharge current, charge current, and top-off threshold are programmable with RSETI.

EN Charger-Enable Input

EN is a logic input (active low) that enables the charger. Drive EN high to disable the charger-control circuitry. Drive EN low or connect to GND for normal operation.

Soft-Start

To prevent input transients, the rate of charging current is limited. When the charger is turned on or when the input source is changed, charge current is ramped from 0 to the set current value in typically 1.2ms. This is done to ensure that the DC source is not subjected to a severe load current step.

Charge-current ramp-up is also limited when transitioning from prequal to fast-charge. There is no di/dt limiting, however, if ISET is changed suddenly using a switch at RSETI.

Thermal-Limit Control

The MAX8600A features a thermal limit that reduces the charge current when the die temperature exceeds +100°C. As the temperature increases above +100°C, the IC lowers the fast-charge current compliance by 5%/°C.

CHG Charge-Indicator Output

CHG is an open-drain output that indicates charger status. CHG goes low during charge cycles where VBAT is greater than 2.5V and IBAT is greater than 6% of the

maximum charge current set by RSETI. When the MAX8600A is used in conjunction with a microprocessor (μP), connect a pullup resistor between CHG and the logic I/O voltage to indicate charge status to the μP. Alternatively, CHG can sink up to 20mA for an LED charge indicator.

Fault Indicator (FLT)

The MAX8600A contains an open-drain FLT output to signal the user when a fault occurs. FLT goes low if the charger is in prequal and the prequal timer expires, or if the charger is in fast-charge and the fast-charge time expires. FLT does not go low if the THM thermistor temperature is out of range. Toggle EN or the input power to reset the FLT indicator.

Power-OK Indicator (POK)

The MAX8600A contains an open-drain POK output that goes low when a valid input source is detected at DC. A valid input source is one whose voltage is between 4.1V and 6.0V and exceeds the battery voltage by 350mV. After a valid input has been established, charging is sustained with inputs as low as 3.5V as long as the input voltage remains above the battery voltage by at least 75mV (typ). Figure 2 shows POK being used to drive an external p-channel MOSFET to create a node called SAFE DC. SAFE DC is an overvoltage-protected version of DC.

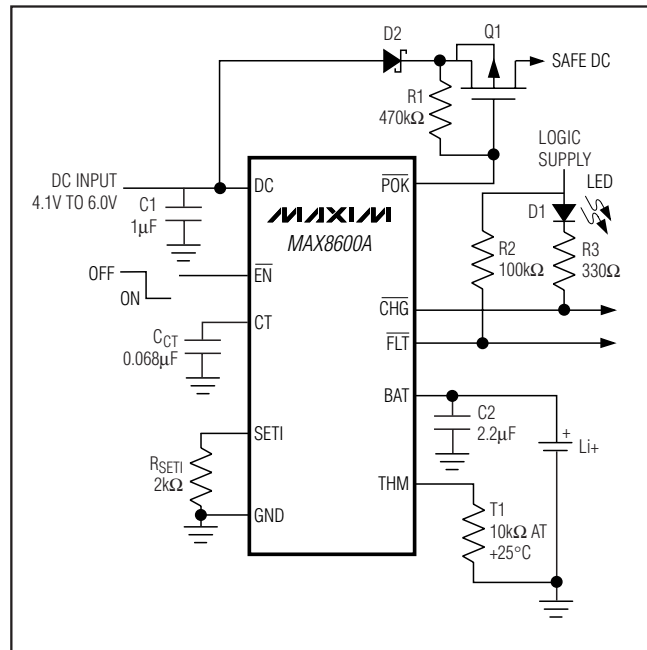

Figure 2. Typical operating circuit. An RSETI of 2kΩ sets a maximum charge current of 750mA.

Single-Input 1-Cell Li+ Charger with OVP Protection and Programmable Charge Timer

Figure 2 External Components List

| COMPONENT | FUNCTION | DESCRIPTION |
|-----------|------------------------------------|---|
| C1 | Filter capacitor | 1μF ceramic capacitor |
| C2 | Filter capacitor | 2.2μF ceramic capacitor |
| CCT | Timing capacitor | 0.068μF low TC ceramic capacitor |
| RSETI | DC charge-current program resistor | 2kΩ 1% (for 750mA charge) |
| R1 | Pullup resistor | 470kΩ |
| R2 | Pullup resistor | 100kΩ |
| R3 | LED current program resistor | 330Ω |
| T1 | Negative TC thermistor | Phillips NTC thermistor, P/N 2322-640-63103, 10kΩ 5% at +25°C |
| D1 | Charge indicator LED | LED |

Table 1. Fault Temperatures for Different Thermistors

| THERMISTOR BETA | 3000 | 3250 | 3500 | 3750 |
|-------------------------------|------------|------------|------------|------------|
| Resistance at +25°C | 10,000Ω | 10,000Ω | 10,000Ω | 10,000Ω |
| Resistance at +50°C | 4587.78Ω | 4299.35Ω | 4029.06Ω | 3775.75Ω |
| Resistance at 0°C | 25,140.55Ω | 27,148.09Ω | 29,315.94Ω | 31,656.90Ω |
| Nominal Hot Trip Temperature | +55.14°C | +52.60°C | +50.46°C | +48.63°C |
| Nominal Cold Trip Temperature | -3.24°C | -1.26°C | +0.46°C | +1.97°C |

Applications Information

Figure 2 shows the typical operating circuit for the MAX8600A. The following section describes component changes for different charging current and timer durations.

Charge-Current Selection

The maximum charging current is programmed by an external resistor (RSETI) connected from SETI to GND. Calculate the RSETI value as follows:

$$R_{SETI} = 1500/I_{CHARGE(MAX)}$$

where I_{CHARGE(MAX)} is in amps and R_{SETI} is in ohms. SETI can also be used to monitor the actual charge-current level. The output voltage at SETI is proportional to the charging current as follows:

$$V_{SETI} = (I_{CHARGE} \times R_{SETI})/1000$$

Note that the prequal charge current (when V_{BAT} < 2.5V) operation is 10% of the fast-charge current set by RSETI.

Also, the top-off charge-current threshold is set to 6% of the fast-charge current set by RSETI.

$$I_{PREQUAL} = 150/R_{SETI}$$

$$I_{TOP-OFF} = 90/R_{SETI}$$

Timer Capacitor Selection

The MAX8600A contains timers for prequal, fast-charge, and top-off operation. These time periods are determined by the capacitance from CT to GND. To set the charge times, calculate C_{CT} as follows:

$$T_{FASTCHARGE} = 334\text{min} \times (C_{CT}/0.068\mu\text{F})$$

$$T_{PREQUAL} = 34.8\text{min} \times (C_{CT}/0.068\mu\text{F})$$

$$T_{TOPOFF} = 69.6\text{min} \times (C_{CT}/0.068\mu\text{F})$$

Note that when THM halts charging, the timers stop and hold their value.

Single-Input 1-Cell Li+ Charger with OVP Protection and Programmable Charge Timer

Battery Temperature Control

The MAX8600A monitors battery temperature through a negative TC thermistor. Select a thermistor resistance that is 10kΩ at +25°C and has a beta of 3500. The IC suspends charging when it is greater than 28.3kΩ or less than 3.94kΩ, which translates to a temperature limit of 0°C to +50°C. Table 1 shows the nominal temperature limits that result from a wide range of available thermistor temperature curves. The curves are defined by the following equation:

$$R_T = R_{25^\circ\text{C}} \times e^{\left\{ \beta \left[\left(\frac{1}{T+273} \right) - \left(\frac{1}{298} \right) \right] \right\}}$$

where β is the BETA term in Table 1.

Connect THM to GND to disable the temperature-control function. When R_{THM} disables charging, all timers pause and hold their value.

Capacitor Selection

Connect a 2.2μF ceramic capacitor from BAT to GND for proper stability. Connect a 1μF ceramic capacitor from DC to GND. Use a larger input bypass capacitor for high charging currents to reduce supply noise. All capacitors should be X5R dielectric or better. Be aware that some capacitors have large voltage coefficients that reduce actual capacitance at higher operating voltages and should be avoided.

Thermal Considerations

The MAX8600A is in a thermally enhanced TDFN package with an exposed paddle. Connect the exposed paddle of the package to a large copper ground plane to provide a thermal contact between the device and the circuit board. The exposed paddle transfers heat away from the device, allowing the IC to charge the battery with maximum current, while minimizing the increase in die temperature. Note that the MAX8600A's thermal-limit control allows the charger to be tolerant of thermally

restricted PCB layouts that are sometimes unavoidable in compact portable designs. With such non-optimal layouts, the charger still operates, but can reduce charge current to manage temperature rise.

DC Input Sources

The MAX8600A operating input voltage range is 4.1V to 6.0V. The device survives input voltages up to 16V without damage to the IC. If the input voltage is greater than 6.5V (typ), the IC stops charging. An appropriate power supply must provide at least 4.2V plus the voltage drop across the internal pass transistor when sourcing the desired maximum charging current.

$$V_{IN(MIN)} > 4.2V + I_{CHARGE(MAX)} \times R_{ON}$$

where R_{ON} is the input-to-BAT resistance (typically 0.25Ω). Failure to meet this requirement results in an incomplete charge or increased charge time.

Layout and Bypassing

Connect the input capacitors as close as possible to the device. Provide a large copper GND plane to allow the exposed paddle to sink heat away from the device. Connect the battery to BAT as close as possible to the IC to provide accurate battery voltage sensing. Make all high-current traces short and wide to minimize voltage drops. For an example layout, refer to the MAX8600A Evaluation Kit.

Chip Information

TRANSISTOR COUNT: 6838

PROCESS: BiCMOS

Single-Input 1-Cell Li+ Charger with OVP Protection and Programmable Charge Timer

Package Information

For the latest package outline information and land patterns, go to www.maxim-ic.com/packages.

| PACKAGE TYPE | PACKAGE CODE | DOCUMENT NO. |
|--------------|--------------|-------------------------|
| 14 TDFN-EP | T1433-2 | 21-0137 |

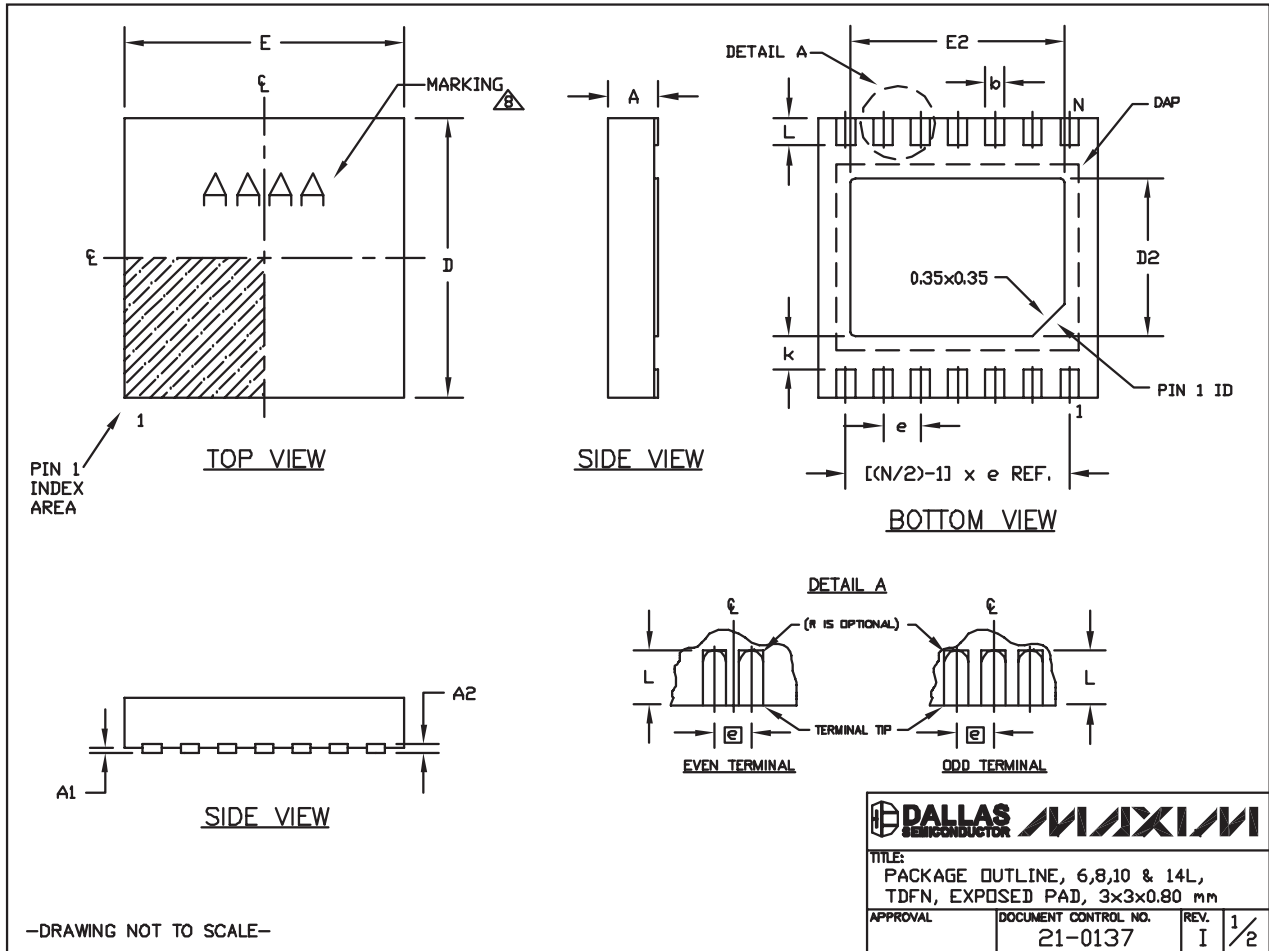

Single-Input 1-Cell Li+ Charger with OVP Protection and Programmable Charge Timer

Package Information (continued)

For the latest package outline information and land patterns, go to www.maxim-ic.com/packages.

MAX8600A

| COMMON DIMENSIONS | | |
|-------------------|-----------|------|
| SYMBOL | MIN. | MAX. |
| A | 0.70 | 0.80 |
| D | 2.90 | 3.10 |
| E | 2.90 | 3.10 |
| A1 | 0.00 | 0.05 |
| L | 0.20 | 0.40 |
| k | 0.25 MIN. | |
| A2 | 0.20 REF. | |

| PACKAGE VARIATIONS | | | | | | | | |
|--------------------|----|-----------|-----------|----------|----------------|-----------|---------------|--|
| PKG. CODE | N | D2 | E2 | e | JEDEC SPEC | b | [(N/2)-1] x e | |
| T633-2 | 6 | 1.50±0.10 | 2.30±0.10 | 0.95 BSC | MO229 / WEEA | 0.40±0.05 | 1.90 REF | |
| T833-2 | 8 | 1.50±0.10 | 2.30±0.10 | 0.65 BSC | MO229 / WEEC | 0.30±0.05 | 1.95 REF | |
| T833-3 | 8 | 1.50±0.10 | 2.30±0.10 | 0.65 BSC | MO229 / WEEC | 0.30±0.05 | 1.95 REF | |
| T1033-1 | 10 | 1.50±0.10 | 2.30±0.10 | 0.50 BSC | MO229 / WEED-3 | 0.25±0.05 | 2.00 REF | |
| T1033-2 | 10 | 1.50±0.10 | 2.30±0.10 | 0.50 BSC | MO229 / WEED-3 | 0.25±0.05 | 2.00 REF | |
| T1433-1 | 14 | 1.70±0.10 | 2.30±0.10 | 0.40 BSC | ---- | 0.20±0.05 | 2.40 REF | |
| T1433-2 | 14 | 1.70±0.10 | 2.30±0.10 | 0.40 BSC | ---- | 0.20±0.05 | 2.40 REF | |

NOTES:

1. ALL DIMENSIONS ARE IN mm. ANGLES IN DEGREES.
 2. COPLANARITY SHALL NOT EXCEED 0.08 mm.
 3. WARPAGE SHALL NOT EXCEED 0.10 mm.
 4. PACKAGE LENGTH/PACKAGE WIDTH ARE CONSIDERED AS SPECIAL CHARACTERISTIC(S).
 5. DRAWING CONFORMS TO JEDEC MO229, EXCEPT DIMENSIONS "D2" AND "E2", AND T1433-1 & T1433-2.
 6. "N" IS THE TOTAL NUMBER OF LEADS.
 7. NUMBER OF LEADS SHOWN ARE FOR REFERENCE ONLY.
- ⚠** MARKING IS FOR PACKAGE ORIENTATION REFERENCE ONLY.

-DRAWING NOT TO SCALE-

| | | | |
|---|----------------------|------|-----|
|  | | | |
| TITLE: PACKAGE OUTLINE, 6,8,10 & 14L, TDFN, EXPOSED PAD, 3x3x0.80 mm | | | |
| APPROVAL | DOCUMENT CONTROL NO. | REV. | 2/2 |
| | 21-0137 | I | |

Single-Input 1-Cell Li+ Charger with OVP Protection and Programmable Charge Timer

Revision History

| REVISION NUMBER | REVISION DATE | DESCRIPTION | PAGES CHANGED |
|-----------------|---------------|--------------------------|---------------|
| 0 | 1/08 | Initial release | — |
| 1 | 1/09 | Corrected various errors | 1-4, 6, 7 |

Maxim cannot assume responsibility for use of any circuitry other than circuitry entirely embodied in a Maxim product. No circuit patent licenses are implied. Maxim reserves the right to change the circuitry and specifications without notice at any time.

12 _____ **Maxim Integrated Products, 120 San Gabriel Drive, Sunnyvale, CA 94086 408-737-7600**

Mouser Electronics

Authorized Distributor

Click to View Pricing, Inventory, Delivery & Lifecycle Information:

[Maxim Integrated:](#)

[MAX8600ETD+T](#) [MAX8601ETD+T](#) [MAX8600AETD+T](#) [MAX8601ETD/V+T](#)