

Minimum order unit (pcs.)	Japan	100
	Export	5,000

3D CAD (STEP) [↓](#)

Certificate of Compliance to RoHS regulations [↓](#)

Photo



Dimensions

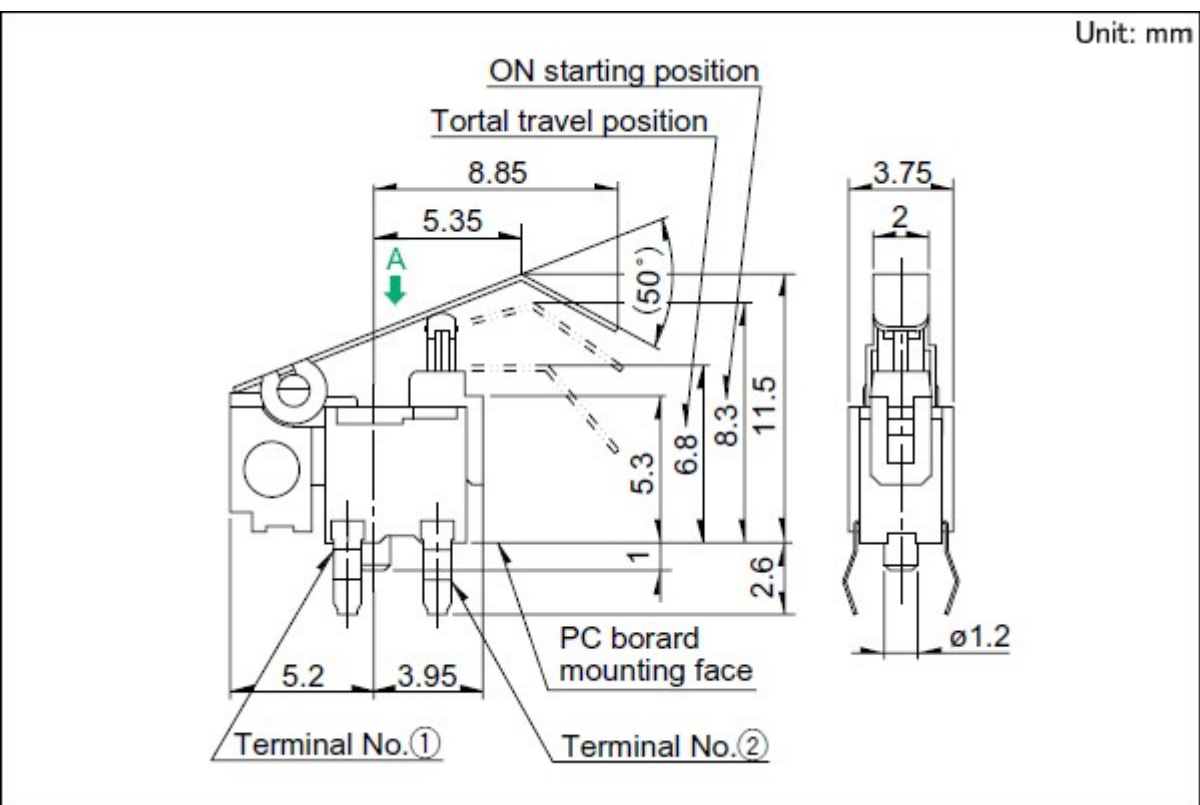

Mounting Hole Dimensions

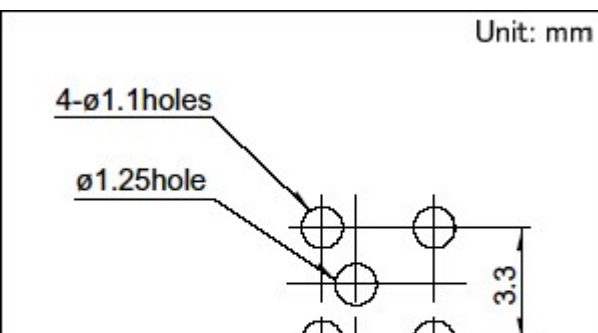

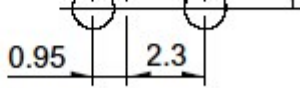

Viewed from direction A in the dimensions.

Circuit Diagram

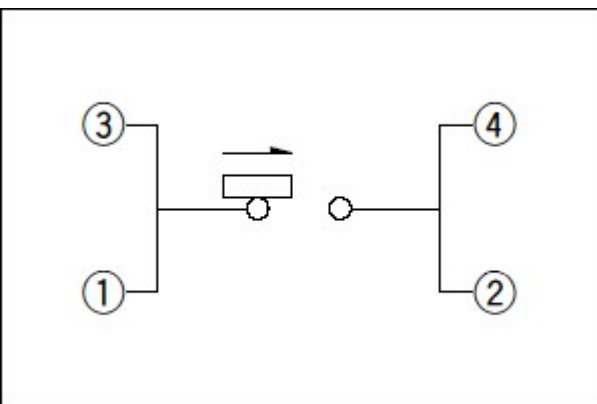

Packing Specifications

Bulk

Number of packages 1 case / Japan 1,000
(pcs.)

1 case / export
packing 5,000

Export package measurements (mm) 400×270×290

Soldering Conditions

Reference for Dip Soldering

Items Preheating temperature 100°Cmax.

Preheating time 60s max.

Dip soldering Soldering temperature 255±5°C

Duration of immersion 5±1s

Reference for Hand Soldering

Soldering temperature 350±5°C

Soldering time 5s max.

Notes are common to this series/models.

1. This site catalog shows only outline specifications. When using the products, please obtain formal specifications for supply.

2. Please place purchase orders per minimum order unit (integer).

3. This products can be used in vehicles.

Although these products are designed to perform over a wide operating temperature range, please ensure that you receive and read the formal delivery specifications before use.

Inquiries about Products

 **Inquiry**

Mouser Electronics

Authorized Distributor

Click to View Pricing, Inventory, Delivery & Lifecycle Information:

[Alps Alpine:](#)

[SPPB5A0100](#)