

Offline and DC-DC PWM Controllers for High-Brightness LED Drivers

ABSOLUTE MAXIMUM RATINGS

| | |
|---|-----------------------------------|
| IN to GND | -0.3V to +30V |
| V _{CC} to GND | -0.3V to +13V |
| DIM/FB, COMP, UVLO, CS to GND | -0.3V to +6V |
| NDRV to GND | -0.3V to (V _{CC} + 0.3V) |
| Continuous Power Dissipation (T _A = +70°C) | |
| 8-Pin μ MAX (derate 4.5mW/°C above +70°C) | 362mW |

| | |
|-----------------------------------|-----------------|
| Operating Temperature Range | -40°C to +85°C |
| Storage Temperature Range | -65°C to +150°C |
| Junction Temperature | +150°C |
| Lead Temperature (soldering, 10s) | +300°C |

Stresses beyond those listed under "Absolute Maximum Ratings" may cause permanent damage to the device. These are stress ratings only, and functional operation of the device at these or any other conditions beyond those indicated in the operational sections of the specifications is not implied. Exposure to absolute maximum rating conditions for extended periods may affect device reliability.

ELECTRICAL CHARACTERISTICS

(V_{IN} = +12V (MAX16801: V_{IN} must first be brought up to +23.6V for startup), 10nF bypass capacitors at IN and V_{CC}, C_{NDRV} = 0 μ F, V_{UVLO} = +1.4V, V_{DIM/FB} = +1.0V, COMP = unconnected, V_{CS} = 0V, T_A = -40°C to +85°C, unless otherwise noted. Typical values are at T_A = +25°C.) (Note 1)

| PARAMETER | SYMBOL | CONDITIONS | MIN | TYP | MAX | UNITS |
|---|-----------------------|--|-------|------|-------|----------|
| UNDERVOLTAGE LOCKOUT/STARTUP | | | | | | |
| Bootstrap UVLO Wake-Up Level | V _{SUVR} | V _{IN} rising (MAX16801 only) | 19.68 | 21.6 | 23.60 | V |
| Bootstrap UVLO Shutdown Level | V _{SUVF} | V _{IN} falling (MAX16801 only) | 9.05 | 9.74 | 10.43 | V |
| UVLO/EN Wake-Up Threshold | V _{ULR2} | UVLO/EN rising | 1.188 | 1.28 | 1.371 | V |
| UVLO/EN Shutdown Threshold | V _{ULF2} | UVLO/EN falling | 1.168 | 1.23 | 1.291 | V |
| UVLO/EN Input Current | I _{UVLO} | T _J = +125°C | | 25 | | nA |
| UVLO/EN Hysteresis | | | | 50 | | mV |
| IN Supply Current In Undervoltage Lockout | I _{START} | V _{IN} = +19V, for MAX16801 only when in bootstrap UVLO | | 45 | 90 | μ A |
| IN Voltage Range | V _{IN} | | 10.8 | | 24 | V |
| UVLO/EN Propagation Delay | t _{EXTR} | UVLO/EN steps up from +1.1V to +1.4V | | 12 | | μ s |
| | t _{EXTF} | UVLO/EN steps down from +1.4V to +1.1V | | 1.8 | | |
| Bootstrap UVLO Propagation Delay | t _{BUVR} | V _{IN} steps up from +9V to +24V | | 5 | | μ s |
| | t _{BUVF} | V _{IN} steps down from +24V to +9V | | 1 | | |
| INTERNAL SUPPLY | | | | | | |
| V _{CC} Regulator Set Point | V _{CCSP} | V _{IN} = +10.8V to +24V, sinking 1 μ A to 20mA from V _{CC} | 7 | | 10.5 | V |
| IN Supply Current After Startup | I _{IN} | V _{IN} = +24V | | 1.4 | 2.5 | mA |
| Shutdown Supply Current | | UVLO/EN = low | | | 90 | μ A |
| GATE DRIVER | | | | | | |
| Driver Output Impedance | R _{ON(LOW)} | Measured at NDRV sinking, 100mA | | 2 | 4 | Ω |
| | R _{ON(HIGH)} | Measured at NDRV sourcing, 20mA | | 4 | 12 | |
| Driver Peak Sink Current | | | | 1 | | A |
| Driver Peak Source Current | | | | 0.65 | | A |
| PWM COMPARATOR | | | | | | |
| Comparator Offset Voltage | V _{OPWM} | V _{COMP} - V _{CS} | 1.15 | 1.38 | 1.70 | V |
| CS Input Bias Current | I _{CS} | V _{CS} = 0V | -2 | | +2 | μ A |
| Comparator Propagation Delay | t _{PWM} | V _{CS} = +0.1V | | 60 | | ns |
| Minimum On-Time | t _{ON(MIN)} | | | 150 | | ns |

Offline and DC-DC PWM Controllers for High-Brightness LED Drivers

MAX16801A/B/MAX16802A/B

ELECTRICAL CHARACTERISTICS (continued)

($V_{IN} = +12V$ (MAX16801: V_{IN} must first be brought up to +23.6V for startup), 10nF bypass capacitors at IN and V_{CC} , $C_{NDRV} = 0\mu F$, $V_{UVLO} = +1.4V$, $V_{DIM/FB} = +1.0V$, COMP = unconnected, $V_{CS} = 0V$, $T_A = -40^\circ C$ to $+85^\circ C$, unless otherwise noted. Typical values are at $T_A = +25^\circ C$.) (Note 1)

| PARAMETER | SYMBOL | CONDITIONS | MIN | TYP | MAX | UNITS |
|---|-----------|--|-------|--------|-------|--------------|
| CURRENT-SENSE COMPARATOR | | | | | | |
| Current-Sense Trip Threshold | V_{CS} | | 262 | 291 | 320 | mV |
| CS Input Bias Current | I_{CS} | $V_{CS} = 0V$ | -2 | | +2 | μA |
| Propagation Delay From Comparator Input to NDRV | t_{PWM} | 50mV overdrive | | 60 | | ns |
| Switching Frequency | f_{SW} | | 230 | 262 | 290 | kHz |
| Maximum Duty Cycle | D_{MAX} | MAX1680_A | | 50 | 50.5 | % |
| | | MAX1680_B | | 75 | 76 | |
| IN CLAMP VOLTAGE | | | | | | |
| IN Clamp Voltage | V_{INC} | 2mA sink current, MAX16801 only (Note 3) | 24.1 | 26.1 | 29.0 | V |
| ERROR AMPLIFIER | | | | | | |
| Voltage Gain | | $R_{LOAD} = 100k\Omega$ | | 80 | | dB |
| Unity-Gain Bandwidth | | $R_{LOAD} = 100k\Omega$, $C_{LOAD} = 200pF$ | | 2 | | MHz |
| Phase Margin | | $R_{LOAD} = 100k\Omega$, $C_{LOAD} = 200pF$ | | 65 | | Degrees |
| DIM/FB Input Offset Voltage | | | | | 3 | mV |
| COMP Clamp Voltage | | High | 2.2 | | 3.5 | V |
| | | Low | 0.4 | | 1.1 | |
| Source Current | | | 0.5 | | | mA |
| Sink Current | | | 0.5 | | | mA |
| Reference Voltage | V_{REF} | (Note 2) | 1.218 | 1.230 | 1.242 | V |
| Input Bias Current | | | | | 50 | nA |
| COMP Short-Circuit Current | | | | 8 | | mA |
| THERMAL SHUTDOWN | | | | | | |
| Thermal-Shutdown Temperature | | | | 130 | | $^\circ C$ |
| Thermal Hysteresis | | | | 25 | | $^\circ C$ |
| DIGITAL SOFT-START | | | | | | |
| Soft-Start Duration | | | | 15,872 | | Clock cycles |
| Reference Voltage Steps During Soft-Start | | | | 31 | | Steps |
| Reference Voltage Step | | | | 40 | | mV |

Note 1: All devices are 100% tested at $T_A = +85^\circ C$. All limits over temperature are guaranteed by characterization.

Note 2: V_{REF} is measured with DIM/FB connected to the COMP pin (see the *Functional Diagram*).

Note 3: The MAX16801 is intended for use in universal input offline drivers. The internal clamp circuit is used to prevent the bootstrap capacitor (C1 in Figure 5) from charging to a voltage beyond the absolute maximum rating of the device when EN/UVLO is low. The maximum current to IN (hence to clamp) when UVLO is low (device in shutdown), must be externally limited to 2mA (max). Clamp currents higher than 2mA may result in clamp voltage higher than +30V, thus exceeding the absolute maximum rating for IN. For the MAX16802, do not exceed the +24V maximum operating voltage of the device.

Offline and DC-DC PWM Controllers for High-Brightness LED Drivers

Typical Operating Characteristics

($V_{UVLO/EN} = +1.4V$, $V_{FB} = +1V$, COMP = unconnected, $V_{CS} = 0V$, $T_A = +25^\circ C$, unless otherwise noted.)

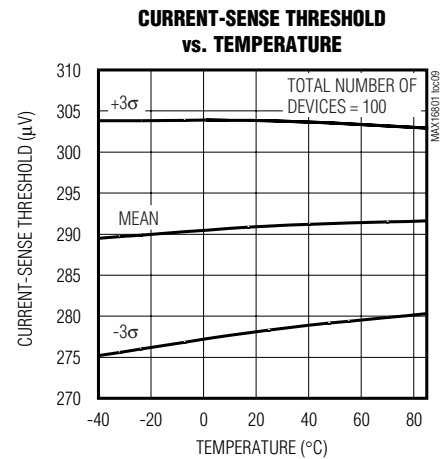
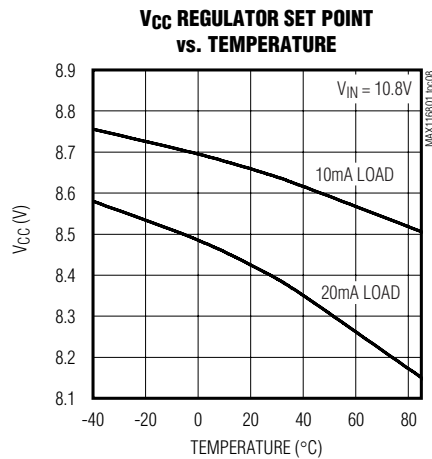
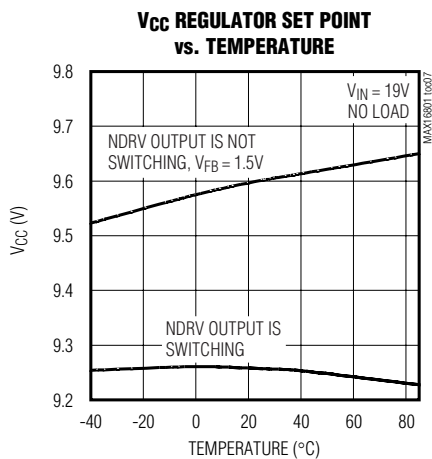
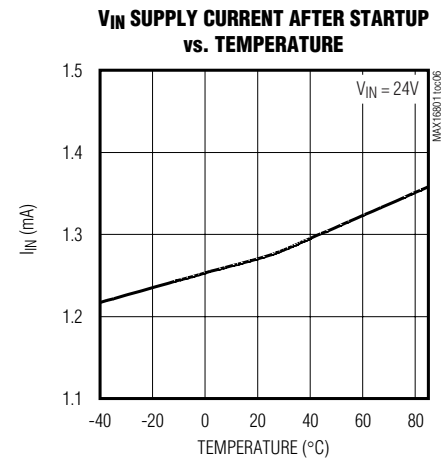
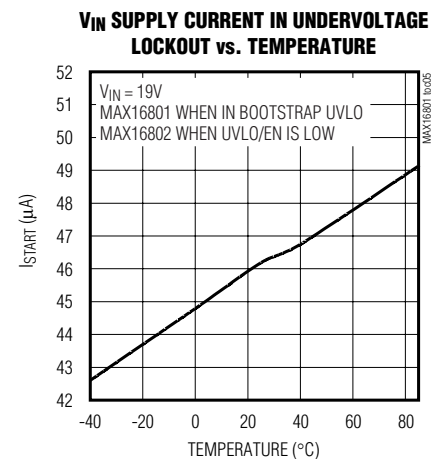
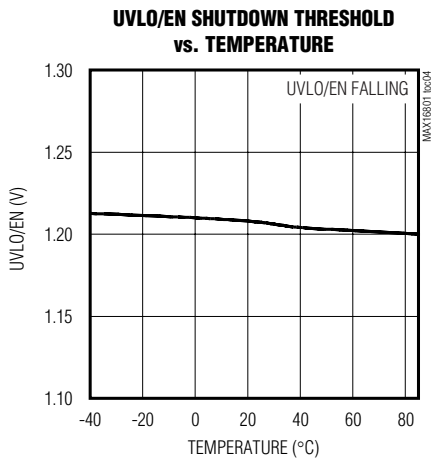
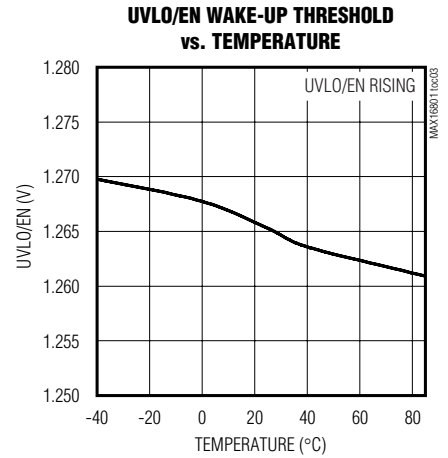
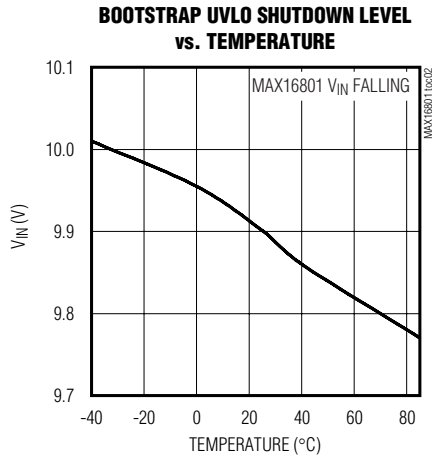
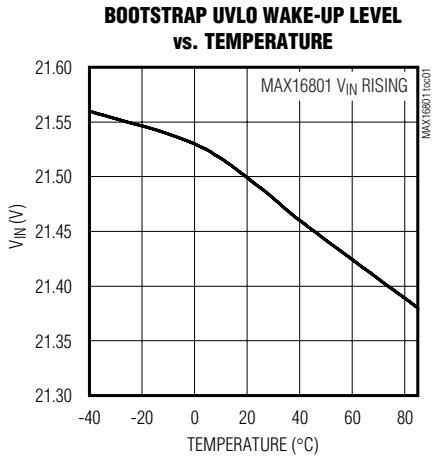

Offline and DC-DC PWM Controllers for High-Brightness LED Drivers

Typical Operating Characteristics (continued)

($V_{UVLO/EN} = +1.4V$, $V_{FB} = +1V$, COMP = unconnected, $V_{CS} = 0V$, $T_A = +25^\circ C$, unless otherwise noted.)

MAX16801A/B/MAX16802A/B

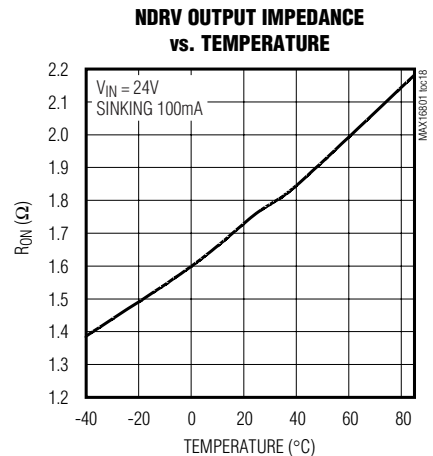
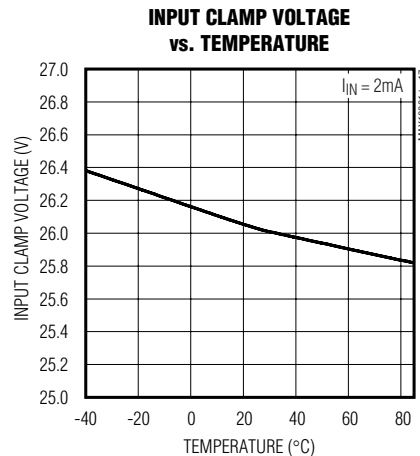
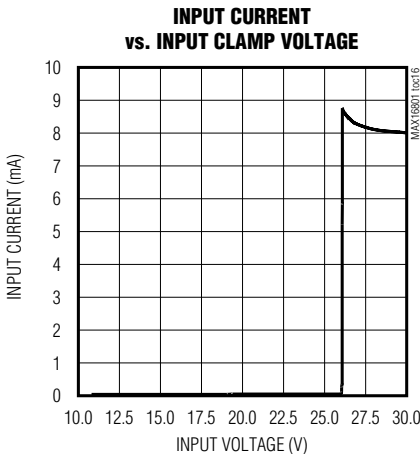
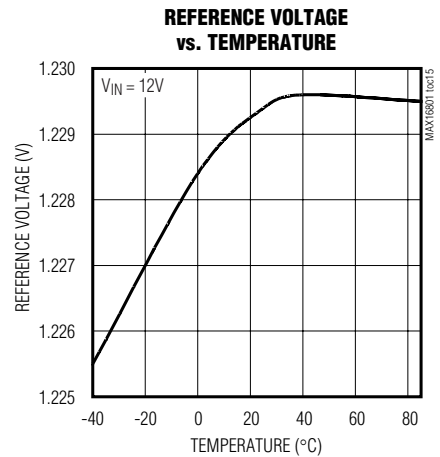
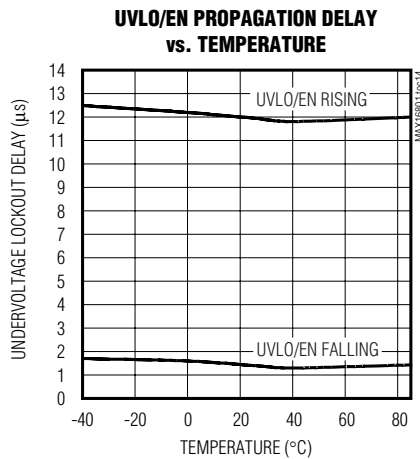
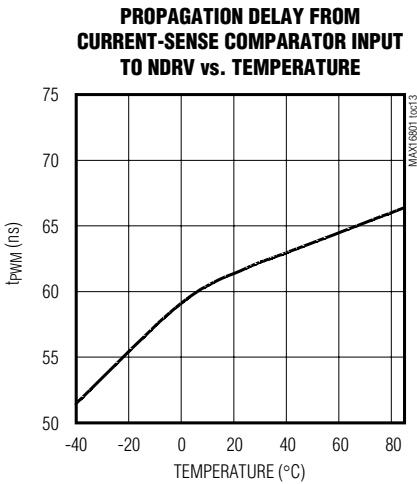
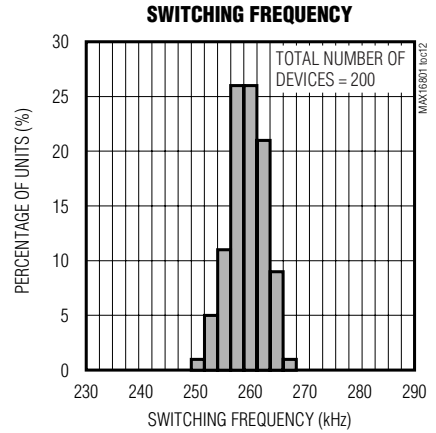
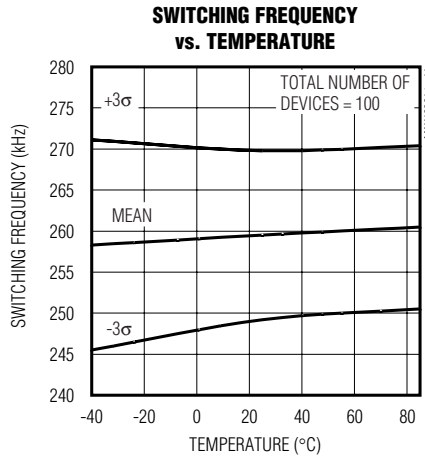
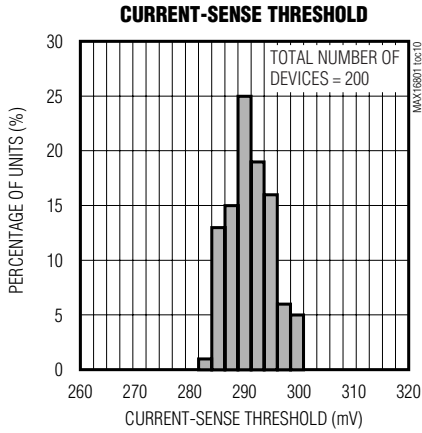

Offline and DC-DC PWM Controllers for High-Brightness LED Drivers

Typical Operating Characteristics (continued)

($V_{UVLO/EN} = +1.4V$, $V_{FB} = +1V$, COMP = unconnected, $V_{CS} = 0V$, $T_A = +25^\circ C$, unless otherwise noted.)

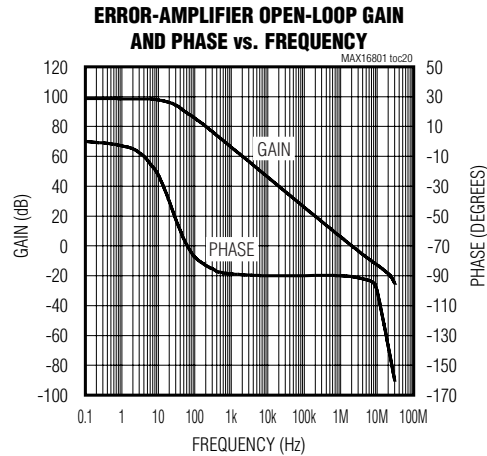
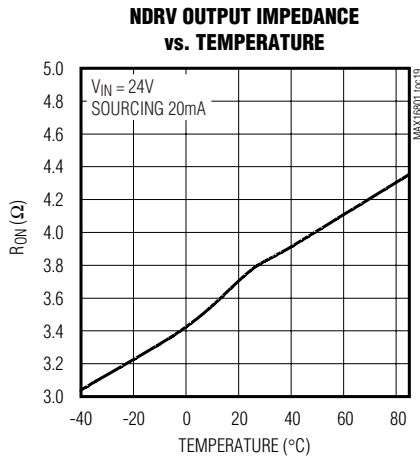

Pin Description

| PIN | NAME | FUNCTION |
|-----|---------|---|
| 1 | UVLO/EN | Externally Programmable Undervoltage Lockout. UVLO programs the input start voltage. Connect UVLO to GND to disable the device. |
| 2 | DIM/FB | Low-Frequency PWM Dimming Input/Error-Amplifier Inverting Input |
| 3 | COMP | Error-Amplifier Output. Connect the compensation components between DIM/FB and COMP in high-accuracy LED current regulation. |
| 4 | CS | Current-Sense Connection for Current Regulation. Connect to high side of sense resistor. An RC filter may be necessary to eliminate leading-edge spikes. |
| 5 | GND | Power-Supply Ground |
| 6 | NDRV | External n-Channel MOSFET Gate Connection |
| 7 | VCC | Gate-Drive Supply. Internally regulated down from IN. Decouple with a 10nF or larger capacitor to GND. |
| 8 | IN | IC Supply. Decouple with a 10nF or larger capacitor to GND. For bootstrapped operation (MAX16801), connect a startup resistor from the input supply line to IN. Connect the bias winding supply to this point (see Figure 5). For the MAX16802, connect IN directly to a +10.8V to +24V supply. |

Detailed Description

The MAX16801/MAX16802 family of devices is intended for constant current drive of high-brightness (HB) LEDs used in general lighting and display applications. They are specifically designed for use in isolated and nonisolated circuit topologies such as buck, boost, flyback, and SEPIC, operating in continuous or discontinuous mode. Current mode control is implemented with an internally trimmed, fixed 262kHz switching frequency. A bootstrap UVLO with a large hysteresis (11.9V), very low startup current, and low operating current

result in an efficient universal-input LED driver. In addition to the internal bootstrap UVLO, these devices also offer programmable input startup voltage programmed through the UVLO/EN pin. The MAX16801 is well suited for universal AC input (rectified 85VAC to 265VAC) drivers. The MAX16802 is well suited for low input voltage (10.8VDC to 24VDC) applications.

The MAX16801/MAX16802 regulate the LED current by monitoring current through the external MOSFET cycle by cycle.

Offline and DC-DC PWM Controllers for High-Brightness LED Drivers

When in the bootstrapped mode with a transformer (Figure 5), the circuit is protected against most output short-circuit faults when the tertiary voltage drops below +10V, causing the UVLO to turn off the gate drive of the external MOSFET. This re-initiates a startup sequence with soft-start.

When the LED current needs to be tightly regulated, an internal error amplifier with 1% accurate reference can be used (Figure 9). This additional feedback minimizes the impact of passive circuit component variations and tolerances, and can be implemented with a minimum number of additional external components.

A wide dimming range can be implemented using a low-frequency PWM dimming signal fed directly to the DIM/FB pin.

LED driver circuits designed with the MAX16801 use a high-value startup resistor R1 that charges a reservoir capacitor C1 (Figure 5 or Figure 9). During this initial period, while the voltage is less than the internal bootstrap UVLO threshold, the device typically consumes only 45µA of quiescent current. This low startup current and the large bootstrap UVLO hysteresis help minimize

the power dissipation across R1, even at the high end of the universal AC input voltage.

An internal shutdown circuit protects the device whenever the junction temperature exceeds +130°C (typ).

Dimming

Linear dimming can be implemented by creating a summing node at CS, as shown in Figures 6 and 7.

Low-frequency PWM (chopped-current) dimming is possible by applying an inverted-logic PWM signal to the DIM/FB pin of the IC (Figure 8). This might be a preferred way of dimming in situations where it is critical to retain the light spectrum unchanged. It is accomplished by keeping constant the amplitude of the chopped LED current.

MAX16801/MAX16802 Biasing

Implement bootstrapping from the transformer when it is present (Figure 5). Biasing can also be realized directly from the LEDs in non-isolated topologies (Figure 1).

Bias the MAX16802 directly from the input voltage of 10.8VDC to 24VDC. The MAX16802 can also be used

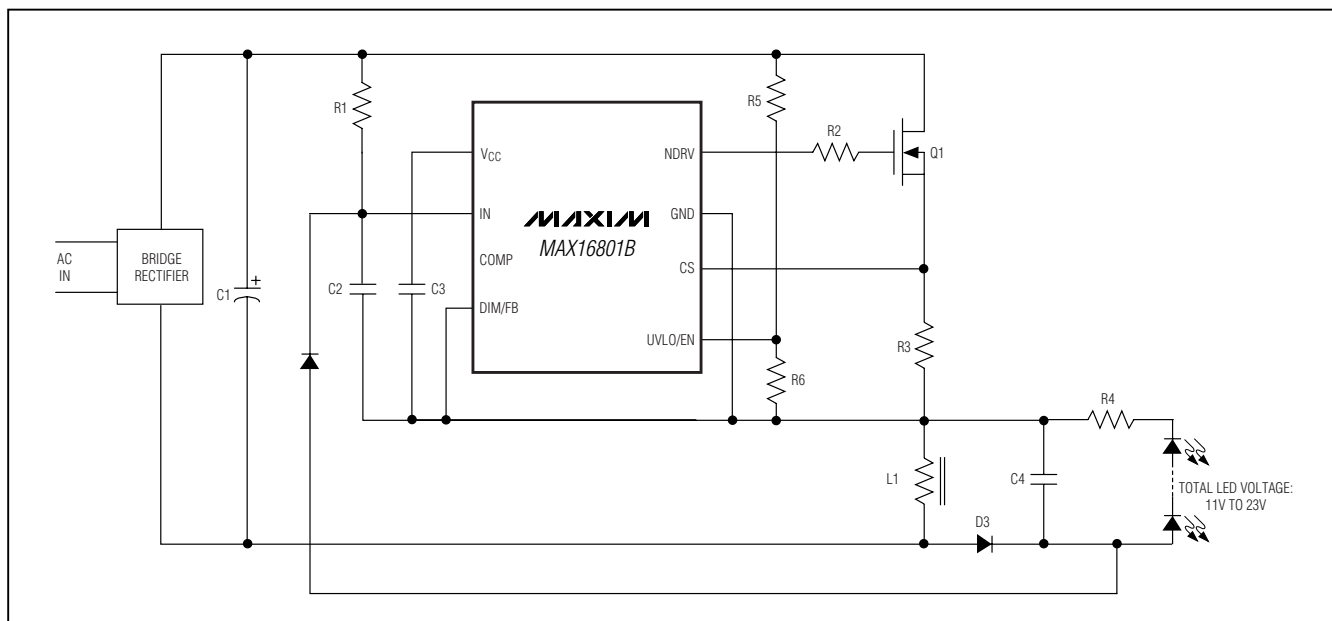

Figure 1. Biasing the IC using LEDs in Nonisolated Flyback Driver

Offline and DC-DC PWM Controllers for High-Brightness LED Drivers

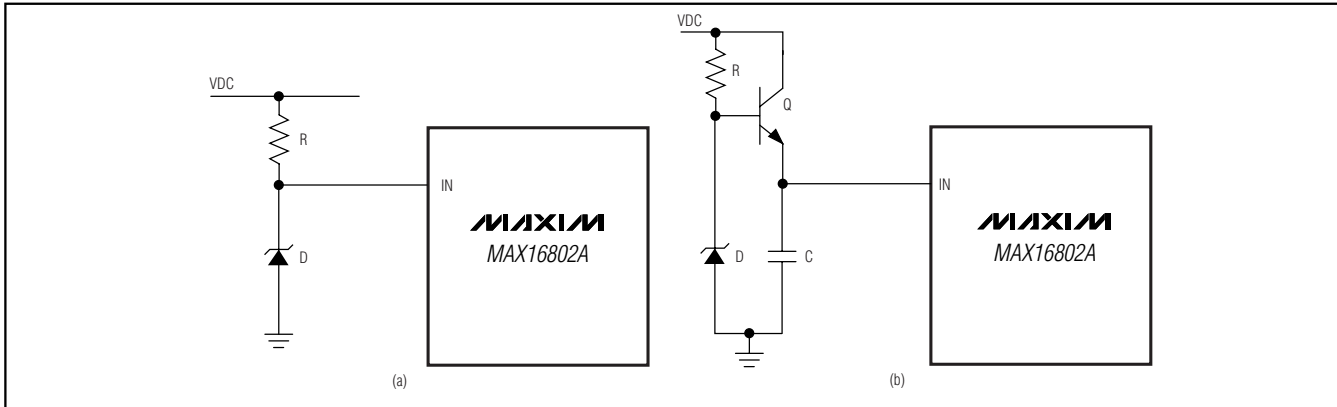

Figure 2. (a) Resistor-Zener and (b) Transistor-Zener-Resistor Bias Arrangements

in applications with higher input DC voltages by implementing resistor-Zener bias (Figure 2a) or transistor-Zener-resistor bias (Figure 2b).

MAX16801/MAX16802 Undervoltage Lockout

The MAX16801/MAX16802 have an input voltage UVLO/EN pin. The threshold of this UVLO is +1.28V. Before any operation can commence, the voltage on this pin has to exceed +1.28V. The UVLO circuit keeps the CPWM comparator, ILIM comparator, oscillator, and output driver in shutdown to reduce current consumption (see the *Functional Diagram*). Use this UVLO function to program the input start voltage. Calculate the divider resistor values, R2 and R3 (Figure 5), by using the following formulas:

$$R3 \cong \frac{V_{ULR2} \times V_{IN}}{500 \times I_{UVLO}(V_{IN} - V_{ULR2})}$$

The value of R3 is calculated to minimize the voltage-drop error across R2 as a result of the input bias current of the UVLO/EN pin. $V_{ULR2} = +1.28V$, $I_{UVLO} = 50nA$ (max), V_{IN} is the value of the input-supply voltage where the power supply must start.

$$R2 = \frac{V_{IN} - V_{ULR2}}{V_{ULR2}} \times R3$$

where I_{UVLO} is the UVLO/EN pin input current, and V_{ULR2} is the UVLO/EN wake-up threshold.

MAX16801 Bootstrap Undervoltage Lockout

In addition to the externally programmable UVLO function offered in both the MAX16801/MAX16802, the MAX16801 has an additional internal bootstrap UVLO that is very useful when designing high-voltage LED drivers (see the *Functional Diagram*). This allows the device to bootstrap itself during initial power-up. The MAX16801 attempts to start when V_{IN} exceeds the bootstrap UVLO threshold of +23.6V. During startup, the UVLO circuit keeps the CPWM comparator, ILIM comparator, oscillator, and output driver shut down to reduce current consumption. Once V_{IN} reaches +23.6V, the UVLO circuit turns on both the CPWM and ILIM comparators, as well as the oscillator, and allows the output driver to switch. If V_{IN} drops below +9.7V, the UVLO circuit will shut down the CPWM comparator, ILIM comparator, oscillator, and output driver thereby returning the MAX16801 to the startup mode.

MAX16801 Startup Operation

In isolated LED driver applications, V_{IN} can be derived from a tertiary winding of a transformer. However, at startup there is no energy delivered through the transformer. Therefore, a special bootstrap sequence is required. Figure 3 shows the voltages on IN and VCC during startup. Initially, both V_{IN} and V_{CC} are 0V. After the line voltage is applied, C1 charges through the startup resistor R1 to an intermediate voltage. At this point, the internal regulator begins charging C2 (see Figure 5). The MAX16801 uses only 45 μA of the current supplied by R1, and the remaining input current charges C1 and C2. The charging of C2 stops when the V_{CC} voltage reaches approximately +9.5V, while the voltage across C1 continues rising until it reaches

Offline and DC-DC PWM Controllers for High-Brightness LED Drivers

Soft-Start

The MAX16801/MAX16802 soft-start feature allows the LED current to ramp up in a controlled manner. Soft-start begins after UVLO deasserts. The voltage applied to the noninverting node of the amplifier ramps from 0 to +1.23V over a 60ms soft-start timeout period. Figure 4 shows a typical 0.5A output current during startup. Note the staircase increase of the LED current. This is a result of the digital soft-starting technique used. Unlike other devices, the reference voltage to the internal amplifier is soft-started. This method results in superior control of the LED current.

n-Channel MOSFET Switch Driver

The NDRV pin drives an external n-channel MOSFET. The NDRV output is supplied by the internal regulator (V_{CC}), which is internally set to approximately +9.5V. For the universal input voltage and applications with a transformer, the MOSFET used must be able to withstand the DC level of the high-line input voltage plus the reflected voltage at the primary of the transformer. For most offline applications that use the discontinuous flyback topology, this requires a MOSFET rated at 600V. NDRV can source/sink in excess of the 650mA/1000mA peak current. Select a MOSFET that yields acceptable conduction and switching losses.

Internal Error Amplifier

The MAX16801/MAX16802 include an internal error amplifier that can be used to regulate the LED current very accurately. For example, see the nonisolated power supply in Figure 5. Calculate the LED current using the following equation:

$$I_{LED} = \frac{V_{REF}}{R7}$$

where V_{REF} = +1.23V. The amplifier's noninverting input is internally connected to a digital soft-start circuit that gradually increases the reference voltage during startup and is applied to this pin. This forces the LED current to come up in an orderly and well-defined manner under all conditions.

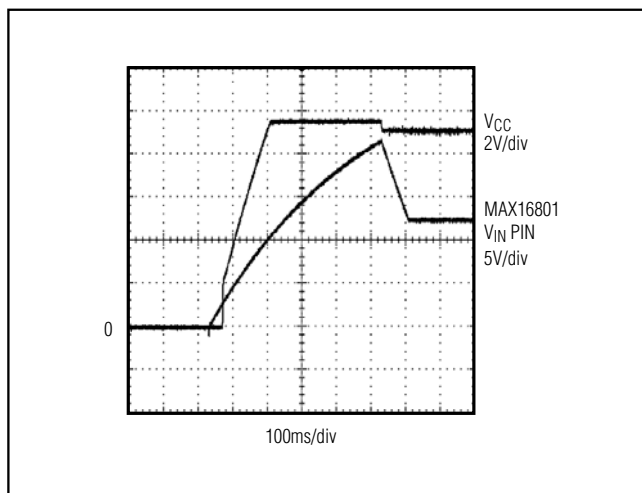

Figure 3. V_{IN} and V_{CC} During Startup when Using the MAX16801 in Bootstrapped Mode

the wake-up level of +23.6V. Once V_{IN} exceeds the bootstrap UVLO threshold, NDRV begins switching the MOSFET and transfers energy to the secondary and tertiary outputs. If the voltage on the tertiary output builds to a value higher than +9.7V (the bootstrap UVLO lower threshold), then startup has been accomplished and sustained operation commences.

If V_{IN} drops below +9.7V before startup is complete, the device goes back to low-current UVLO. In this case, increase C1 in order to store enough energy to allow for the voltage at the tertiary winding to build up.

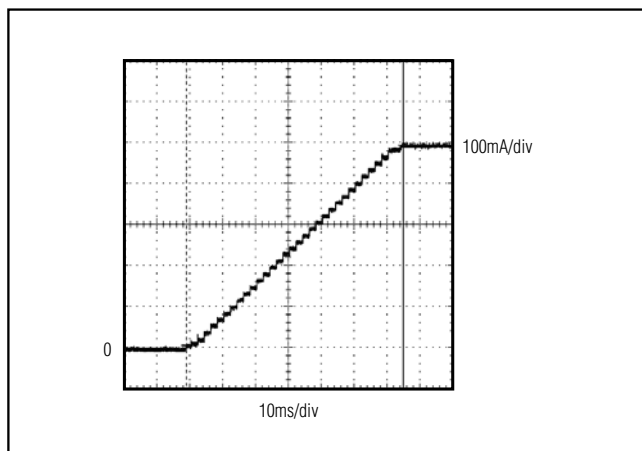

Figure 4. Typical Current Soft-Start During Initial Startup

Offline and DC-DC PWM Controllers for High-Brightness LED Drivers

Applications Information

Startup Time Considerations for High-Brightness LED Drivers Using MAX16801

The IN bypass capacitor C1 supplies current immediately after wake-up (Figure 5). The size of C1 and the connection configuration of the tertiary winding determine the number of cycles available for startup. Large values of C1 increase the startup time but also supply gate charge for more cycles during initial startup. If the value of C1 is too small, V_{IN} drops below +9.7V because NDRV does not have enough time to switch and build up sufficient voltage across the tertiary winding that powers the device. The device goes back into UVLO and does not start. Use low-leakage capacitors for C1 and C2.

Assuming that offline LED drivers keep typical startup times to less than 500ms even in low-line conditions (85VAC input for universal offline applications), size the startup resistor R1 to supply both the maximum startup bias of the device (90 μ A, worst case) and the charging current for C1 and C2. The bypass capacitor C2 must charge to +9.5V and C1 to +24V, all within the desired time period of 500ms.

Because of the internal 60ms soft-start time of the MAX16801, C1 must store enough charge to deliver current to the device for at least this much time. To calculate the approximate amount of capacitance required, use the following formula:

$$I_g = Q_{gtot} \times f_{sw}$$

$$C1 = \frac{(I_{IN} + I_g)(t_{SS})}{V_{HYST}}$$

where I_{IN} is the MAX16801's internal supply current after startup (1.4mA), Q_{gtot} is the total gate charge for Q1, f_{sw} is the MAX16801's switching frequency (262kHz), V_{HYST} is the bootstrap UVLO hysteresis (11.9V) and t_{SS} is the internal soft-start time (60ms).

For example:

$$I_g = (8nC) \times (262kHz) = 2.1mA$$

$$C1 = \frac{(1.4mA + 2.1mA) \times (60ms)}{(12V)} = 17.5\mu F$$

Choose the 15 μ F standard value.

Assuming $C1 > C2$, calculate the value of R1 as follows:

$$I_{C1} = \frac{V_{SUVR} \times C1}{(500ms)}$$

$$R1 = \frac{V_{IN(MIN)} - V_{SUVR}}{I_{C1} + I_{START}}$$

where $V_{IN(MIN)}$ is the minimum input supply voltage for the application, V_{SUVR} is the bootstrap UVLO wake-up level (+23.6V, max), and I_{START} is the IN supply current at startup (90 μ A, max).

For example, for the minimum AC input of 85V:

$$I_{C1} = \frac{(24V) \times (15\mu F)}{(500ms)} = 0.72mA$$

$$R1 = \frac{120V - 24V}{(0.72mA + (90\mu A))} = 119k\Omega$$

Choose the 120k Ω standard value.

Choose a higher value for R1 than the one calculated above if longer startup time can be tolerated in order to minimize power loss on this resistor.

The above startup method is applicable to a circuit similar to the one shown in Figure 5. In this circuit, the tertiary winding has the same phase as the output windings. Thus, the voltage on the tertiary winding at any given time is proportional to the output voltage and goes through the same soft-start period as the output voltage. The minimum discharge voltage of C1 from +22V to +10V must be greater than the soft-start time of 60ms.

Another method of bootstrapping the circuit is to have a separate bias winding than the one used for regulating the output voltage and to connect the bias winding so that it is in phase with the MOSFET ON time (see Figure 9). In this case, the amount of capacitance required is much smaller.

However, in this mode, the input voltage range has to be less than 2:1. Another consideration is whether the bias winding is in phase with the output. If so, the LED driver circuit hiccups and soft-starts under output short-circuit conditions. However, this property is lost if the bias winding is in phase with the MOSFET ON time.

Offline and DC-DC PWM Controllers for High-Brightness LED Drivers

Application Circuits

Figure 5 shows an offline application of an HB LED driver using the MAX16801. The use of transformer T1 allows significant design flexibility. Use the internal error amplifier for a very accurate LED current control.

Figure 6 shows a discontinuous flyback LED driver with linear dimming capability. The total LED voltage can be lower or higher than the input voltage.

Figure 7 shows a continuous-conduction-mode HB LED buck driver with linear dimming and just a few external components.

Figure 8 shows an offline isolated flyback HB LED driver with low-frequency PWM using MAX16801. The PWM signal needs to be inverted (see the *Functional Diagram*). Transformer T1 provides full safety isolation and operation from universal AC line (85VAC to 265VAC).

MAX16801A/B/MAX16802A/B

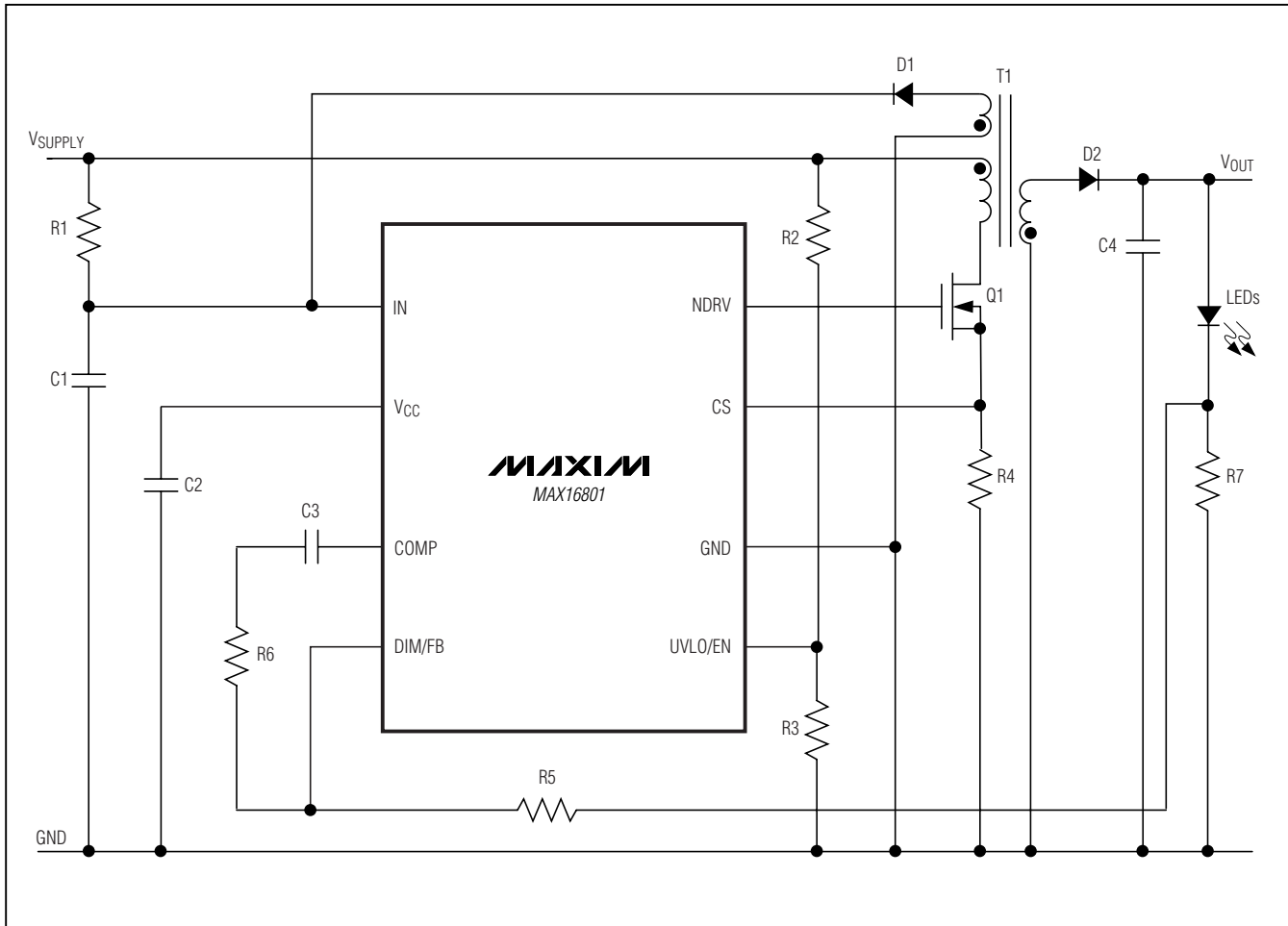

Figure 5. Offline, Nonisolated, Flyback LED Driver with Programmable Input-Supply Start Voltage

Offline and DC-DC PWM Controllers for High-Brightness LED Drivers

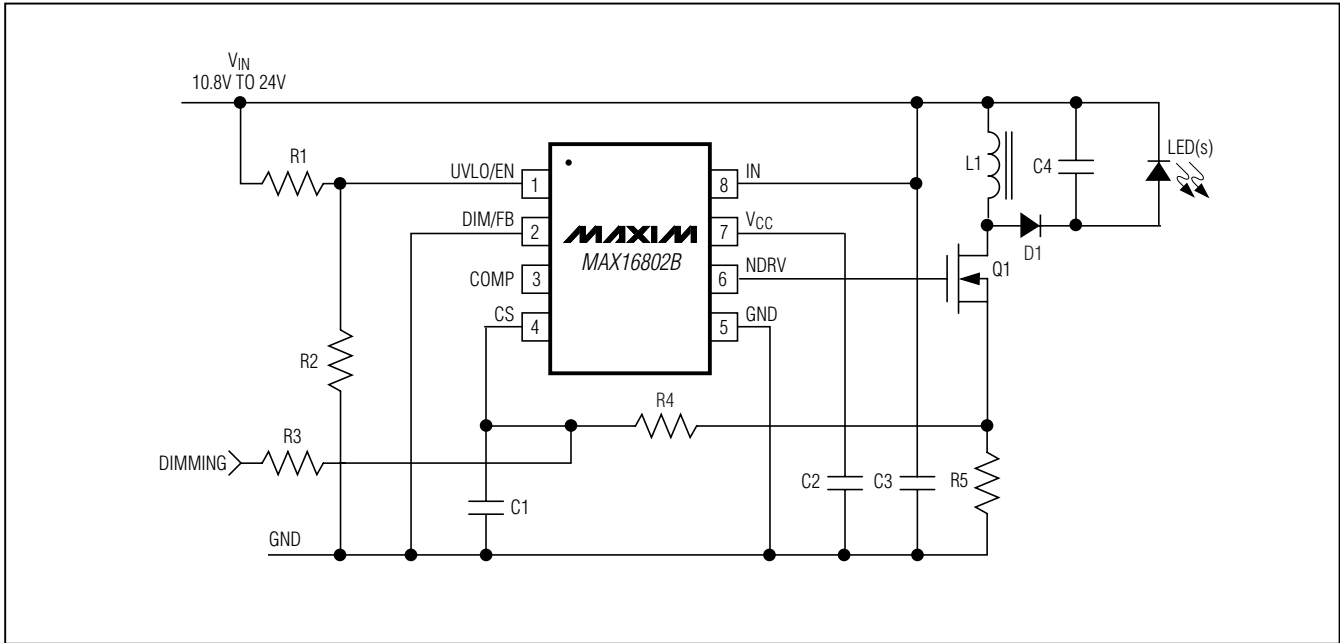

Figure 6. MAX16802 Flyback HB LED Driver with Dimming Capability, 10.8V to 24V Input Voltage Range

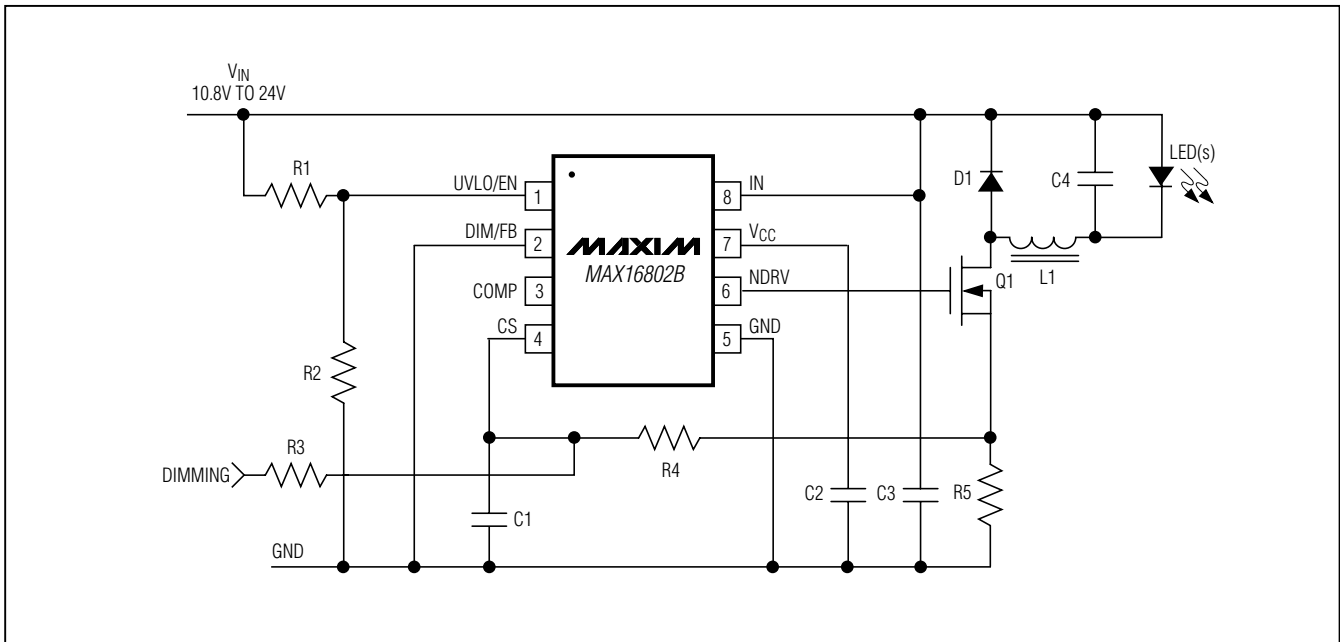

Figure 7. MAX16802 Buck HB LED Driver with Dimming Capability, 10.8V to 24V Input Voltage Range

Offline and DC-DC PWM Controllers for High-Brightness LED Drivers

MAX16801A/B/MAX16802A/B

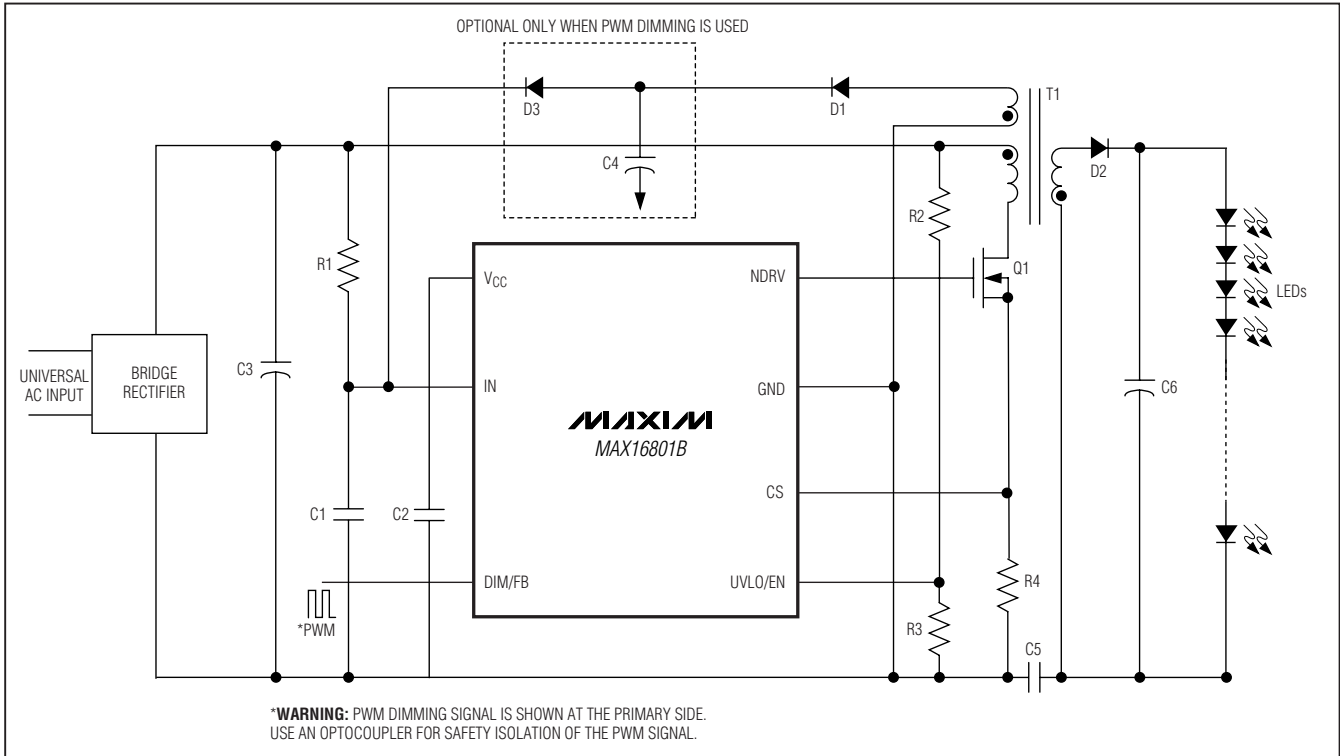

Figure 8. Universal AC Input, Offline, Isolated Flyback HB LED Driver with Low-Frequency PWM Dimming

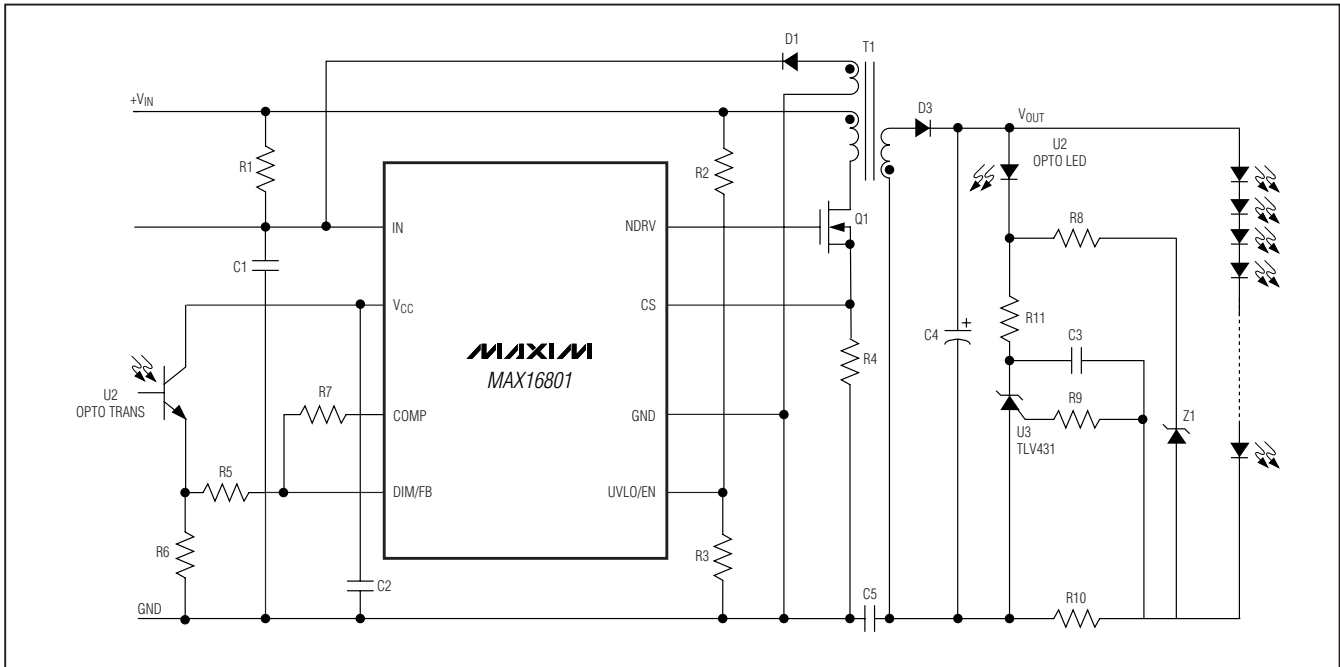
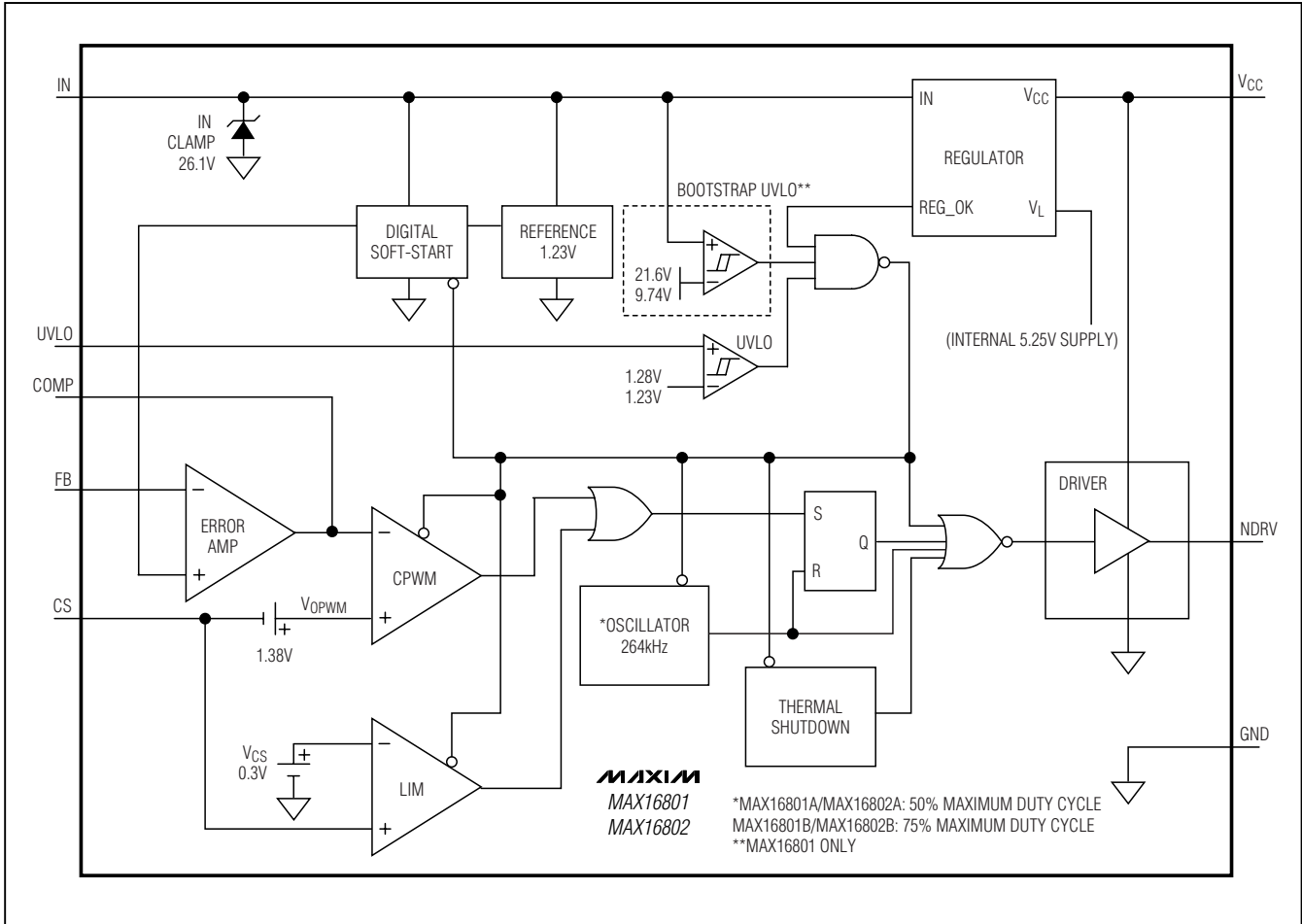

Figure 9. Universal Input, Offline, High-Accuracy Current Regulation in an Isolated Flyback HB LED Driver

Offline and DC-DC PWM Controllers for High-Brightness LED Drivers

Functional Diagram



Selector Guide

| PART | BOOTSTRAP UVLO | STARTUP VOLTAGE (V) | MAX DUTY CYCLE (%) |
|-----------|----------------|---------------------|--------------------|
| MAX16801A | Yes | 22 | 50 |
| MAX16801B | Yes | 22 | 75 |
| MAX16802A | No | 10.8* | 50 |
| MAX16802B | No | 10.8* | 75 |

*The MAX16802 does not have an internal bootstrap UVLO. The MAX16802 starts operation as long as the VCC pin is higher than +7V, (the guaranteed output with an IN pin voltage of +10.8V), and the UVLO/EN pin is high.

Pin Configuration

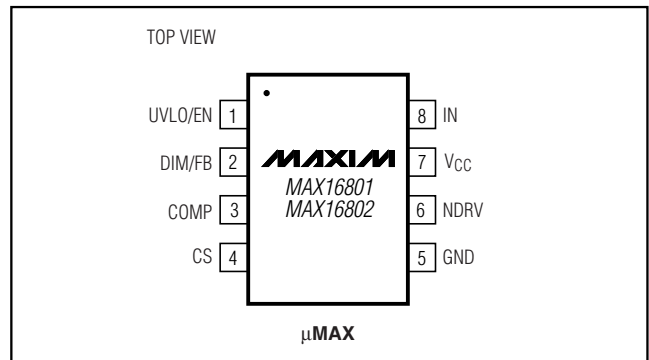

Offline and DC-DC PWM Controllers for High-Brightness LED Drivers

Package Information

For the latest package outline information and land patterns, go to www.maxim-ic.com/packages. Note that a "+", "#", or "-" in the package code indicates RoHS status only. Package drawings may show a different suffix character, but the drawing pertains to the package regardless of RoHS status.

| PACKAGE TYPE | PACKAGE CODE | DOCUMENT NO. |
|--------------|--------------|-------------------------|
| 8 μ MAX | — | 21-0036 |

MAX16801A/B/MAX16802A/B

Offline and DC-DC PWM Controllers for High-Brightness LED Drivers

Revision History

| REVISION NUMBER | REVISION DATE | DESCRIPTION | PAGES CHANGED |
|------------------------|----------------------|---|----------------------|
| 0 | 10/05 | Initial release | — |
| 1 | 1/06 | MAX16802AEUA+ parts are available | 1 |
| 2 | 1/10 | Corrected formulas, updated subscripts, and removed package outline | 1, 2, 3, 6–14 |

Maxim cannot assume responsibility for use of any circuitry other than circuitry entirely embodied in a Maxim product. No circuit patent licenses are implied. Maxim reserves the right to change the circuitry and specifications without notice at any time.

16 _____ **Maxim Integrated Products, 120 San Gabriel Drive, Sunnyvale, CA 94086 408-737-7600**

Mouser Electronics

Authorized Distributor

Click to View Pricing, Inventory, Delivery & Lifecycle Information:

Maxim Integrated:

[MAX16801AEUA+](#) [MAX16801BEUA+](#) [MAX16802AEUA+](#) [MAX16802BEUA+](#) [MAX16801AEUA+T](#)
[MAX16801BEUA+T](#) [MAX16802AEUA+T](#) [MAX16802BEUA+T](#)