

An Ultra-small 1.6 mm², 28.5 mΩ, 1.0 A,
Integrated Power Switch

Pin Description

| Pin # | Pin Name | Type | Pin Description |
|-------|----------|--------|--|
| 1 | ON | Input | A low-to-high transition on this pin initiates the operation of the SLG59M1558V. ON is an asserted HIGH, level-sensitive CMOS input with ON_V _{IL} < 0.3 V and ON_V _{IH} > 0.85 V. As the ON pin input circuit does not have an internal pull-down resistor, connect this pin to a general-purpose output (GPO) of a microcontroller, an application processor, or a system controller – do not allow this pin to be open-circuited. |
| 2 | VIN | MOSFET | Input terminal connection of the power MOSFET. Connect a 10 μF (or larger) low-ESR capacitor from this pin to ground. Capacitors used at VIN should be rated at 10 V or higher. |
| 3 | VOUT | MOSFET | Output terminal connection of the power MOSFET. Capacitors used at VOUT should be rated at 10 V or higher. |
| 4 | GND | GND | Ground connection. Connect this pin to system analog or power ground plane. |

Ordering Information

| Part Number | Type | Production Flow |
|---------------|--------------------------|-----------------------------|
| SLG59M1558V | STDFN 4L | Industrial, -40 °C to 85 °C |
| SLG59M1558VTR | STDFN 4L (Tape and Reel) | Industrial, -40 °C to 85 °C |

An Ultra-small 1.6 mm², 28.5 mΩ, 1.0 A,
Integrated Power Switch

Absolute Maximum Ratings

| Parameter | Description | Conditions | Min. | Typ. | Max. | Unit |
|----------------------------|-------------------------------|---|------|------|------|------|
| V _{IN} | Power Switch Input Voltage | | -- | -- | 6 | V |
| T _S | Storage Temperature | | -65 | -- | 140 | °C |
| T _J | Junction Temperature | | -40 | -- | 150 | °C |
| ESD _{HBM} | ESD Protection | Human Body Model | 2000 | -- | -- | V |
| θ _{JA} | Thermal Resistance | 1.0 x 1.0 mm, 4L STDFN; Determined using 1 in ² , 2 oz. copper pads under each VIN and VOUT terminals and FR4 pcb material | -- | 122 | -- | °C/W |
| W _{DIS} | Package Power Dissipation | | -- | -- | 0.5 | W |
| MOSFET I _{DSPEAK} | Peak Current from VIN to VOUT | For no more than 1 ms with 1% duty cycle | -- | -- | 1.5 | A |

Note: Stresses greater than those listed under “Absolute Maximum Ratings” may cause permanent damage to the device. This is a stress rating only and functional operation of the device at these or any other conditions above those indicated in the operational sections of this specification is not implied. Exposure to absolute maximum rating conditions for extended periods may affect reliability.

Electrical Characteristics

T_A = -40 °C to 85 °C unless otherwise noted. Typical values are at T_A = 25 °C

| Parameter | Description | Conditions | Min. | Typ. | Max. | Unit |
|------------------------|---------------------------------------|--|------|------|------|------|
| V _{IN} | Power Switch Input Voltage | -40 °C to 85 °C | 1.5 | -- | 5.5 | V |
| I _{IN} | Power Switch Input Current (PIN 2) | when OFF, V _{IN} = 5.5 V, No load | -- | 0.02 | 1 | μA |
| | | when ON, ON = V _{IN} , No load | -- | 0.05 | 0.5 | μA |
| I _{FET_OFF} | MOSFET OFF Leakage Current | ON = LOW; V _{IN} = 5.5 V | -- | 0.05 | 1 | μA |
| I _{ON_LKG} | ON Pin Input Leakage | | -- | -- | 0.1 | μA |
| R _{DS_ON} | ON Resistance, T _A = 25 °C | V _{IN} = 5.5 V, I _{DS} = 100 mA | -- | 28.5 | 32.0 | mΩ |
| | | V _{IN} = 3.3 V, I _{DS} = 100 mA | -- | 36.4 | 40.0 | mΩ |
| | | V _{IN} = 2.5 V, I _{DS} = 100 mA | -- | 44.3 | 49.0 | mΩ |
| | | V _{IN} = 1.8 V, I _{DS} = 100 mA | -- | 60.8 | 65.0 | mΩ |
| | | V _{IN} = 1.5 V, I _{DS} = 100 mA | -- | 77.6 | 82.0 | mΩ |
| R _{DS_ON} | ON Resistance, T _A = 85 °C | V _{IN} = 5.5 V, I _{DS} = 100 mA | -- | 34.0 | 36.0 | mΩ |
| | | V _{IN} = 3.3 V, I _{DS} = 100 mA | -- | 43.8 | 46.0 | mΩ |
| | | V _{IN} = 2.5 V, I _{DS} = 100 mA | -- | 53.3 | 56.0 | mΩ |
| | | V _{IN} = 1.8 V, I _{DS} = 100 mA | -- | 72.2 | 76.0 | mΩ |
| | | V _{IN} = 1.5 V, I _{DS} = 100 mA | -- | 90.7 | 94.0 | mΩ |
| MOSFET I _{DS} | Current from VIN to VOUT | Continuous | -- | -- | 1.0 | A |
| T _{ON_Delay} | ON Delay Time | 50% ON to V _{OUT} Ramp Start; V _{IN} = 5 V, C _{LOAD} = 0.1 μF, R _{LOAD} = 10 Ω | 10 | 15 | 27 | μs |
| | | 50% ON to V _{OUT} Ramp Start; V _{IN} = 3.3 V, C _{LOAD} = 0.1 μF, R _{LOAD} = 10 Ω | 17 | 31 | 40 | μs |
| | | 50% ON to V _{OUT} Ramp Start; V _{IN} = 1.5 V, C _{LOAD} = 0.1 μF, R _{LOAD} = 10 Ω | 44 | 69 | 96 | μs |

An Ultra-small 1.6 mm², 28.5 mΩ, 1.0 A,
Integrated Power Switch

Electrical Characteristics (continued)

T_A = -40 °C to 85 °C unless otherwise noted. Typical values are at T_A = 25 °C

| Parameter | Description | Conditions | Min. | Typ. | Max. | Unit |
|------------------------|------------------------------|--|------|------|-----------------|------|
| T _{Total_ON} | Total Turn ON Time | 50% ON to 90% V _{OUT} ; V _{IN} = 5.0 V, C _{LOAD} = 0.1 μF, R _{LOAD} = 10 Ω | 114 | 122 | 134 | μs |
| | | 50% ON to 90% V _{OUT} ; V _{IN} = 3.3 V, C _{LOAD} = 0.1 μF, R _{LOAD} = 10 Ω | 146 | 156 | 176 | μs |
| | | 50% ON to 90% V _{OUT} ; V _{IN} = 1.5 V, C _{LOAD} = 0.1 μF, R _{LOAD} = 10 Ω | 292 | 332 | 399 | μs |
| T _{VOUT(R)} | V _{OUT} Rise Time | 10% V _{OUT} to 90% V _{OUT} ; V _{IN} = 5.0 V, C _{LOAD} = 0.1 μF, R _{LOAD} = 10 Ω | 92 | 97 | 107 | μs |
| | | 10% V _{OUT} to 90% V _{OUT} ; V _{IN} = 3.3 V, C _{LOAD} = 0.1 μF, R _{LOAD} = 10 Ω | 116 | 120 | 131 | μs |
| | | 10% V _{OUT} to 90% V _{OUT} ; V _{IN} = 1.5 V, C _{LOAD} = 0.1 μF, R _{LOAD} = 10 Ω | 228 | 253 | 296 | μs |
| ON_V _{IH} | High Input Voltage on ON pin | | 0.85 | -- | V _{IN} | V |
| ON_V _{IL} | Low Input Voltage on ON pin | | -0.3 | 0 | 0.3 | V |
| T _{OFF_Delay} | OFF Delay Time | 50% ON to V _{OUT} Fall Start, V _{IN} = 5 V, R _{LOAD} = 10 Ω, no C _{LOAD} | 6.2 | 6.5 | 7.0 | μs |

An Ultra-small 1.6 mm², 28.5 mΩ, 1.0 A, Integrated Power Switch

V_{IN} vs. Max I_{DS}, Safe Operation Area

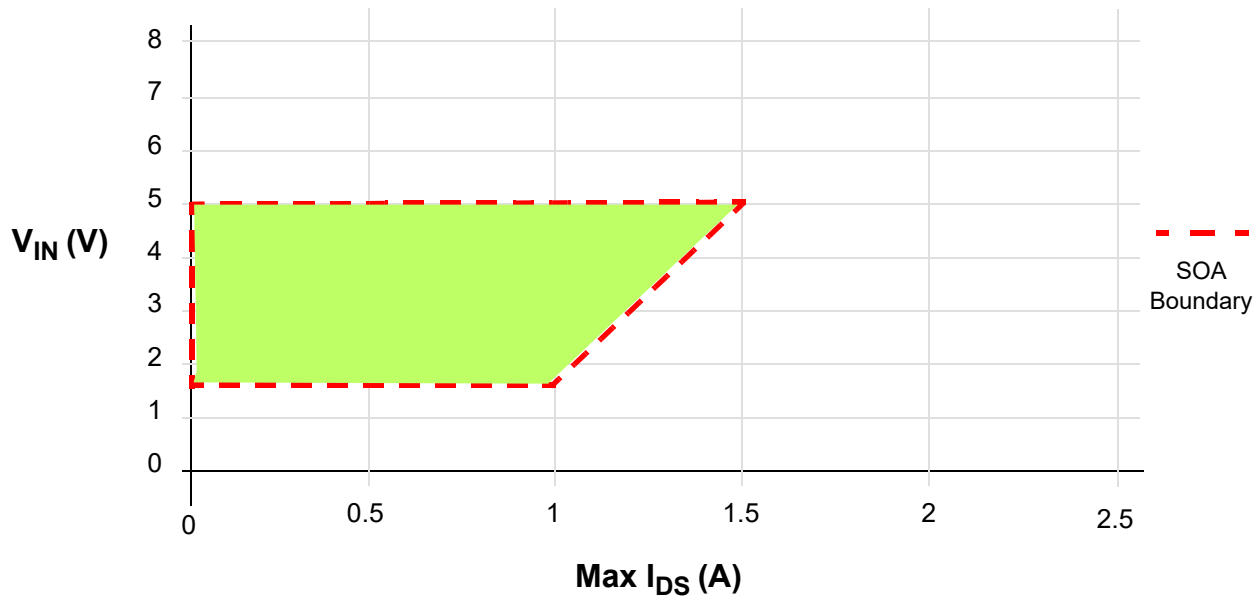

T_{Total_ON}, T_{ON_Delay} and Rise Time Measurement

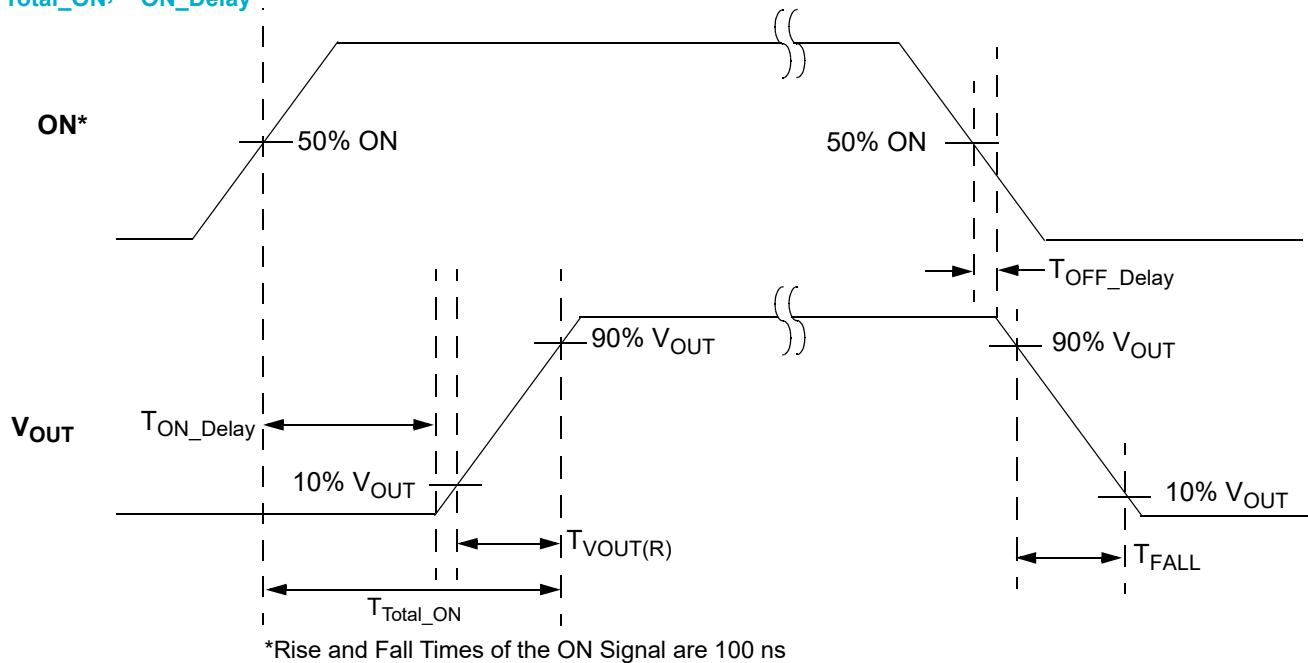

An Ultra-small 1.6 mm², 28.5 mΩ, 1.0 A,
Integrated Power Switch

SLG59M1558V Power-Up/Power-Down Sequence Considerations

A nominal power-up sequence is to apply V_{IN} and toggle the ON pin LOW-to-HIGH after V_{IN} is at least 90% of its final value. A nominal power-down sequence is the power-up sequence in reverse order. If V_{IN} ramp is too fast, a voltage glitch may appear on the output pin at VOUT. To prevent glitches at the output, it is recommended to connect at least 0.1uF capacitor from the VOUT pin to GND and to keep the V_{IN} ramp time higher than 2 ms.

Power Dissipation Considerations

The junction temperature of the SLG59M1558V depends on factors such as board layout, ambient temperature, external air flow over the package, load current, and the $R_{DS_{ON}}$ generated voltage drop across each power MOSFET. While the primary contributor to the increase in the junction temperature of the SLG59M1558V is the power dissipation of its power MOSFETs, its power dissipation and the junction temperature in nominal operating mode can be calculated using the following equations:

$$PD_{TOTAL} = R_{DS_{ON}} \times I_{DS}^2$$

where:

PD_{TOTAL} = Total package power dissipation, in Watts (W)

$R_{DS_{ON}}$ = Power MOSFET ON resistance, in Ohms (Ω)

I_{DS} = Output current, in Amps (A)

and

$$T_J = PD_{TOTAL} \times \theta_{JA} + T_A$$

where:

T_J = Die junction temperature, in Celsius degrees ($^{\circ}C$)

θ_{JA} = Package thermal resistance, in Celsius degrees per Watt ($^{\circ}C/W$) – highly dependent on pcb layout

T_A = Ambient temperature, in Celsius degrees ($^{\circ}C$)

In nominal operating mode, the SLG59M1558V's power dissipation can also be calculated by taking into account the voltage drop across the switch ($V_{IN} - V_{OUT}$) and the magnitude of the switch's output current (I_{DS}):

$$PD_{TOTAL} = (V_{IN} - V_{OUT}) \times I_{DS} \text{ or}$$

$$PD_{TOTAL} = (V_{IN} - (R_{LOAD} \times I_{DS})) \times I_{DS}$$

where:

PD_{TOTAL} = Total package power dissipation, in Watts (W)

V_{IN} = Switch input Voltage, in Volts (V)

R_{LOAD} = Output Load Resistance, in Ohms (Ω)

I_{DS} = Switch output current, in Amps (A)

V_{OUT} = Switch output voltage, or $R_{LOAD} \times I_{DS}$

SLG59M1558V

An Ultra-small 1.6 mm², 28.5 mΩ, 1.0 A, Integrated Power Switch

SLG59M1558V Layout Suggestion

 Exposed Pad (PKG face down)

 Recommended Land Pattern (PKG face down)

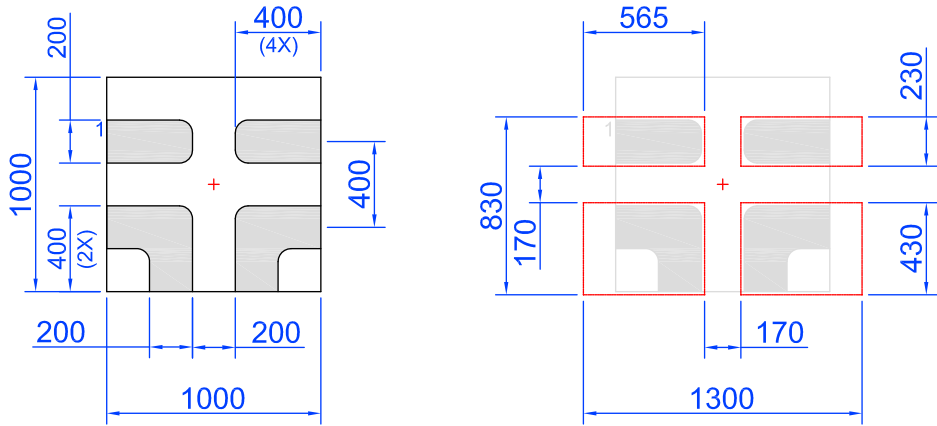

Note: All dimensions shown in micrometers (µm)

An Ultra-small 1.6 mm², 28.5 mΩ, 1.0 A, Integrated Power Switch

Layout Guidelines:

1. Since the VIN and VOUT pins dissipate most of the heat generated during high-load current operation, it is highly recommended to make power traces as short, direct, and wide as possible. A good practice is to make power traces with an absolute minimum widths of 15 mils (0.381 mm) per Ampere. A representative layout, shown in Figure 1, illustrates proper techniques for heat to transfer as efficiently as possible out of the device;
2. To minimize the effects of parasitic trace inductance on normal operation, it is recommended to connect input C_{IN} and output C_{LOAD} low-ESR capacitors as close as possible to the SLG59M1558V's VIN and VOUT pins;
3. The GND pin should be connected to system analog or power ground plane.
4. 2 oz. copper is recommended for high current operation.

SLG59M1558V Evaluation Board:

A GFET3 Evaluation Board for SLG59M1558V is designed according to the statements above and is illustrated on Figure 1. Please note that evaluation board has D_Sense and S_Sense pads. They cannot carry high currents and dedicated only for RDS_{ON} evaluation.

Please solder your SLG59M1558V here

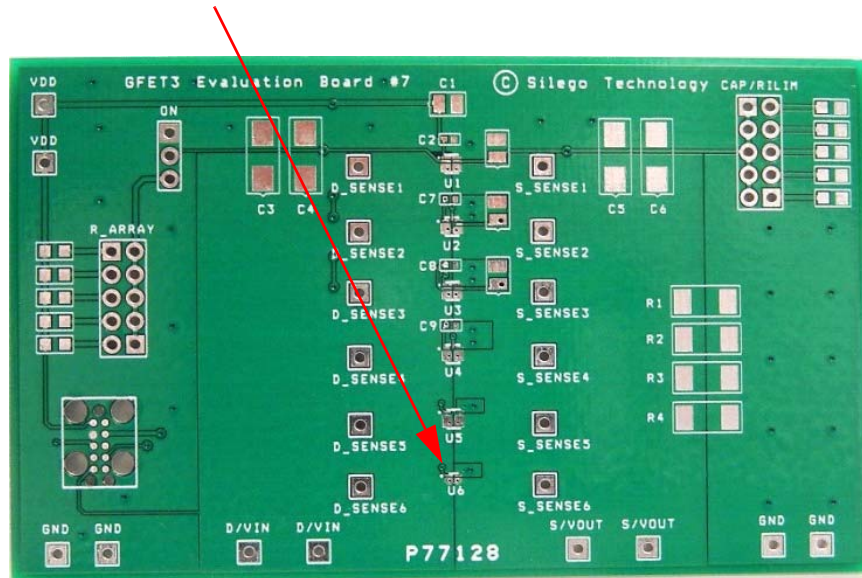

Figure 1. SLG59M1558V Evaluation Board

An Ultra-small 1.6 mm², 28.5 mΩ, 1.0 A, Integrated Power Switch

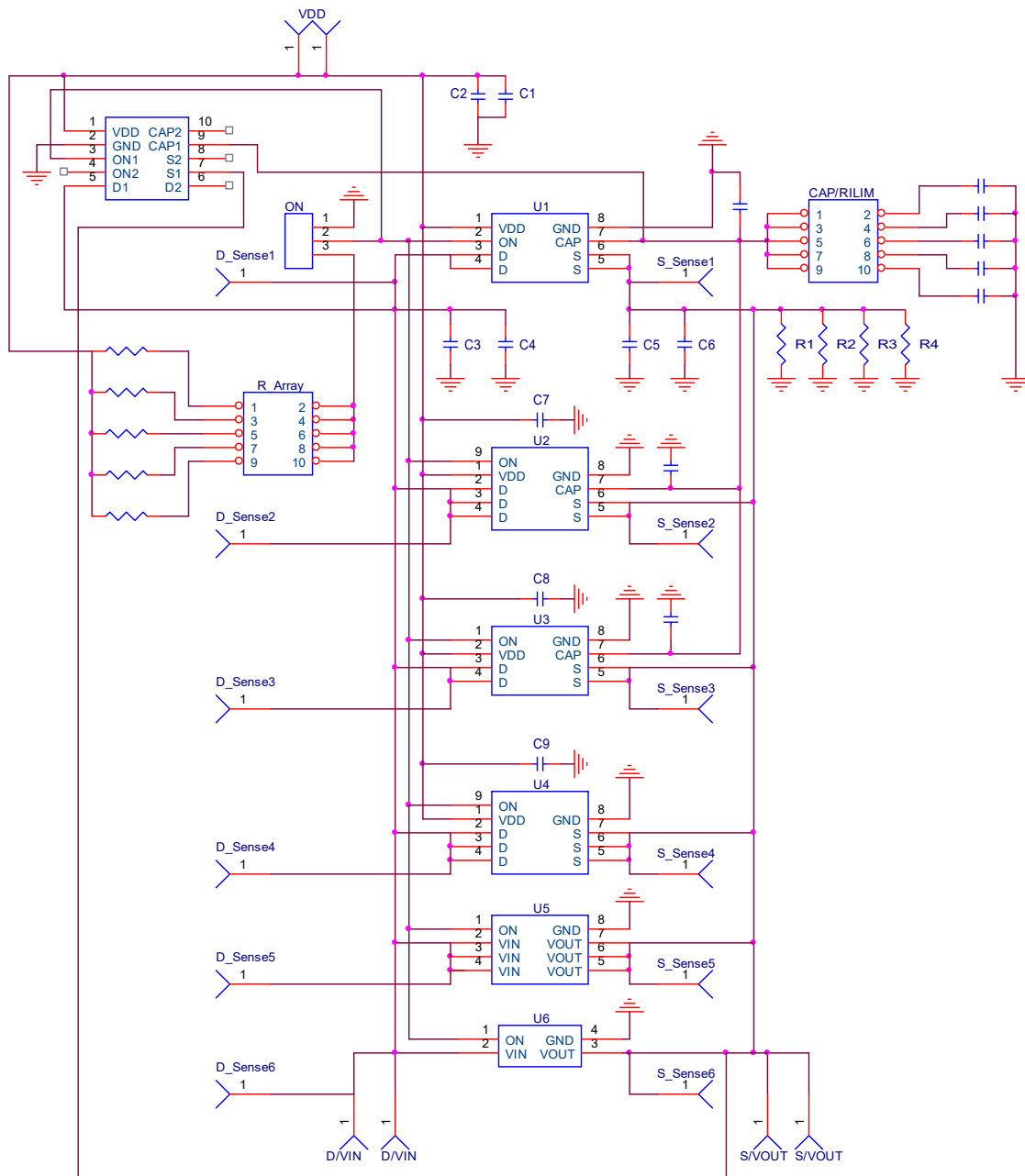

Figure 2. SLG59M1558V Evaluation Board Connection Circuit

An Ultra-small 1.6 mm², 28.5 mΩ, 1.0 A, Integrated Power Switch

Basic Test Setup and Connections

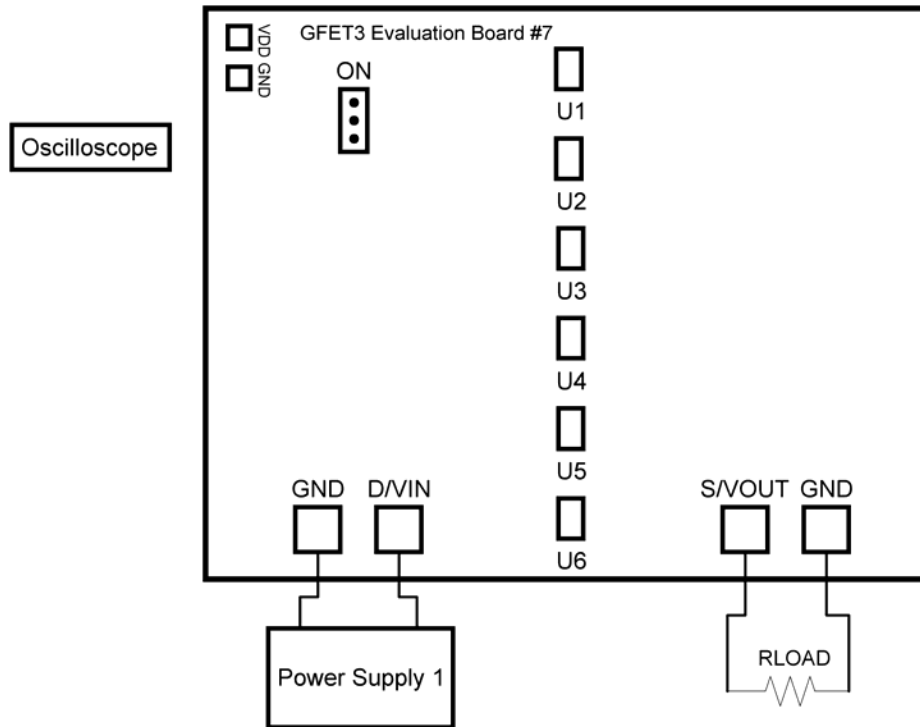

Figure 3. SLG59M1558V Evaluation Board Connection Circuit

EVB Configuration

1. Connect oscilloscope probes to D/VIN, S/VOUT, ON, etc.;
2. Turn on Power Supply 1 and set desired V_{IN} from 1.5 V...5.5 V range;
3. Toggle the ON signal High or Low to observe SLG59M1558V operation.

An Ultra-small 1.6 mm², 28.5 mΩ, 1.0 A,
Integrated Power Switch

Package Top Marking System Definition

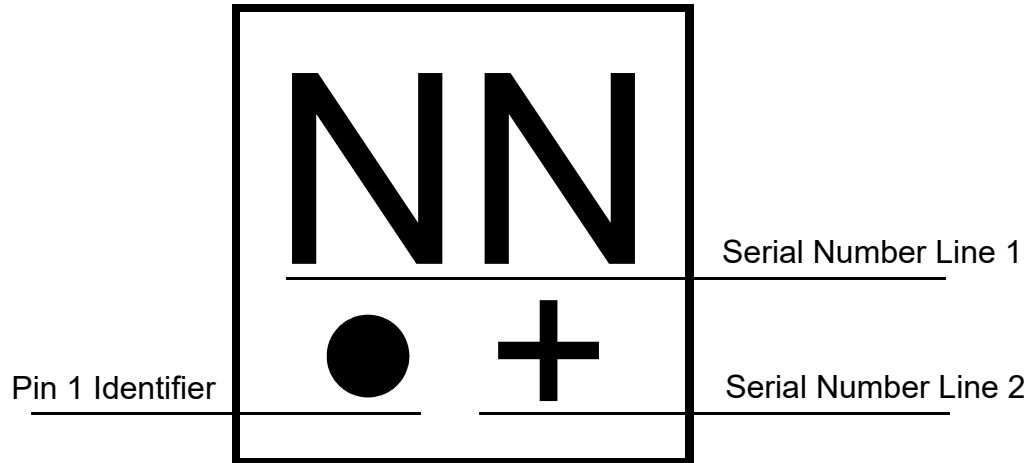

NN -Part Serial Number Field Line 1
where each "N" character can be A-Z and 0-9
+ - Part Serial Number Field Line 2
where "+" character can be +, -, =, or blank

An Ultra-small 1.6 mm², 28.5 mΩ, 1.0 A,
Integrated Power Switch

Package Drawing and Dimensions

4 Lead STDFN Package 1.0 x 1.0 mm

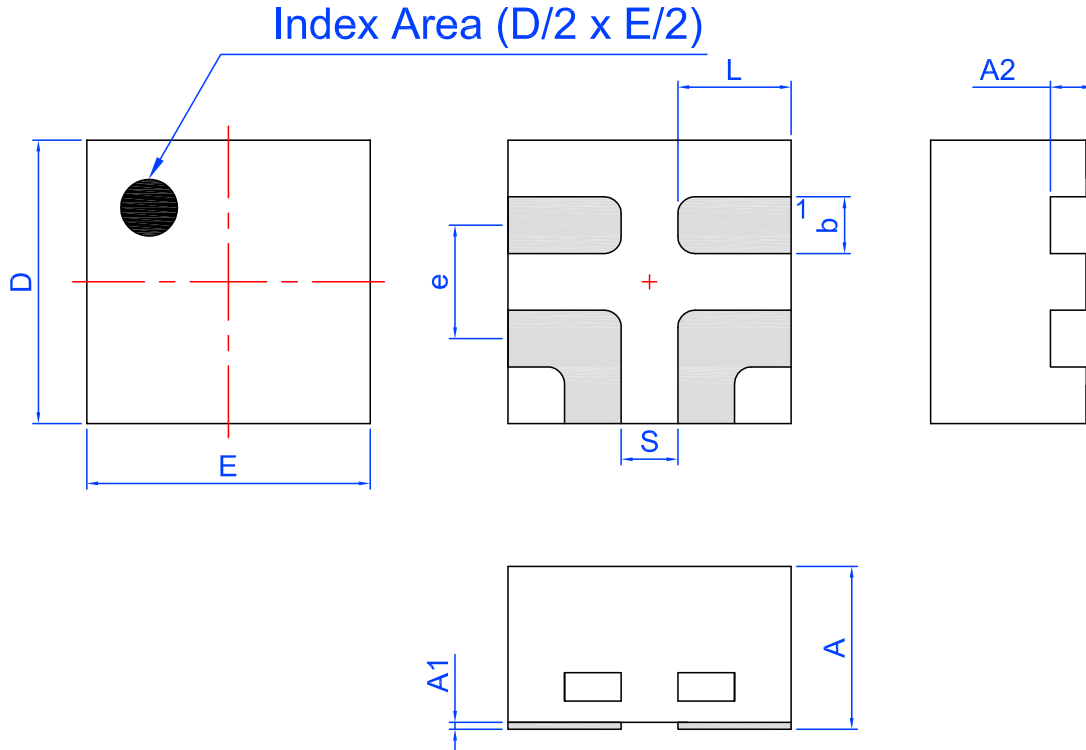

Unit: mm

| Symbol | Min | Nom. | Max | Symbol | Min | Nom. | Max |
|--------|----------|------|-------|--------|---------|------|------|
| A | 0.50 | 0.55 | 0.60 | D | 0.95 | 1.00 | 1.05 |
| A1 | 0.005 | - | 0.060 | E | 0.95 | 1.00 | 1.05 |
| A2 | 0.10 | 0.15 | 0.20 | L | 0.35 | 0.40 | 0.45 |
| b | 0.15 | 0.20 | 0.25 | S | 0.2 REF | | |
| e | 0.40 BSC | | | | | | |

An Ultra-small 1.6 mm², 28.5 mΩ, 1.0 A, Integrated Power Switch

Tape and Reel Specifications

| Package Type | # of Pins | Nominal Package Size [mm] | Max Units | | Reel & Hub Size [mm] | Leader (min) | | Trailer (min) | | Tape Width [mm] | Part Pitch [mm] |
|----------------|-----------|---------------------------|-----------|---------|----------------------|--------------|-------------|---------------|-------------|-----------------|-----------------|
| | | | per Reel | per Box | | Pockets | Length [mm] | Pockets | Length [mm] | | |
| STDFN 4L Green | 4 | 1.0 x 1.0 x 0.55 | 8000 | 8000 | 178 / 60 | 200 | 400 | 200 | 400 | 8 | 2 |

Carrier Tape Drawing and Dimensions

| Package Type | Pocket BTM Length | Pocket BTM Width | Pocket Depth | Index Hole Pitch | Pocket Pitch | Index Hole Diameter | Index Hole to Tape Edge | Index Hole to Pocket Center | Tape Width |
|----------------|-------------------|------------------|--------------|------------------|--------------|---------------------|-------------------------|-----------------------------|------------|
| | A0 | B0 | K0 | P0 | P1 | D0 | E | F | W |
| STDFN 4L Green | 1.16 | 1.16 | 0.63 | 4 | 2 | 1.5 | 1.75 | 3.5 | 8 |

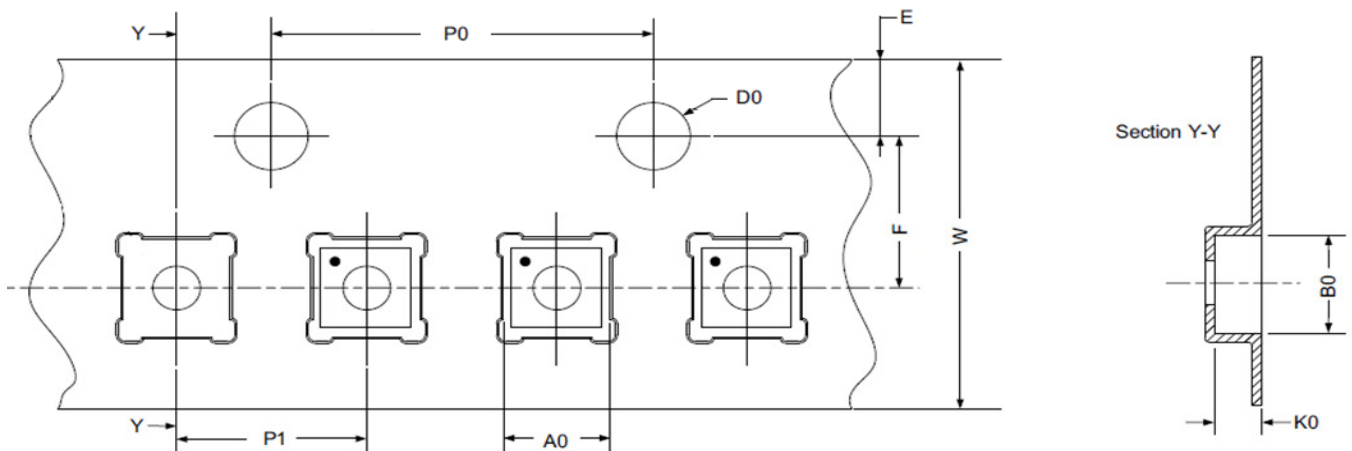

Refer to EIA-481 specification

Recommended Reflow Soldering Profile

Please see IPC/JEDEC J-STD-020: latest revision for reflow profile based on package volume of 0.55 mm³ (nominal). More information can be found at www.jedec.org.

An Ultra-small 1.6 mm², 28.5 mΩ, 1.0 A,
Integrated Power Switch

Revision History

| Date | Version | Change |
|------------|---------|---|
| 6/10/2020 | 1.05 | Updated Style and formatting Added Power Dissipation Considerations Added Layout Guidelines Fixed typos |
| 11/14/2017 | 1.04 | Updated Package Marking Definition |
| 11/30/2016 | 1.03 | Fixed Parameter name from VDD to VIN in Abs. Max Table |
| 6/22/2016 | 1.02 | Added section on Power Up/Down Sequence Considerations Removed IDS_lkg parameter (same as IDD when OFF) Updated Recommended Layout suggestion |
| 9/11/2015 | 1.01 | Updated IDD and Tdelay_ON |

Mouser Electronics

Authorized Distributor

Click to View Pricing, Inventory, Delivery & Lifecycle Information:

[Dialog Semiconductor:](#)

[SLG59M1558V](#)