

**ORDERING INFORMATION**

PART NO.	PACKING CODE	GREEN COMPOUND CODE	PACKAGE	PACKING
TS10Kxx (Note 1)	D3	Suffix "G"	TS4K	20 / TUBE
	X0		TS4K	Forming

Note 1: "xx" defines voltage from 400V (TS10K40) to 800V (TS10K80)

**EXAMPLE**

PREFERRED P/N	PART NO.	PACKING CODE	GREEN COMPOUND CODE	DESCRIPTION
TS10K80 D3	TS10K80	D3		
TS10K80 D3G	TS10K80	D3	G	Green compound

**RATINGS AND CHARACTERISTICS CURVES**

(TA=25°C unless otherwise noted)

FIG. 1 FORWARD CURRENT DERATING CURVE

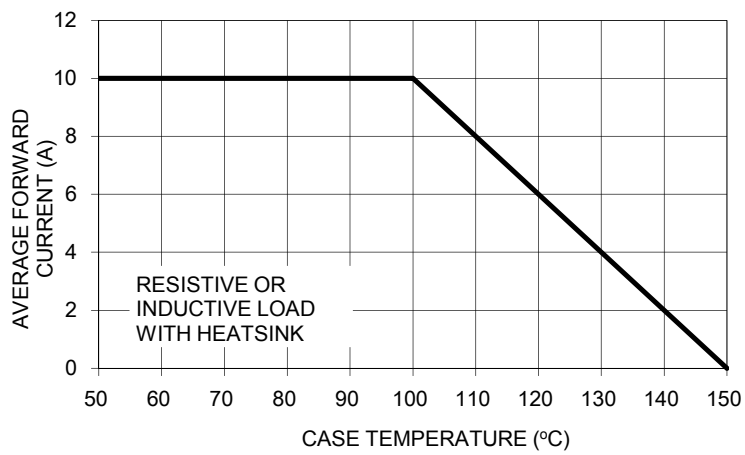

FIG. 2 TYPICAL REVERSE CHARACTERISTICS

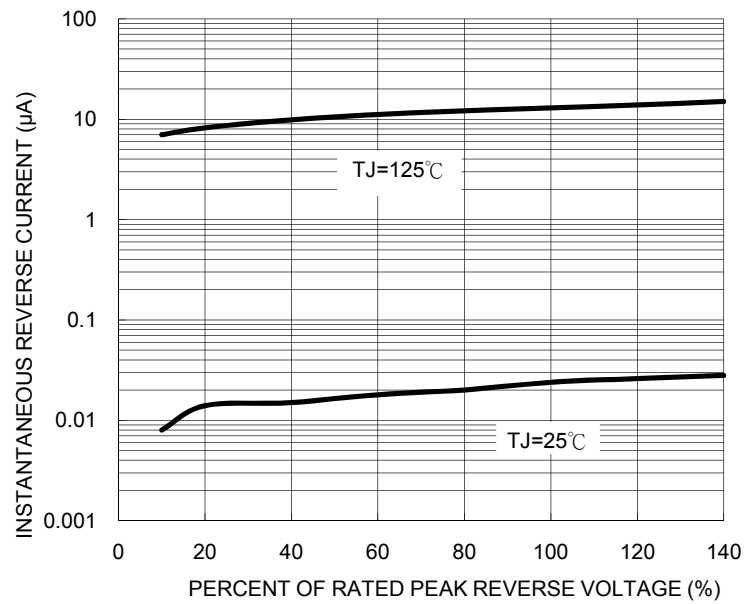

FIG. 3 MAXIMUM NON-REPETITIVE FORWARD SURGE CURRENT

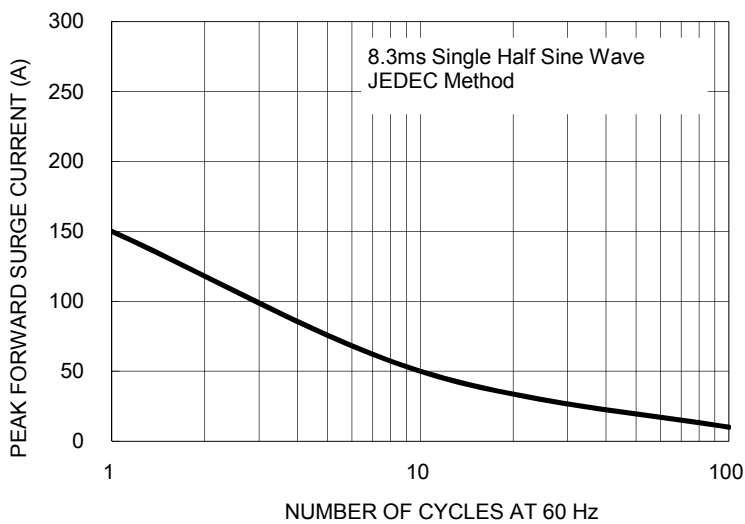

FIG. 4 TYPICAL FORWARD CHARACTERISTICS

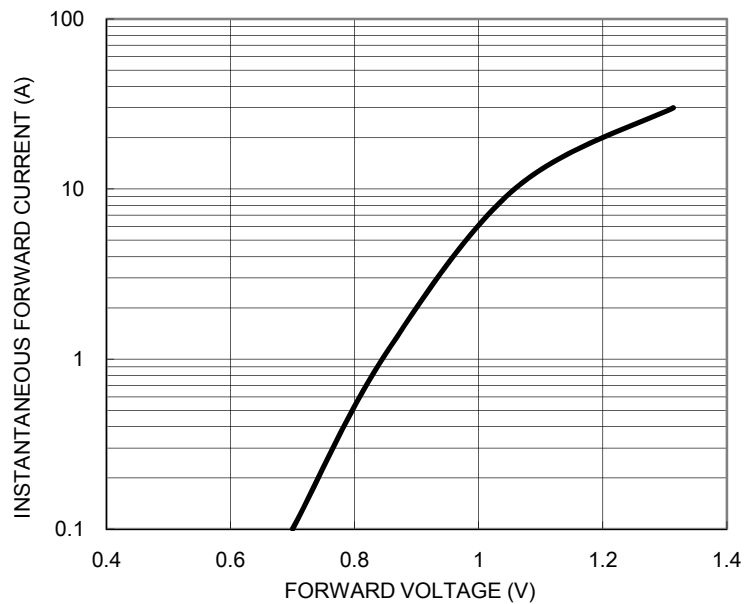
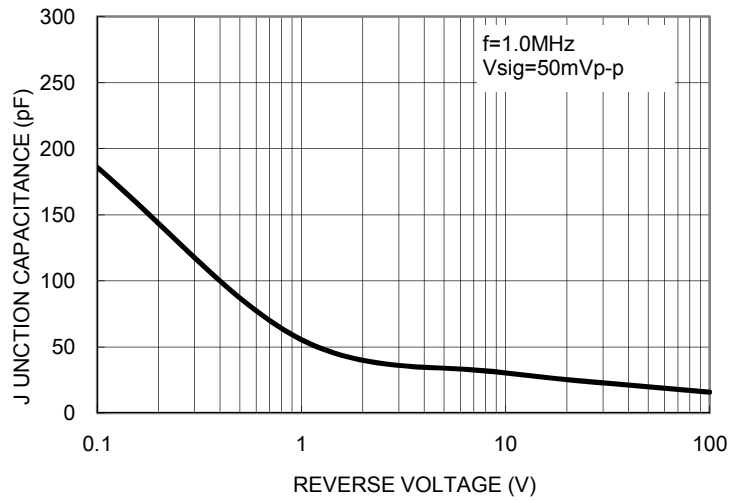
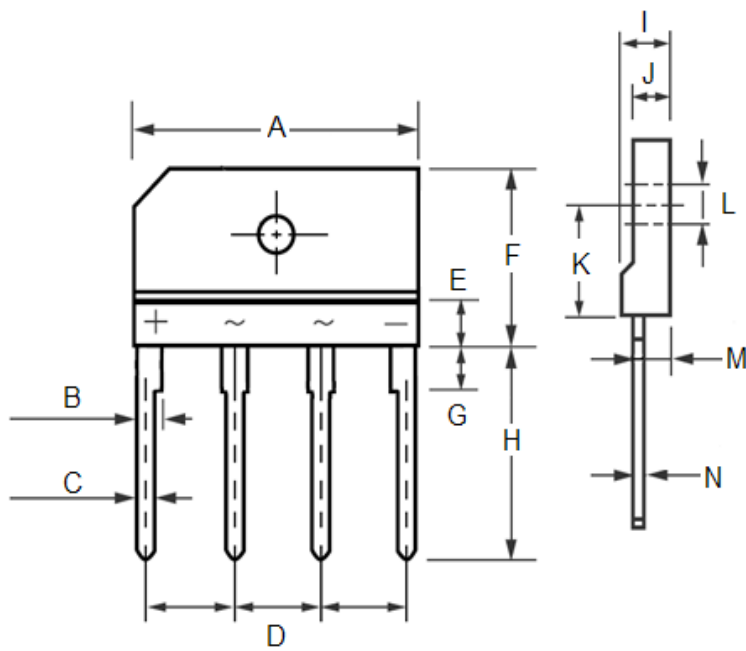

FIG. 5 TYPICAL JUNCTION CAPACITANCE



PACKAGE OUTLINE DIMENSIONS



DIM.	Unit (mm)		Unit (inch)	
	Min	Max	Min	Max
A	24.70	25.30	0.972	0.996
B	2.00	2.30	0.079	0.091
C	0.90	1.10	0.035	0.043
D	7.30	7.70	0.287	0.303
E	3.00	5.00	0.118	0.197
F	14.70	15.30	0.579	0.602
G	3.30	3.70	0.130	0.146
H	17.00	18.00	0.669	0.709
I	4.40	4.80	0.173	0.189
J	3.40	3.80	0.134	0.150
K	9.30	9.60	0.366	0.378
L	3.10	3.60	0.122	0.142
M	3.10	3.40	0.122	0.134
N	0.50	0.70	0.020	0.028

MARKING DIAGRAM



- P/N = Specific Device Code
- G = Green Compound
- YWW = Date Code
- F = Factory Code

## Notice

Specifications of the products displayed herein are subject to change without notice. TSC or anyone on its behalf, assumes no responsibility or liability for any errors inaccuracies.

Information contained herein is intended to provide a product description only. No license, express or implied, to any intellectual property rights is granted by this document. Except as provided in TSC's terms and conditions of sale for such products, TSC assumes no liability whatsoever, and disclaims any express or implied warranty, relating to sale and/or use of TSC products including liability or warranties relating to fitness for a particular purpose, merchantability, or infringement of any patent, copyright, or other intellectual property right.

The products shown herein are not designed for use in medical, life-saving, or life-sustaining applications. Customers using or selling these products for use in such applications do so at their own risk and agree to fully indemnify TSC for any damages resulting from such improper use or sale.

# Mouser Electronics

Authorized Distributor

Click to View Pricing, Inventory, Delivery & Lifecycle Information:

[Taiwan Semiconductor:](#)

[TS10K40 D3](#) [TS10K60 D3](#) [TS10K80 D3](#) [TS10K60 D3G](#)