

K-No.: 25606

Powerline transformer

Date: 26.03.2015

Customer:

Customers part no.:

Page 2 of 3

Inspection: (V: 100%-Test; AQL...: DIN ISO 2859-Teil1)

4) (Fix05) M3291: Solderability test acc. to chapter 1

5) (AQL 1/S4) M3200: Mechanical test

Type test

1) High voltage test according to M3014

 $U_{t, r.m.s.} = 7,5 \text{ kV}, \quad 1 \text{ min}, \quad N1+N2 \text{ gegen/vs } N3$

2) M3292: Resistance to soldering heat acc. to chapter 2

Measurements after temperature balance of the test samples at room temperature

Applicable documents:

Constructed, manufactured and tested in accordance to EN 60950 (IEC 950) and agrees with the standards.

Parameters: Reinforced insulation: N1+N2 to N3	and / or	Reinforced insulation: N1+N2 to N3
Working voltage: 450 V r.m.s.		Working voltage: 300 V r.m.s.
Overvoltage category: 3		Overvoltage category: 4
Pollution degree: 2		Pollution degree: 2
Insulation material group: 3		Insulation material group: 3

Housing material, casting resin and wire UL – listed

Packing: Drypack / MSL according VAC M3027

 Hrsg.: KB-E
 editor

 Bearb: Bs
 designer

 KB-PM: Ert.
 check

 freig.: HH
 released

K-No.: 25606

Powerline transformer

Date: 26.03.2015

Customer:

Customers part no.:

Page 3 of 3

packing information / Verpackungsinformation

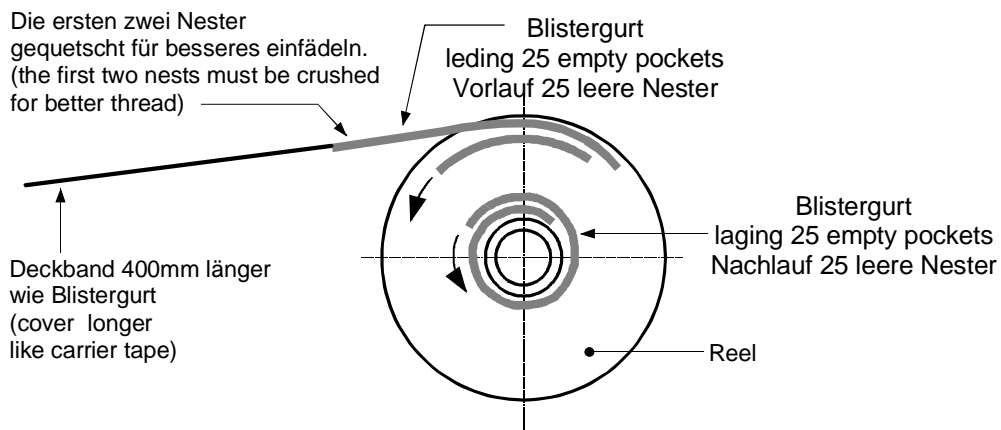
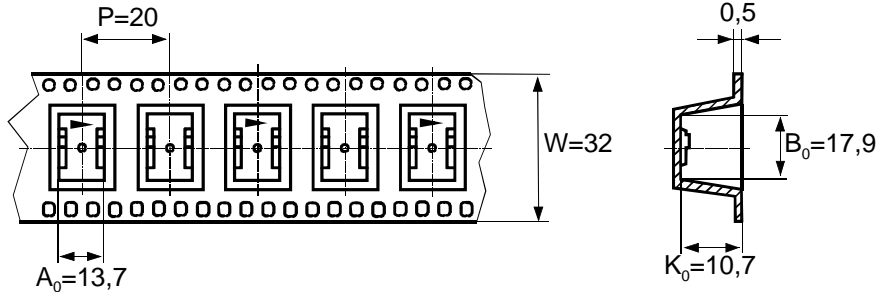

lagung: >25 empty pockets
Nachlauf >25 leere Nester

leading: >25 empty pockets
Vorlauf >25 leere Nester

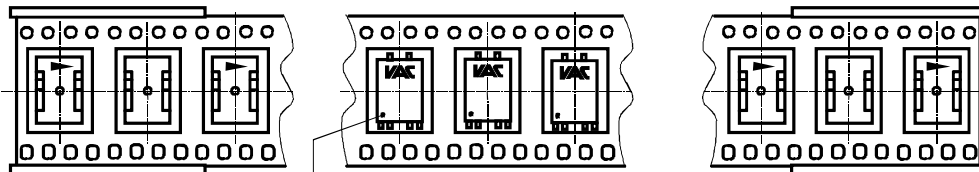

Orientierung of Pin 1 in carrier tape
Anordnung von Stift 1 im Blistergurt

Insertion of components according orientation 1 shown in M-sheet 3510
Einsetzen der Bauelemente nach M-Blatt 3510 Orientierung 1

quantities in packing: 200 pieces/tape (packing carton) 200 Bauelemente/Rolle
Verpackungsmenge 5 tapes reel/carton (outside)=1000 pieces /carton(outside)
5Rollen/Karton =1000 Bauelemente /Außenkarton

Hrsg.: KB-E
editor

Bearb: Bs
designer

KB-PM: Ert.
check

freig.: HH
released

Mouser Electronics

Authorized Distributor

Click to View Pricing, Inventory, Delivery & Lifecycle Information:

[Vacuumschmelze:](#)

[T60403-K5032-X102](#)