

DRAWING FOR REFERENCE: This is subject to change without notice
08/11/2012

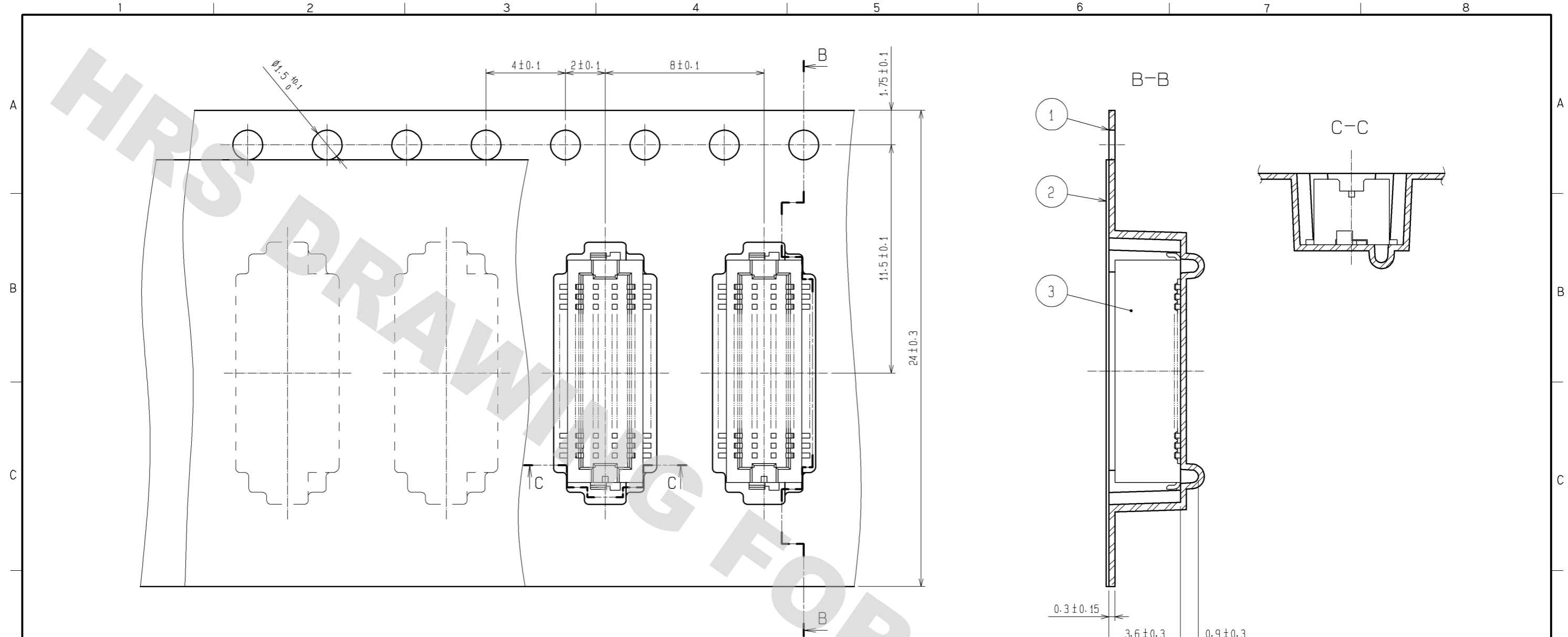

DIRECTION OF UNREELING →

STYLE AND DIMENSION OF REEL

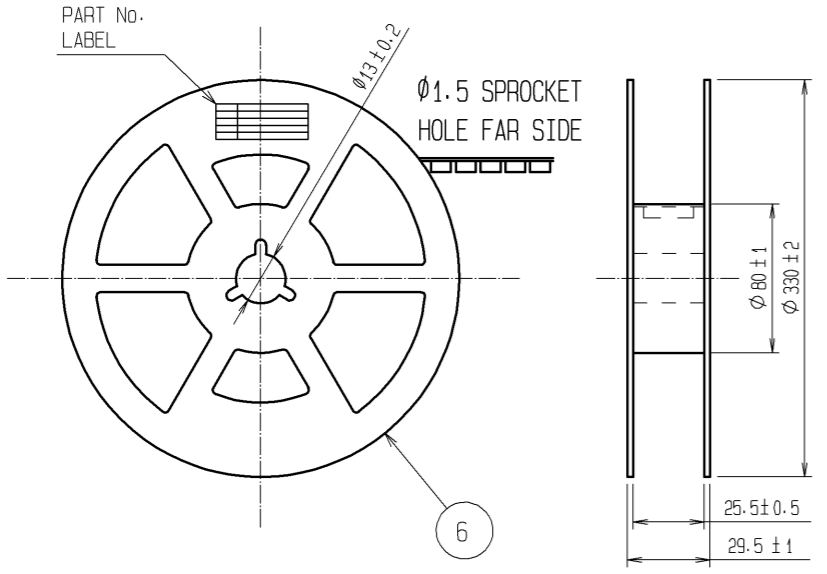

DETAIL OF PART No. LABEL

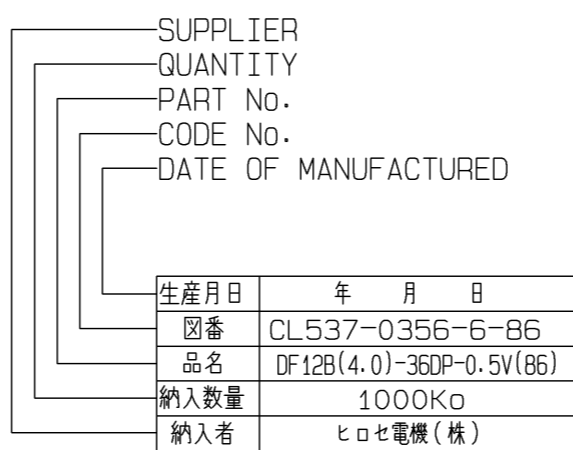

生産月日	年 月 日
図番	CL537-0356-6-86
品名	DF12B(4.0)-36DP-0.5V(86)
納入数量	1000K口
納入者	ヒロセ電機(株)

- NOTES
- 4 : 1 REEL 1000 CONNECTORS.
 - 5 : AT THE BEGINNING OF THE REEL, 30 COMPONENTS SHALL BE EMPTY.
AT THE END OF THE REEL, 20 COMPONENTS SHALL BE EMPTY.
 - 6 : PEEL FORCE REFERS TO JIS C 0806.
 - 7 : THE REEL IS PACKED WITH A POLYETHYLENE MATERIAL,
TOGETHER WITH A DRYING AGENT.

HRS	DRAWING NO.	EDC3-160533-04
	PART NO.	DF12B(4.0)-36DP-0.5V(86)
	CODE NO.	CL537-0356-6-86
		△ 2/2

Mouser Electronics

Authorized Distributor

Click to View Pricing, Inventory, Delivery & Lifecycle Information:

[Hirose Electric:](#)

[DF12B\(4.0\)-36DP-0.5V\(86\)](#)