

1.1. Ordering information

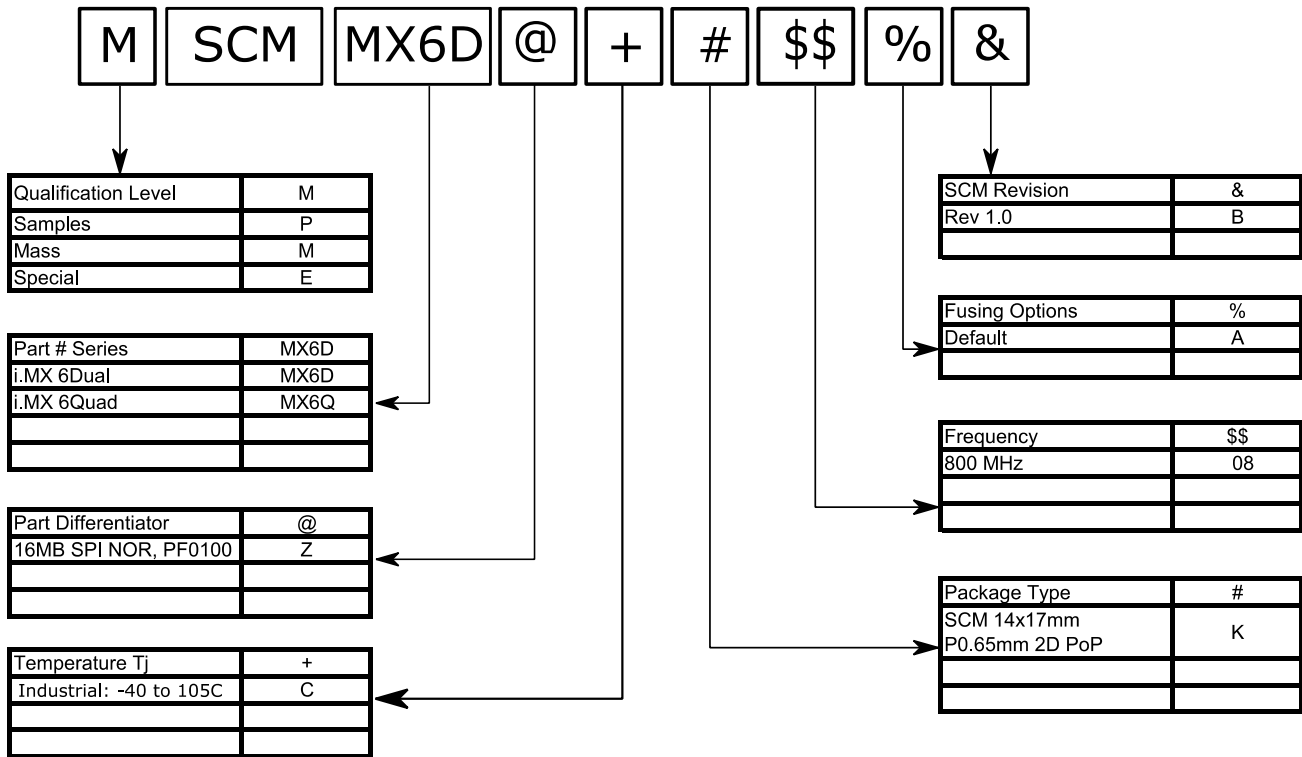

Figure 1. Part Number Nomenclature

The table below shows examples of orderable part numbers.

Table 1. Part Numbers

Part Number	CPU	Part Differentiator	Speed Grade	Temperature Grade	Package
MSCMMX6DZCK08AB	i.MX 6Dual	16MB SPI NOR, PF0100	800 MHz	Industrial: -40 to 105C	SCM 14x17mm P0.65mm 2D PoP
MSCMMX6QZCK08AB	i.MX 6Quad	16MB SPI NOR, PF0100	800 MHz	Industrial: -40 to 105C	SCM 14x17mm P0.65mm 2D PoP

1.2. Features

1.2.1. i.MX 6Dual/6Quad Features

The i.MX 6Dual/6Quad processors are based on ARM® Cortex®-A9 MPCore platform, which has the following features:

- ARM Cortex-A9 MPCore 4xCPU processor (with TrustZone®)
- The core configuration is symmetric, where each core includes:
 - 32 Kbyte L1 Instruction Cache
 - 32 Kbyte L1 Data Cache
 - Private Timer and Watchdog
 - Cortex-A9 NEON MPE (Media Processing Engine) Co-processor

The ARM Cortex-A9 MPCore complex includes:

- General Interrupt Controller (GIC) with 128 interrupt support
- Global Timer
- Snoop Control Unit (SCU)
- 1 MB unified I/D L2 cache, shared by two/four cores
- Two Master AXI (64-bit) bus interfaces output of L2 cache
- Frequency of the core (including Neon and L1 cache) as per [Table 5](#)
- NEON MPE coprocessor
 - SIMD Media Processing Architecture
 - NEON register file with 32x64-bit general-purpose registers
 - NEON Integer execute pipeline (ALU, Shift, MAC)
 - NEON dual, single-precision floating point execute pipeline (FADD, FMUL)
 - NEON load/store and permute pipeline

The SoC-level memory system consists of the following additional components:

- Boot ROM, including HAB (96 KB)
- Internal multimedia / shared, fast access RAM (OCRAM, 256 KB)
- Secure/non-secure RAM (16 KB)
- External memory interfaces:
 - 32-bit LPDDR2, supporting DDR interleaving mode, or fixed 2x32.
 - 8-bit NAND-Flash, including support for Raw MLC/SLC, 2 KB, 4 KB, and 8 KB page size, BA-NAND, PBA-NAND, LBA-NAND, OneNAND™ and others. BCH ECC up to 40 bits.

- 16/32-bit NOR Flash. All EIMv2 pins are muxed on other interfaces.
- 16/32-bit PSRAM, Cellular RAM

Each i.MX 6Dual/6Quad processor enables the following interfaces to external devices (some of them are muxed and not available simultaneously):

- Hard Disk Drives—SATA II, 3.0 Gbps
- Displays—Total of five interfaces available. Total raw pixel rate of all interfaces is up to 450 Mpixels/sec, 24 bpp. Up to four interfaces may be active in parallel.
 - One Parallel 24-bit display port, up to 225 Mpixels/sec (for example, WUXGA at 60 Hz or dual HD1080 and WXGA at 60 Hz)
 - LVDS serial ports—One port up to 165 Mpixels/sec or two ports up to 85 MP/sec (for example, WUXGA at 60 Hz) each
 - HDMI 1.4 port
 - MIPI/DSI, two lanes at 1 Gbps
- Camera sensors:
 - Parallel Camera port (up to 20 bit and up to 240 MHz peak)
 - MIPI CSI-2 serial camera port, supporting up to 1000 Mbps/lane in 1/2/3-lane mode and up to 800 Mbps/lane in 4-lane mode. The CSI-2 Receiver core can manage one clock lane and up to four data lanes. Each i.MX 6Dual/6Quad processor has four lanes.
- Expansion cards:
 - Four MMC/SD/SDIO card ports all supporting:
 - 1-bit or 4-bit transfer mode specifications for SD and SDIO cards up to UHS-I SDR-104 mode (104 MB/s max)
 - 1-bit, 4-bit, or 8-bit transfer mode specifications for MMC cards up to 52 MHz in both SDR and DDR modes (104 MB/s max)
- USB:
 - One High Speed (HS) USB 2.0 OTG (Up to 480 Mbps), with integrated HS USB PHY
 - Three USB 2.0 (480 Mbps) hosts:
 - One HS host with integrated High Speed PHY
 - Two HS hosts with integrated HS-IC USB (High Speed Inter-Chip USB) PHY
- Expansion PCI Express port (PCIe) v2.0 one lane:
 - PCI Express (Gen 2.0) dual mode complex, supporting Root complex operations and Endpoint operations. Uses x1 PHY configuration.
- Miscellaneous IPs and interfaces:
 - SSI block capable of supporting audio sample frequencies up to 192 kHz stereo inputs and outputs with I2S mode

- ESAI is capable of supporting audio sample frequencies up to 260kHz in I2S mode with 7.1 multi-channel outputs
- Five UARTs, up to 4.0 Mbps each:
 - Providing RS232 interface
 - Supporting 9-bit RS485 multidrop mode
 - One of the five UARTs (UART1) supports 8-wire while others four supports 4-wire. This is due to the SoC IOMUX limitation, since all UART IPs are identical.
- Five eCSPI (Enhanced CSPI)
- Three I2C, supporting 400 kbps
- Gigabit Ethernet Controller (IEEE1588 compliant), 10/100/1000¹ Mbps
- Four Pulse Width Modulators (PWM)
- System JTAG Controller (SJC)
- GPIO with interrupt capabilities
- 8x8 Key Pad Port (KPP)
- Sony Philips Digital Interconnect Format (SPDIF), Rx and Tx
- Two Controller Area Network (FlexCAN), 1 Mbps each
- Two Watchdog timers (WDOG)
- Audio MUX (AUDMUX)

The i.MX 6Dual/6Quad processors integrate advanced power management unit and controllers:

- Provide PMU, including LDO supplies, for on-chip resources
- Use Temperature Sensor for monitoring the die temperature
- Support DVFS techniques for low power modes
- Use Software State Retention and Power Gating for ARM and MPE
- Support various levels of system power modes
- Use flexible clock gating control scheme

The i.MX 6Dual/6Quad processors use dedicated hardware accelerators to meet the targeted multimedia performance. The use of hardware accelerators is a key factor in obtaining high performance at low power consumption numbers, while having the CPU core relatively free for performing other tasks.

¹ The theoretical maximum performance of 1 Gbps ENET is limited to 470 Mbps (total for Tx and Rx) due to internal bus throughput limitations. The actual measured performance in optimized environment is up to 400 Mbps. For details, see the ERR004512 erratum in the i.MX 6Dual/6Quad errata document [IMX6DQCE](#).

The i.MX 6Dual/6Quad processors incorporate the following hardware accelerators:

- VPU—Video Processing Unit
- IPUv3H—Image Processing Unit version 3H (2 IPU)
- GPU3Dv4—3D Graphics Processing Unit (OpenGL ES 2.0) version 4
- GPU2Dv2—2D Graphics Processing Unit (BitBlit)
- GPUVG—OpenVG 1.1 Graphics Processing Unit
- ASRC—Asynchronous Sample Rate Converter

Security functions are enabled and accelerated by the following hardware:

- ARM TrustZone including the TZ architecture (separation of interrupts, memory mapping, etc.)
- SJC—System JTAG Controller. Protecting JTAG from debug port attacks by regulating or blocking the access to the system debug features.
- CAAM—Cryptographic Acceleration and Assurance Module, containing 16 KB secure RAM and True and Pseudo Random Number Generator (NIST certified)
- SNVS—Secure Non-Volatile Storage, including Secure Real Time Clock
- CSU—Central Security Unit. Enhancement for the IC Identification Module (IIM). Will be configured during boot and by eFUSES and will determine the security level operation mode as well as the TZ policy.
- A-HAB—Advanced High Assurance Boot—HABv4 with the new embedded enhancements: SHA-256, 2048-bit RSA key, version control mechanism, warm boot, CSU, and TZ initialization.

1.2.2. PF0100Z Features

- Input voltage range to PMIC: 2.8 - 4.5 V
- Buck regulators
 - Four to six channel configurable
 - SW1A/B/C, 4.5 A (single); 0.3 to 1.875 V
 - SW1A/B, 2.5 A (single/dual); SW1C 2.0 A (independent); 0.3 to 1.875 V
 - SW2, 2.0 A; 0.4 to 3.3 V
 - SW3A/B, 2.5 A (single/dual); 0.4 to 3.3 V
 - SW3A, 1.25 A (independent); SW3B, 1.25 A (independent); 0.4 to 3.3 V
 - SW4, 1.0 A; 0.4 to 3.3 V
 - SW4, VTT mode provide DDR termination at 50% of SW3A
 - Dynamic voltage scaling
 - Modes: PWM, PFM, APS

- Programmable output voltage
- Programmable current limit
- Programmable soft start
- Programmable PWM switching frequency
- Programmable OCP with fault interrupt
- Boost regulator
 - SWBST, 5.0 to 5.15 V, 0.6 A, OTG support
 - Modes: PFM and Auto
 - OCP fault interrupt
- LDOs
 - Six user programmable LDO
 - VGEN1, 0.80 to 1.55 V, 100 mA
 - VGEN2, 0.80 to 1.55 V, 250 mA
 - VGEN3, 1.8 to 3.3 V, 100 mA
 - VGEN4, 1.8 to 3.3 V, 350 mA
 - VGEN5, 1.8 to 3.3 V, 100 mA

NOTE

VGEN5 power characteristics are modified from what is displayed in Table 106 of the MMPF0100 datasheet. SCM-specific tolerances are $\pm 5\%$, rather than $\pm 3\%$ as presented in the table.

- VGEN6, 1.8 to 3.3 V, 200 mA
- Soft start
- LDO/Switch supply
 - VSNVS (1.0/1.1/1.2/1.3/1.5/1.8/3.0 V), 400uA
- DDR memory reference voltage
 - VREFDDR, 0.6 to 0.9 V, 10 mA
- 16 MHz internal master clock
- OTP(One time programmable) memory for device configuration
 - User programmable start-up sequence and timing
- Battery backed memory including coin cell charger
- I2C interface
- User programmable Standby, Sleep, and Off modes

1.3. References

This document is intended to be a companion to the data sheets of the following integrated parts:

- a) NXP i.MX 6Dual/6Quad (Document Number: [IMX6DQIEC](#))
- b) NXP MMPF0100 (Document Number: [MMPF0100Z](#))
- c) SPI NOR ([N25Q128A13](#))

2. Architectural Overview

The following subsection provides an architectural overview of the SCM-i.MX 6Dual/6Quad.

2.1. Block Diagram

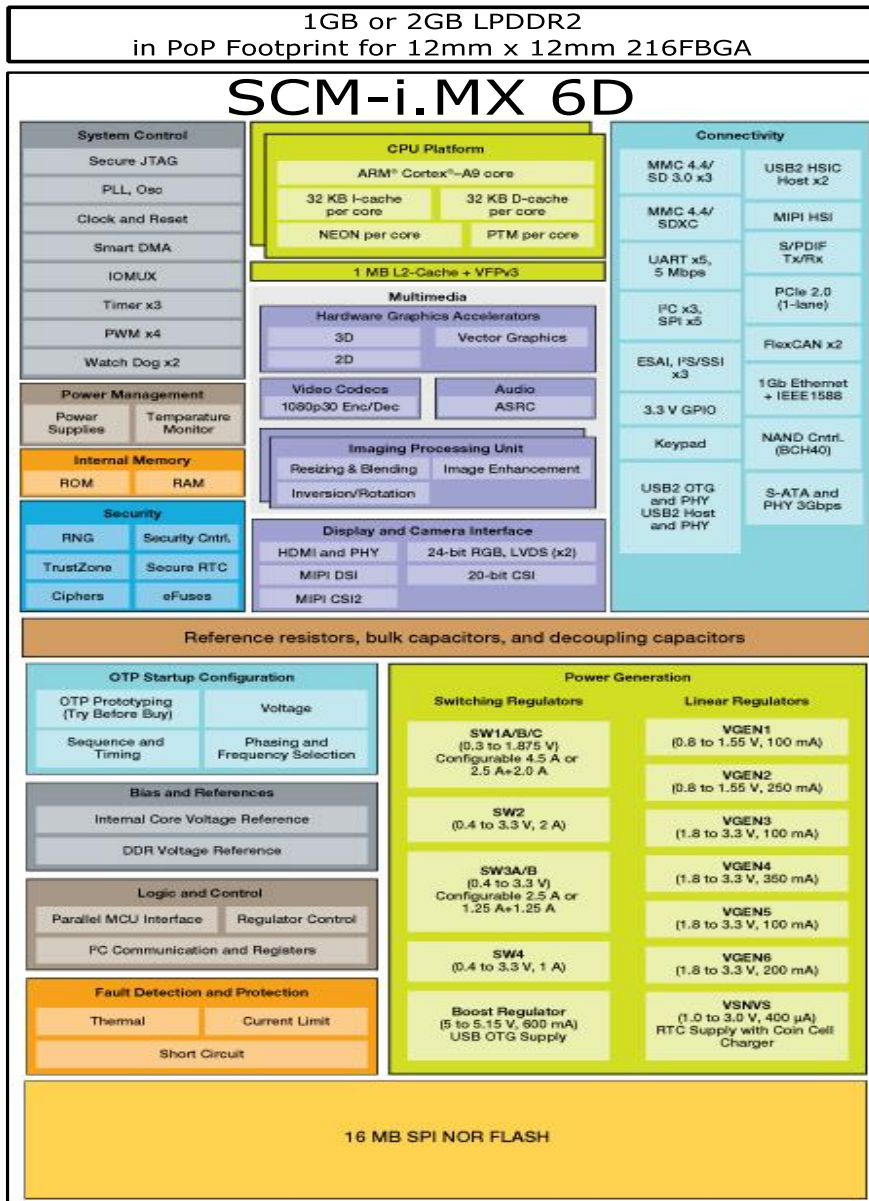

Figure 2. SCM-i.MX 6Dual/6Quad Block Diagram

3. Modules List

Table 2. Modules List

Block Name	Description/Notes
i.MX 6Dual/6Quad	NXP i.MX 6Dual/6Quad Applications Processor. Fully functional as a normal i.MX 6Dual/6Quad except the MLB bus is disabled and not pinned out.
MMPF0100	Power management IC requires only a single supply and can provide power and voltage references to entire SCM. Refer to section 4 for electrical details.
SPI NOR	16 megabytes of SPI NOR which is fully available for user programming.
LPDDR2 PoP Interface	Interface to support LPDDR2 in PoP configuration using a 12mm x 12mm FBGA216 footprint.
Discrete Components	109 passives for decoupling capacitors and reference resistors.

3.1. Special Signal Considerations

The figure below shows critical internal connections, pull-ups and pulldowns.

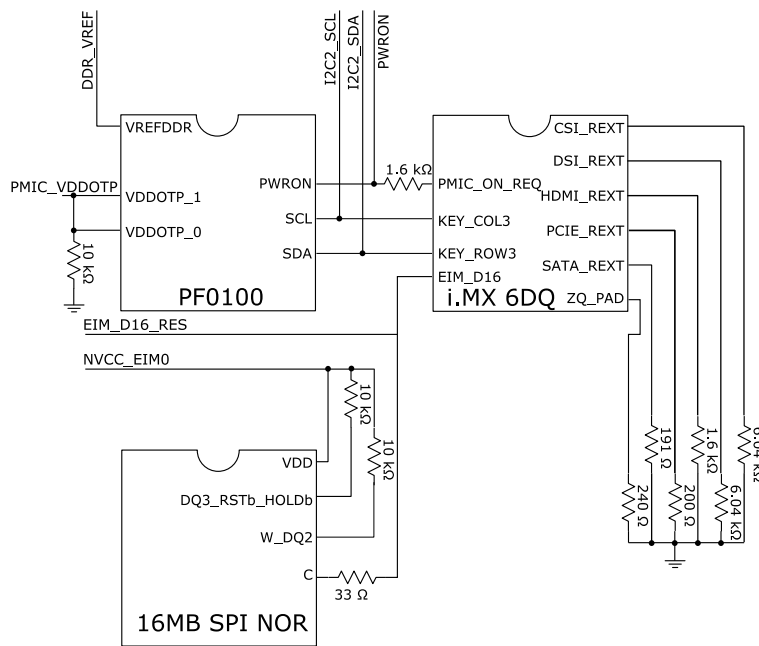

Figure 3. SCM-i.MX 6Dual/6Quad Critical Internal Connections

Note

DDR_VREF is connected internally to the LPDDR2 memory through one of the PoP landing pads.

4. Electrical Characteristics

4.1. Chip-Level Conditions

4.1.1. Absolute Max Ratings

CAUTION

Stresses beyond those listed under Table 3, 4 and 5 may affect reliability or cause permanent damage to the device. These are stress ratings only. Functional operation of the device at these or any other conditions beyond those indicated in the Operating Ranges or Parameters tables is not implied."

Table 3. Absolute Max Ratings

Parameter Description	Symbol	Min	Max	Unit
PMIC System Supply Voltage Range	PMIC_VIN	-0.3	4.8	V
Temperature range (storage)	T_storage	-40	150	C

4.1.2. Thermal Resistance

Table 4 provides the FO-WLP thermal resistance data.

Table 4. FO-WLP Thermal Resistance Data

Parameter Description	Test Condition	Symbol	Value	Unit
Junction to Ambient ^{1,6}	Single-layer board (1s); natural convection ²	R _{θJA}	36.5	°C/W
	Four-layer board (2s2p); natural convection ²	R _{θJA}	19.9	°C/W
Junction to Ambient ^{1,6}	Single-layer board (1s); air flow 200ft/min ³	R _{θJMA}	27.7	°C/W
	Four-layer board (2s2p); air flow 200ft/min ³	R _{θJMA}	16.1	°C/W
Junction to Board ^{1,4,6}	-	R _{θJB}	6.6	°C/W
Junction to top characterization parameter ^{1,5,6}	-	Ψ _{JT}	2.9	°C/W

¹ Junction temperature is a function of die size, on-chip power dissipation, package thermal resistance, mounting site (board) temperature, ambient temperature, air flow, power dissipation of other components on the board, and board thermal resistance.

² Per SEMI G38-87 and JEDEC JESD51-2 with the single layer board horizontal.

³ Per JEDEC JESD51-6 with the board horizontal.

⁴ Thermal resistance between the die and the printed circuit board per JEDEC JESD51-8. Board temperature is measured on the top surface of the board near the package.

⁵ Thermal characterization parameter indicating the temperature difference between package top and the junction temperature per JEDEC JESD51-2. When Greek letters are not available, the thermal characterization parameter is written as Psi-JT.

⁶ Values reported are modeled and based upon a summation of power dissipation of multiple die within the package. Junction temperatures will vary between die according to power ratios and use case.

4.1.3. Operating Ranges

Table 5. Operating Ranges

Parameter Description	Symbol	Min	Max	Unit
PMIC System Supply Voltage Range	PMIC_VIN	3.6	4.5	V
SPI NOR Flash Supply Voltage Range	NVCC_EIM0_NOR	2.775	3.6	V
Junction Temperature (standard industrial)	Tj	-40	105	C

5. Power Supplies Requirements and Restrictions

SCM-specific power-up sequence requirements are shown in SCM-IMX6DQHUG.

5.1. Power-Up Sequences

Must follow the i.MX 6Dual/6Quad industrial datasheet (Document Number: [IMX6DQIEC](#)) recommendations for power up. The internal PMIC simplifies power sequence design.

5.2. Power-Down Sequences

Must follow the i.MX 6Dual/6Quad industrial datasheet (Document Number: [IMX6DQIEC](#)) recommendations for power down.

5.3. Power Supplies Usage

Must follow the i.MX 6Dual/6Quad industrial datasheet (Document Number: [IMX6DQIEC](#)) recommendations for power supply usage.

5.4. Power Supplies Restrictions

DDR_1V2 and DDR_1V2_SW3AFB (switcher 3 feedback pin) are internally connected for dedicated LPDDR2 usage with SW3. SW3 cannot be used to supply anything else but the LPDDR2.

5.5. Boot Configuration

5.5.1. OTP PMIC

Table 6. OTP Fuse Map

Registers	Default Configuration	Pre-programmed OTP Configuration	Program code (hex)	Intended Use
SW1AB_VOLT	1.375V	1.375V	2B	VDDSOC
SW1AB_SEQ	1	2	02	
SW1AB CONFIG	Single Phase, 2.0 MHz	Single Phase, 2.0 MHz	05	

Registers	Default Configuration	Pre-programmed OTP Configuration	Program code (hex)	Intended Use
SW1C_VOLT	1.375	1.375V	00	VDDARM
SW1C_SEQ	1	2	02	
SW1C CONFIG	Independent, 2.0 MHz	Independent, 2.0 MHz	00	
SW2_VOLT	3.0V	3.15V	6F	VDDHIGH_IN
SW2_SEQ	2	1	01	
SW2 CONFIG	Single Phase, 2.0 MHz	Single Phase, 2.0 MHz	01	
SW3A_VOLT	1.5V	1.2V	20	DDR 1.2V
SW3A_SEQ	3	4	04	
SW3A CONFIG	Single Phase, 2.0 MHz	Single Phase, 2.0 MHz	05	
SW3B_VOLT	1.5V	1.2V	20	DDR 1.2V
SW3B_SEQ	3	4	04	
SW3B CONFIG	Single Phase, 2.0 MHz	Single Phase, 2.0 MHz	01	
SW4_VOLT	1.8V	1.8V	54	DDR 1.8V
SW4_SEQ	3	4	04	
SW4_CONFIG	No VTT, 2.0MHz	No VTT, 2.0 MHz	01	
SWBST_VOLT	-	-	00	Customer
SWBST_SEQ	-	4	04	
VSNVS_VOLT	3.0V	3.0V	06	VDD_SNVS_IN
VREFDDR_SEQ	3	4	04	
VGEN1_VOLT	-	-	00	Customer
VGEN1_SEQ	-	-	00	
VGEN2_VOLT	1.5V	-	00	Customer
VGEN2_SEQ	2	-	00	
VGEN3_VOLT	-	-	00	Customer
VGEN3_SEQ	-	-	00	
VGEN4_VOLT	1.8V	-	00	Customer
VGEN4_SEQ	3	-	00	
VGEN5_VOLT	2.5V	-	00	Customer
VGEN5_SEQ	3	-	00	
VGEN6_VOLT	2.8V	-	00	Customer
VGEN6_SEQ	3	-	00	
PU CONFIG1, SEQ_CLK_SPEED	1.0ms	1.0ms	01	
PU CONFIG2, SWDVS_CLK	6.25 mV/us	12.5mV/us	00	
PU CONFIG3, PWRON	Level sensitive	Level sensitive	00	
PG EN	RESETBMCU in Default Mode	00		

Note

1. Refer to application notes AN4714 (Features of Voltage Regulators in the MMPF0100) and AN4536 (MMPF0100 OTP Programming Instructions) for further usage instructions.
2. The OTP registers for regulators which default to (OFF) are free to be programmed according to customer needs.
3. The OTP Lock bit is not programmed from factory.
4. NXP not responsible for device issues caused by customer fuse programming.

6. Boot Mode Configuration

6.1. Boot Mode Configuration Pins

Refer to the i.MX 6Dual/6Quad industrial datasheet (Document Number: [IMX6DQIEC](#)).

6.2. Boot Devices Interfaces Allocation

Not limited to booting from internal SPI NOR.

Refer to the i.MX 6Dual/6Quad industrial datasheet (Document Number: [IMX6DQIEC](#)).

7. Package Information

7.1. Signal List

Table 7. Signal List

Ball Name	Ball	Power Group	Comments
BOOT_MODE0	U11	VDD_SNV5_IN	
BOOT_MODE1	V12	VDD_SNV5_IN	
CLK1_N	U18	VDD_HIGH_CAP	
CLK1_P	U17	VDD_HIGH_CAP	
CLK2_N	W19	VDD_HIGH_CAP	
CLK2_P	W20	VDD_HIGH_CAP	
CSI_CLK0M	N20	NVCC_MIPI	
CSI_CLK0P	N19	NVCC_MIPI	
CSI_D0M	R20	NVCC_MIPI	
CSI_D0P	R19	NVCC_MIPI	
CSI_D1M	P19	NVCC_MIPI	
CSI_D1P	P20	NVCC_MIPI	
CSI_D2M	M19	NVCC_MIPI	
CSI_D2P	M20	NVCC_MIPI	

Ball Name	Ball	Power Group	Comments
CSI_D3M	L20	NVCC_MIPI	
CSI_D3P	L19	NVCC_MIPI	
CSIO_DAT10	H17	NVCC_CSI	
CSIO_DAT11	H18	NVCC_CSI	
CSIO_DAT12	J17	NVCC_CSI	
CSIO_DAT13	J18	NVCC_CSI	
CSIO_DAT14	K17	NVCC_CSI	
CSIO_DAT15	K16	NVCC_CSI	
CSIO_DAT16	N16	NVCC_CSI	
CSIO_DAT17	M18	NVCC_CSI	
CSIO_DAT18	L17	NVCC_CSI	
CSIO_DAT19	M17	NVCC_CSI	
CSIO_DAT4	E17	NVCC_CSI	
CSIO_DAT5	E18	NVCC_CSI	
CSIO_DAT6	F17	NVCC_CSI	
CSIO_DAT7	F18	NVCC_CSI	
CSIO_DAT8	G17	NVCC_CSI	
CSIO_DAT9	G18	NVCC_CSI	
CSIO_DATA_EN	D18	NVCC_CSI	
CSIO_MCLK	C18	NVCC_CSI	
CSIO_PIXCLK	C17	NVCC_CSI	
CSIO_VSYNC	D17	NVCC_CSI	
DIO_DISP_CLK	A4	NVCC_LCD	
DIO_PIN15	A2	NVCC_LCD	
DIO_PIN2	B4	NVCC_LCD	
DIO_PIN3	B3	NVCC_LCD	
DIO_PIN4	A3	NVCC_LCD	
DISPO_DAT0	D5	NVCC_LCD	
DISPO_DAT1	C5	NVCC_LCD	
DISPO_DAT10	B7	NVCC_LCD	
DISPO_DAT11	A7	NVCC_LCD	
DISPO_DAT12	D8	NVCC_LCD	
DISPO_DAT13	C8	NVCC_LCD	
DISPO_DAT14	B8	NVCC_LCD	
DISPO_DAT15	A8	NVCC_LCD	
DISPO_DAT16	D9	NVCC_LCD	
DISPO_DAT17	C9	NVCC_LCD	
DISPO_DAT18	B9	NVCC_LCD	
DISPO_DAT19	A9	NVCC_LCD	
DISPO_DAT2	B5	NVCC_LCD	

Ball Name	Ball	Power Group	Comments
DISPO_DAT20	D10	NVCC_LCD	
DISPO_DAT21	C10	NVCC_LCD	
DISPO_DAT22	B10	NVCC_LCD	
DISPO_DAT23	A10	NVCC_LCD	
DISPO_DAT3	A5	NVCC_LCD	
DISPO_DAT4	D6	NVCC_LCD	
DISPO_DAT5	C6	NVCC_LCD	
DISPO_DAT6	B6	NVCC_LCD	
DISPO_DAT7	A6	NVCC_LCD	
DISPO_DAT8	D7	NVCC_LCD	
DISPO_DAT9	C7	NVCC_LCD	
DSI_CLK0M	P18	NVCC_MIPI	
DSI_CLK0P	P17	NVCC_MIPI	
DSI_D0M	R17	NVCC_MIPI	
DSI_D0P	R18	NVCC_MIPI	
DSI_D1M	N17	NVCC_MIPI	
DSI_D1P	N18	NVCC_MIPI	
EIM_A16	H1	NVCC_EIM1	
EIM_A17	H4	NVCC_EIM1	
EIM_A18	J2	NVCC_EIM1	
EIM_A19	J3	NVCC_EIM1	
EIM_A20	J4	NVCC_EIM1	
EIM_A21	K1	NVCC_EIM1	
EIM_A22	K2	NVCC_EIM1	
EIM_A23	K3	NVCC_EIM1	
EIM_A24	K4	NVCC_EIM1	
EIM_A25	R5	NVCC_EIM0	
EIM_BCLK	B1	NVCC_EIM2	
EIM_CS0	H3	NVCC_EIM1	
EIM_CS1	H2	NVCC_EIM1	
EIM_D16_NOR	V3	NVCC_EIM0_NOR	
EIM_D17_NOR	U4	NVCC_EIM0_NOR	
EIM_D18_NOR	U3	NVCC_EIM0_NOR	
EIM_D19	T4	NVCC_EIM0_NOR	
EIM_D20	T3	NVCC_EIM0_NOR	
EIM_D21	R4	NVCC_EIM0_NOR	
EIM_D22	P3	NVCC_EIM0_NOR	
EIM_D23	P4	NVCC_EIM0_NOR	
EIM_D24	T5	NVCC_EIM0_NOR	
EIM_D25	N3	NVCC_EIM0_NOR	

Ball Name	Ball	Power Group	Comments
EIM_D26	M4	NVCC_EIM0_NOR	
EIM_D27	M3	NVCC_EIM0_NOR	
EIM_D28	L4	NVCC_EIM0_NOR	
EIM_D29	L3	NVCC_EIM0_NOR	
EIM_D30	L2	NVCC_EIM0_NOR	
EIM_D31	L1	NVCC_EIM0_NOR	
EIM_DA0	E1	NVCC_EIM2	
EIM_DA1	F4	NVCC_EIM2	
EIM_DA10	D2	NVCC_EIM2	
EIM_DA11	D4	NVCC_EIM2	
EIM_DA12	C4	NVCC_EIM2	
EIM_DA13	B2	NVCC_EIM2	
EIM_DA14	C2	NVCC_EIM2	
EIM_DA15	C3	NVCC_EIM2	
EIM_DA2	F2	NVCC_EIM2	
EIM_DA3	F3	NVCC_EIM2	
EIM_DA4	E2	NVCC_EIM2	
EIM_DA5	D1	NVCC_EIM2	
EIM_DA6	E4	NVCC_EIM2	
EIM_DA7	E3	NVCC_EIM2	
EIM_DA8	C1	NVCC_EIM2	
EIM_DA9	D3	NVCC_EIM2	
EIM_EB0	G3	NVCC_EIM2	
EIM_EB1	G2	NVCC_EIM2	
EIM_EB2_NOR	V4	NVCC_EIM0_NOR	
EIM_EB3	N4	NVCC_EIM0_NOR	
EIM_LBA	F1	NVCC_EIM1	
EIM_OE	G1	NVCC_EIM1	
EIM_RW	G4	NVCC_EIM1	
EIM_WAIT	F5	NVCC_EIM2	
ENET_CRS_DV	D11	NVCC_ENET	
ENET_MDC	D12	NVCC_ENET	
ENET_MDIO	C12	NVCC_ENET	
ENET_REF_CLK	C13	NVCC_ENET	
ENET_RX_ER	C11	NVCC_ENET	
ENET_RXD0	A11	NVCC_ENET	
ENET_RXD1	B11	NVCC_ENET	
ENET_TX_EN	D13	NVCC_ENET	
ENET_TXD0	A12	NVCC_ENET	
ENET_TXD1	B12	NVCC_ENET	

Ball Name	Ball	Power Group	Comments
GPIO_0	E16	NVCC_GPIO	
GPIO_1	E15	NVCC_GPIO	
GPIO_16	M15	NVCC_GPIO	
GPIO_17	R16	NVCC_GPIO	
GPIO_18_PMIC_INTB	AD12	NVCC_GPIO	
GPIO_19	P16	NVCC_GPIO	
GPIO_2	D16	NVCC_GPIO	
GPIO_3	A19	NVCC_GPIO	
GPIO_4	F16	NVCC_GPIO	
GPIO_5	G16	NVCC_GPIO	
GPIO_6	H16	NVCC_GPIO	
GPIO_7	J16	NVCC_GPIO	
GPIO_8	L16	NVCC_GPIO	
GPIO_9	M16	NVCC_GPIO	
HDMI_CLKM	K19	HDMI_VPH	
HDMI_CLKP	K20	HDMI_VPH	
HDMI_D0M	J19	HDMI_VPH	
HDMI_D0P	J20	HDMI_VPH	
HDMI_D1M	G19	HDMI_VPH	
HDMI_D1P	G20	HDMI_VPH	
HDMI_D2M	F19	HDMI_VPH	
HDMI_D2P	F20	HDMI_VPH	
HDMI_HPD	K18	HDMI_VPH	
JTAG_MOD	U19	NVCC_JTAG	
JTAG_TCK	T17	NVCC_JTAG	
JTAG_TDI	V18	NVCC_JTAG	
JTAG_TDO	V17	NVCC_JTAG	
JTAG_TMS	T18	NVCC_JTAG	
JTAG_TRST_B	T16	NVCC_JTAG	
KEY_COL0	E12	NVCC_GPIO	
KEY_COL1	E13	NVCC_GPIO	
KEY_COL2	C14	NVCC_GPIO	
KEY_COL3_PMIC_SCL	W13	NVCC_GPIO	
KEY_COL4	C15	NVCC_GPIO	
KEY_ROW0	E11	NVCC_GPIO	
KEY_ROW1	F14	NVCC_GPIO	
KEY_ROW2	D14	NVCC_GPIO	
KEY_ROW3_PMIC_SDA	W12	NVCC_GPIO	
KEY_ROW4	D15	NVCC_GPIO	
LVDS0_CLK_N	B19	NVCC_LVDS_2P5	

Ball Name	Ball	Power Group	Comments
LVDS0_CLK_P	B20	NVCC_LVDS_2P5	
LVDS0_TX0_N	E19	NVCC_LVDS_2P5	
LVDS0_TX0_P	E20	NVCC_LVDS_2P5	
LVDS0_TX1_N	D19	NVCC_LVDS_2P5	
LVDS0_TX1_P	D20	NVCC_LVDS_2P5	
LVDS0_TX2_N	C19	NVCC_LVDS_2P5	
LVDS0_TX2_P	C20	NVCC_LVDS_2P5	
LVDS0_TX3_N	A18	NVCC_LVDS_2P5	
LVDS0_TX3_P	B18	NVCC_LVDS_2P5	
LVDS1_CLK_N	A16	NVCC_LVDS_2P5	
LVDS1_CLK_P	B16	NVCC_LVDS_2P5	
LVDS1_TX0_N	A17	NVCC_LVDS_2P5	
LVDS1_TX0_P	B17	NVCC_LVDS_2P5	
LVDS1_TX1_N	B15	NVCC_LVDS_2P5	
LVDS1_TX1_P	A15	NVCC_LVDS_2P5	
LVDS1_TX2_N	B14	NVCC_LVDS_2P5	
LVDS1_TX2_P	A14	NVCC_LVDS_2P5	
LVDS1_TX3_N	A13	NVCC_LVDS_2P5	
LVDS1_TX3_P	B13	NVCC_LVDS_2P5	
NANDF_ALE	U15	NVCC_NANDF	
NANDF_CLE	T15	NVCC_NANDF	
NANDF_CS0	T14	NVCC_NANDF	
NANDF_CS1	Y16	NVCC_NANDF	
NANDF_CS2	W16	NVCC_NANDF	
NANDF_CS3	U16	NVCC_NANDF	
NANDF_D0	R13	NVCC_NANDF	
NANDF_D1	T13	NVCC_NANDF	
NANDF_D2	R12	NVCC_NANDF	
NANDF_D3	T12	NVCC_NANDF	
NANDF_D4	R11	NVCC_NANDF	
NANDF_D5	T11	NVCC_NANDF	
NANDF_D6	R10	NVCC_NANDF	
NANDF_D7	T10	NVCC_NANDF	
NANDF_RB0	U14	NVCC_NANDF	
NANDF_WP_B	V16	NVCC_NANDF	
NOR_HOLD_B	V13	NVCC_EIMO	
NOR_W_B	AA13	NVCC_EIMO	
ONOFF	AD13	VDD_SNVS_IN	
PCIE_RXM	Y20	PCIE_VPH	
PCIE_RXP	Y19	PCIE_VPH	

Ball Name	Ball	Power Group	Comments
PCIE_TXM	AA19	PCIE_VPH	
PCIE_TXP	AA20	PCIE_VPH	
RGMII_RD0	N1	NVCC_RGMII	
RGMII_RD1	N2	NVCC_RGMII	
RGMII_RD2	M1	NVCC_RGMII	
RGMII_RD3	M2	NVCC_RGMII	
RGMII_RX_CTL	P2	NVCC_RGMII	
RGMII_RXC	P1	NVCC_RGMII	
RGMII_TD0	T1	NVCC_RGMII	
RGMII_TD1	T2	NVCC_RGMII	
RGMII_TD2	R1	NVCC_RGMII	
RGMII_TD3	R2	NVCC_RGMII	
RGMII_TX_CTL	U2	NVCC_RGMII	
RGMII_TXC	U1	NVCC_RGMII	
RTC_XTALI	V19	VDD_SNVS_CAP	
RTC_XTALO	V20	VDD_SNVS_CAP	
SATA_RXM	AE17	SATA_VPH	
SATA_RXP	AD17	SATA_VPH	
SATA_TXM	AE18	SATA_VPH	
SATA_TXP	AD18	SATA_VPH	
SD1_CLK	AE14	NVCC_SD1	
SD1_CMD	AD14	NVCC_SD1	
SD1_DAT0	AE16	NVCC_SD1	
SD1_DAT1	AD16	NVCC_SD1	
SD1_DAT2	AE15	NVCC_SD1	
SD1_DAT3	AD15	NVCC_SD1	
SD2_CLK	AB13	NVCC_SD2	
SD2_CMD	AC13	NVCC_SD2	
SD2_DAT0	AB14	NVCC_SD2	
SD2_DAT1	AB12	NVCC_SD2	
SD2_DAT2	AC12	NVCC_SD2	
SD2_DAT3	AC14	NVCC_SD2	
SD3_CLK	AC17	NVCC_SD3	
SD3_CMD	AC16	NVCC_SD3	
SD3_DAT0	AC18	NVCC_SD3	
SD3_DAT1	AB17	NVCC_SD3	
SD3_DAT2	AB18	NVCC_SD3	
SD3_DAT3	AA17	NVCC_SD3	
SD3_DAT4	Y17	NVCC_SD3	
SD3_DAT5	Y18	NVCC_SD3	

Ball Name	Ball	Power Group	Comments
SD3_DAT6	W17	NVCC_SD3	
SD3_DAT7	W18	NVCC_SD3	
SD3_RST	AB16	NVCC_SD3	
SD4_CLK	P9	NVCC_NANDF	
SD4_CMD	N9	NVCC_NANDF	
SD4_DAT0	N8	NVCC_NANDF	
SD4_DAT1	P8	NVCC_NANDF	
SD4_DAT2	N7	NVCC_NANDF	
SD4_DAT3	P7	NVCC_NANDF	
SD4_DAT4	N6	NVCC_NANDF	
SD4_DAT5	P6	NVCC_NANDF	
SD4_DAT6	N5	NVCC_NANDF	
SD4_DAT7	P5	NVCC_NANDF	
SYS_POR_B	AE12	VDD_SNVS_IN	
SYS_PWRON	AE13	VDD_SNVS_IN	
SYS_STBY_REQ	AB15	VDD_SNVS_IN	
TAMPER	U13	VDD_SNVS_IN	
TEST_MODE	R9	VDD_SNVS_IN	
USB_H1_DN	AD20	VDD_USB_CAP	
USB_H1_DP	AD19	VDD_USB_CAP	
USB_OTG_CHD_B	AB19	VDD_USB_CAP	
USB_OTG_DN	AC19	VDD_USB_CAP	
USB_OTG_DP	AC20	VDD_USB_CAP	
XTALI	T19	NVCC_PLL	
XTALO	T20	NVCC_PLL	

7.2. Critical Signals

The table below shows the differences between the ball map of the i.MX6 Dual and the SCM-i.MX 6Dual/6Quad.

Table 8. Signal Name differences from i.MX6 Dual

SCM-i.MX 6Dual/6Quad		i.MX6 Dual		Remarks
Ball Name	Ball	Ball Name		
EIM_D16_NOR	V3	EIM_D16		connected to SPI NOR through a 33Ohm resistor
EIM_D17_NOR	U4	EIM_D17		Connected to SPI NOR
EIM_D18_NOR	U3	EIM_D18		Connected to SPI NOR
EIM_EB2_NOR	V4	EIM_EB2		Connected to SPI NOR
GPIO_18_PMIC_INTB	AD12	GPIO_18		i.MX 6Dual/6QuadQ (GPIO18) connected to PMIC (INTB)
KEY_COL3_PMIC_SCL	W13	KEY_COL3		i.MX6DQ (KEY_COL3) tied to PMIC (SCL)
KEY_ROW3_PMIC_SDA	W12	KEY_ROW3		i.MX6DQ (KEY_ROW3) tied to PMIC (SDA)

SCM-i.MX 6Dual/6Quad		i.MX6 Dual		Remarks
Ball Name	Ball	Ball Name		
NOR_HOLD_B	V13			SPI NOR HOLD_B
NOR_W_B	AA13			SPI NOR W_B
PMIC ICTEST	Y8			PMIC ICTEST
PMIC_SDWNB	Y13			PMIC SDWNB
SYS_POR_B	AE12	POR_B		i.MX6DQ (POR_B) connected to PMIC (RESETBMCU)
SYS_PWRON	AE13	PMIC_ON_REQ		i.MX6DQ (PMIC_ON_REQ) connected to PMIC (PWRON)
SYS_STBY_REQ	AB15	PMIC_STBY_REQ		i.MX6DQ (PMIC_STBY_REQ) connected to PMIC (STANDBY)
-	-	CSI_REXT		Grounded internally
-	-	DSI_REXT		Grounded internally
-	-	FA_ANA		Grounded internally
-	-	HDMI_REF		Grounded internally
-	-	MLB_CN		Not pinned out.
-	-	MLB_CP		Not pinned out.
-	-	MLB_DN		Not pinned out.
-	-	MLB_DP		Not pinned out.
-	-	MLB_SN		Not pinned out.
-	-	MLB_SP		Not pinned out.
-	-	PCIE_REXT		Grounded internally
-	-	SATA_REXT		Grounded internally
-	-	ZQPAD		Tied to ground through 240Ohm resistor.

The table below shows the device list for ground, power, sense, and reference contact signals

Table 9. Supply Signal List for i.MX6 Dual

Supply Name	Balls	Remark
DDR_1V2	E5, E9, E14, V15	
DDR_1V2_SW3AFB	W8	
DDR_1V8	V5	
GPANAIO	U12	Test signal. Should be unconnected.
GND	A1, C16, U9, V6, W4, W9, Y4, Y5, E10, E6, E7, E8, F10, F11, F6, F7, F8, A20, F9, G10, G11, G12, G14, G6, G7, G9, H10, H11, AA12, H12, H14, H20, H9, J1, J10, J11, J12, J13, J14, AA14, J7, J8, J9, K10, K11, K12, K7, K8, K9, L10, AA15, L11, L12, L18, L7, L8, L9, R3, R6, R7, R8, AA16, U20, V10, V11, V14, V2, W11, W14, W15, Y12, Y14, AA18, Y15, AA3, AA4, AA5, AA6, AA7, AA8, AA9, AB11, AB3, AC15, AB4, AB5, AB6, AB7, AB8, AB9, AC4, AC5, AC6, AC7,	

Supply Name	Balls	Remark
	AE20, AC8, AC9, AE1, T6, T7, T8, T9, U6, U7, U8	
HDMI_DDCCEC	H19	
HDMI_VP	L14	
HDMI_VPH	K14	
LICELL	Y11	LICELL output from PMIC
NVCC_CSI	H15	
NVCC_EIM0_NOR	L5	EIM0 domain shared with the SPI NOR.
NVCC_EIM1	K5	
NVCC_EIM2	J5	
NVCC_ENET	G5	
NVCC_GPIO	G15	
NVCC_JTAG	P15	
NVCC_LCD	H5	
NVCC_LVDS2P5	F15	
NVCC_MIPI	M14	
NVCC_NANDF	P10	
NVCC_PLL_OUT	R14	
NVCC_RGMII	M5	
NVCC_SD1	M6	
NVCC_SD2	N10	
NVCC_SD3	P11	
PCIE_VP	N15	
PCIE_VPH	N12	
PCIE_VPTX	N14	
PMIC_VCOREREF	AD9	PMIC V_core_ref
PMIC_VDDOTP	Y9	PMIC VDD OTP
PMIC_VIN	AC10, AE11, AE2, AE3, V7, V8, AC11, AC2, AC3, AD10, AD11, AD2, AD3, AE10	Main system supply.
SATA_VP	N13	
SATA_VPH	N11	
SW1ABFB	AE9	
SW1ABLX	AD7, AD8, AE6, AE7, AE8	
SW1CFB	AE5	
SW1CLX	AD4, AD5, AD6, AE4	
SW2LX	W1, W2, W3, Y1, Y2, Y3	
SW3ABLX	W6, W7, Y6, Y7	
SW4LX	AA1, AA2, AB2	
SWBSTFB	Y10	
SWBSTIN	AB10	
SWBSTLX	AA10, AA11	

Supply Name	Balls	Remark
SYS_SW2FB_VIN2	V1	
SYS_SW4FB_VIN1	AB1	
SYS_VSNVS	W10	i.MX 6D/6Q (VDD_SNVS_IN) tied to PMIC (VSNVS)
USB_H1_VBUS	AE19	
USB_OTG_VBUS	AB20	
VDD_SNVS_CAP	P12	
VDDARM_CAP	M10, M11, M12	
VDDARM_IN	M7, M8, M9	
VDDARM23_CAP	K13, L13, M13	
VDDARM23_IN	J15, K15, L15	
VDDHIGH_CAP	P14	
VDDHIGH_IN	R15	
VDDPU_CAP	J6, K6, L6	
VDDSOC_CAP	F12, F13, G13, H13	
VDDSOC_IN	G8, H6, H7, H8	
VDDUSB_CAP	P13	
VGEN1	AD1	
VGEN2	AC1	
VGEN3	U5	
VGEN4	W5	
VGEN5	V9	
VGEN6	U10	

7.3. Ball Map

Table 10. Ball Map

	1	2	3	4	5	6	7	8	9	10	11	12	13	14	15	16	17	18	19	20
A	GND	DIO_PIN15	DIO_PIN4	DIO_DISP_CLK	DISPO_DAT3	DISPO_DAT7	DISPO_DAT11	DISPO_DAT15	DISPO_DAT19	DISPO_DAT23	ENET_RXD0	ENET_TXD0	LVDS1_TX3_N	LVDS1_TX2_P	LVDS1_TX1_P	LVDS1_CLK_N	LVDS1_TX0_N	LVDS0_TX3_N	GPIO_3	GND
B	EIM_BCLK	EIM_DA13	DIO_PIN3	DIO_PIN2	DISPO_DAT2	DISPO_DAT6	DISPO_DAT10	DISPO_DAT14	DISPO_DAT18	DISPO_DAT22	ENET_RXD1	ENET_TXD1	LVDS1_TX3_P	LVDS1_TX2_N	LVDS1_TX1_N	LVDS1_CLK_P	LVDS1_TX0_P	LVDS0_TX3_P	LVDS0_CLK_N	LVDS0_CLK_P
C	EIM_DA8	EIM_DA14	EIM_DA15	EIM_DA12	DISPO_DAT1	DISPO_DAT5	DISPO_DAT9	DISPO_DAT13	DISPO_DAT17	DISPO_DAT21	ENET_RX_ER	ENET_MDIO	ENET_REF_CLK	KEY_COL2	KEY_COL4	GND	CSIO_PIXCLK	CSIO_MCLK	LVDS0_TX2_N	LVDS0_TX2_P
D	EIM_DA5	EIM_DA10	EIM_DA9	EIM_DA11	DISPO_DAT0	DISPO_DAT4	DISPO_DAT8	DISPO_DAT12	DISPO_DAT16	DISPO_DAT20	ENET_CRS_DV	ENET_MDC	ENET_TX_EN	KEY_ROW2	KEY_ROW4	GPIO_2	CSIO_VSYNC	CSIO_DATA_EN	LVDS0_TX1_N	LVDS0_TX1_P

U	T	R	P	N	M	L	K	J	H	G	F	E
RGMII_TXC	RGMII_TD0	RGMII_TD2	RGMII_RXC	RGMII_RD0	RGMII_RD2	EIM_D31	EIM_A21	GND	EIM_A16	EIM_OE	EIM_LBA	EIM_DAO
RGMII_TX_CT	RGMII_TD1	RGMII_TD3	RGMII_RX_CT	RGMII_RD1	RGMII_RD3	EIM_D30	EIM_A22	EIM_A18	EIM_CS1	EIM_FB1	EIM_DA2	EIM_DA4
EIM_D18_NO	EIM_D20	GND	EIM_D22	EIM_D25	EIM_D27	EIM_D29	EIM_A23	EIM_A19	EIM_CS0	EIM_EB0	EIM_DA3	EIM_DA7
EIM_D17_NO	EIM_D19	EIM_D21	EIM_D23	EIM_EB3	EIM_D26	EIM_D28	EIM_A24	EIM_A20	EIM_A17	EIM_RW	EIM_DA1	EIM_DA6
VGEN3	EIM_D24	EIM_A25	SD4_DAT7	SD4_DAT6	NVCC_RGMII	NVCC_EIM0_NOR	NVCC_EIM1	NVCC_EIM2	NVCC_LCD	NVCC_ENET	EIM_WAIT	DDR_1V2
GND	GND	GND	SD4_DAT5	SD4_DAT4	NVCC_SD1	VDDPU_CAP	VDDPU_CAP	VDDPU_CAP	VDDSOC_IN	GND	GND	GND
GND	GND	GND	SD4_DAT3	SD4_DAT2	VDDARM_IN	GND	GND	GND	VDDSOC_IN	GND	GND	GND
GND	GND	GND	SD4_DAT1	SD4_DAT0	VDDARM_IN	GND	GND	GND	VDDSOC_IN	VDDSOC_IN	GND	GND
GND	GND	TEST_MODE	SD4_CLK	SD4_CMD	VDDARM_IN	GND	GND	GND	GND	GND	GND	DDR_1V2
VGEN6	NANDF_D7	NANDF_D6	NVCC_NANDF	NVCC_SD2	VDDARM_CA	GND	GND	GND	GND	GND	GND	GND
BOOT_MODE	NANDF_D5	NANDF_D4	NVCC_SD3	SATA_VPH	VDDARM_CA	GND	GND	GND	GND	GND	GND	KEY_ROW0
GPANAIO	NANDF_D3	NANDF_D2	VDD_SNV5_C	PCIE_VPH	VDDARM_CA	GND	GND	GND	GND	GND	VDDSOC_CAP	KEY_COLO
TAMPER	NANDF_D1	NANDF_D0	VDDUSB_CAP	SATA_VP	VDDARM23_CAP	VDDARM23_CAP	VDDARM23_CAP	GND	VDDSOC_CAP	VDDSOC_CAP	VDDSOC_CAP	KEY_COL1
NANDF_RB0	NANDF_CS0	NVCC_PLL_O	VDDHIGH_CAP	PCIE_VPTX	NVCC_MIPI	HDMI_VP	HDMI_VPH	GND	GND	GND	KEY_ROW1	DDR_1V2
NANDF_ALE	NANDF_CLE	VDDHIGH_IN	NVCC_JTAG	PCIE_VP	GPIO_16	VDDARM23_N	VDDARM23_N	VDDARM23_N	NVCC_CSI	NVCC_GPIO	NVCC_LVDS2_P5	GPIO_1
NANDF_CS3	JTAG_TRST_B	GPIO_17	GPIO_19	CSIO_DAT16	GPIO_9	GPIO_8	CSIO_DAT15	GPIO_7	GPIO_6	GPIO_5	GPIO_4	GPIO_0
CLK1_P	JTAG_TCK	DSI_D0M	DSI_CLK0P	DSI_D1M	CSIO_DAT19	CSIO_DAT18	CSIO_DAT14	CSIO_DAT12	CSIO_DAT10	CSIO_DAT8	CSIO_DAT6	CSIO_DAT4
CLK1_N	JTAG_TMS	DSI_D0P	DSI_CLK0M	DSI_D1P	CSIO_DAT17	GND	HDMI_HPD	CSIO_DAT13	CSIO_DAT11	CSIO_DAT9	CSIO_DAT7	CSIO_DAT5
JTAG_MOD	XTALI	CSIO_D0M	CSIO_D1M	CSIO_CLK0P	CSIO_D2M	CSIO_D3P	HDMI_CLKM	HDMI_D0M	HDMI_DDCC_EC	HDMI_D1M	HDMI_D2M	LVDS0_TX0_N
GND	XTALO	CSIO_D0M	CSIO_D1P	CSIO_CLK0M	CSIO_D2P	CSIO_D3M	HDMI_CLKP	HDMI_D0P	GND	HDMI_D1P	HDMI_D2P	LVDS0_TX0_P

	AE	AD	AC	AB	AA	Y	W	V
	GND	VGEN1	VGEN2	SYS_SW4FB_VIN1	SW4LX	SW2LX	SW2LX	SYS_SW2FB_VIN2
	PMIC_VIN	PMIC_VIN	PMIC_VIN	SW4LX	SW4LX	SW2LX	SW2LX	GND
	PMIC_VIN	PMIC_VIN	PMIC_VIN	GND	GND	SW2LX	SW2LX	EIM_D16_NO_R
	SW1CLX	SW1CLX	GND	GND	GND	GND	GND	EIM_EB2_NO_R
	SW1CFB	SW1CLX	GND	GND	GND	GND	VGEN4	DDR_1V8
	SW1ABXL	SW1CLX	GND	GND	GND	SW3ABXL	SW3ABXL	GND
	SW1ABXL	SW1ABXL	GND	GND	GND	SW3ABXL	SW3ABXL	PMIC_VIN
	SW1ABXL	SW1ABXL	GND	GND	GND	PMIC_ICTEST	DDR_1V2_SW3AFB	PMIC_VIN
	SW1ABFB	PMIC_VCORE_REF	GND	GND	GND	PMIC_VDDOT_P	GND	VGEN5
	PMIC_VIN	PMIC_VIN	PMIC_VIN	SWBSTIN	SWBSTLX	SWBSTFB	SYS_V5NV5	GND
	PMIC_VIN	PMIC_VIN	PMIC_VIN	GND	SWBSTLX	LICELL	GND	GND
	SYS_POR_B	GPIO_18_PMIC_INTB	SD2_DAT2	SD2_DAT1	GND	GND	KEY_ROW3_PMIC_SDA	BOOT_MODE1
	SYS_PWRON	ONOFF	SD2_CMD	SD2_CLK	NOR_W_B	PMIC_SDWNB	KEY_COL3_PMIC_SCL	NOR_HOLD_B
	SD1_CLK	SD1_CMD	SD2_DAT3	SD2_DAT0	GND	GND	GND	GND
	SD1_DAT2	SD1_DAT3	GND	SYS_STBY_REQ	GND	GND	GND	DDR_1V2
	SD1_DAT0	SD1_DAT1	SD3_CMD	SD3_RST	GND	NANDF_CS1	NANDF_CS2	NANDF_WP_B
	SATA_RXM	SATA_RXP	SD3_CLK	SD3_DAT1	SD3_DAT3	SD3_DAT4	SD3_DAT6	JTAG_TDO
	SATA_TXM	SATA_TXP	SD3_DAT0	SD3_DAT2	GND	SD3_DAT5	SD3_DAT7	JTAG_TDI
	USB_H1_VBUS	USB_H1_DP	USB_OTG_DN	USB_OTG_CHD_B	PCIE_TXM	PCIE_RXP	CLK_N	RTC_XTALI
	GND	USB_H1_DN	USB_OTG_DP	USB_OTG_VBUS	PCIE_TXP	PCIE_RXM	CLK_P	RTC_XTALO

7.4. Package Drawings

Figure 4. SCM-i.MX 6Dual/6Quad without Memory



© NXP SEMICONDUCTORS N.V. ALL RIGHTS RESERVED.
ELECTRONIC VERSIONS ARE UNCONTROLLED EXCEPT WHEN
ACCESSED DIRECTLY FROM THE DOCUMENT CONTROL REPOSITORY.
PRINTED VERSIONS ARE UNCONTROLLED EXCEPT WHEN STAMPED
"CONTROLLED COPY" IN RED.

MECHANICAL OUTLINE

DO NOT SCALE THIS DRAWING

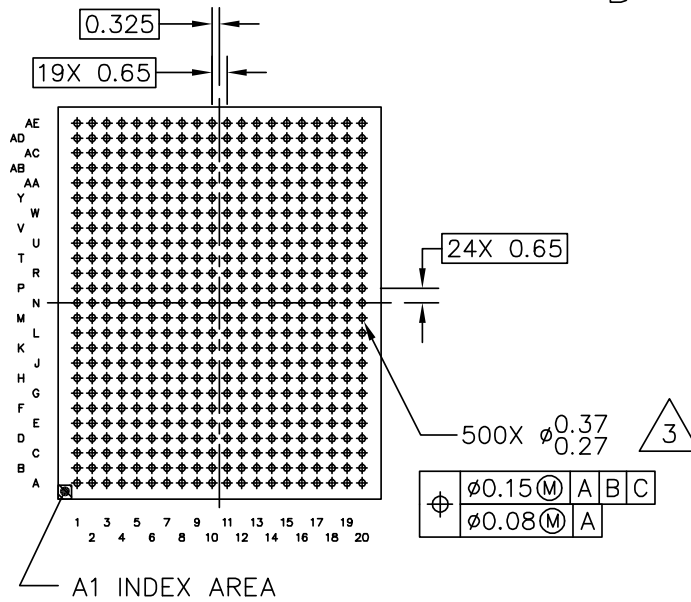
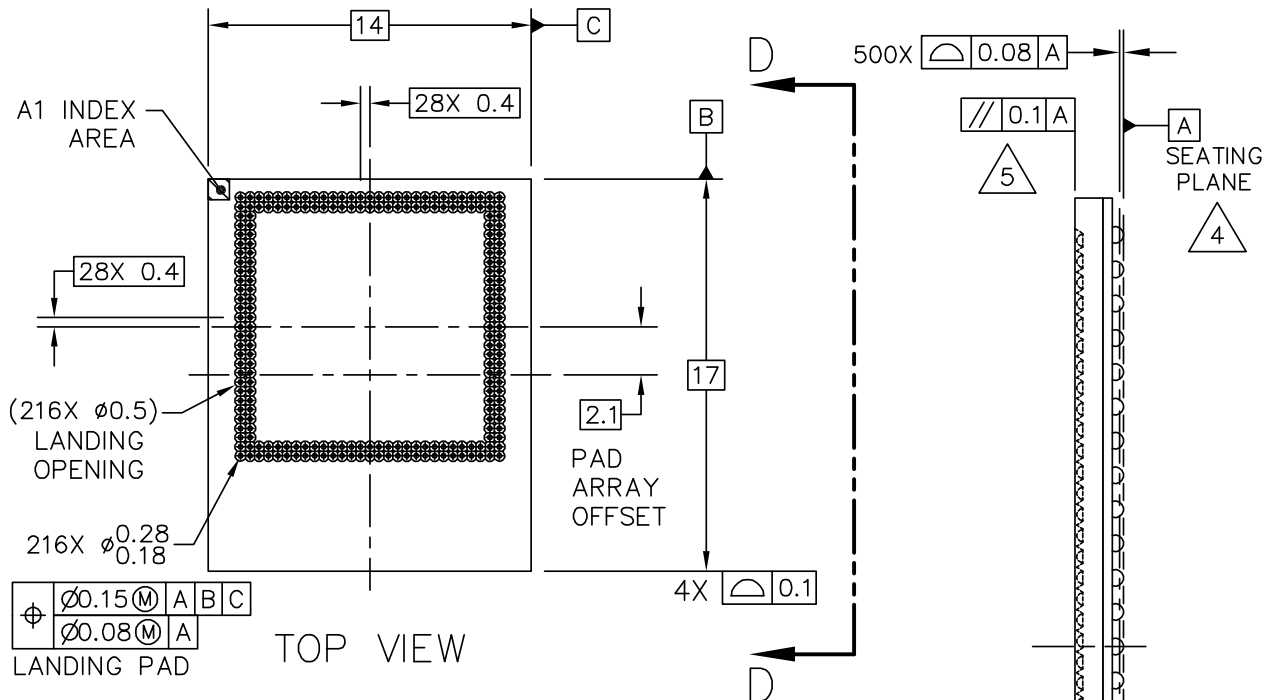

BOTTOM VIEW

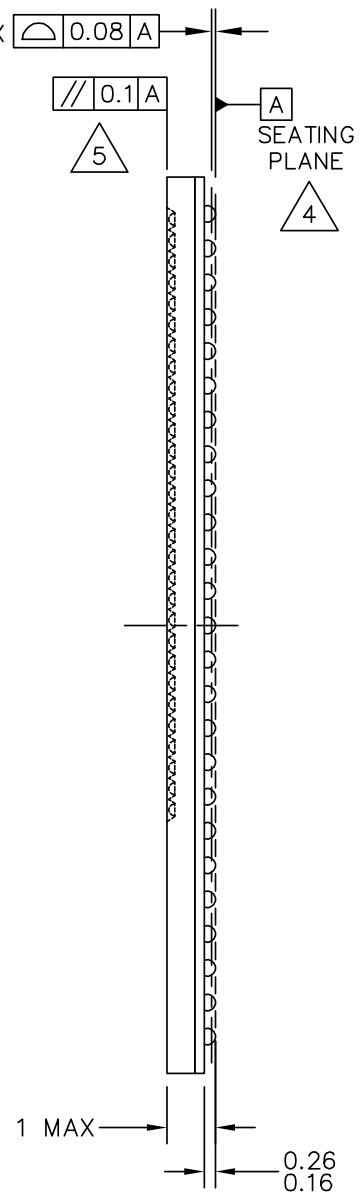

VIEW D-D

RELEASED FOR EXTERNAL ASSEMBLY ONLY. THIS DESIGN ONLY MEETS EXTERNAL DESIGN AND ASSEMBLY RULES.
MUST BE REVIEWED AND UPDATED BEFORE BEING ASSEMBLED INTERNALLY.

TITLE: FLIP CHIP SIP STACKABLE,
14 X 17 X 0.92 PKG,
0.65 MM PITCH, 500 I/O

DOCUMENT NO: 98ASA00965D

REV: 0

STANDARD: NON-JEDEC

SOT1690-2

SHEET: 1 OF 3



© NXP SEMICONDUCTORS N.V. ALL RIGHTS RESERVED.
ELECTRONIC VERSIONS ARE UNCONTROLLED EXCEPT WHEN
ACCESSED DIRECTLY FROM THE DOCUMENT CONTROL REPOSITORY.
PRINTED VERSIONS ARE UNCONTROLLED EXCEPT WHEN STAMPED
"CONTROLLED COPY" IN RED.

MECHANICAL OUTLINE

DO NOT SCALE THIS DRAWING

NOTES:

1. ALL DIMENSIONS IN MILLIMETERS.
2. DIMENSIONING AND TOLERANCING PER ASME Y14.5M-1994.
3. MAXIMUM SOLDER BALL DIAMETER MEASURED PARALLEL TO DATUM A.
4. DATUM A, THE SEATING PLANE, IS DETERMINED BY THE SPHERICAL CROWNS OF THE SOLDER BALLS.
5. PARALLELISM MEASUREMENT SHALL EXCLUDE ANY EFFECT OF MARK ON TOP SURFACE OF PACKAGE.
6. SCORING OR GROOVES ON TOP SURFACE OF PACKAGE IS NOT PERMITTED.
7. NO VOIDS IN ENCAPSULATION PERMITTED.

TITLE: FLIP CHIP SIP STACKABLE,
14 X 17 X 0.92 PKG,
0.65 MM PITCH, 500 I/O

DOCUMENT NO: 98ASA00965D REV: 0

STANDARD: NON-JEDEC

SOT1690-2 SHEET: 2



© NXP SEMICONDUCTORS N.V. ALL RIGHTS RESERVED.
 ELECTRONIC VERSIONS ARE UNCONTROLLED EXCEPT WHEN
 ACCESSED DIRECTLY FROM THE DOCUMENT CONTROL REPOSITORY.
 PRINTED VERSIONS ARE UNCONTROLLED EXCEPT WHEN STAMPED
 "CONTROLLED COPY" IN RED.

REVISION HISTORY

LTR	ORIGINATOR	REVISIONS	DRAFTER	DATE
0	AKHIL SINGH	RELEASED FOR PRODUCTION. (DAR #25395)	S. ZANG	09 APR 2016

TITLE: FLIP CHIP SIP STACKABLE,
 14 X 17 X 0.92 PKG,
 0.65 MM PITCH, 500 I/O

DOCUMENT NO: 98ASA00965D REV: 0

STANDARD: NON-JEDEC

SOT1690-2 SHEET: 3

8. Revision History

Revision	Date	Change description
0	01/2017	Technical Data Sheet

How to Reach Us:

Home Page:
NXP.com

Web Support:
NXP.com/support

Information in this document is provided solely to enable system and software Implementers to use NXP products. There are no express or implied copyright licenses granted hereunder to design or fabricate any integrated circuits based on the information in this document. NXP reserves the right to make changes without further notice to any products herein.

NXP makes no warranty, representation, or guarantee regarding the suitability of its products for any particular purpose, nor does NXP assume any liability arising out of the application or use of any product or circuit, and specifically disclaims any and all liability, including without limitation consequential or incidental damages. "Typical" parameters that may be provided in NXP data sheets and/or specifications can and do vary in different applications, and actual performance may vary over time. All operating parameters, including "typicals," must be validated for each customer application by customer's technical experts. NXP does not convey any license under its patent rights nor the rights of others. NXP sells products pursuant to standard terms and conditions of sale, which can be found at the following address: NXP.com/SalesTermsandConditions.

NXP and the NXP logo are trademarks of NXP B.V. Inc., Reg. U.S. Pat. & Tm. Off. ARM, the ARM Power logo, and Cortex are registered trademarks of ARM Limited (or its subsidiaries) in the EU and/or elsewhere. All other product or service names are the property of their respective owners.

© 2017 NXP B.V



Document Number: SCMIMX6DQIEC
Rev. 0
01/2017



Mouser Electronics

Authorized Distributor

Click to View Pricing, Inventory, Delivery & Lifecycle Information:

NXP:

[MSCMMX6QZDK08AB](#)