

2°C Accurate Remote/Local Temperature Sensor with SMBus Serial Interface

ABSOLUTE MAXIMUM RATINGS

(All voltages are referenced to GND unless otherwise noted.)
 V_{CC}-0.3V to +6V
 DXP, ADD_-0.3V to (V_{CC} + 0.3V)
 DXN-0.3V to +0.8V
 SMBCLK, SMBDATA, ALERT, STBY_-0.3V to +6V
 SMBDATA, ALERT Current-1mA to +50mA
 DXN Current±1mA
 ESD Protection (all pins, Human Body Model)2000V

Continuous Power Dissipation (T_A = +70°C)
 16-Pin QSOP (derate 8.30mW/°C above +70°C).....667mW
 Operating Temperature Range-55°C to +125°C
 Junction Temperature+150°C
 Storage Temperature Range-65°C to +165°C
 Lead Temperature (soldering, 10s)+300°C

Stresses beyond those listed under "Absolute Maximum Ratings" may cause permanent damage to the device. These are stress ratings only, and functional operation of the device at these or any other conditions beyond those indicated in the operational sections of the specifications is not implied. Exposure to absolute maximum rating conditions for extended periods may affect device reliability.

ELECTRICAL CHARACTERISTICS

(V_{CC} = +3V to +5.5V, T_A = -55°C to +125°C, unless otherwise noted. Typical values are at V_{CC} = +3.3V and T_A = +25°C.)

PARAMETER	SYMBOL	CONDITIONS	MIN	TYP	MAX	UNITS
TEMPERATURE-TO-DIGITAL CONVERTER						
Accuracy (Local Sensor)		+60°C ≤ T _A ≤ +100°C, V _{CC} = +3.3V	-2.5		+2.5	°C
		0°C ≤ T _A ≤ +100°C, V _{CC} = +3.3V	-3.5		+3.5	
		-55°C ≤ T _A ≤ +120°C, V _{CC} = +3.3V	-5.0		+5.0	
Accuracy (Remote Sensor)		+70°C ≤ T _{RJ} ≤ +100°C, V _{CC} = +3.3V (Note 1)	-2		+2	°C
		0°C ≤ T _{RJ} ≤ +100°C, V _{CC} = +3.3V (Note 1)	-3.5		+3.5	
		-55°C ≤ T _{RJ} ≤ +120°C, V _{CC} = +3.3V (Notes 1, 2)	-5		+5	
Line Regulation				0.2	0.5	°C
Resolution (Legacy Mode)		Conversion rate >1Hz	+1			°C
			+8			Bits
Resolution (Extended Mode)		Conversion rate ≤1Hz	+0.125			°C
			+11			Bits
Undervoltage Lockout Threshold	UVLO	V _{CC} input, disables A/D conversion, rising edge	+2.60	+2.80	+2.95	V
Undervoltage Lockout Hysteresis			+90			mV
Supply Voltage Range	V _{CC}		+3.0		+5.5	V
Power-On Reset (POR) Threshold		V _{CC} , falling edge	+1.5	+2.0	+2.5	V
POR Threshold Hysteresis			+90			mV
Standby Current		SMBus static		+3	+10	μA
Operating Current		During conversion		+0.55	+1	mA
Average Operating Current		0.25 conversion/s (Note 3)		+40	+70	μA
		2 conversion/s (Note 3)		+150	+250	
Conversion Time	t _{CONV}	From stop bit to conversion completed, in legacy mode (Note 3)	+95	+125	+156	ms
Conversion Timing Error			±25			%
Remote-Diode Current	I _{RJ}	High level	+80	+100	+120	μA
		Low level	+8	+10	+12	

2°C Accurate Remote/Local Temperature Sensor with SMBus Serial Interface

MAX6690

ELECTRICAL CHARACTERISTICS (continued)

($V_{CC} = +3V$ to $+5.5V$, $T_A = -55^\circ C$ to $+125^\circ C$, unless otherwise noted. Typical values are at $V_{CC} = +3.3V$ and $T_A = +25^\circ C$.)

PARAMETER	SYMBOL	CONDITIONS	MIN	TYP	MAX	UNITS
Logic Input Low Voltage	V_{IL}	$V_{CC} = +3.0V$ to $+5.5V$			+0.8	V
Logic Input High Voltage	V_{IH}	$V_{CC} = +3.0V$	+2.2			V
		$V_{CC} = +5.5V$	+2.6			
Input Leakage Current	I_{LEAK}	$V_{IN} = GND$ or V_{CC}			± 2	μA
Output Low Sink Current	I_{OL}	$V_{OL} = +0.6V$	+6			mA
		$V_{OL} = +0.4V$	+1			
Input Capacitance	C_{IN}			+5		pF
Output High Leakage Current		$V_{OH} = +5.5V$			+1	μA
Serial Clock Frequency	f_{SCL}	(Note 4)	0		+100	kHz
Bus Free Time Between STOP and START Conditions	t_{BUF}		+4.7			μs
START Condition Setup Time			+4.7			μs
Repeat START Condition Setup Time	$t_{SU:STA}$	90% to 90%	+50			μs
START Condition Hold Time	$t_{HD:STA}$	10% of SMBDATA to 90% of SMBCLK	+4			μs
STOP Condition Setup Time	$t_{SU:STO}$	90% of SMBCLK to 10% of SMBDATA662	+4			μs
Clock Low Period	t_{LOW}	10% to 10%	+4.7			μs
Clock High Period	t_{HIGH}	90% to 90%	+4			μs
Data Setup Time	$t_{SU:DAT}$	90% of SMBDATA to 10% of SMBCLK	+250			ns
Data Hold Time	$t_{HD:DAT}$	(Note 5)	0			μs
Receive SCL/SDA Rise Time	t_R				+1	μs
Receive SCL/SDA Fall Time	t_F				+300	ns
SMBus Timeout	$t_{TIMEOUT}$	SMBDATA and SMBCLK time low for reset of serial interface	+25		+40	ms

Note 1: $+25^\circ C \leq T_A \leq +85^\circ C$.

Note 2: If both the MAX6690 and the remote junction are below $T_A = -20^\circ C$, then $V_{CC} > 3.15V$.

Note 3: The conversion time doubles for the extended resolution mode. This causes the average operating current to approximately double.

Note 4: The serial interface resets when SMBCLK is low for more than $t_{TIMEOUT}$.

Note 5: Note that a transition must internally provide at least a hold time to bridge the undefined region (300ns max) of SMBCLK's falling edge.

2°C Accurate Remote/Local Temperature Sensor with SMBus Serial Interface

Typical Operating Characteristics

(V_{CC} = +3.3V to +5.5V, T_A = +25°C, unless otherwise noted.)

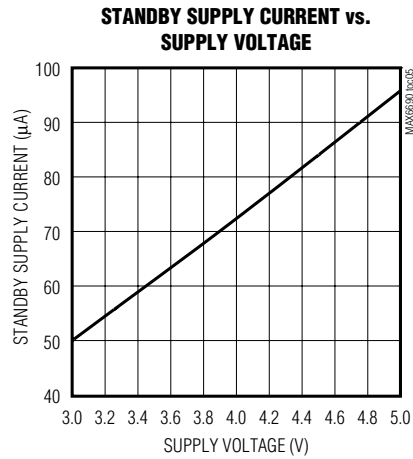
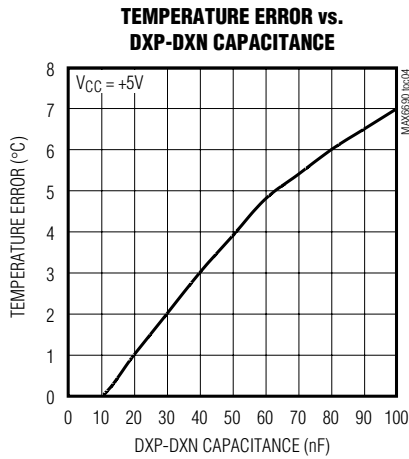
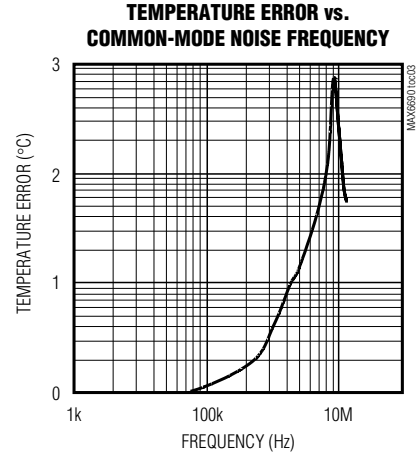
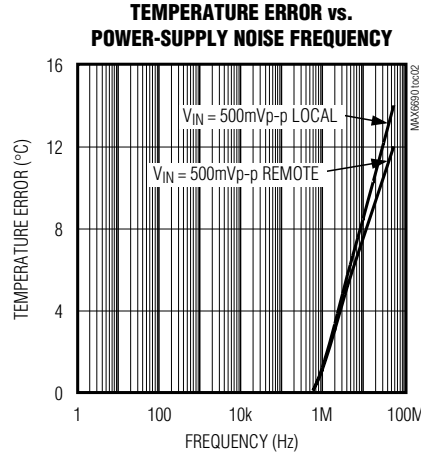
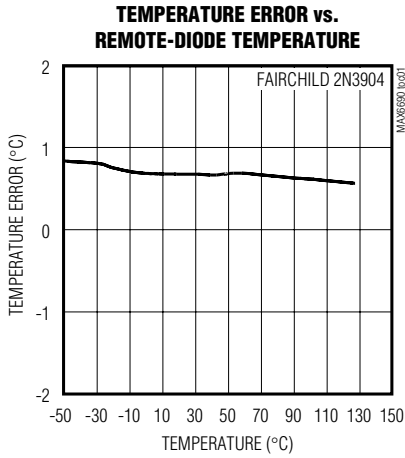

2°C Accurate Remote/Local Temperature Sensor with SMBus Serial Interface

Pin Description

PIN	NAME	FUNCTION
1, 5, 9, 13, 16	N.C.	No Connection. Not internally connected. May be used for PC board trace routing.
2	VCC	Supply Voltage Input. +3.0V to +5.5V. Bypass to GND with a 0.1μF capacitor. A 200Ω series resistor is recommended but not required for additional noise filtering.
3	DXP	Combined Current Source and ADC Positive Input for Remote-Junction Channel. If a remote-sensing junction is not used, connect DXP to DXN.
4	DXN	Combined Current Sink and ADC Negative Input. DXN is internally biased to a diode voltage above ground.
6	ADD1	SMBus Slave Address Select Input. ADD0 and ADD1 are sampled upon power-up.
7, 8	GND	Ground
10	ADD0	SMBus Slave Address Select Input. ADD0 and ADD1 are sampled upon power-up.
11	$\overline{\text{ALERT}}$	SMBus Alert (Interrupt) Output. Open drain.
12	SMBDATA	SMBus Serial-Data Input/Output. Open drain.
14	SMBCLK	SMBus Serial-Clock Input
15	$\overline{\text{STBY}}$	Hardware Standby Input. Temperature and comparison threshold data are retained in standby mode. Low = standby mode, high = operating mode.

MAX6690

2°C Accurate Remote/Local Temperature Sensor with SMBus Serial Interface

Detailed Description

The MAX6690 is a temperature sensor that communicates through an SMBus/I²C-compatible interface with a μ P in thermal-management applications. Essentially an 11-bit serial analog-to-digital converter (ADC) with a sophisticated front end, the MAX6690 measures the change in diode voltage at different current levels to calculate temperature. It contains a current source, a multiplexer, an ADC, an SMBus interface, and associated control logic (Figure 1). Temperature data from the ADC is loaded into data registers, where it is automatically compared with data previously stored in four over/undertemperature alarm registers.

ADC and Multiplexer

The ADC is an averaging type that integrates over a 60ms period (each channel, typically, in the 8-bit “legacy” mode), with excellent noise rejection.

The multiplexer automatically steers bias currents through the remote and local diodes. The ADC and associated circuitry measure their forward voltages and compute their temperatures. Both channels are automatically converted once the conversion process has started, either in free-running or single-shot mode. If one of the two channels is not used, the device still performs both measurements, and the user can ignore the results of the unused channel. If the remote-diode channel is unused, connect DXP to DXN rather than leave the pins open.

The DXN input is biased at $1V_{BE}$ above ground by an internal diode to set up the ADC inputs for a differential measurement. The worst-case DXP-DXN differential input voltage range is 0.28V to 0.9V.

Excess resistance in series with the remote diode causes about $+1/2^\circ\text{C}$ error per ohm when the parasitic resistance cancellation mode is not being used. When the parasitic resistance cancellation mode is being used, excess resistance of up to 100Ω does not cause any discernable error. A $200\mu\text{V}$ offset voltage forced on DXP-DXN causes about 1°C error.

A/D Conversion Sequence

A conversion sequence consists of a local temperature measurement and a remote-temperature measurement. Each time a conversion begins, whether initiated automatically in the free-running autoconvert mode (RUN/STOP = 0) or by writing a “One-Shot” command, both channels are converted, and the results of both measurements are available after the end of conversion. A BUSY status bit in the status byte shows that the device is actually performing a new conversion; however, even if the ADC is busy, the results of the previous conversion are always available.

Table 1. Remote-Sensor Transistor Manufacturers

MANUFACTURER	MODEL NO.
Central Semiconductor (USA)	CMPT3904
Fairchild Semiconductor (USA)	2N3904, 2N3906
ON Semiconductor (USA)	2N3904, 2N3906
Rohm Semiconductor (USA)	SST3904
Samsung (Korea)	KST3904-TF
Siemens (Germany)	SMBT3904
Zetex (England)	FMMT3904CT-ND

Note: Transistors must be diode connected (base shorted to collector).

Remote-Diode Selection

The MAX6690 can directly measure the die temperature of CPUs and other ICs having on-board temperature-sensing diodes as shown in the *Typical Operating Circuit*, or it can measure the temperature of a discrete diode-connected transistor. For best accuracy, the discrete transistor should be a small-signal device with its collector and base connected together. Accuracy has been experimentally verified for all of the devices listed in Table 1.

The transistor must be a small-signal type with a relatively high forward voltage; otherwise, the A/D input voltage range can be violated. The forward voltage must be $>0.28\text{V}$ at $10\mu\text{A}$; check to ensure this is true at the highest expected temperature. The forward voltage must be $<0.9\text{V}$ at $100\mu\text{A}$; check to ensure this is true at the lowest expected temperature. Large power transistors don't work at all. Also, ensure that the base resistance is $<100\Omega$. Tight specifications for forward-current gain ($+50$ to $+150$, for example) indicate that the manufacturer has good process controls and that the devices have consistent V_{BE} characteristics.

For heat-sink mounting, the 500-32BT02-000 thermal sensor from Fenwal Electronics is a good choice. This device consists of a diode-connected transistor, an aluminum plate with screw hole, and twisted-pair cable (Fenwal Inc., Milford, MA, 508-478-6000).

Thermal Mass and Self-Heating

Thermal mass can significantly affect the time required for a temperature sensor to respond to a sudden change in temperature. The thermal time constant of the 16-pin QSOP package is about 140s in still air. For the junction temperature of a MAX6690 in still air to settle to within $+1^\circ\text{C}$ after a sudden $+100^\circ\text{C}$ change in air temperature, about five time constants or 12 minutes are required. However, the MAX6690 is not intended to

2°C Accurate Remote/Local Temperature Sensor with SMBus Serial Interface

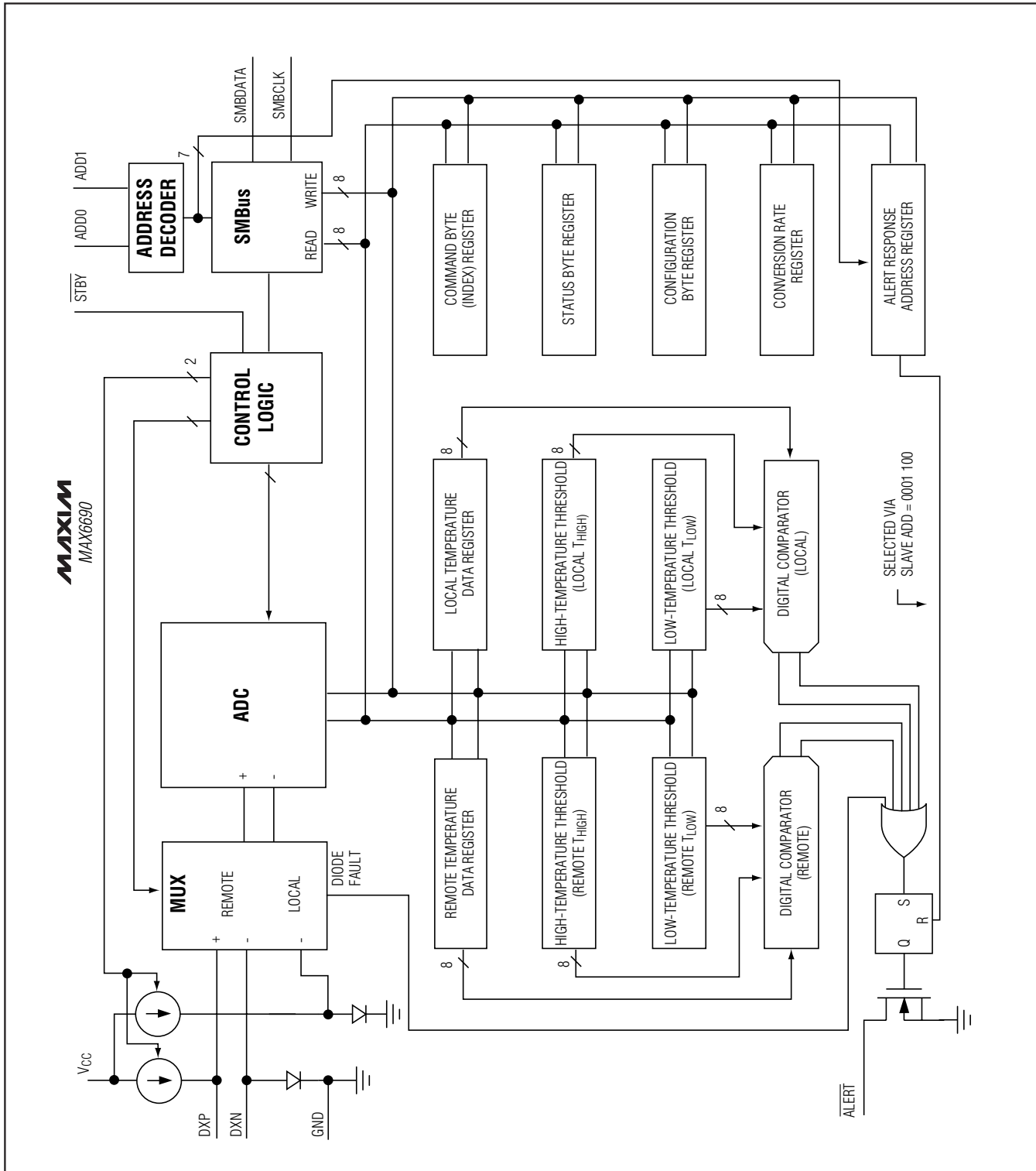

MAX6690

Figure 1. Functional Diagram

2°C Accurate Remote/Local Temperature Sensor with SMBus Serial Interface

measure ambient temperature; when measuring local temperature, it senses the temperature of the PC board to which it is soldered. The leads provide a good thermal path between the PC board traces and the MAX6690's die. Thermal conductivity between the MAX6690's die and the ambient air is poor by comparison. Because the thermal mass of the PC board is far greater than that of the MAX6690, the device follows temperature changes on the PC board with little or no perceivable delay.

When measuring temperature with discrete remote sensors, the use of smaller packages, such as SOT23s, yields the best thermal response times. Take care to account for thermal gradients between the heat source and the sensor, and ensure that stray air currents across the sensor package do not interfere with measurement accuracy. When measuring the temperature of a CPU or other IC with an on-chip sense junction, thermal mass has virtually no effect; the measured temperature of the junction tracks the actual temperature within a conversion cycle.

Self-heating does not significantly affect measurement accuracy. Remote-sensor self-heating due to the diode current source is negligible. For the local diode, the worst-case error occurs when autoconverting at the fastest rate and simultaneously sinking maximum current at the $\overline{\text{ALERT}}$ output. For example, at an 8Hz rate and with $\overline{\text{ALERT}}$ sinking 1mA, the typical power dissipation is $V_{CC} \times 450\mu\text{A} + 0.4\text{V} \times 1\text{mA}$. Package theta J-A is about $150^\circ\text{C}/\Omega$, so with $V_{CC} = 5\text{V}$ and no copper PC board heat sinking, the resulting temperature rise is:

$$\Delta T = 2.7\text{mW} \times 150^\circ\text{C}/\text{W} = 0.4^\circ\text{C}$$

Even with these contrived circumstances, it is difficult to introduce significant self-heating errors.

ADC Noise Filtering

The ADC is an integrating type with inherently good noise rejection, especially of low-frequency signals such as 60Hz/120Hz power-supply hum. Micropower operation places constraints on high-frequency noise rejection; therefore, careful PC board layout and proper external noise filtering are required for high-accuracy remote measurements in electrically noisy environments.

High-frequency EMI is best filtered at DXP and DXN with an external 2200pF capacitor. This value can be increased to about 3300pF (max), including cable capacitance. Capacitance >3300pF introduces errors due to the rise time of the switched current source. Nearly all noise sources tested cause the ADC measurements to be higher than the actual temperature, typically by +1°C to +10°C, depending on the frequency and amplitude (see *Typical Operating Characteristics*).

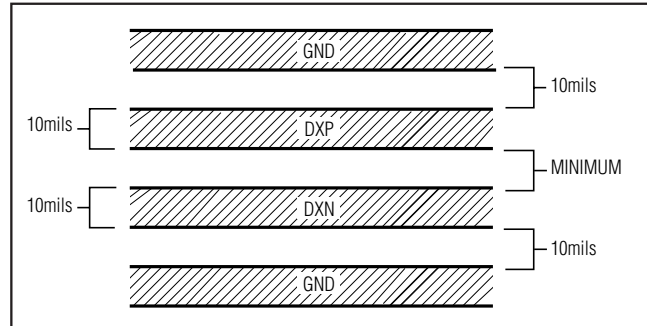

Figure 2. Recommended DXP/DXN PC Traces

PC Board Layout

- 1) Place the MAX6690 as close as practical to the remote diode. In a noisy environment, such as a computer motherboard, this distance can be 4in to 8in (typ) or more, as long as the worst noise sources (such as CRTs, clock generators, memory buses, and ISA/PCI buses) are avoided.
- 2) Do not route the DXP-DXN lines next to the deflection coils of a CRT. Also, do not route the traces across a fast memory bus, which can easily introduce +30°C error, even with good filtering. Otherwise, most noise sources are fairly benign.
- 3) Route the DXP and DXN traces in parallel and in close proximity to each other, away from any high-voltage traces, such as +12VDC. Leakage currents from PC board contamination must be dealt with carefully since a 20MΩ leakage path from DXP to ground causes about +1°C error.
- 4) Connect guard traces to GND on either side of the DXP-DXN traces (Figure 2). With guard traces in place, routing near high-voltage traces is no longer an issue.
- 5) Route through as few vias and crossunders as possible to minimize copper/solder thermocouple effects.
- 6) When introducing a thermocouple, make sure that both the DXP and the DXN paths have matching thermocouples. In general, PC-board-induced thermocouples are not a serious problem. A copper-solder thermocouple exhibits $3\mu\text{V}/^\circ\text{C}$, and it takes about 200μV of voltage error at DXP-DXN to cause a +1°C measurement error. So, most parasitic thermocouple errors are swamped out.
- 7) Use wide traces. Narrow traces are more inductive and tend to pick up radiated noise. The 10mil widths and spacings recommended in Figure 2 aren't absolutely necessary (as they offer only a

2°C Accurate Remote/Local Temperature Sensor with SMBus Serial Interface

minor improvement in leakage and noise), but try to use them where practical.

- 8) Keep in mind that copper can't be used as an EMI shield, and only ferrous materials such as steel work well. Placing a copper ground plane between the DXP-DXN traces and traces carrying high-frequency noise signals does not help reduce EMI.

PC Board Layout Checklist

- Place the MAX6690 close to the remote-sense junction.
- Keep traces away from high voltages (+12V bus).
- Keep traces away from fast data buses and CRTs.
- Use recommended trace widths and spacings.
- Place a ground plane under the traces.
- Use guard traces flanking DXP and DXN and connecting to GND.
- Place the noise filter and the 0.1 μ F V_{CC} bypass capacitors close to the MAX6690.
- Add a 200 Ω resistor in series with V_{CC} for best noise filtering (see *Typical Operating Circuit*).

Twisted-Pair and Shielded Cables

For remote-sensor distances longer than 8in, or in particularly noisy environments, a twisted pair is recommended. Its practical length is 6ft to 12ft (typ) before noise becomes a problem, as tested in a noisy electronics laboratory. For longer distances, the best solution is a shielded twisted pair like that used for audio microphones. For example, Belden #8451 works well for distances up to 100ft in a noisy environment. Connect the twisted pair to DXP and DXN and the shield to GND, and leave the shield's remote end unterminated.

Excess capacitance at DXN and DXP limits practical remote-sensor distances (see *Typical Operating Characteristics*). For very long cable runs, the cable's parasitic capacitance often provides noise filtering, so the 2200pF capacitor can often be removed or reduced in value.

Cable resistance also affects remote-sensor accuracy; 1 Ω series resistance introduces about +1/2°C error. Setting bit 4 of the configuration register to 1 invokes the parasitic resistance cancellation mode. This rejects external resistance in excess of 100 Ω while maintaining conversion accuracy.

Low-Power Standby Mode

Standby mode disables the ADC and reduces the supply-current drain to less than 10 μ A. Enter standby mode by forcing the STBY/pin low or through the

RUN/STOP bit in the configuration byte register. Hardware and software standby modes behave almost identically; all data is retained in memory, and the SMB interface is alive and listening for reads and writes. The only difference is that in hardware standby mode, the one-shot command does not initiate a conversion.

Standby mode is not a shutdown mode. With activity on the SMBus, extra supply current is drawn (see *Typical Operating Characteristics*). In software standby mode, the MAX6690 can be forced to perform A/D conversions through the one-shot command, despite the RUN/STOP bit being high.

Activate hardware standby mode by forcing the $\overline{\text{STBY}}$ pin low. In a notebook computer, this line may be connected to the system SUSTAT# suspend-state signal.

The $\overline{\text{STBY}}$ pin low state overrides any software conversion command. If a hardware or software standby command is received while a conversion is in progress, the conversion cycle is truncated, and the data from that conversion is not latched into either temperature reading register. The previous data is not changed and remains available.

Supply-current drain during the 125ms conversion period is always about 550 μ A. Slowing down the conversion rate reduces the average supply current (see *Typical Operating Characteristics*). In between conversions, the supply current is about 25 μ A due to the current consumed by the conversion rate timer. In standby mode, supply current drops to about 3 μ A. At very low supply voltages (under the power-on-reset threshold), the supply current is higher due to the address pin bias currents. It can be as high as 100 μ A, depending on ADD0 and ADD1 settings.

SMBus Digital Interface

From a software perspective, the MAX6690 appears as a set of byte-wide registers that contain temperature data, alarm threshold values, or control bits. A standard SMBus 2-wire serial interface is used to read temperature data and write control bits and alarm threshold data. The device responds to the same SMBus slave address for access to all functions.

The MAX6690 employs four standard SMBus protocols: Write Byte, Read Byte, Send Byte, and Receive Byte (Figures 3, 4, 5). The shorter Receive Byte protocol allows quicker transfers, provided that the correct data register was previously selected by a Read Byte instruction. Use caution with the shorter protocols in multimaster systems, since a second master could overwrite the command byte without informing the first master.

2°C Accurate Remote/Local Temperature Sensor with SMBus Serial Interface

Write Byte Format

S	ADDRESS	WR	ACK	COMMAND	ACK	DATA	ACK	P
	7 bits			8 bits		8 bits		1

Slave Address: equivalent to chip-select line of a 3-wire interface

Command Byte: selects which register you are writing to

Data Byte: data goes into the register set by the command byte (to set thresholds, configuration masks, and sampling rate)

Read Byte Format

S	ADDRESS	WR	ACK	COMMAND	ACK	S	ADDRESS	RD	ACK	DATA	///	P
	7 bits			8 bits			7 bits			8 bits		

Slave Address: equivalent to chip-select line

Command Byte: selects which register you are reading from

Slave Address: repeated due to change in data-flow direction

Data Byte: reads from the register set by the command byte

Send Byte Format

S	ADDRESS	WR	ACK	COMMAND	ACK	P
	7 bits			8 bits		

Command Byte: sends command with no data, usually used for one-shot command

Receive Byte Format

S	ADDRESS	RD	ACK	DATA	///	P
	7 bits			8 bits		

Data Byte: reads data from the register commanded by the last Read Byte or Write Byte transmission; also used for SMBus Alert Response return address

S = Start condition Shaded = Slave transmission
P = Stop condition /// = Not acknowledged

Figure 3. SMBus Protocols

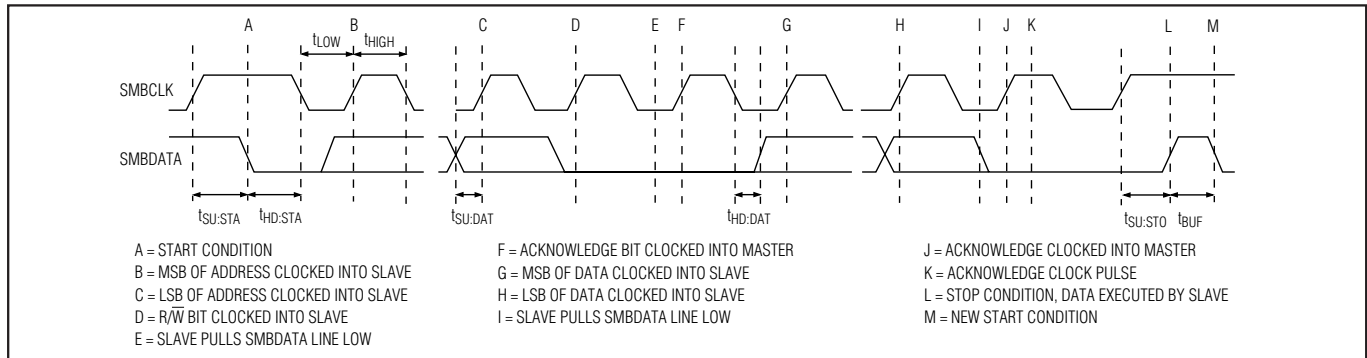

Figure 4. SMBus Write Timing Diagram

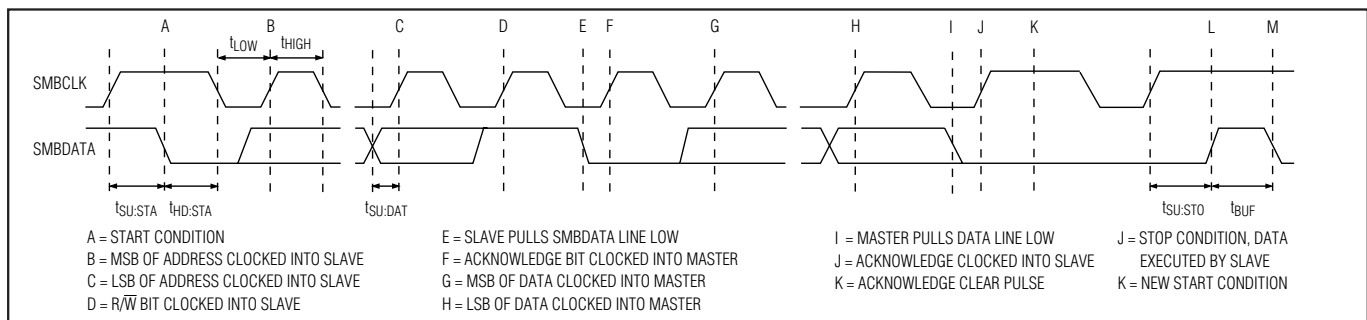

Figure 5. SMBus Read Timing Diagram

2°C Accurate Remote/Local Temperature Sensor with SMBus Serial Interface

Table 2. Data Format

TEMP (°C)	ROUNDED TEMP (°C)	DIGITAL OUTPUT
130.00	+127	0 111 1111
127.00	+127	0 111 1111
126.00	+127	0 111 1111
25.25	+25	0 001 1001
0.50	+1	0 000 0001
0.00	0	0 000 0000
<0.00 (Note 1)	(Normal mode)	1 000 0000
-1	(Extended temp mode)	1 111 1111
<-64	(Extended temp mode)	1 000 0000
Diode fault (short or open)		1 000 0000

Table 3. Extended Resolution Register

FRACTIONAL TEMPERATURE	DIGITAL OUTPUT
0.000	000X XXXX
0.125	001X XXXX
0.250	010X XXXX
0.375	011X XXXX
0.500	100X XXXX
0.625	101X XXXX
0.750	110X XXXX
0.875	111X XXXX

When the conversion rate is greater than 1Hz, temperature data can be read from the read internal temperature (00h) and read external temperature (01h) registers. The temperature data format is 7 bits plus sign in two's-complement form for each channel, with the LSB representing 1°C (Table 2), transmitted MSB first. When the conversion rate is less than 1Hz, the extended data can be read from the read external extended temperature register (10h) and the read internal extended temperature register (11h), and the first 3 bits of the register represent 1/2, 1/4, and 1/8 of a degree. Measurements are offset by +1/2°C to minimize quantization errors; for example, +99.6°C is reported as +100°C.

When the conversion rate is 1Hz or less, the first 8 bits of temperature data can be read from the read internal temperature (00h) and read external temperature (01h) registers, the same as for faster conversion rates. An additional 3 bits can be read from the read external

extended temperature and read internal extended temperature registers, which extend the resolution to 0.125°C per LSB (Table 3).

If a conversion ends after reading the main register but before reading the extended register, the extended register contains the 3LSBs from the new conversion while the main register contains the 8MSBs from the previous conversion. The extended data in this case is meaningless. To avoid this problem, read extended resolution temperature data using one of the following approaches:

- 1) Put the MAX6690 into standby mode by setting bit 6 of the configuration register to 1. Initiate a one-shot conversion using Command Byte 0Fh. When this conversion is complete, read the contents of the temperature data registers.
- 2) If the MAX6690 is in run mode and the conversion rate is not set to either 1Hz or 8Hz, read the Status Byte. If the BUSY bit indicates that a conversion is in progress, wait until the conversion is complete as indicated by the BUSY bit. Then immediately read the contents of the temperature data registers. If no conversion is in progress, the data can be read within a few μ s, which is a sufficiently short period to ensure that a new conversion can't be completed until after the data has been read.

Note: Extended resolution applies only for conversion speeds of 1Hz and below.

Alarm Threshold Registers

Four registers store alarm threshold data, with high-temperature (T_{HIGH}) and low-temperature (T_{LOW}) registers for each A/D channel. If either measured temperature equals or exceeds the corresponding alarm threshold value, an **ALERT** interrupt is asserted.

The POR state of both T_{HIGH} registers is full scale (0111 1111, or +127°C). The POR state of both T_{LOW} registers is 1100 1001 or -55°C.

Diode Fault Alarm

There is a continuity fault detector at DXP that detects whether the remote diode has an open-circuit condition or if DXP is shorted to DXN, GND, or V_{CC}. If an open circuit exists, then the temperature register is loaded with 1000 0000, and bit 3 of the status register is set to 1 at the end of a conversion. This means that immediately after POR, the status byte indicates no fault is present until the end of the first conversion.

2°C Accurate Remote/Local Temperature Sensor with SMBus Serial Interface

Table 4. Read Format for Alert Response Address (0001100)

BIT	NAME	FUNCTION
7 (MSB)	ADD7	Provide the current MAX6690 slave address that was latched at POR (Table 9)
6	ADD6	
5	ADD5	
4	ADD4	
3	ADD3	
2	ADD2	
1	ADD1	
0 (LSB)	1	Logic 1

Alert Interrupts

The $\overline{\text{ALERT}}$ interrupt output signal is latched and can only be cleared by either reading the status register or by receiving an Alert Response address, if the fault condition has ceased. Interrupts are generated in response to T_{HIGH} and T_{LOW} comparisons and when the remote diode is disconnected (for continuity fault detection). The interrupt does not halt automatic conversions; new temperature data continues to be available over the SMBus interface after $\overline{\text{ALERT}}$ is asserted. The interrupt output pin is open drain so that multiple devices can share a common interrupt line. The interrupt rate can never exceed the conversion rate.

The MAX6690 responds to the SMBus Alert Response address, an interrupt pointer return-address feature (see *Alert Response Address* section). Prior to taking corrective action, always check to ensure that an interrupt is valid by reading the current temperature.

Alert Response Address

The SMBus Alert Response interrupt pointer provides quick fault identification for simple slave devices that lack the complex, expensive logic needed to be a bus master. Upon receiving an $\overline{\text{ALERT}}$ interrupt signal, the host master can broadcast a Receive Byte transmission to the Alert Response slave address (0001 100). Then any slave device that generated an interrupt attempts to identify itself by putting its own address on the bus (Table 4).

The Alert Response can activate several different slave devices simultaneously, similar to the I²C General Call. If more than one slave attempts to respond, bus arbitration rules apply, and the device with the lower address code wins. The losing device does not generate an acknowledge and continues to hold the $\overline{\text{ALERT}}$ line low

until cleared. (The conditions for clearing an $\overline{\text{ALERT}}$ vary depending on the type of slave device. Successful reading of the alert response address clears the interrupt latch provided that the condition that caused the $\overline{\text{ALERT}}$ has already ceased. The $\overline{\text{ALERT}}$ is cleared after the slave address has been returned to the host.)

Command Byte Functions

The 8-bit command byte register (Table 5) is the master index that points to the various other registers within the MAX6690. The register's POR state is 0000 0000, so that a Receive Byte transmission (a protocol that lacks the command byte) that occurs immediately after POR returns the current local temperature data. The one-shot command immediately forces a new conversion cycle to begin. If the one-shot command is received when the MAX6690 is in software standby mode (RUN/STOP bit = high), a new conversion is begun, after which the device returns to standby mode. If a conversion is in progress when a one-shot command is received, the command is ignored. If a one-shot command is received in autoconvert mode (RUN/STOP bit = low) between conversions, a new conversion begins, the conversion rate timer is reset, and the next automatic conversion takes place after a full delay elapses.

Configuration Byte Functions

The configuration byte register (Table 6) is a read-write register with several functions. Bit 7 is used to mask (disable) interrupts. Bit 6 puts the MAX6690 into software standby mode (STOP) or autoconvert (RUN) mode. Bit 5 selects the extended temperature range mode, which allows temperature data to be read down to -65°C. Bit 4 puts the MAX6690 into parasitic resistance cancellation mode (PRCM), which can reduce temperature measurement errors due to resistance in series with the sensing junction. Bit 3 should always be set to zero (default value). Bits 2, 1, and 0 are internally set to zero.

Parasitic Resistance Cancellation Mode

Resistance in series with the remote-sensing junction causes conversion errors on the order of 0.5°C per ohm. The MAX6690 can cancel the effect of parasitic series resistance by using the PRCM. If bit 4 of the configuration byte is set HIGH, then the PRCM is invoked, provided the conversion rate is set $\leq 1\text{Hz}$. If the conversion rate is faster than this, then the setting of bit 4 in the configuration register is ignored. In the PRCM, the conversion time is doubled (to typically 500ms to read both local and remote diodes) but external resistances as high as 100Ω can be compensated.

2°C Accurate Remote/Local Temperature Sensor with SMBus Serial Interface

MAX6690

Table 5. Command-Byte Bit Assignments

REGISTER	ADDRESS	POR STATE	FUNCTION
RLTS	00h	0000 0000	Read Internal Temperature
RRTE	01h	0000 0000	Read External Temperature
RSL	02h	0000 0000	Read Status Byte
RCL	03h	0000 0000	Read Configuration Byte
RCRA	04h	0000 0010	Read Conversion Rate Byte
RLHN	05h	0111 1111	Read Internal High Limit
RLLI	06h	1100 1001	Read Internal Low Limit
RRHI	07h	0111 1111	Read External High Limit
RRLS	08h	1100 1001	Read External Low Limit
WCA	09h	N/A	Write Configuration Byte
WCRW	0Ah	N/A	Write Conversion Rate Byte
WLHO	0Bh	N/A	Write Internal High Limit
WLLM	0Ch	N/A	Write Internal Low Limit
WRHA	0Dh	N/A	Write External High Limit
WRLN	0Eh	N/A	Write External Low Limit
OSHT	0Fh	N/A	One-Shot
RRET	10h	0000 0000	Read External Extended Temperature
RLET	11h	0000 0000	Read Internal Extended Temperature
N/A	FEh	4D	Read Device ID
N/A	FFh	9	Read Device Revision

Table 6. Configuration-Byte Bit Assignments

BIT	NAME	POR STATE	FUNCTION
7 (MSB)	MASK1	0	Masks $\overline{\text{ALERT}}$ interrupts if high.
6	RUN/STOP	0	Standby mode control bit; if high, standby mode is initiated.
5	ETA	0	If high, lower temperature range is extended from 0°C to -64°C.
4	PRCM	0	If high, parasitic resistance cancellation mode is enabled.
3	SPNP	0	—
2 to 0	RFU	0	Reserved.

Status Byte Functions

The status byte register (Table 7) indicates which (if any) temperature thresholds have been exceeded. This byte also indicates whether the ADC is converting and whether there is an open circuit in the remote-diode DXP–DXN path. After POR, the normal state of all the flag bits is zero, assuming none of the alarm conditions are present. The status byte is cleared by any successful read of the status byte, unless the fault persists. Note that the $\overline{\text{ALERT}}$ interrupt latch is not automatically cleared when the status flag bit indicating the $\overline{\text{ALERT}}$ is

cleared. The fault condition must be eliminated before the $\overline{\text{ALERT}}$ can be cleared.

When reading the status byte, check for internal bus collisions caused by asynchronous ADC timing, or else disable the ADC prior to reading the status byte (through the RUN/STOP bit in the configuration byte). In one-shot mode, read the status byte only after the conversion is complete, which is 150ms max after the one-shot conversion is commanded.

2°C Accurate Remote/Local Temperature Sensor with SMBus Serial Interface

Table 7. Status Byte Bit Assignments

BIT	NAME	POR STATE	FUNCTION
7 (MSB)	BUSY	0	ADC is busy converting when high.
6	LHIGH	0	Internal high-temperature alarm has tripped when high; cleared by POR or readout of the entire status byte if the fault condition no longer exists.
5	LLOW	0	Internal low-temperature alarm has tripped when high; cleared by POR or readout of the entire status byte if the fault condition no longer exists.
4	RHIGH	0	External high-temperature alarm has tripped when high; cleared by POR or readout of the entire status byte if the fault condition no longer exists.
3	RLOW	0	External low-temperature alarm has tripped when high; cleared by POR or readout of the entire status byte if the fault condition no longer exists.
2	OPEN	0	A high indicates an external diode is open; cleared by POR or readout of the entire status byte if the fault condition no longer exists.
1 or 0	RFU	0	Reserved.

The MAX6690 incorporates collision avoidance so that completely asynchronous operation is allowed between SMBus operations and temperature conversions.

When autoconverting, if the T_{HIGH} and T_{LOW} limits are close together, it's possible for both high-temp and low-temp status bits to be set, depending on the amount of time between status read operations (especially when converting at the fastest rate). In these circumstances, it is best not to rely on the status bits to indicate reversals in long-term temperature changes. Instead, use a current temperature reading to establish the trend direction.

Conversion Rate Byte

The conversion rate register (Table 8) programs the time interval between conversions in free-running auto-convert mode. This variable rate control can be used to reduce the supply current in portable-equipment applications. The conversion rate byte's POR state is 02h (0.25Hz). The MAX6690 looks only at the 3LSB bits of this register, so the upper 5 bits are "don't care" bits, which should be set to zero. The conversion rate tolerance is $\pm 25\%$ at any rate setting.

Valid A/D conversion results for both channels are available one total conversion time (125ms nominal, 156ms maximum) after initiating a conversion, whether conversion is initiated through the RUN/STOP bit, hardware STBY/pin, one-shot command, or initial power-up.

Extended resolution and the parasitic resistance cancellation mode are available at conversion rates of 1Hz or lower.

Slave Addresses

The MAX6690's device address can be set to one of nine different values by pin strapping ADD0 and ADD1 so that more than one MAX6690 can reside on the same bus without address conflicts (Table 9).

The address pin states are checked at POR only, and the address data stays latched to reduce quiescent supply current due to the bias current needed for high-Z state detection.

The MAX6690 also responds to the SMBus Alert Response slave address (see the *Alert Response Address* section).

POR and UVLO

The MAX6690 has a volatile memory. To prevent ambiguous power-supply conditions from corrupting the data in memory and causing erratic behavior, a POR voltage detector monitors V_{CC} and clears the memory if V_{CC} falls below 2V (typ, see *Electrical Characteristics*). When power is first applied and V_{CC} rises above 2.0V (typ), the logic blocks begin operating, although reads and writes at V_{CC} levels below 3V are not recommended. A second V_{CC} comparator, the ADC undervoltage lockout (UVLO) comparator, prevents the ADC from converting until there is sufficient headroom ($V_{CC} = 2.8V$ typ).

2°C Accurate Remote/Local Temperature Sensor with SMBus Serial Interface

MAX6690

Table 8. Conversion-Rate Control Byte

DATA	CONVERSION RATE (Hz)
00h	0.0625
01h	0.125
02h	0.25
03h	0.5
04h	1
05h	2
06h	4
07h	8
08h-FFh	Reserved

Power-Up Defaults:

- Interrupt latch is cleared.
- Address select pins are sampled.
- ADC begins autoconverting at a 0.25Hz rate.
- Command byte is set to 00h to facilitate quick remote Receive Byte queries.
- T_{HIGH} and T_{LOW} registers are set to max and min limits, respectively.

Chip Information

PROCESS: BiCMOS

Table 9. Slave Address Decoding (ADD0 and ADD1)

ADD0	ADD1	ADDRESS
0	0	0011 000
0	High-Z	0011 001
0	1	0011 010
High-Z	0	0101 001
High-Z	High-Z	0101 010
High-Z	1	0101 011
1	0	1001 100
1	High-Z	1001 101
1	1	1001 110

Note: High-Z means that the pin is left unconnected and floating.

Package Information

For the latest package outline information and land patterns, go to www.maxim-ic.com/packages.

PACKAGE TYPE	PACKAGE CODE	DOCUMENT NO.
16 QSOP	E16-1	21-0055

2°C Accurate Remote/Local Temperature Sensor with SMBus Serial Interface

Revision History

REVISION NUMBER	REVISION DATE	DESCRIPTION	PAGES CHANGED
1	5/06	—	—
2	4/09	Changed device ID in Table 5 to “9” to be consistent with the register content	13

Maxim cannot assume responsibility for use of any circuitry other than circuitry entirely embodied in a Maxim product. No circuit patent licenses are implied. Maxim reserves the right to change the circuitry and specifications without notice at any time.

16 _____ **Maxim Integrated Products, 120 San Gabriel Drive, Sunnyvale, CA 94086 408-737-7600**

Mouser Electronics

Authorized Distributor

Click to View Pricing, Inventory, Delivery & Lifecycle Information:

[Maxim Integrated:](#)

[MAX6690MEE+](#) [MAX6690YMEE+](#) [MAX6690YMEE+T](#) [MAX6690MEE+T](#)