

THIS DRAWING IS UNPUBLISHED. RELEASED FOR PUBLICATION
 © COPYRIGHT - TE Connectivity ALL RIGHTS RESERVED.

REVISIONS					
P	LTR	DESCRIPTION	DATE	DWN	APVD
-	-	SEE SHEET 1	-	-	-

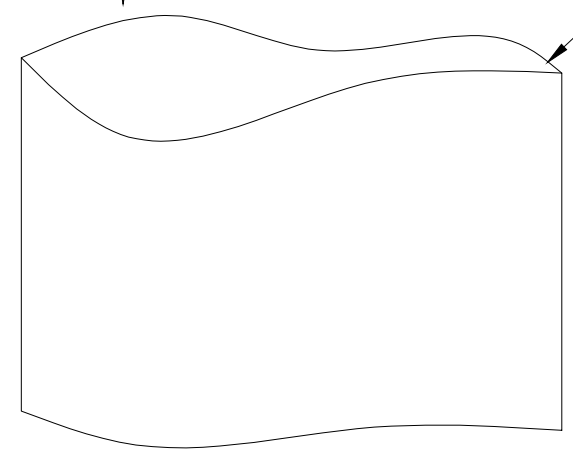

- NOTES :
- MATERIAL :
 TRAY : PS.
 BAG : PE
 BOX : CORRUGATED FIBERBOARD.
 - DIMENSION :
 TRAY : L=346mm, W=215mm, H=7.5mm
 BAG : L=600mm, W=550mm, THICKNESS=0.1mm
 BOX : L=356mm, W=225mm, H=292mm
 - EACH BAG SHALL BE INCLUDED:
 * DESICCANT

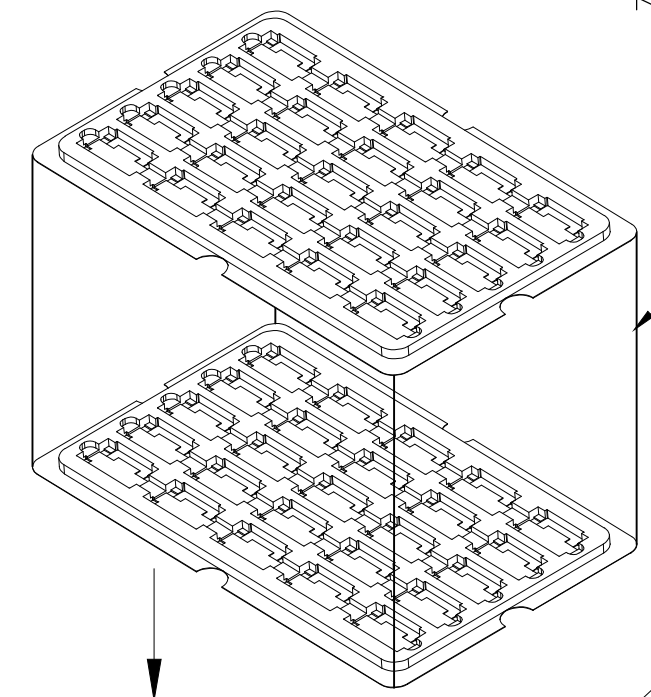
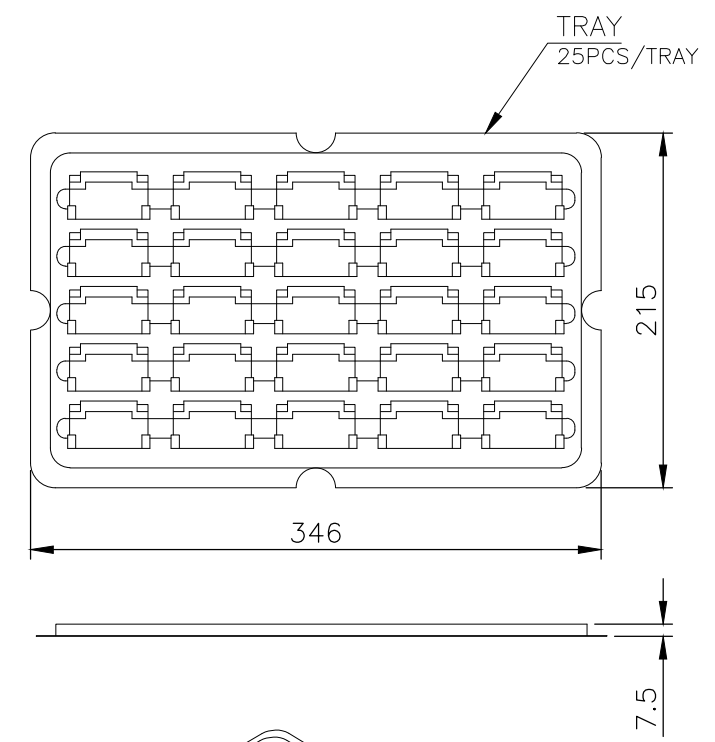
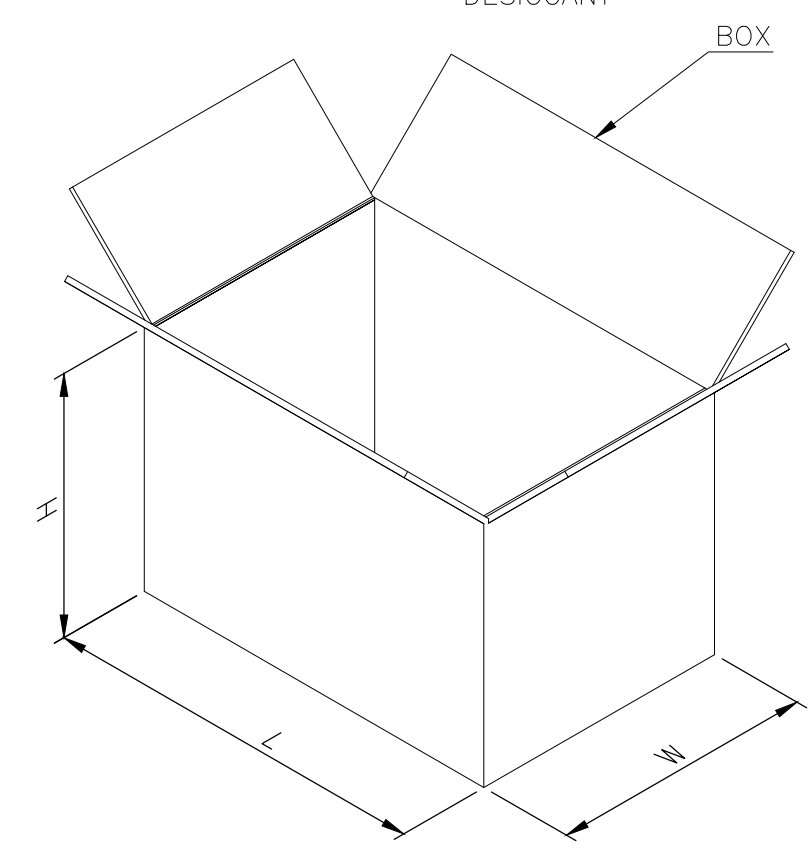

5.45 Kg	2.51 Kg	25	40	1000	1-1734451-1
					1734451-1
GROSS WEIGHT	NET WEIGHT	PCS/TRAY	TRAY/BOX	PCS/BOX	PART NUMBER

THIS DRAWING IS A CONTROLLED DOCUMENT.		DWN S.CHIENT 21JAN2017	STE TE Connectivity		
DIMENSIONS: mm		CHK S.HOU 21JAN2017			
TOLERANCES UNLESS OTHERWISE SPECIFIED:		APVD W.KODAWA 21JAN2017	NAME		
0 PLC ± -		PRODUCT SPEC	COMPACT FLASH CARD CONNECTOR		
1 PLC ± 0.3		108-57134	HEADER ASSEMBLY, 50 POS		
2 PLC ± 0.2		APPLICATION SPEC	TOP MOUNT, SMT TYPE, H=4.0mm		
3 PLC ± 0.15		-	SIZE	CAGE CODE	DRAWING NO
4 PLC ± -		WEIGHT 2.52 GRAMS	A3	00779	C=1734451
ANGLES ± 3°		CUSTOMER DRAWING	RESTRICTED TO	-	
MATERIAL SEE NOTE		FINISH SEE NOTE	SCALE 1:1	SHEET 2 OF 3	REV F

THIS DRAWING IS UNPUBLISHED. RELEASED FOR PUBLICATION
 © COPYRIGHT - TE Connectivity ALL RIGHTS RESERVED.

REVISIONS					
P	LTR	DESCRIPTION	DATE	DWN	APVD
-	-	SEE SHEET 1	-	-	-

TAPE AND REEL PACKING : AS SHOWN

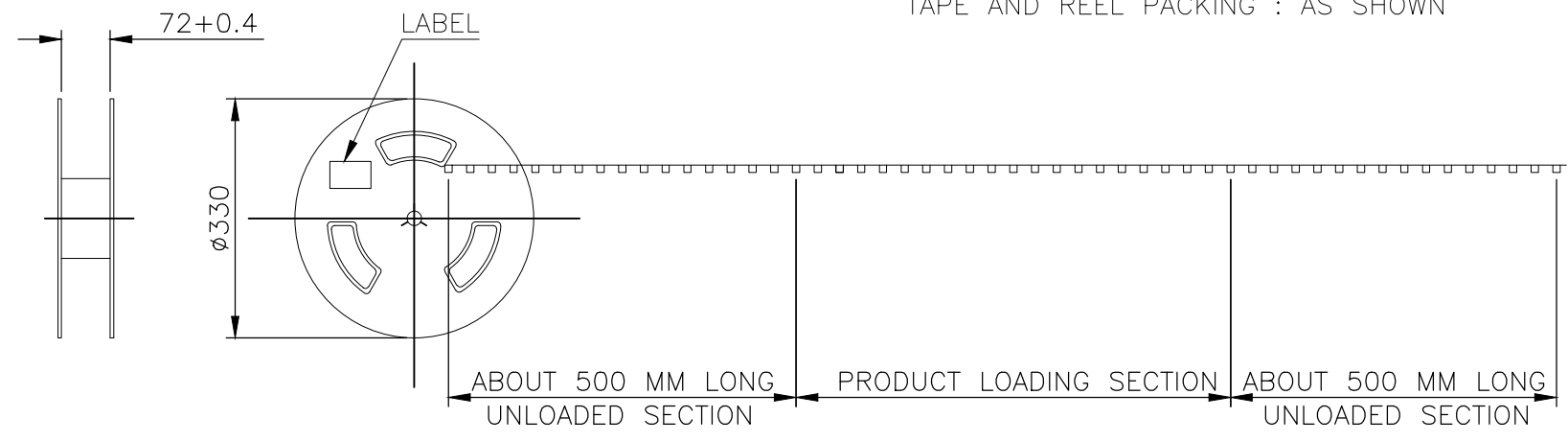

NOTES:

- MATERIAL:
 REEL: PS.
 BAG: PE
 BOX: CORRUGATED FIBERBOARD
- DIMENSION:
 REEL: $\phi 330 \times 72$
 BAG: L=850mm, W=600mm, THICKNESS=0.1mm
 BOX: L=350mm, W=350mm, H=400mm
- EACH BAG SHALL BE INCLUDED:
 * DESICCANT
- QUANTITY: SEE TABLE
- WEIGHT: SEE TABLE

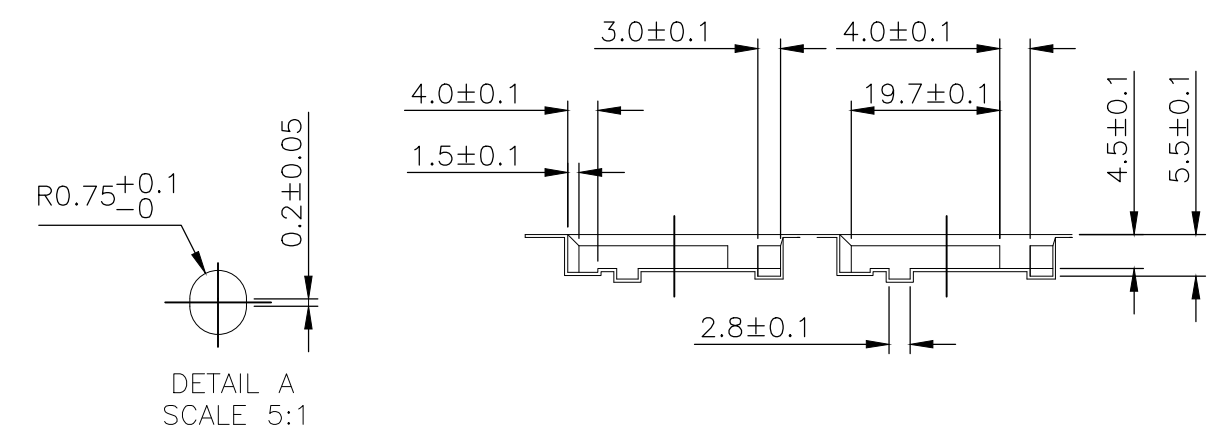
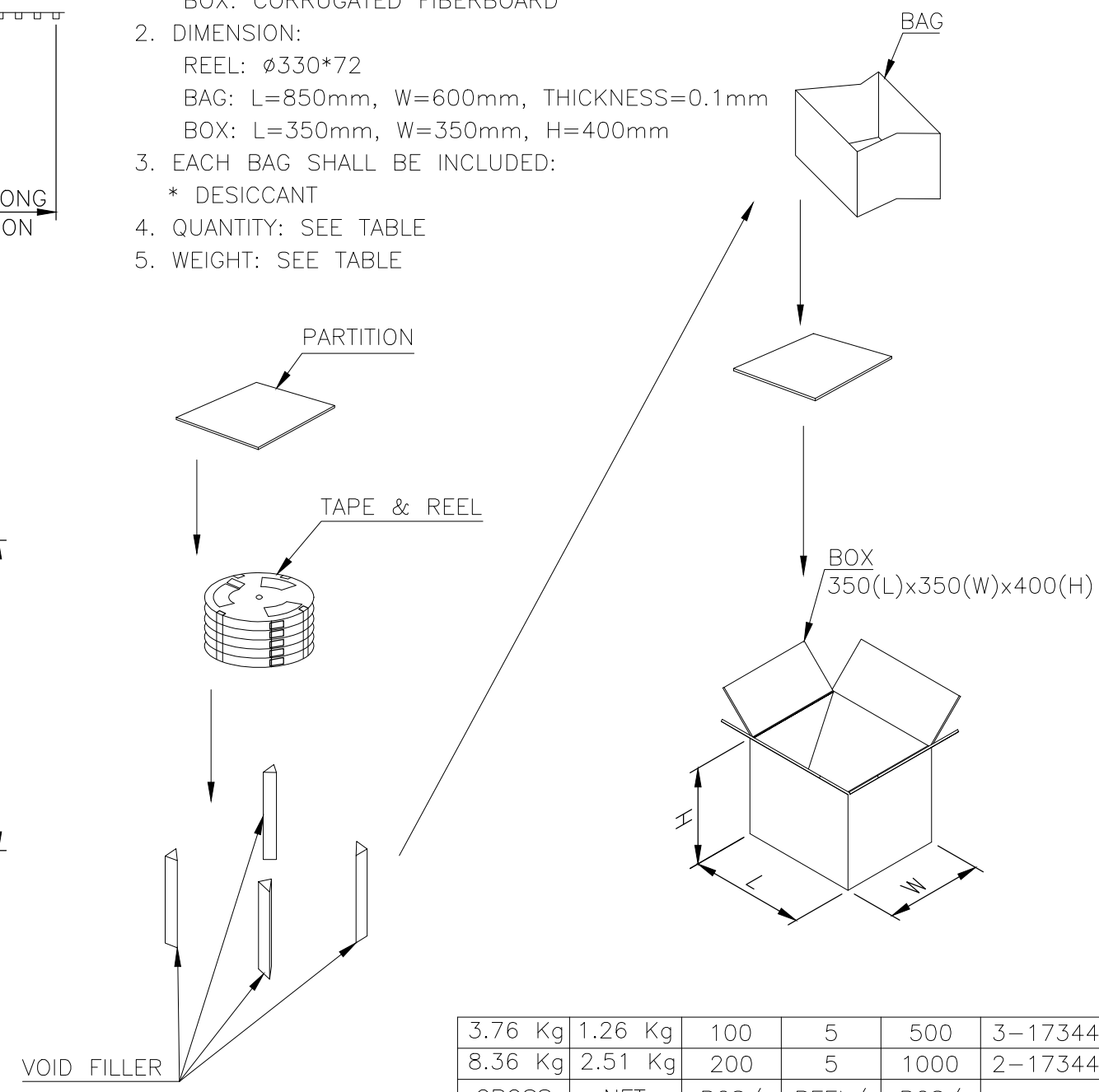
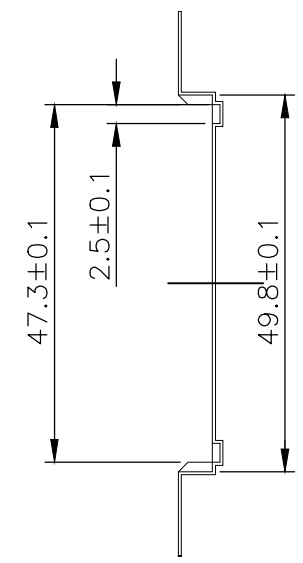
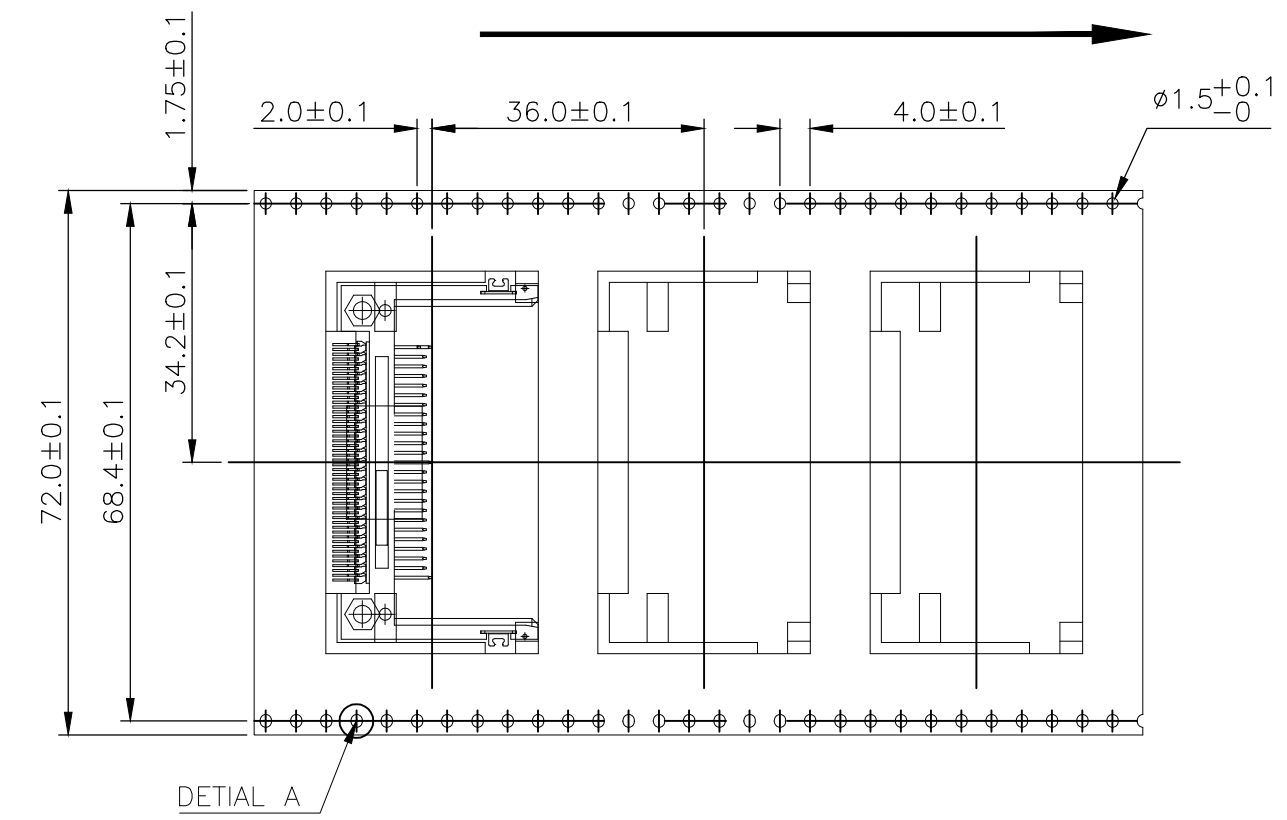

GROSS WEIGHT	NET WEIGHT	PCS/ REEL	REEL/ BOX	PCS/ BOX	PART NUMBER
3.76 Kg	1.26 Kg	100	5	500	3-1734451-1
8.36 Kg	2.51 Kg	200	5	1000	2-1734451-1

THIS DRAWING IS A CONTROLLED DOCUMENT.		DWN S.CH IEN 21JAN2017	TE Connectivity		
DIMENSIONS: mm		CHK S.HOU 21JAN2017			
TOLERANCES UNLESS OTHERWISE SPECIFIED:		APVD W.KODAWA 21JAN2017	NAME		
0 PLC ± -		PRODUCT SPEC	COMPACT FLASH CARD CONNECTOR		
1 PLC ± 0.3		108-57134	HEADER ASSEMBLY, 50 POS		
2 PLC ± 0.2		APPLICATION SPEC	TOP MOUNT, SMT TYPE, H=4.0mm		
3 PLC ± 0.15		-	SIZE	CAGE CODE	DRAWING NO
4 PLC ± -		WEIGHT 2.52 GRAMS	A3	00779	C=1734451
ANGLES ± 3'		CUSTOMER DRAWING	RESTRICTED TO	-	
FINISH SEE NOTE		SCALE 1:1	SHEET 3 OF 3	REV F	

Mouser Electronics

Authorized Distributor

Click to View Pricing, Inventory, Delivery & Lifecycle Information:

[TE Connectivity:](#)

[1734451-1](#)