

Block Diagram

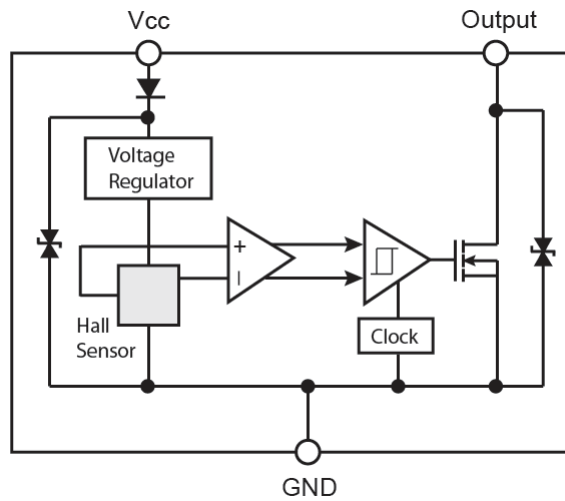

Typical Application Circuit

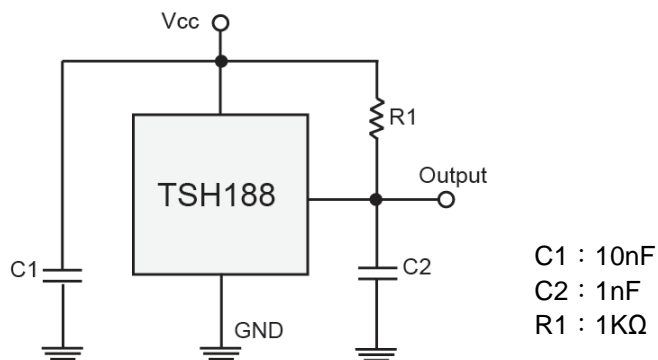

Electrical Specifications (DC Operating Parameters : $T_A=+25^{\circ}\text{C}, V_{CC}=12\text{V}$)

Parameters	Test Conditions	Min	Typ	Max	Units
Supply Voltage	Operating	2.5	--	24	V
Supply Current	$B < B_{OP}$	--	--	5	mA
Output Saturation Voltage	$I_{OUT}=20\text{mA}, B > B_{OP}$	--	--	400	mV
Output Leakage Current	$I_{OFF} B < B_{RP}, V_{OUT} = 12\text{V}$	--	--	10	uA
Internal Oscillator Chopper Frequency		--	69	--	kHz
Output Rise Time	$R_L=1.1\text{K}\Omega, C_L=20\text{pF}$	--	0.04	0.45	uS
Output Fall Time	$R_L=820\Omega; C_L=20\text{pF}$	--	0.18	0.45	uS
ESD	HBM	4	--	--	KV
Operate Point		5(-25)	--	25(-5)	Gauss
Release Point		-25(5)	--	-5(25)	Gauss
Hysteresis		--	30	--	Gauss

Note: 1G (Gauss) = 0.1mT (millitesta)

Output Behavior versus Magnetic Pole

DC Operating Parameters: $T_A = -40$ to 125°C , $V_{CC} = 2.5\text{--}24\text{V}$

Parameter	Test condition	OUT (TO-92S)	OUT (SOT-23)
North pole	$B > B_{OP}$	Open(Hi)	Low
South pole	$B < B_{RP}$	Low	Open(Hi)

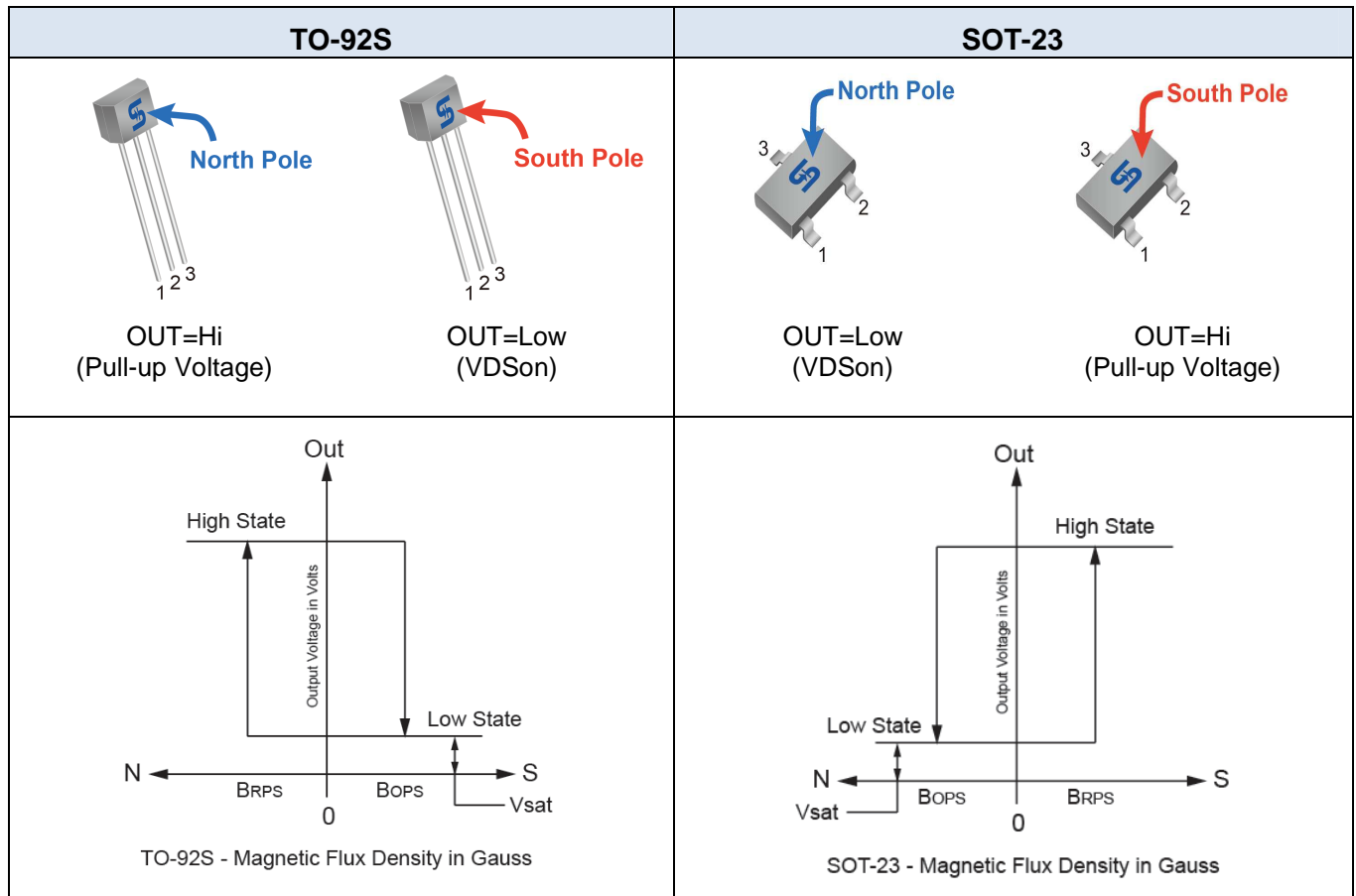

Characteristic Performance

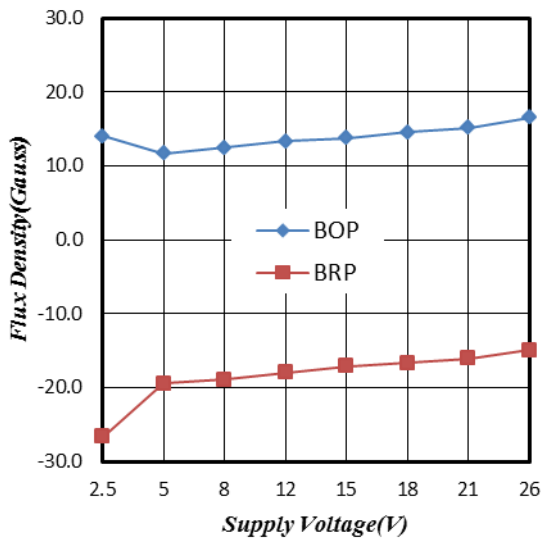

Figure 1. Supply Voltage vs. Flux Density

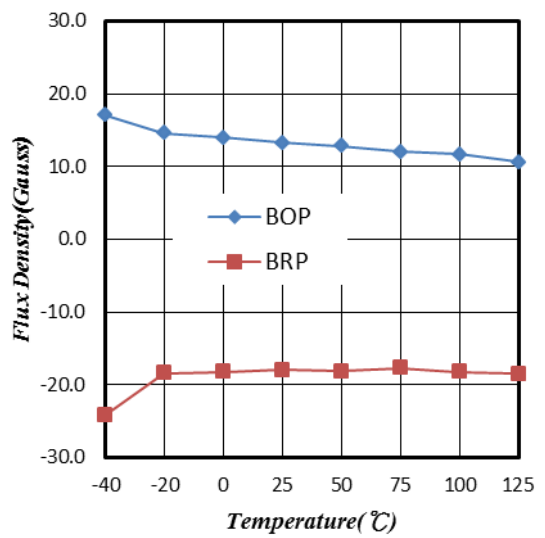

Figure 2. Temperature vs. Flux Density

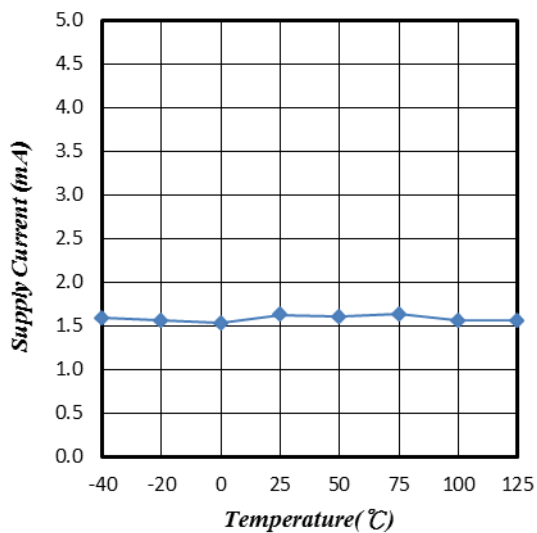

Figure 3. Supply Current vs. Temperature

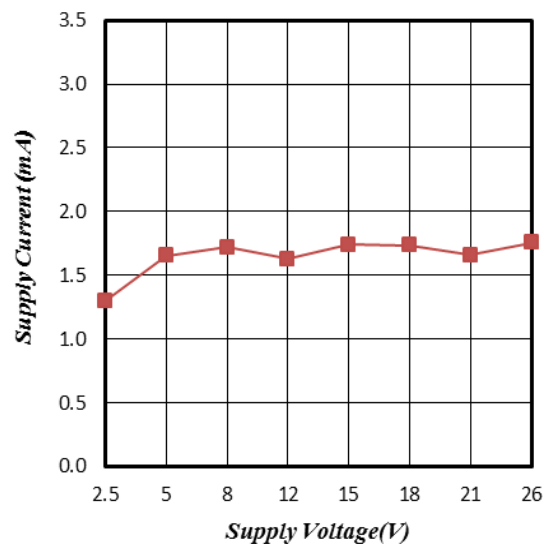

Figure 4. Supply Current vs. Supply Voltage

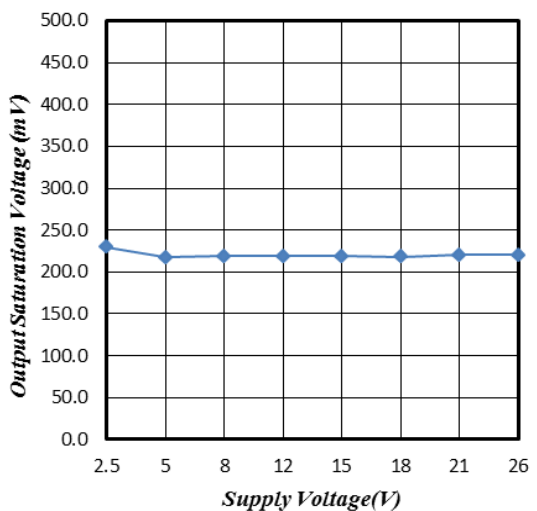

Figure 5. Supply Voltage vs. Saturation Voltage

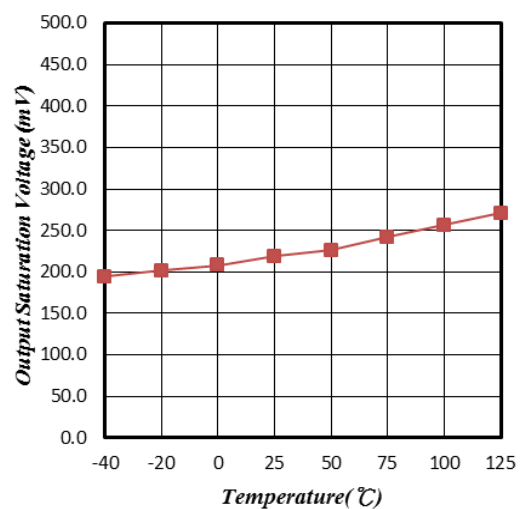

Figure 6. Saturation Voltage vs. Temperature

Characteristic Performance

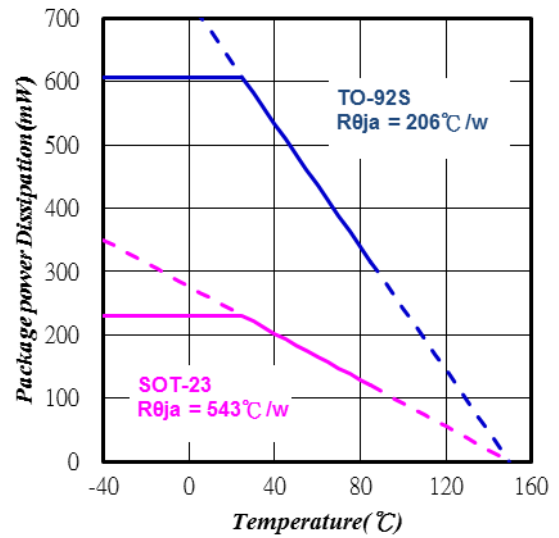
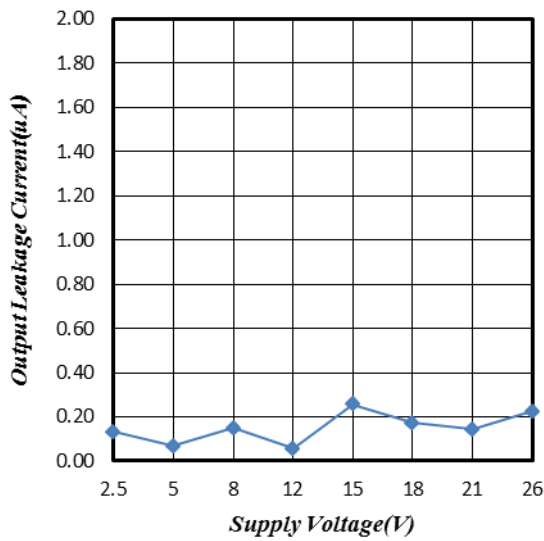

Figure 7. Supply Voltage vs. Leakage Current

Figure 8. Temperature vs. Power Dissipation

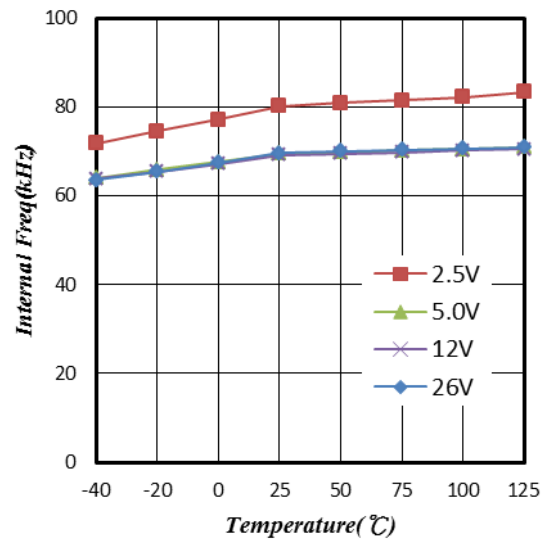
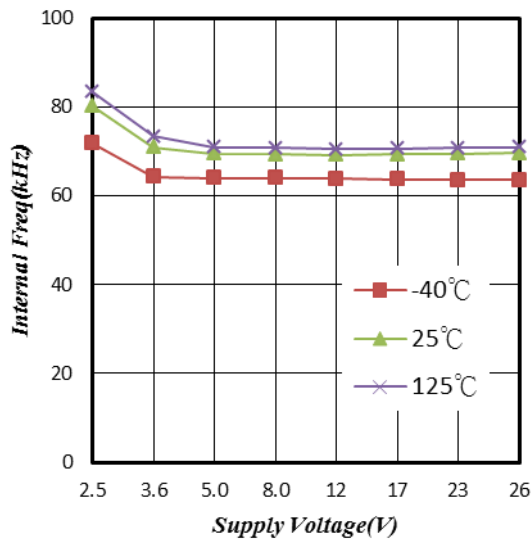
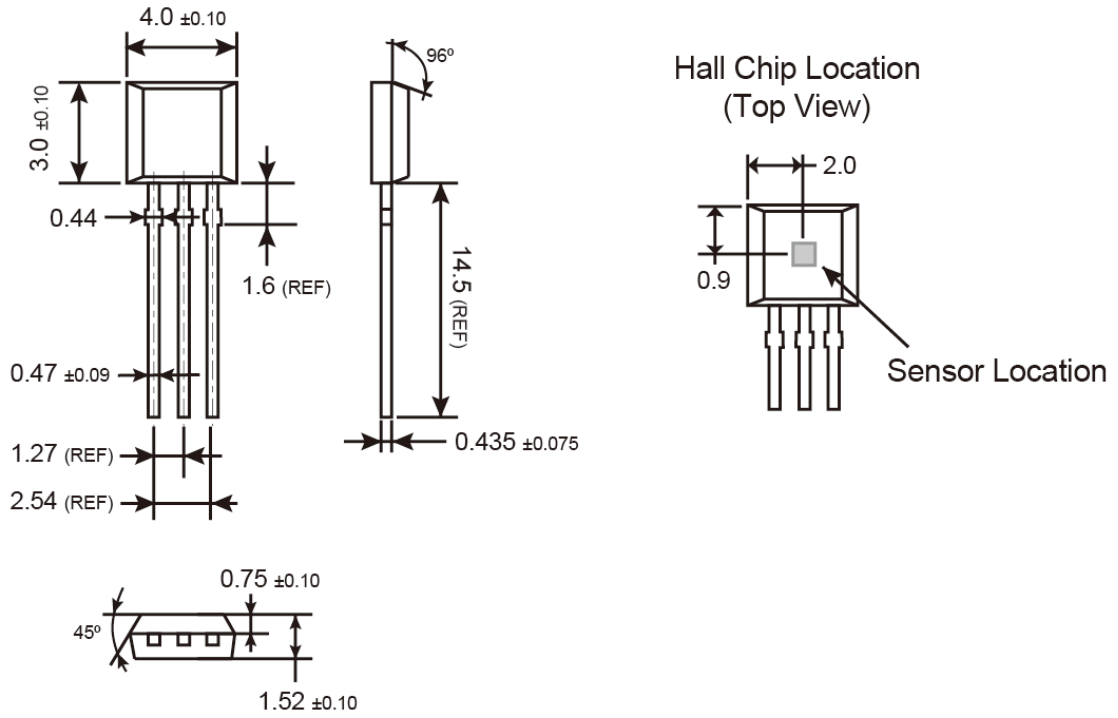

Figure 9. Supply Voltage vs. Internal Frequency

Figure 10. Temperature vs. Internal Frequency

TO-92S Mechanical Drawing



Unit: Millimeters

Marking Diagram

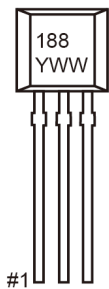

- 188** = Device Code
- Y** = Year Code
- WW** = Week Code (01~52)

SOT-23 Mechanical Drawing

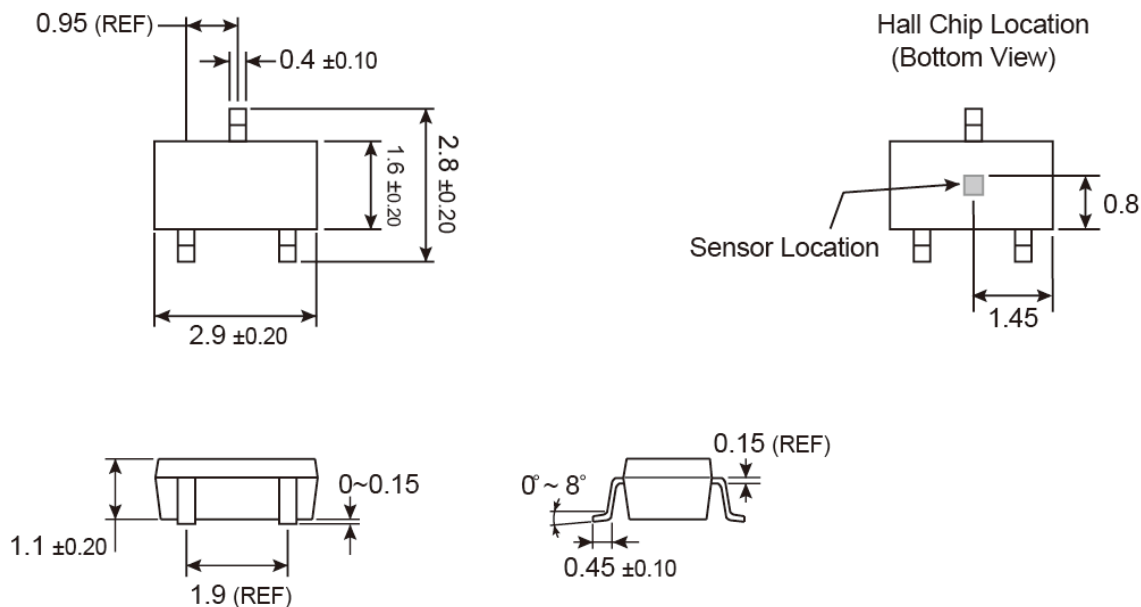

Unit: Millimeters

Marking Diagram

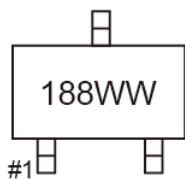

188 = Device Code
WW = Week Code Table

week	1	2	3	4	5	6	7	8	9	10	11	12	13
code	OA	OB	OC	OD	OE	OF	OG	OH	OI	OJ	OK	OL	OM
week	14	15	16	17	18	19	20	21	22	23	24	25	26
code	ON	OO	OP	OQ	OR	OS	OT	OU	OV	OW	OX	OY	OZ
week	27	28	29	30	31	32	33	34	35	36	37	38	39
code	PA	PB	PC	PD	PE	PF	PG	PH	PI	PJ	PK	PL	PM
week	40	41	42	43	44	45	46	47	48	49	50	51	52
code	PN	PO	PP	PQ	PR	PS	PT	PU	PV	PW	PX	PY	PZ

Notice

Specifications of the products displayed herein are subject to change without notice. TSC or anyone on its behalf, assumes no responsibility or liability for any errors or inaccuracies.

Information contained herein is intended to provide a product description only. No license, express or implied, to any intellectual property rights is granted by this document. Except as provided in TSC's terms and conditions of sale for such products, TSC assumes no liability whatsoever, and disclaims any express or implied warranty, relating to sale and/or use of TSC products including liability or warranties relating to fitness for a particular purpose, merchantability, or infringement of any patent, copyright, or other intellectual property right.

The products shown herein are not designed for use in medical, life-saving, or life-sustaining applications. Customers using or selling these products for use in such applications do so at their own risk and agree to fully indemnify TSC for any damages resulting from such improper use or sale.

Mouser Electronics

Authorized Distributor

Click to View Pricing, Inventory, Delivery & Lifecycle Information:

[Taiwan Semiconductor:](#)

[TSH188CX](#) [TSH188CT B0G](#) [TSH188CX RFG](#)