

## DSN9H Series

Part Number	Capacitance (pF)	Rated Voltage (Vdc)	Rated Current (A)	Operating Temperature Range (°C)
DSN9HB32E220	22 +20%,-20%	250	6	-40 to +105
DSN9HB32E101	100 +20%,-20%	250	6	-40 to +105
DSN9HB32E271	270 +20%,-20%	250	6	-40 to +105
DSN9HB32E222	2200 +20%,-20%	250	6	-40 to +105

Please refer to Part Numbering for Type and Length of Lead.

### ■ Equivalent Circuit

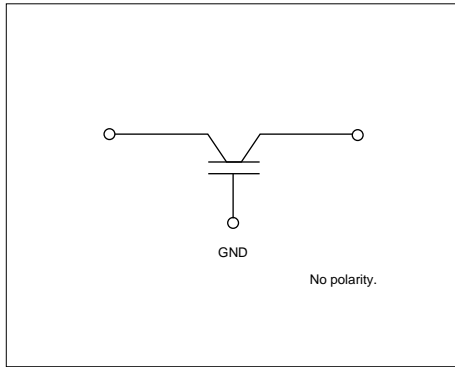

### ■ Insertion Loss Characteristics

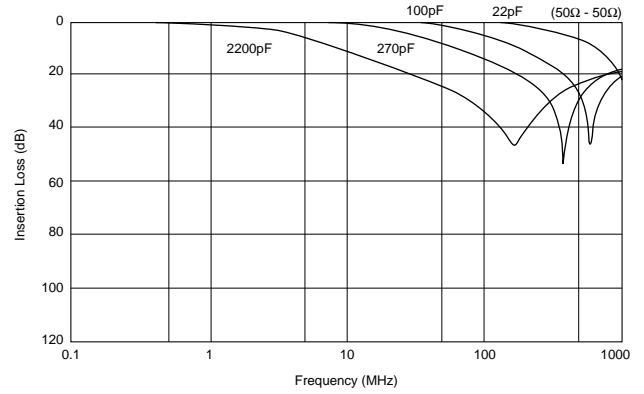

## Built-in Ferrite Beads DSS9H Series

Part Number	Capacitance (pF)	Rated Voltage (Vdc)	Rated Current (A)	Operating Temperature Range (°C)
DSS9HB32E220	22 +20%,-20%	250	6	-40 to +105
DSS9HB32E101	100 +20%,-20%	250	6	-40 to +105
DSS9HB32E271	270 +20%,-20%	250	6	-40 to +105
DSS9HB32E222	2200 +20%,-20%	250	6	-40 to +105

Please refer to Part Numbering for Type and Length of Lead.

### ■ Equivalent Circuit

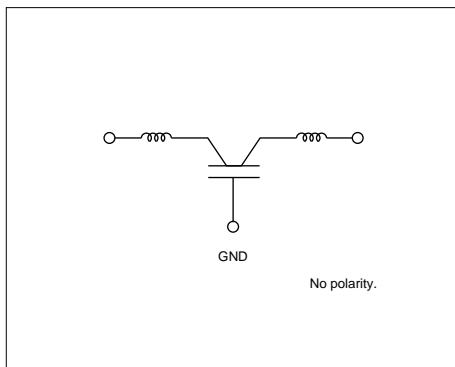

### ■ Insertion Loss Characteristics

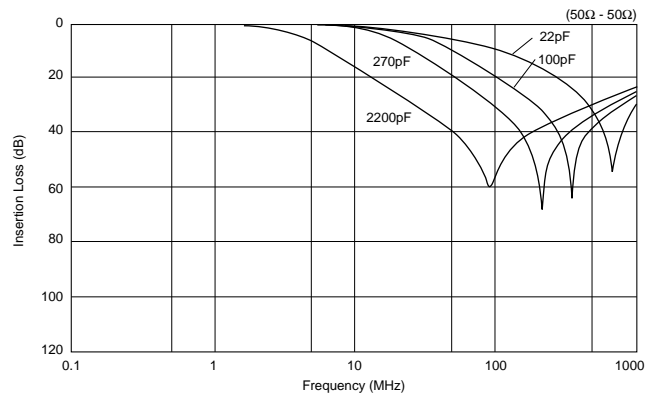

**With Ferrite Beads DST9H Series**

Part Number	Capacitance (pF)	Rated Voltage (Vdc)	Rated Current (A)	Operating Temperature Range (°C)
DST9HB32E220	22 +20%,-20%	250	6	-40 to +105
DST9HB32E101	100 +20%,-20%	250	6	-40 to +105
DST9HB32E271	270 +20%,-20%	250	6	-40 to +105
DST9HB32E222	2200 +20%,-20%	250	6	-40 to +105

Please refer to Part Numbering for Type and Length of Lead.

■ Equivalent Circuit

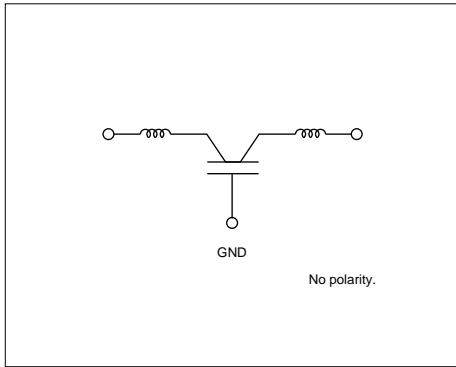

■ Insertion Loss Characteristics

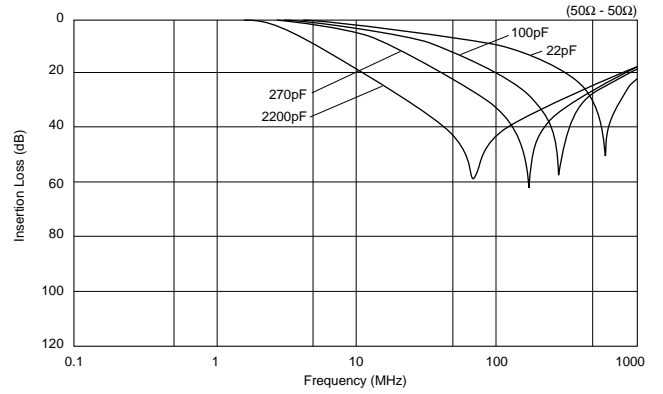

# Mouser Electronics

Authorized Distributor

Click to View Pricing, Inventory, Delivery & Lifecycle Information:

## Murata:

[DSS9HB32E271Q55B](#) [DST9HB32E271Q55B](#) [DSS9HB32E271Q91J](#) [DST9HB32E222Q55B](#) [DSS9HB32E222Q55B](#)  
[DST9HB32E222Q91J](#) [DSS9HB32E222Q91J](#) [DST9HB32E220Q55B](#) [DSS9HB32E220Q55B](#) [DST9HB32E222Q93A](#)  
[DSS9HB32E222Q93J](#) [DSS9HB32E271Q93J](#) [DST9HB32E101Q55B](#) [DSS9HB32E101Q55B](#) [DSS9HB32E101Q93J](#)  
[DSS9HB32E220Q93J](#) [DSS9HB32E222Q54B](#) [DSS9HB32E222Q56B](#) [DST9HB32E101Q93A](#) [DST9HB32E220Q93A](#)  
[DST9HB32E222Q50B](#) [DST9HB32E222Q92A](#) [DST9HB32E271Q92A](#) [DST9HB32E271Q93A](#)