

OPERATION — POWER MONITOR

The DS1815 provides the functions of detecting out-of-tolerance power supply conditions and warning a processor-based system of impending power failure. When V_{CC} is detected as out of tolerance, the \overline{RST} signal is asserted. On power-up, \overline{RST} is kept active for approximately 150ms after the power supply has reached the selected tolerance. This allows the power supply and microprocessor to stabilize before \overline{RST} is released.

BLOCK DIAGRAM (CMOS OUTPUT) Figure 1

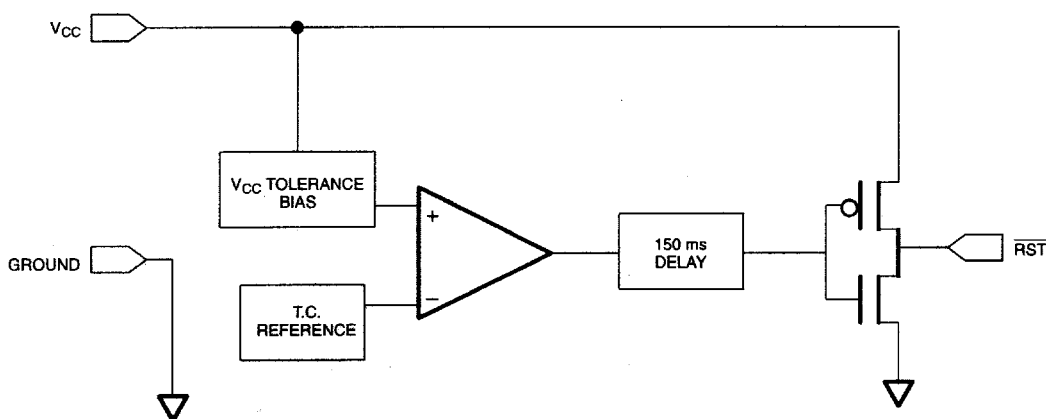

APPLICATION EXAMPLE Figure 2

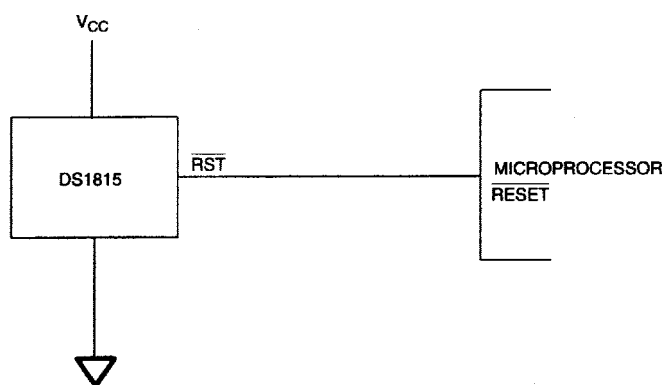

APPLICATION DIAGRAM:

\overline{RST} VALID TO 0 VOLTS V_{CC} ON THE DS1815 Figure 3

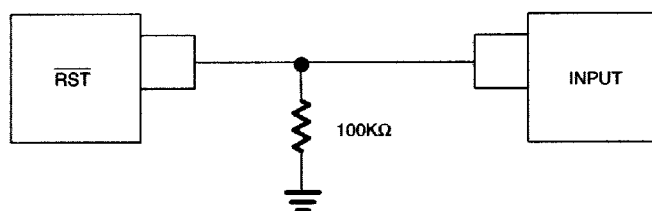

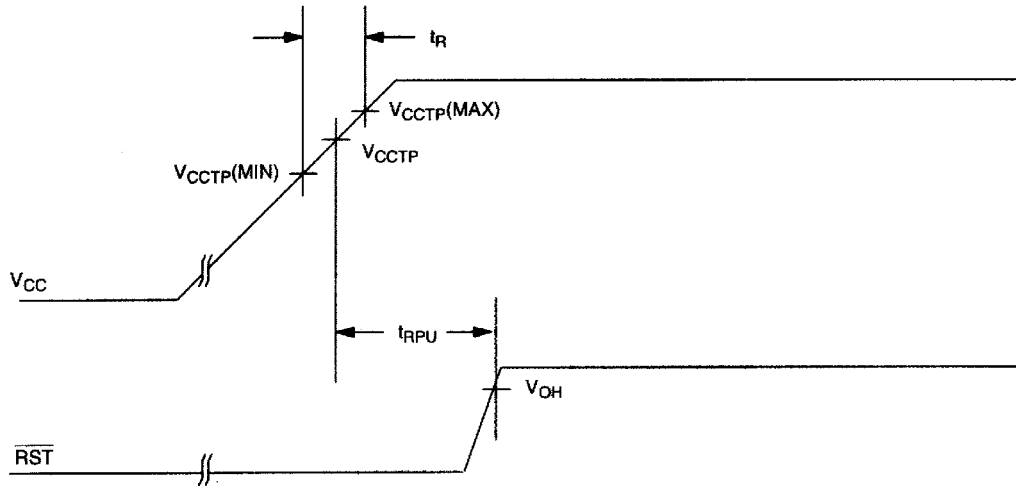
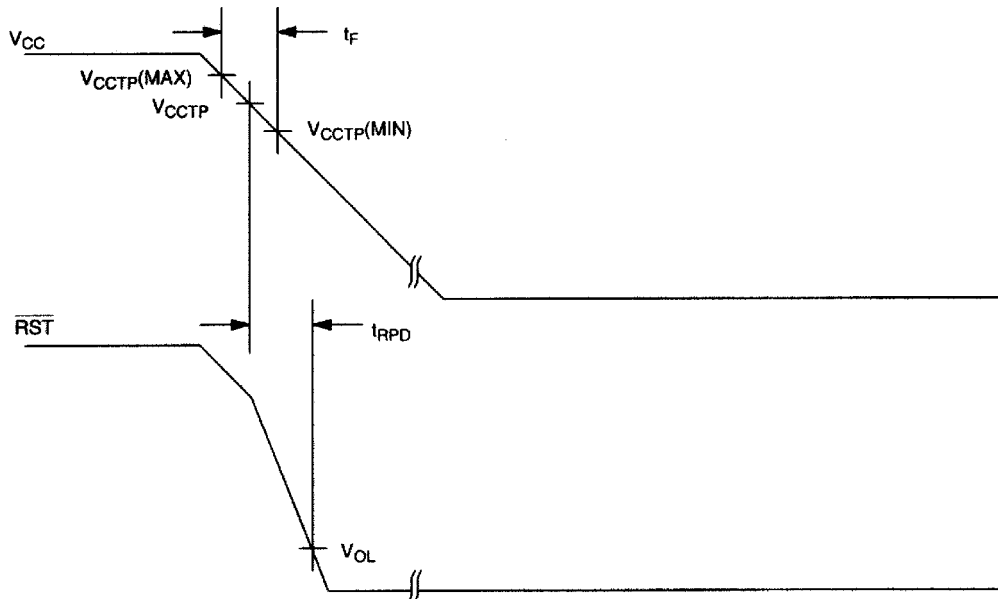
TIMING DIAGRAM: POWER-UP Figure 4**TIMING DIAGRAM: POWER-DOWN** Figure 5

ABSOLUTE MAXIMUM RATINGS*

Voltage on V_{CC} Pin Relative to Ground	-0.5V to +7.0V
Voltage on RST Relative to Ground	-0.5V to +5 V_{CC} +0.5V
Operating Temperature	-40°C to +85°C
Storage Temperature	-55°C to +125°C
Soldering Temperature	260°C for 10 seconds

* This is a stress rating only and functional operation of the device at these or any other conditions above those indicated in the operation sections of this specification is not implied. Exposure to absolute maximum rating conditions for extended periods of time may affect reliability.

RECOMMENDED DC OPERATING CONDITIONS (-40°C to +85°C)

PARAMETER	SYMBOL	MIN	TYP	MAX	UNITS	NOTES
Supply Voltage	V_{CC}	0.0		5.5	V	1

DC ELECTRICAL CHARACTERISTICS (-40°C to +85°C; $V_{CC} = 1.2V$ to 5.5V)

PARAMETER	SYMBOL	MIN	TYP	MAX	UNITS	NOTES
Output Voltage @ -500 μ A	V_{OH}	V_{CC} -0.5V	V_{CC} -0.1V		V	1
Output Current @ 2.4V	I_{OH}		350		μ A	2
Output Current @ 0.4V	I_{OL}	+10			mA	2
Operating Current $V_{CC} < 5.5$	I_{CC}		28	35	μ A	3
V_{CC} Trip Point (DS1815-5)	V_{CCTP}	2.98	3.06	3.15	V	1
V_{CC} Trip Point (DS1815-10)	V_{CCTP}	2.80	2.88	2.97	V	1
V_{CC} Trip Point (DS1815-20)	V_{CCTP}	2.47	2.55	2.64	V	1
Output Capacitance	C_{OUT}			10	pF	

AC ELECTRICAL CHARACTERISTICS (-40°C to +85°C; $V_{CC} = 1.2V$ to 5.5V)

PARAMETER	SYMBOL	MIN	TYP	MAX	UNITS	NOTES
RESET Active Time	t_{RST}	100	150	250	ms	4
V_{CC} Detect to \overline{RST}	t_{RPD}		2	5	μ s	
V_{CC} Slew Rate (V_{CCTP} (MAX) to V_{CCTP} (MIN))	t_F	300			μ s	6
V_{CC} Slew Rate (V_{CCTP} (MIN) to V_{CCTP} (MAX))	t_R	0			ns	
V_{CC} Detect to \overline{RST}	t_{RPU}	100	150	250	ms	4, 5

NOTES:

1. All voltages are referenced to ground.
2. Measured with $V_{CC} \geq 2.7V$.
3. Measured with \overline{RST} output open.
4. Measured with $2.7V \leq V_{CC} \leq 3.3V$.
5. $t_R = 5\mu s$.
6. The t_F value is for reference in defining values for T_{RPD} and should not be considered a requirement for proper operation or use of the device.

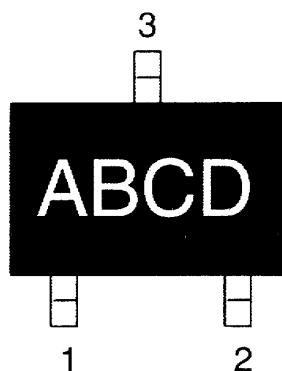
PART MARKING CODES

“A”, “B”, & “C” represent the device type.

810 DS1810
 811 DS1811
 812 DS1812
 813 DS1813
 815 DS1815
 816 DS1816
 817 DS1817
 818 DS1818

“D” represents the device tolerance.

A 5%
 B 10%
 C 15%
 D 20%

Mouser Electronics

Authorized Distributor

Click to View Pricing, Inventory, Delivery & Lifecycle Information:

Maxim Integrated:

[DS1815R-5-U](#) [DS1815R-5/T&R](#) [DS1815-10](#) [DS1815-10/T&R](#) [DS1815-20](#) [DS1815-5](#) [DS1815R-10/T&R](#) [DS1815R-20/T&R](#) [DS1815-5/T&R](#) [DS1815R-10-U](#) [DS1815-20/T&R](#) [DS1815R-20-U](#)