

Single/Dual/Quad, 28MHz, Low-Noise, Low-Voltage, Precision Op Amps

ABSOLUTE MAXIMUM RATINGS

Supply Voltage 12V
 Differential Input Current (Note 1) ±20mA
 Input Voltage Range V+ to V-
 Common-Mode Input Voltage (V+ + 0.3V) to (V- - 0.3V)
 Short-Circuit Current Duration Continuous
 Continuous Power Dissipation (T_A = +70°C)
 MAX410/MAX412
 8-Pin Plastic DIP (derate 9.09mW/°C above +70°C) ...727mW
 8-Pin SO (derate 5.88mW/°C above +70°C).....471mW
 8-Pin TDFN (derate 18.5mW/°C above +70°C)1482mW

MAX414
 14-Pin Plastic DIP (derate 10.00mW/°C above +70°C)800mW
 14-Pin SO (derate 8.33mW/°C above +70°C).....667mW
 Operating Temperature Ranges:
 MAX41_C_ _0°C to +70°C
 MAX41_E_ _-40°C to +85°C
 MAX41_M_ _-55°C to +125°C
 Storage Temperature Range-65°C to +150°C
 Lead Temperature (soldering, 10s)+300°C

Note 1: The amplifier inputs are connected by internal back-to-back clamp diodes. In order to minimize noise in the input stage, current-limiting resistors are not used. If differential input voltages exceeding ±1.0V are applied, limit input current to 20mA.

Stresses beyond those listed under "Absolute Maximum Ratings" may cause permanent damage to the device. These are stress ratings only, and functional operation of the device at these or any other conditions beyond those indicated in the operational sections of the specifications is not implied. Exposure to absolute maximum rating conditions for extended periods may affect device reliability.

ELECTRICAL CHARACTERISTICS

(V+ = 5V, V- = -5V, T_A = +25°C, unless otherwise noted.)

PARAMETER	SYMBOL	CONDITIONS		MIN	TYP	MAX	UNITS
Input Offset Voltage	V _{OS}	MAX410, MAX410B, MAX412, MAX412B		±120	±250		μV
		MAX414, MAX414B		±150	±320		
Input Bias Current	I _B			±80	±150		nA
Input Offset Current	I _{OS}			±40	±80		nA
Differential Input Resistance	R _{IN(Diff)}			20			kΩ
Common-Mode Input Resistance	R _{IN(CM)}			40			MΩ
Input Capacitance	C _{IN}			4			pF
Input Noise-Voltage Density	e _n	MAX410, MAX412, MAX414	10Hz		7		nV√Hz
			1000Hz (Note 2)	1.5	2.4		
		MAX410B, MAX412B, MAX414B	1000Hz (Note 2)	2.4	4.0		
Input Noise-Current Density	i _n	f _O = 10Hz			2.6		pA√Hz
		f _O = 1000Hz			1.2		
Common-Mode Input Voltage	V _{CM}			±3.5	+3.7/ -3.8		V
Common-Mode Rejection Ratio	CMRR	V _{CM} = ±3.5V		115	130		dB
Power-Supply Rejection Ratio	PSRR	V _S = ±2.4V to ±5.25V		96	103		dB
Large-Signal Gain	A _{VOL}	R _L = 2kΩ, V _O = ±3.6V		115	122		dB
		R _L = 600Ω, V _O = ±3.5V		110	120		
Output Voltage Swing	V _{OUT}	R _L = 2kΩ		+3.6 -3.7	+3.7/ -3.8		V
Short-Circuit Output Current	I _{SC}				35		mA
Slew Rate	SR	10kΩ 20pF load			4.5		V/μs
Unity-Gain Bandwidth	GBW	10kΩ 20pF load			28		MHz
Settling Time	t _S	T _O 0.1%			1.3		μs
Channel Separation	C _S	f _O = 1kHz			135		dB

Single/Dual/Quad, 28MHz, Low-Noise, Low-Voltage, Precision Op Amps

MAX410/MAX412/MAX414

ELECTRICAL CHARACTERISTICS (continued)

(V₊ = 5V, V₋ = -5V, T_A = +25°C, unless otherwise noted.)

PARAMETER	SYMBOL	CONDITIONS	MIN	TYP	MAX	UNITS
Operating Supply-Voltage Range	V _S		±2.4		±5.25	V
Supply Current	I _S	Per amplifier		2.5	2.7	mA

ELECTRICAL CHARACTERISTICS

(V₊ = 5V, V₋ = -5V, T_A = 0°C to +70°C, unless otherwise noted.)

PARAMETER	SYMBOL	CONDITIONS	MIN	TYP	MAX	UNITS
Input Offset Voltage	V _{OS}			±150	±350	μV
Offset Voltage Tempco	ΔV _{OS} /ΔT	Over operating temperature range		±1		μV/°C
Input Bias Current	I _B			±100	±200	nA
Input Offset Current	I _{OS}			±80	±150	nA
Common-Mode Input Voltage	V _{CM}		±3.5	+3.7/ -3.8		V
Common-Mode Rejection Ratio	CMRR	V _{CM} = ±3.5V	105	121		dB
Power-Supply Rejection Ratio	PSRR	V _S = ±2.4V to ±5.25V	90	97		dB
Large-Signal Gain	A _{VOL}	R _L = 2kΩ, V _O = ±3.6V	110	120		dB
		R _L = 600Ω, V _O = ±3.5V	90	119		
Output Voltage Swing	V _{OUT}	R _L = 2kΩ	±3.5	+3.7/ -3.6		V
Supply Current	I _S	Per amplifier			3.3	mA

ELECTRICAL CHARACTERISTICS

(V₊ = 5V, V₋ = -5V, T_A = -40°C to +85°C, unless otherwise noted.) (Note 3)

PARAMETER	SYMBOL	CONDITIONS	MIN	TYP	MAX	UNITS
Input Offset Voltage	V _{OS}	MAX410, MAX410B, MAX412, MAX412B		±200	±400	μV
		MAX414, MAX414B		±200	±450	
Offset Voltage Tempco	ΔV _{OS} /ΔT	Over operating temperature range		±1		μV/°C
Input Bias Current	I _B			±130	±350	nA
Input Offset Current	I _{OS}			±100	±200	nA
Common-Mode Input Voltage	V _{CM}		±3.5	+3.7/ -3.6		V
Common-Mode Rejection Ratio	CMRR	V _{CM} = ±3.5V	105	120		dB
Power-Supply Rejection Ratio	PSRR	V _S = ±2.4V to ±5.25V	90	94		dB
Large-Signal Gain	A _{VOL}	R _L = 2kΩ, V _O = ±3.6V	110	118		dB
		R _L = 600Ω, V _O = +3.4V to -3.5V	90	114		
Output Voltage Swing	V _{OUT}	R _L = 2kΩ	±3.5	+3.7/ -3.6		V
Supply Current	I _S	Per amplifier			3.3	mA

Single/Dual/Quad, 28MHz, Low-Noise, Low-Voltage, Precision Op Amps

ELECTRICAL CHARACTERISTICS (MAX410 only)

($V_+ = 5V$, $V_- = -5V$, $T_A = -55^\circ\text{C}$ to $+125^\circ\text{C}$, unless otherwise noted.)

PARAMETER	SYMBOL	CONDITIONS	MIN	TYP	MAX	UNITS
Input Offset Voltage	V_{OS}			± 200	± 400	μV
Offset Voltage Tempco	$\Delta V_{OS}/\Delta T$	Over operating temperature range		± 1		$\mu\text{V}/^\circ\text{C}$
Input Bias Current	I_B			± 130	± 350	nA
Input Offset Current	I_{OS}			± 100	± 200	nA
Common-Mode Input Voltage	V_{CM}		± 3.5	+3.7/ -3.6		V
Common-Mode Rejection Ratio	CMRR	$V_{CM} = \pm 3.5V$	105	120		dB
Power-Supply Rejection Ratio	PSRR	$V_S = \pm 2.4V$ to $\pm 5.25V$	90	94		dB
Large-Signal Gain	A_{VOL}	$R_L = 2k\Omega$, $V_O = \pm 3.5V$	110	118		dB
		$R_L = 600\Omega$, $V_O = +3.4V$ to $-3.5V$	90	114		
Output Voltage Swing	V_{OUT}	$R_L = 2k\Omega$	± 3.5	+3.7/ -3.6		V
Supply Current	I_S	Per amplifier			3.3	mA

Note 2: Guaranteed by design.

Note 3: All TDFN devices are 100% tested at $T_A = +25^\circ\text{C}$. Limits over temperature for thin TDFNs are guaranteed by design.

Single/Dual/Quad, 28MHz, Low-Noise, Low-Voltage, Precision Op Amps

Typical Operating Characteristics

($V_A = \pm 5V$, $V_S = \pm 5V$, $T_A = +25^\circ C$, unless otherwise noted.)

MAX410/MAX412/MAX414

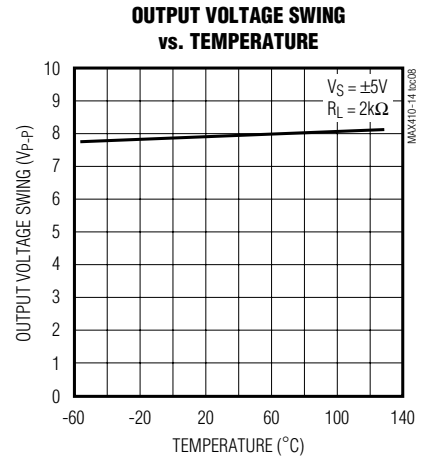
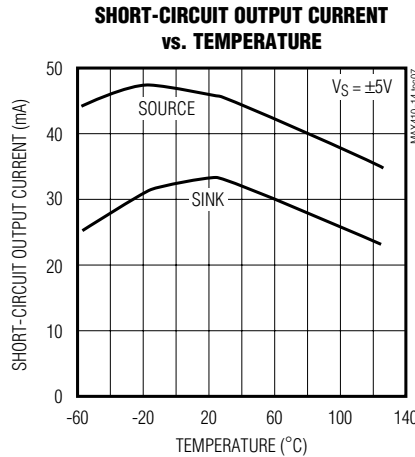
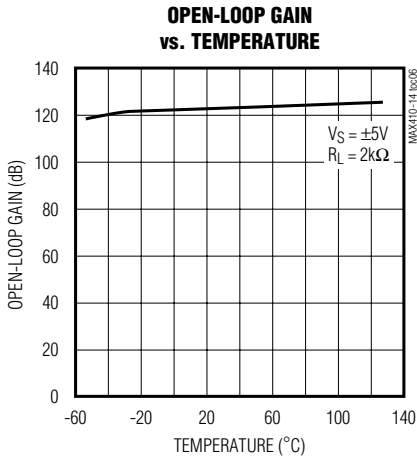
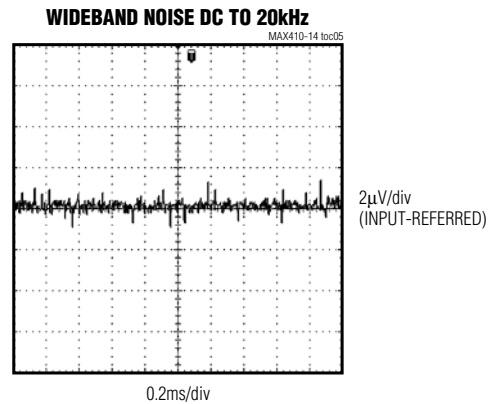
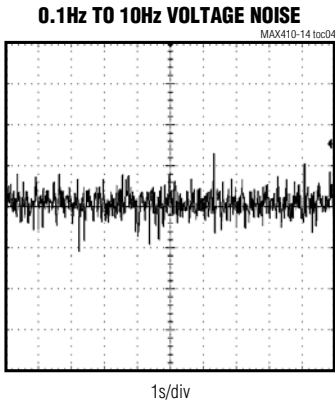
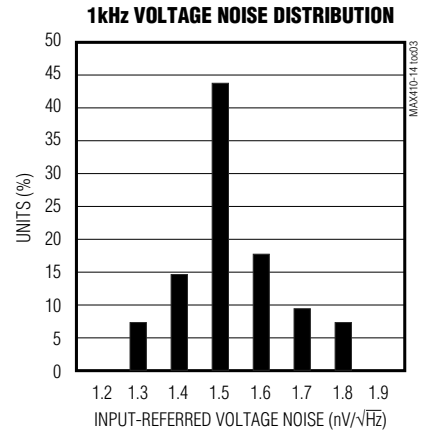
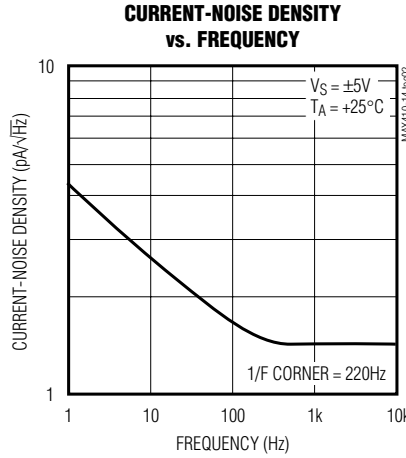
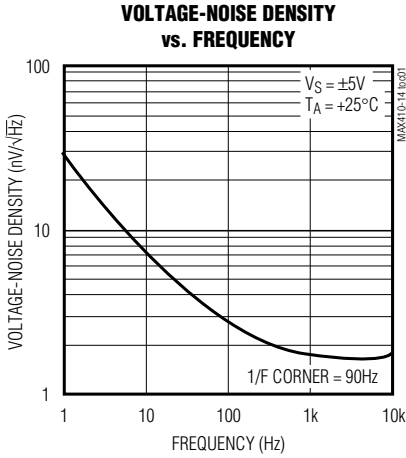

Single/Dual/Quad, 28MHz, Low-Noise, Low-Voltage, Precision Op Amps

Typical Operating Characteristics (continued)

($V_+ = 5V$, $V_- = -5V$, $T_A = +25^\circ C$, unless otherwise noted.)

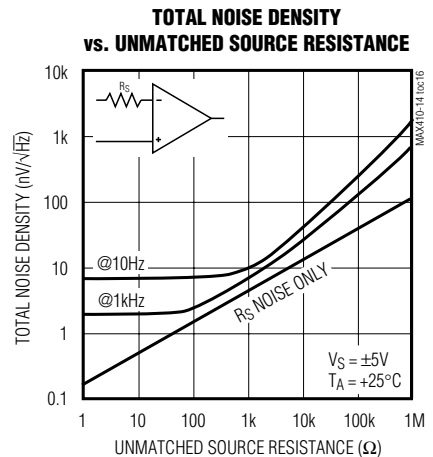
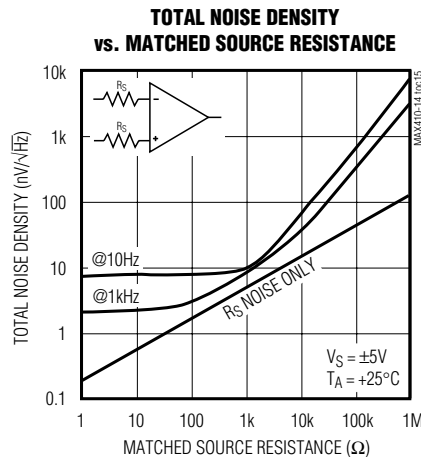
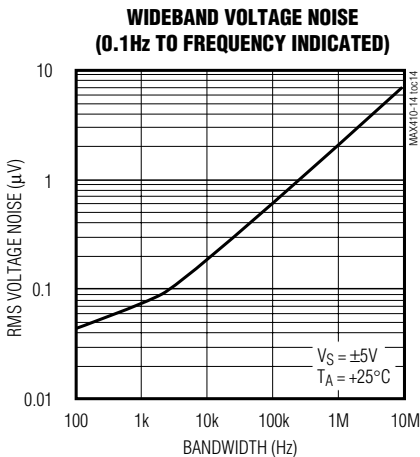
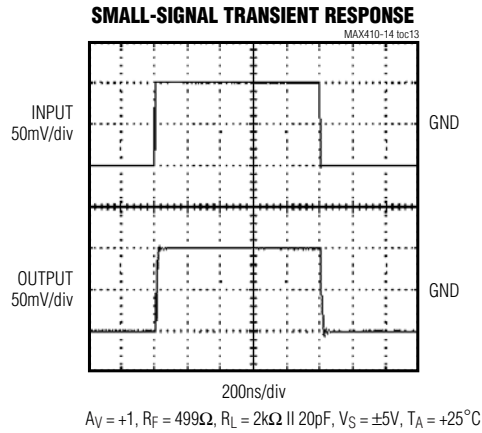
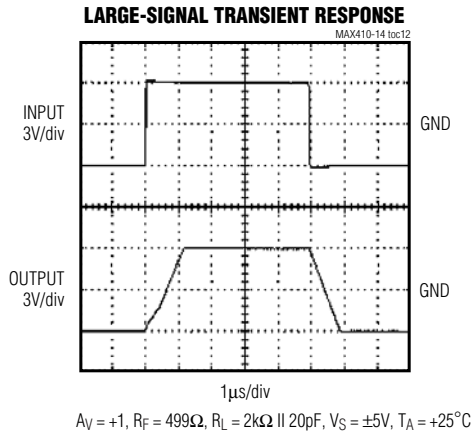
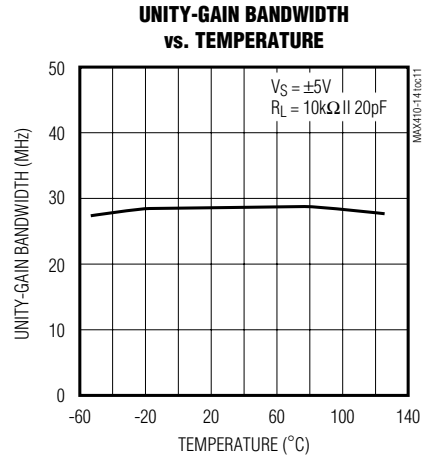
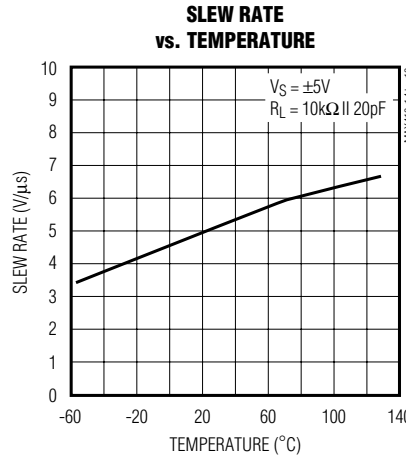
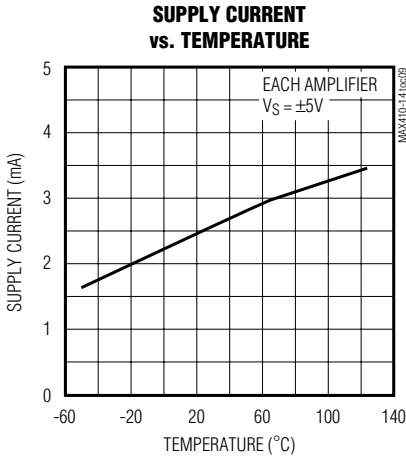

Single/Dual/Quad, 28MHz, Low-Noise, Low-Voltage, Precision Op Amps

Typical Operating Characteristics (continued)

($V_+ = 5V$, $V_- = -5V$, $T_A = +25^\circ C$, unless otherwise noted.)

MAX410/MAX412/MAX414

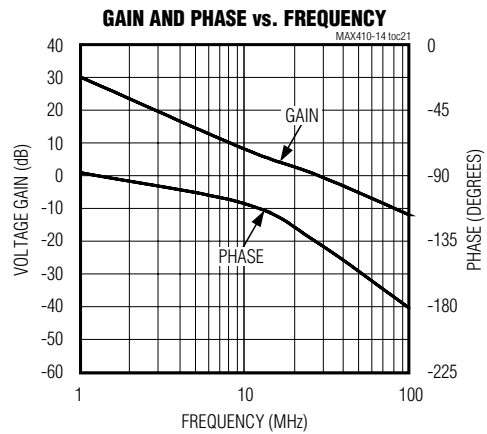
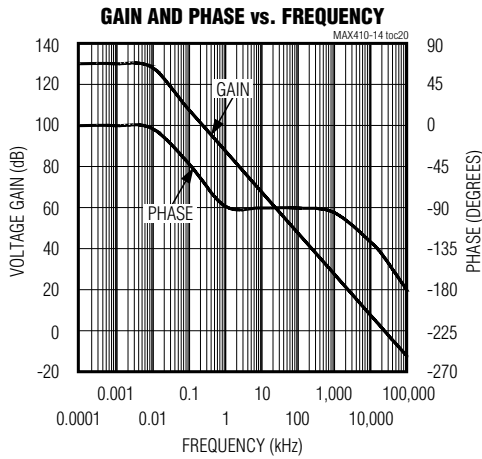
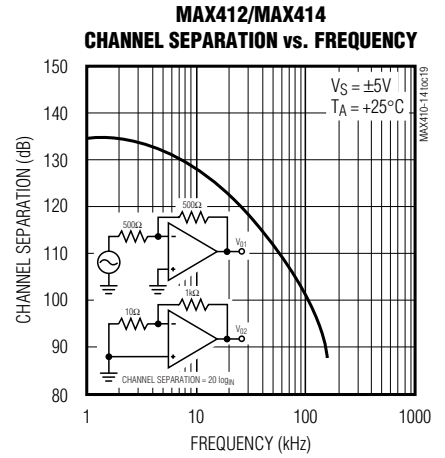
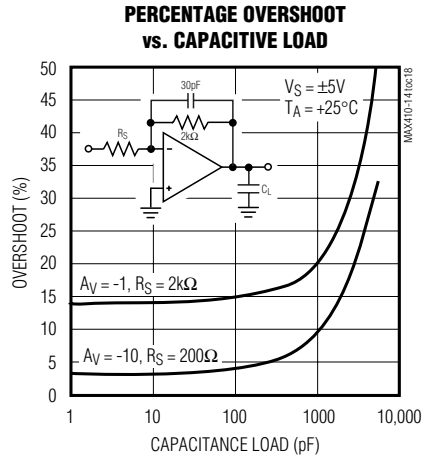
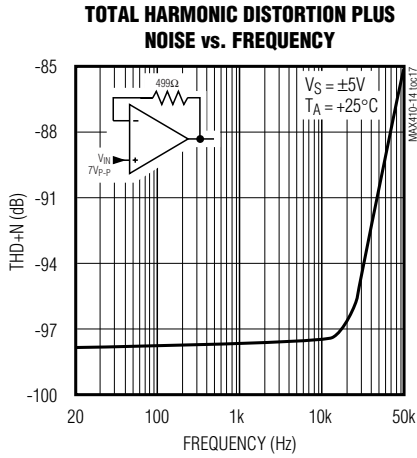

Single/Dual/Quad, 28MHz, Low-Noise, Low-Voltage, Precision Op Amps

Applications Information

The MAX410/MAX412/MAX414 provide low voltage-noise performance. Obtaining low voltage noise from a bipolar op amp requires high collector currents in the input stage, since voltage noise is inversely proportional to the square root of the input stage collector current. However, op amp current noise is proportional to the square root of the input stage collector current, and the input bias current is proportional to the input stage collector current. Therefore, to obtain optimum low-noise performance, DC accuracy, and AC stability, minimize the value of the feedback and source resistance.

Total Noise Density vs. Source Resistance

The standard expression for the total input-referred noise of an op amp at a given frequency is:

$$e_t = \sqrt{e_n^2 + (R_p + R_n)^2 i_n^2 + 4kT (R_p + R_n)}$$

where:

R_n = Inverting input effective series resistance

R_p = Noninverting input effective series resistance

e_n = Input voltage-noise density at the frequency of interest

i_n = Input current-noise density at the frequency of interest

T = Ambient temperature in Kelvin (K)

$k = 1.28 \times 10^{-23}$ J/K (Boltzman's constant)

In Figure 1, $R_p = R_3$ and $R_n = R_1 \parallel R_2$. In a real application, the output resistance of the source driving the input must be included with R_p and R_n . The following example demonstrates how to calculate the total output-noise density at a frequency of 1kHz for the MAX412 circuit in Figure 1.

Gain = 1000

$4kT$ at $+25^\circ\text{C} = 1.64 \times 10^{-20}$

$R_p = 100\Omega$

$R_n = 100\Omega \parallel 100k\Omega = 99.9 \Omega$

$e_n = 1.5\text{nV}/\sqrt{\text{Hz}}$ at 1kHz

$i_n = 1.2\text{pA}/\sqrt{\text{Hz}}$ at 1kHz

$e_t = [(1.5 \times 10^{-9})^2 + (100 + 99.9)^2 (1.2 \times 10^{-12})^2 + (1.64 \times 10^{-20}) (100 + 99.9)]^{1/2} = 2.36\text{nV}/\sqrt{\text{Hz}}$ at 1kHz

Output noise density = $(100)e_t = 2.36\mu\text{V}/\sqrt{\text{Hz}}$ at 1kHz.

In general, the amplifier's voltage noise dominates with equivalent source resistances less than 200Ω . As the equivalent source resistance increases, resistor noise

becomes the dominant term, eventually making the voltage noise contribution from the MAX410/MAX412/MAX414 negligible. As the source resistance is further increased, current noise becomes dominant. For example, when the equivalent source resistance is greater than $3k\Omega$ at 1kHz, the current noise component is larger than the resistor noise. The graph of Total Noise Density vs. Matched Source Resistance in the *Typical Operating Characteristics* shows this phenomenon. Optimal MAX410/MAX412/MAX414 noise performance and minimal total noise achieved with an equivalent source resistance of less than $10k\Omega$.

Voltage Noise Testing

RMS voltage-noise density is measured with the circuit shown in Figure 2, using the Quan Tech model 5173 noise analyzer, or equivalent. The voltage-noise density at 1kHz is sample tested on production units. When measuring op-amp voltage noise, only low-value, metal film resistors are used in the test fixture.

The 0.1Hz to 10Hz peak-to-peak noise of the MAX410/MAX412/MAX414 is measured using the test

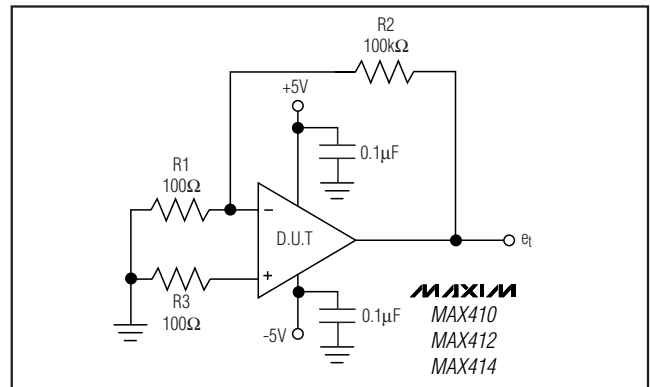

Figure 1. Total Noise vs. Source Resistance Example

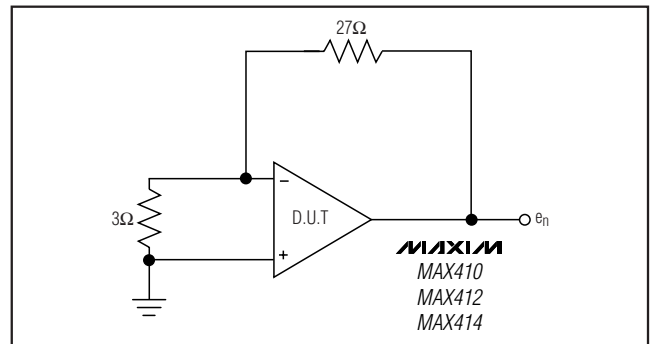

Figure 2. Voltage-Noise Density Test Circuit

Single/Dual/Quad, 28MHz, Low-Noise, Low-Voltage, Precision Op Amps

MAX410/MAX412/MAX414

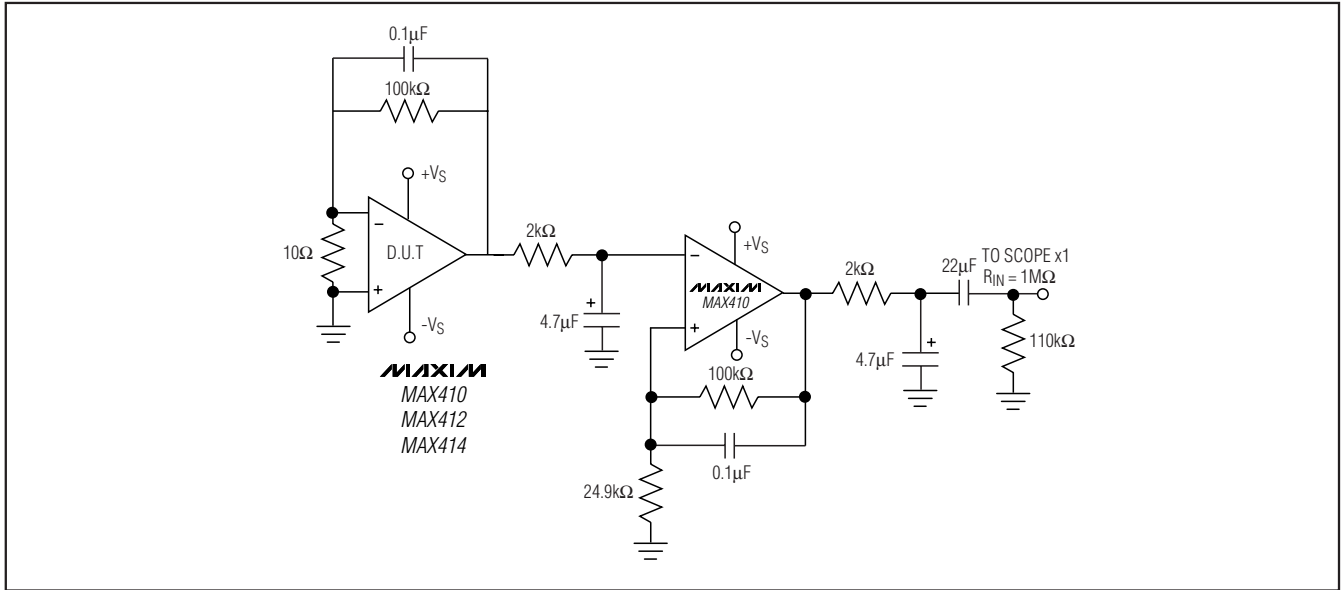

Figure 3. 0.1Hz to 10Hz Voltage Noise Test Circuit

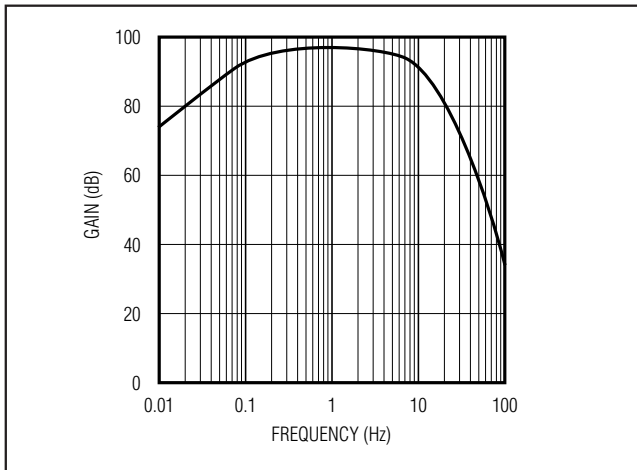

Figure 4. 0.1Hz to 10Hz Voltage Noise Test Circuit, Frequency Response

circuit shown in Figure 3. Figure 4 shows the frequency response of the circuit. The test time for the 0.1Hz to 10Hz noise measurement should be limited to 10 seconds, which has the effect of adding a second zero to the test circuit, providing increased attenuation for frequencies below 0.1Hz.

Current Noise Testing

The current-noise density can be calculated, once the value of the input-referred noise is determined, by using the standard expression given below:

$$i_n = \frac{\sqrt{e_{no}^2 - [(A_{VCL})^2(4KT)(R_n + R_p)]}}{(R_n + R_p)(A_{VCL})} A/\sqrt{Hz}$$

where:

R_n = Inverting input effective series resistance

R_p = Noninverting input effective series resistance

e_{no} = Output voltage-noise density at the frequency of interest (V/\sqrt{Hz})

i_n = Input current-noise density at the frequency of interest (A/\sqrt{Hz})

A_{VCL} = Closed-loop gain

T = Ambient temperature in Kelvin (K)

$k = 1.38 \times 10^{-23}$ J/K (Boltzman's constant)

R_p and R_n include the resistances of the input driving source(s), if any.

If the Quan Tech model 5173 is used, then the A_{VCL} terms in the numerator and denominator of the equation given above should be eliminated because the Quan

Single/Dual/Quad, 28MHz, Low-Noise, Low-Voltage, Precision Op Amps

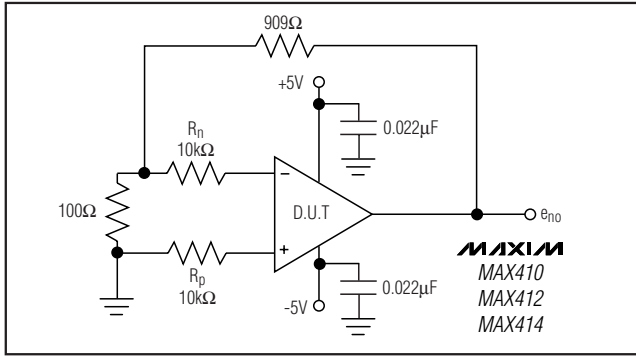

Figure 5. Current-Noise Test Circuit

Tech measures input-referred noise. For the circuit in Figure 5, assuming R_p is approximately equal to R_n and the measurement is taken with the Quan Tech model 5173, the equation simplifies to:

$$i_n = \frac{\sqrt{e_{no}^2 - [(1.64 \times 10^{-20})(20 \times 10^3)]}}{(20 \times 10^3)} \text{ A}/\sqrt{\text{Hz}}$$

Input Protection

To protect amplifier inputs from excessive differential input voltages, most modern op amps contain input protection diodes and current-limiting resistors. These resistors increase the amplifier's input-referred noise. They have not been included in the MAX410/MAX412/MAX414, to optimize noise performance. The MAX410/MAX412/MAX414 do contain back-to-back input protection diodes which will protect the amplifier for differential input voltages of $\pm 0.1\text{V}$. If the amplifier must be protected from higher differential input voltages, add external current-limiting resistors in series with the op amp inputs to limit the potential input current to less than 20mA.

Capacitive-Load Driving

Driving large capacitive loads increases the likelihood of oscillation in amplifier circuits. This is especially true for circuits with high loop gains, like voltage followers. The output impedance of the amplifier and a capacitive load form an RC network that adds a pole to the loop response. If the pole frequency is low enough, as when driving a large capacitive load, the circuit phase margin is degraded.

In voltage follower circuits, the MAX410/MAX412/MAX414 remain stable while driving capacitive loads as great as 3900pF (see Figures 6a and 6b).

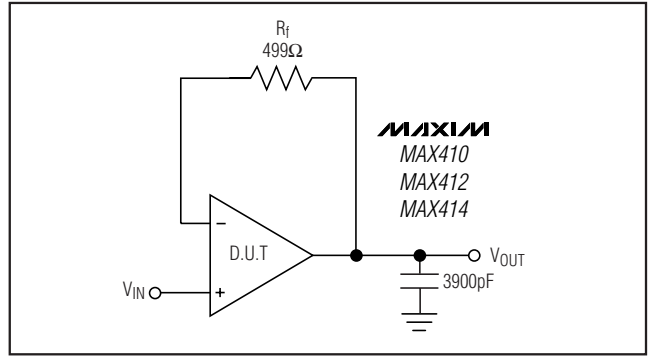

Figure 6a. Voltage Follower Circuit with 3900pF Load

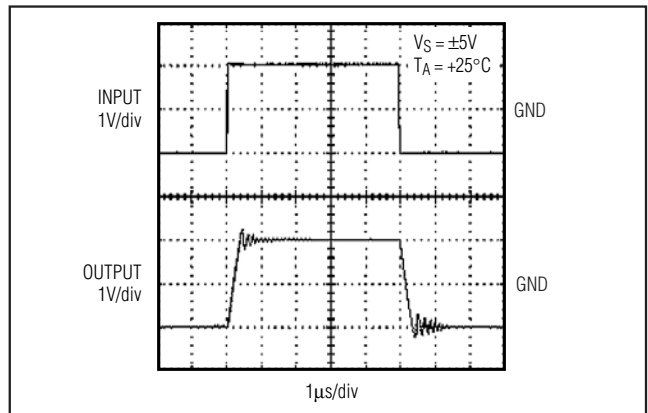

Figure 6b. Driving 3900pF Load as Shown in Figure 6a

When driving capacitive loads greater than 3900pF, add an output isolation resistor to the voltage follower circuit, as shown in Figure 7a. This resistor isolates the load capacitance from the amplifier output and restores the phase margin. Figure 7b is a photograph of the response of a MAX410/MAX412/MAX414 driving a 0.015μF load with a 10Ω isolation resistor

The capacitive-load driving performance of the MAX410/MAX412/MAX414 is plotted for closed-loop gains of -1V/V and -10V/V in the % Overshoot vs. Capacitive Load graph in the *Typical Operating Characteristics*.

Feedback around the isolation resistor R_I increases the accuracy at the capacitively loaded output (see Figure 8). The MAX410/MAX412/MAX414 are stable with a 0.01μF load for the values of R_I and C_F shown. In general, for decreased closed-loop gain, increase R_I or C_F . To drive larger capacitive loads, increase the value of C_F .

Single/Dual/Quad, 28MHz, Low-Noise, Low-Voltage, Precision Op Amps

MAX410/MAX412/MAX414

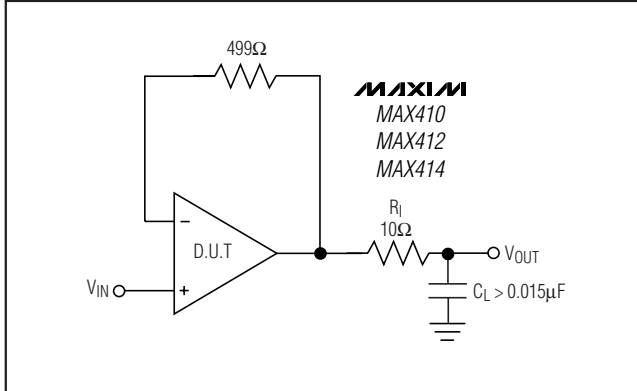

Figure 7a. Capacitive-Load Driving Circuit

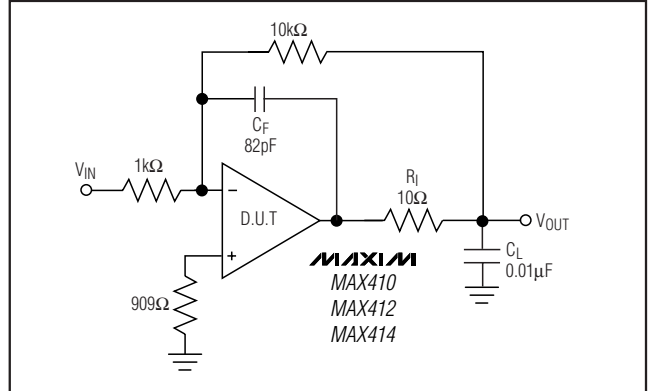

Figure 8. Capacitive-Load Driving Circuit with Loop-Enclosed Isolation Resistor

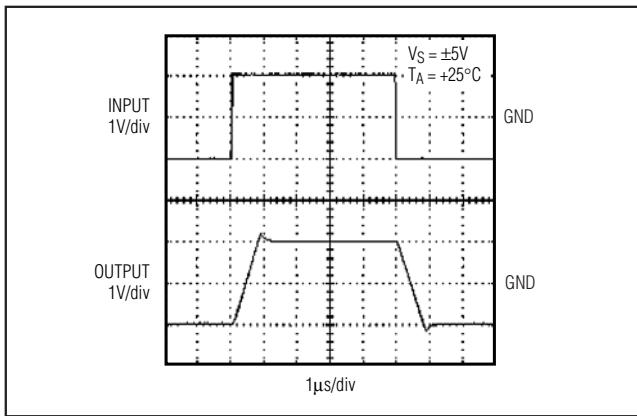

Figure 7b. Driving a 0.015μF Load with a 10Ω Isolation Resistor

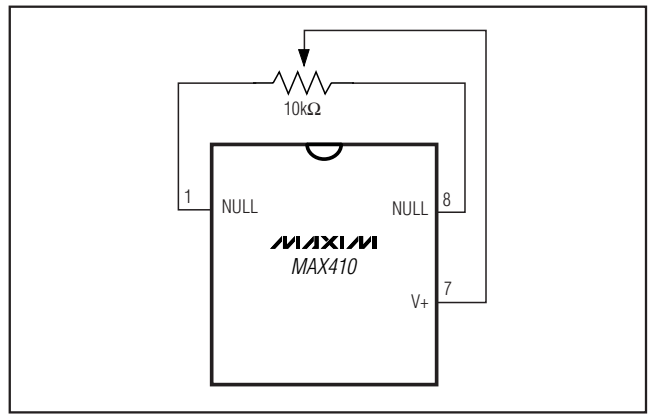

Figure 9. MAX410 Offset Null Circuit

TDFN Exposed Paddle Connection

On TDFN packages, there is an exposed paddle that does not carry any current but should be connected to V- (not the GND plane) for rated power dissipation.

Total Supply Voltage Considerations

Although the MAX410/MAX412/MAX414 are specified with ±5V power supplies, they are also capable of single-supply operation with voltages as low as 4.8V. The minimum input voltage range for normal amplifier operation is between V- + 1.5V and V+ - 1.5V. The minimum room-temperature output voltage range (with 2kΩ load)

is between V+ - 1.4V and V- + 1.3V for total supply voltages between 4.8V and 10V. The output voltage range, referenced to the supply voltages, decreases slightly over temperature, as indicated in the ±5V *Electrical Characteristics* tables. Operating characteristics at total supply, voltages of less than 10V are guaranteed by design and PSRR tests.

MAX410 Offset Voltage Null

The offset null circuit of Figure 9 provides approximately ±450μV of offset adjustment range, sufficient for zeroing offset over the full operating temperature range.

Single/Dual/Quad, 28MHz, Low-Noise, Low-Voltage, Precision Op Amps

Ordering Information (continued)

PART	TEMP RANGE	PIN-PACKAGE
MAX412CPA	0°C to +70°C	8 Plastic DIP
MAX412BCPA	0°C to +70°C	8 Plastic DIP
MAX412CSA	0°C to +70°C	8 SO
MAX412BCSA	0°C to +70°C	8 SO
MAX412EPA	-40°C to +85°C	8 Plastic DIP
MAX412BEPA	-40°C to +85°C	8 Plastic DIP
MAX412ESA	-40°C to +85°C	8 SO
MAX412BESA	-40°C to +85°C	8 SO
MAX414CPD	0°C to +70°C	14 Plastic DIP
MAX414BCPD	0°C to +70°C	14 Plastic DIP
MAX414CSD	0°C to +70°C	14 SO
MAX414BCSD	0°C to +70°C	14 SO
MAX414EPD	-40°C to +85°C	14 Plastic DIP
MAX414BEPD	-40°C to +85°C	14 Plastic DIP
MAX414ESD	-40°C to +85°C	14 SO
MAX414BESD	-40°C to +85°C	14 SO

Pin Configurations (continued)

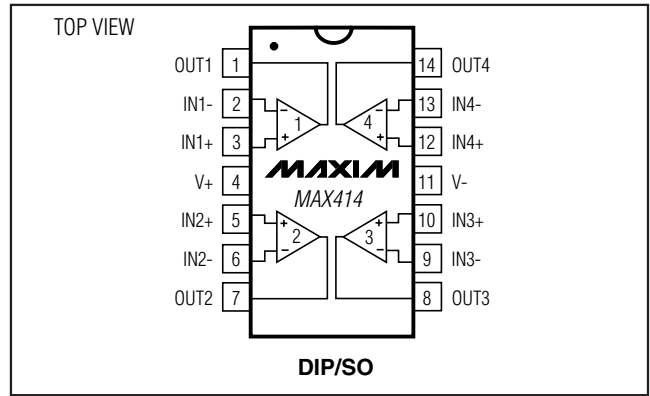

Chip Information

MAX410 TRANSISTOR COUNT: 132
 MAX412 TRANSISTOR COUNT: 262
 MAX414 TRANSISTOR COUNT: 2 × 262 (hybrid)
 PROCESS: Bipolar

Package Information

For the latest package outline information and land patterns, go to www.maxim-ic.com/packages. Note that a "+", "#", or "-" in the package code indicates RoHS status only. Package drawings may show a different suffix character, but the drawing pertains to the package regardless of RoHS status.

PACKAGE TYPE	PACKAGE CODE	DOCUMENT NO.
8 Plastic DIP	P8-1	21-0043
8 SO (MAX410)	S8-2	21-0041
8 SO (MAX412)	S8-4	21-0041
8 TDFN-EP	T833-2	21-0137
14 Plastic DIP	P14-3	21-0043
14 SO	S14-1	21-0041

Single/Dual/Quad, 28MHz, Low-Noise, Low-Voltage, Precision Op Amps

Revision History

REVISION NUMBER	REVISION DATE	DESCRIPTION	PAGES CHANGED
5	10/08	Added rugged plastic product.	1, 11
6	9/09	Added military temperature operating range and new <i>Electrical Characteristics</i> table for the MAX410. Updated <i>Package Information</i> table.	1, 2, 4, 12–13

MAX410/MAX412/MAX414

Maxim cannot assume responsibility for use of any circuitry other than circuitry entirely embodied in a Maxim product. No circuit patent licenses are implied. Maxim reserves the right to change the circuitry and specifications without notice at any time.

Maxim Integrated Products, 120 San Gabriel Drive, Sunnyvale, CA 94086 408-737-7600 _____ 13

Mouser Electronics

Authorized Distributor

Click to View Pricing, Inventory, Delivery & Lifecycle Information:

Maxim Integrated:

[MAX414BCSD](#) [MAX414BCSD+](#) [MAX414BCSD+T](#) [MAX414BEPD](#) [MAX414BESD](#) [MAX414BESD+](#)
[MAX414BESD+T](#) [MAX414CSD+T](#) [MAX414EPD+](#) [MAX414ESD](#) [MAX414BCSD-T](#) [MAX414BESD-T](#) [MAX414CSD-T](#)
[MAX414ESD-T](#) [MAX414MJD](#) [MAX414CPD+](#) [MAX414ESD+](#)