

THIS DOCUMENT IS THE PROPERTY OF
KEYSTONE ELECTRONICS CORP. AND
SHALL NOT BE REPRODUCED, DISTRIBUTED
OR USED AS A BASIS FOR MANUFACTURE
WITHOUT PRIOR WRITTEN PERMISSION
FROM KEYSTONE ELECTRONICS CORP.

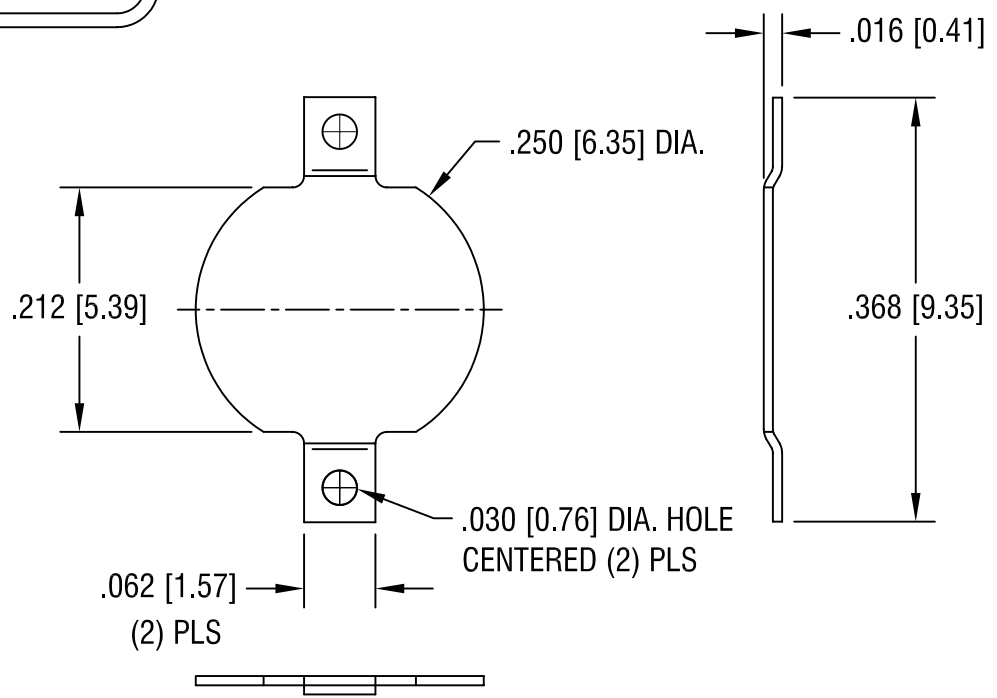
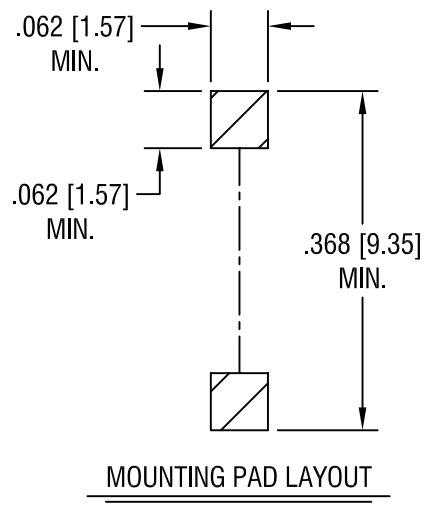

5.9.06	CHANGE AS PER ECN 06-028	A
DATE	DESCRIPTION	REV.

KEYSTONE ELECTRONICS CORP.			
ASTORIA, N.Y. 11105-2017			
PART NAME			
COIN CELL SM NEGATIVE CONTACT			
MATERIAL			
.008 [.20] TH'K BRASS			
FINISH		DRN BY	DATE
TIN NICKEL PLATE		BOONE	12.20.05
		APP'D	SCALE
		LN	6X
TOLERANCES	INCH [MM]	CODE	DWG NO.
DECIMAL	± .005 [± 0.15]	C	2991
ANGULAR	±		
UNLESS OTHERWISE SPECIFIED			

Mouser Electronics

Authorized Distributor

Click to View Pricing, Inventory, Delivery & Lifecycle Information:

[Keystone Electronics:](#)

[2991TR](#)