

## Pin Configuration

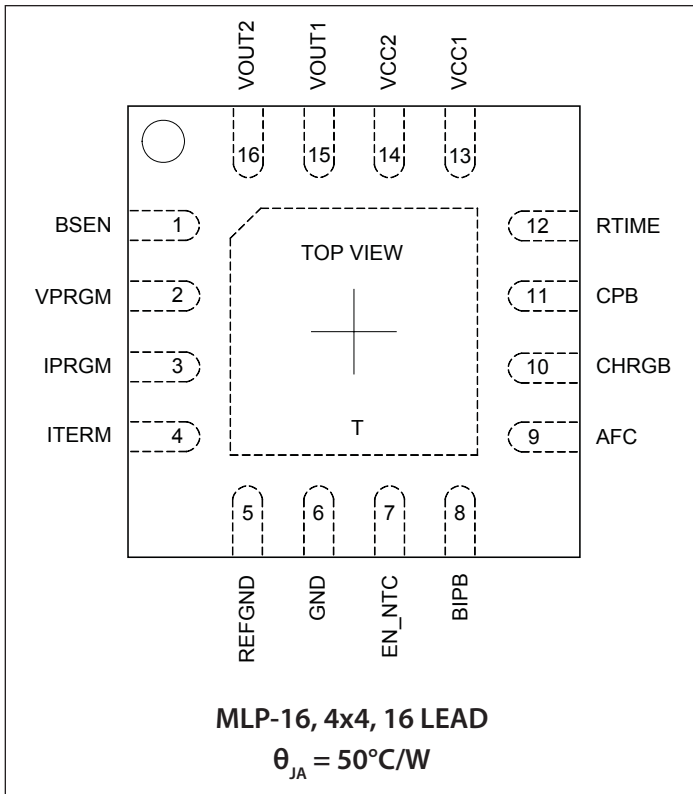

## Ordering Information

Device	Package
SC802IMLTRT <sup>(1)(2)</sup>	MLP16
SC802AIMLTRT <sup>(1)(2)</sup>	MLP16
SC802EVB <sup>(3)</sup>	Evaluation Board
SC802AEVB <sup>(3)</sup>	Evaluation Board

Notes:

- (1) Available in tape and reel only. A reel contains 3,000 devices.
- (2) Available in lead-free package only. Device is WEEE and RoHS compliant.
- (3) Specify the part number when ordering.

## Marking Information

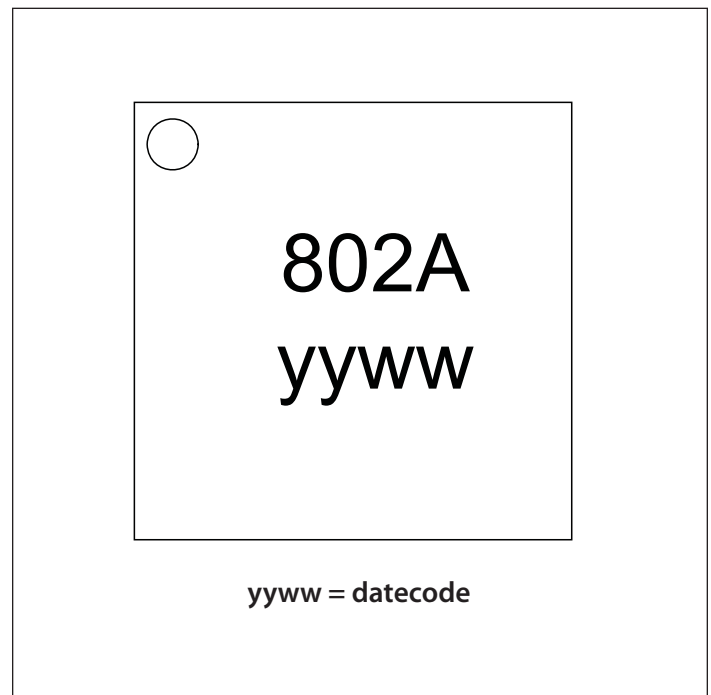
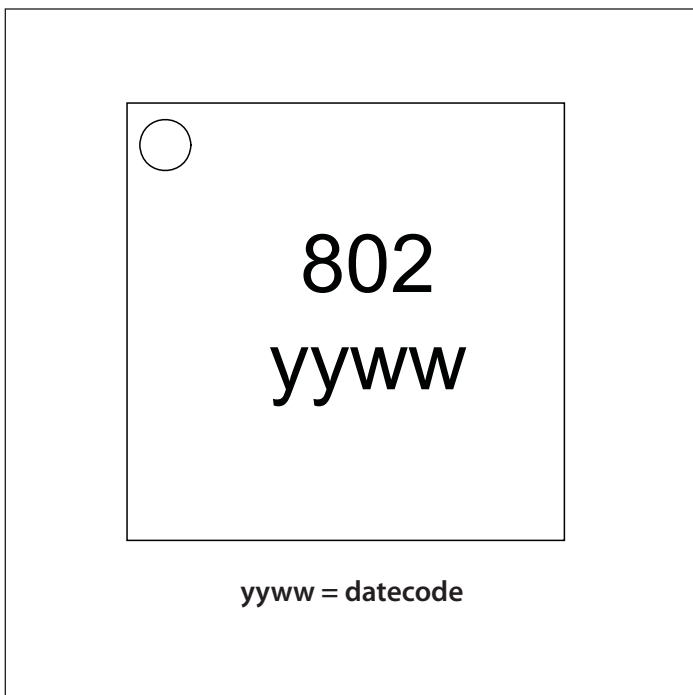

## Absolute Maximum Ratings

VCC1, VCC2, EN_NTC (V) .....	-0.3 to +14.0
VOUT1, VOUT2, RTIME(V) .....	-0.3 to +6.0
BIPB, CPB, CHRGB (V) .....	-0.3 to +6.0
IPRGM, ITERM, AFC (V) .....	-0.3 to +6.0
VPRGM, BSEN (V) .....	-0.3 to +6.0
REFGND to GND (V) .....	-0.3 to +0.3
VOUT Short to GND <sup>(1)</sup> .....	Continuous
ESD Protection Level <sup>(2)</sup> (kV) .....	2

## Recommended Operating Conditions

Ambient Temperature Range (°C).....	$-40 \leq T_A \leq +85$
VCC Operating Voltage <sup>(1)(3)</sup> (V) .....	$4.3 \leq V_{VCC1,2} \leq 6.5$

## Thermal Information

Thermal Resistance, Junction to Ambient <sup>(4)</sup> (°C/W) ....	50
Maximum Junction Temperature (°C) .....	+150
Storage Temperature Range (°C).....	-65 to +150
Peak IR Reflow Temperature (10s to 40s) (°C) .....	+260

Exceeding the above specifications may result in permanent damage to the device or device malfunction. Operation outside of the parameters specified in the Electrical Characteristics section is not recommended.

### NOTES:

- (1) VCC1 and VCC2, and VOUT1 and VOUT2, must be connected, and will be referred to collectively as VCC and VOUT, respectively. All references to  $V_{VCC}$ ,  $V_{VOUT}$ ,  $I_{VCC}$ , and  $I_{VOUT}$  refer to the common node voltage and total current of VCC1 and VCC2, and VOUT1 and VOUT2, respectively.
- (2) Tested according to JEDEC standard JESD22-A114-B.
- (3) Operating voltage is the input voltage at which the charger is guaranteed to begin operation. Maximum operating voltage is the maximum supply as defined in EIA/JEDEC Standard Number 78, paragraph 2.11.
- (4) Calculated from package in still air, mounted to 3 x 4.5(in), 4 layer FR4 PCB with thermal vias under the exposed pad per JESD51 standards.

## Electrical Characteristics

Test Conditions:  $V_{VCC} = 5.00V^{(1)}$ ,  $V_{VOUT} = 3.70V$  unless specified. Typ values at 25°C. Min and Max at  $-40^\circ C < T_A < 85^\circ C$ , unless specified.

Parameter	Symbol	Conditions	Min	Typ	Max	Units
VCC UVLO Rising Threshold	$V_{T_{UVLOR}}$		3.7	4.0	4.3	V
VCC UVLO Hysteresis	$V_{T_{UVLOH}}$			40		mV
VCC OVP Rising Threshold	$V_{T_{OVPR}}$		6.5	6.8	7.5	V
VCC OVP Falling Threshold	$V_{T_{OVPF}}$		6.1	6.5	7.1	V
VCC OVP Hysteresis	$V_{T_{OVPH}}$	$V_{T_{OVPR}} - V_{T_{OVPF}}$	200	300	500	mV
Operating Current	$I_{CC_{DIS}}$	$V_{EN\_NTC} = 0V$ , CHRGB, CPB off		2.6		mA
	$I_{CC_{CHG}}$	$V_{EN\_NTC} = 0.5 \times V_{VCC}$ , CHRGB, CPB off	1	2.4	3.5	
	$I_{CC_{LDO}}$	LDO Mode, CHRGB, CPB off	8	16	23	
Battery Leakage Current (sum of $I_{VOUT}$ and $I_{BSEN}$ )	$I_{Leak_{BAT}}$	$V_{VCC} = 0V$ , $V_{VOUT} = V_{BSEN} = 4.5V$		0.1	2	$\mu A$
Regulated Voltage	$V_{CV\_HI}$	$V_{VPRGM} = V_{VCC}$	4.16	4.20	4.24	V
	$V_{CV\_LO}$	$V_{VPRGM} = 0V$	4.06	4.10	4.14	
REFGND Output Accuracy	$V_{VOUT\_RGND}$	$V_{VOUT\_RGND} = V_{VOUT} - V_{CV}$ , $V_{REFGND} = 30mV$	22	30	38	mV
REFGND Current	$I_{REFGND}$	$V_{REFGND} = 0V$		35		$\mu A$

## Electrical Characteristics (continued)

Parameter	Symbol	Conditions	Min	Typ	Max	Units
Adjust Mode Feedback Voltage	$V_{ADJMF}$	VPRGM = External Divider, $4.2V \leq V_{CC} \leq 6.5V$		3.0		V
Adjust Mode VPRGM Shunt Resistance	$R_{VPGMSH}$	Adjust Mode, $V_{VPRGM} = 0.1V$	0.5	1	5	k $\Omega$
Adjust Mode Threshold Voltage	$V_{T_{ADJM}}$	$V_{VOUT} - V_{BSEN}$	50	250	420	mV
SC802 Pre-Charge Current	$I_{PREQ}$	$R_{ITERM} = 3.01k\Omega$	74	82	90	mA
SC802 Termination Current	$I_{TERMQ}$	$R_{ITERM} = 3.01k\Omega$	35.5	42	49.5	mA
SC802 Fast-Charge Current	$I_{FastQ}$	$R_{IPRGM} = 3.01k\Omega$ , $V_{VOUT} = 3.8V$	450	500	550	mA
SC802 AFC Fast-Charge Current	$I_{FQ\_ADJ}$	$R_{IPRGM} = 3.01k\Omega$ , $V_{AFC} = 0.75V$	200	240	280	mA
SC802A Pre-Charge Current	$I_{PREQA}$	$R_{ITERM} = 976\Omega$	135	145	160	mA
SC802A Termination Current	$I_{TERMQA}$	$R_{ITERM} = 976\Omega$	135	145	160	mA
SC802A Fast-Charge Current	$I_{FastQA}$	$R_{IPRGM} = 1.78k\Omega$ , $R_{ITERM} = 976\Omega$ , $V_{VOUT} = 3.8V$	740	800	860	mA
SC802A AFC Fast-Charge Current	$I_{FQ\_ADJA}$	$R_{IPRGM} = 1.78k\Omega$ , $R_{ITERM} = 976\Omega$ , $V_{AFC} = 0.75V$ , $V_{VOUT} = 3.8V$	310	367	430	mA
$I_{PROG}$ Regulated Voltage	$V_{IPRGM}$		1.4	4.5	1.6	V
$V_{VOUT}$ Pre-charge Threshold <sup>(2)</sup>	$V_{T_{PreQ}}$	measured at VOUT pins	2.7	2.8	2.9	V
$V_{VOUT}$ Re-charge Threshold <sup>(3)</sup>	$V_{T_{ReQ}}$	$V_{CV}$ (at BSEN) - $V_{BSEN-FDBK}$	70	100	140	mV
Over Temperature Shutdown	$T_{OT-R}$	Hysteresis = 10°C		150		°C
EN_NTC Thresholds	$V_{T_{NTC\_DIS}}$	Disable (Falling)	0.5	<1	1.1	V
	$RT_{NTC\_HF}$	NTC Hot (Falling), tested at $V_{VCC} = 5V$	28	30	32	%
	$RT_{NTC\_CR}$	NTC Cold (Rising), tested at $V_{VCC} = 5V$	72	75	78	%
	$RT_{NTC\_EN}$	Charger Enable, tested at $V_{VCC} = 5V$	84	90	92	%
	$V_{T_{NTC\_HYS}}$	Hot/Cold threshold hysteresis, tested at $V_{VCC} = 5V$		50		mV
Timer Disable Threshold	$V_{T_{TIMER}}$	$V_{RTIME} < V_{T_{TIMER}}$ Disables Timer	0.7	1	1.1	V
Internal Timer Select	$V_{T_{INTTS}}$	$V_{CC} - V_{RTIME} < V_{T_{INTTS}}$ selects internal timer		1.5		V
External RTIME Voltage	$V_{RTIME}$	RTIME tied through 36.5k $\Omega$ to GND	1.4	1.5	1.6	V
Pre-Charge Fault Time-out	$T_{PreQF}$	RTIME tied through 36.5k $\Omega$ to GND	50			min
		RTIME tied to VCC	-35%	45	+35	
Charge Complete Time-out	$T_{QCOMP}$	RTIME tied through 36.5k $\Omega$ to GND		3.3		hr
		RTIME tied to VCC	-35%	3	+35	

## Electrical Characteristics (continued)

Parameter	Symbol	Conditions	Min	Typ	Max	Units
CHRGB Charge LED On	$V_{\text{CHRGB}}$	Load = 5mA		0.5	1	V
CHRGB Charge LED OFF	$I_{\text{CHRGB}}$	Leakage Current, V = 5V			1	$\mu\text{A}$
CPB LED On	$V_{\text{CPB}}$	Load = 5mA		0.5	1	V
CPB LED Off	$I_{\text{CPB}}$	Leakage Current, V = 5V			1	$\mu\text{A}$
BIPB, VPRGM Inputs	$V_{\text{IH}}$			1.8		V
	$V_{\text{IL}}$				0.4	

### Notes:

- (1) Electrical Characteristics apply for  $V_{\text{VIN}} = 4.75\text{V}$  to  $5.25\text{V}$ , but are tested only at  $V_{\text{VIN}} = 5.00\text{V}$ , unless noted.
- (2) Pre-charge threshold is applied directly at VOUT for any setting of  $V_{\text{CV}}$ , whether 4.1V or 4.2V fixed, or Adjust Mode.
- (3) Re-charge threshold is relative to  $V_{\text{CV}}$  as measured at BSEN. For either of the fixed output voltage settings,  $V_{\text{BSEN}}$  is compared directly to the programmed CV regulation voltage. In Adjust Mode,  $V_{\text{BSEN}}$  is compared to the Adjust Mode feedback voltage,  $V_{\text{ADJMF}}$ . So the re-charge threshold at the battery is  $V_{\text{T}_{\text{ReQ}}} \times V_{\text{CV}} / V_{\text{BSEN-FDBK}}$ .

**Typical Characteristics**

**Output Current (SC802) versus  $R_{IPRGM}$**

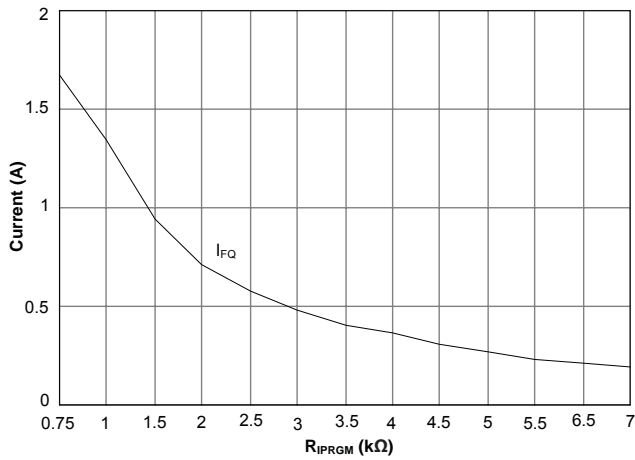

**Output Current (SC802) versus  $R_{ITERM}$**

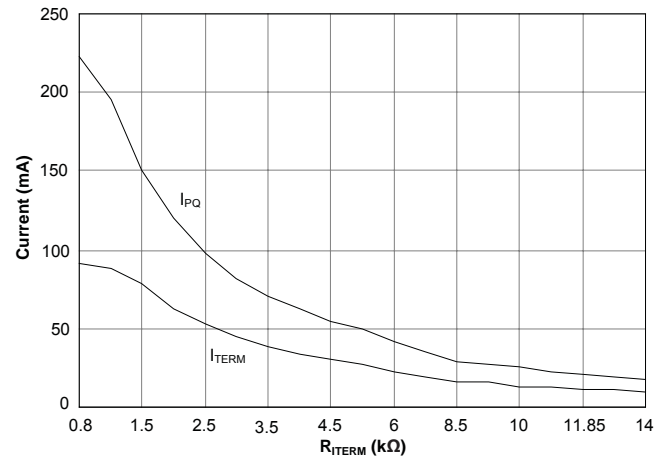

**Drop-out Voltage versus Output Current**

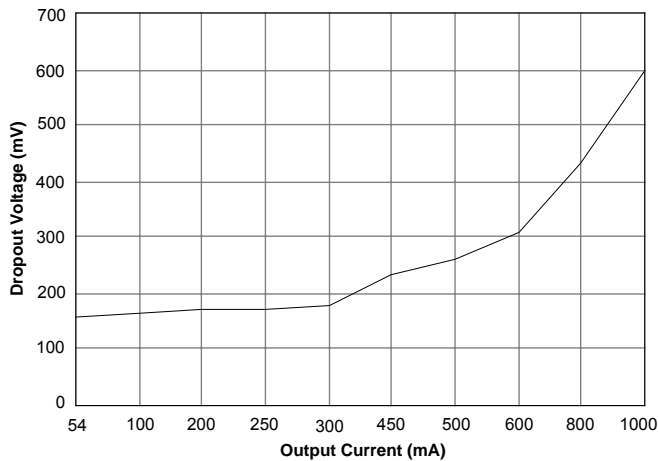

**Time-out versus Output  $R_{RTIME}$**

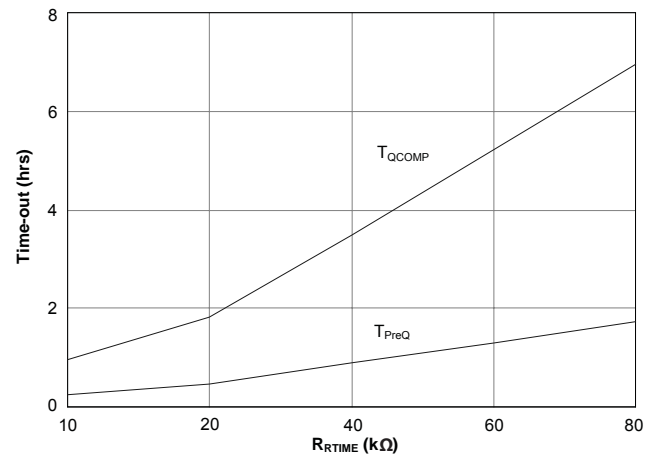

**Battery Charge Profile**

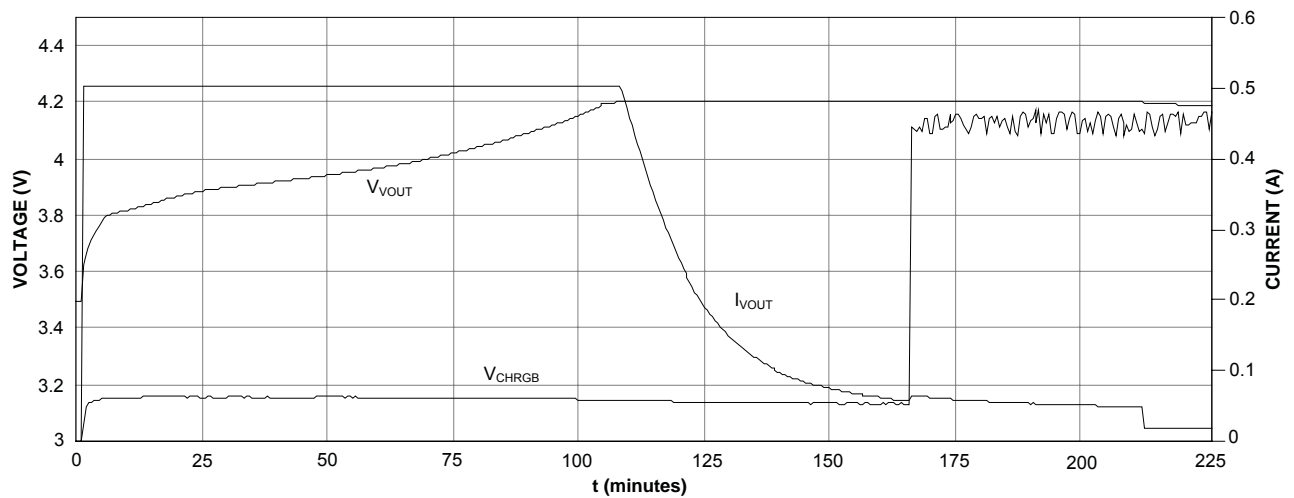

## Pin Descriptions

Pin #	Pin Name	Pin Function
1	BSEN	Battery voltage sense pin — Connect to battery terminal to Kelvin sense battery voltage, to a resistor divider network for adjustable output voltage, or to VOUT otherwise. Do not leave this pin floating.
2	VPRGM	Selectable voltage program pin — Logic low = 4.1V; Logic high = 4.2V; Resistor = adjustable.
3	IPRGM	Charger current program pin in fast-charge mode — Requires a resistor to ground to program fast-charge current.
4	ITERM	Selection for current termination and pre-charge current — Requires a resistor to ground to program pre-charge and termination current.
5	REFGND	Reference ground — Allows Kelvin connection to battery negative terminal.
6	GND	Ground
7	EN_NTC	Combined device enable/disable and NTC input pin — Logic high enables device; logic low disables device. Analog voltages between $0.3 \times V_{VCC}$ and $0.75 \times V_{VCC}$ enable the NTC function.
8	BIPB	Battery In Place Bar (BIPB) — selects Charge/LDO mode. BIPB = Low selects charge mode. BIPB = High selects LDO mode which disables Pre-Charge and timer functions
9	AFC	Analog fast-charge setting — Connect to DAC for analog control of fast-charge current value. Connect to VCC to disable AFC. Do not leave open.
10	CHRGB	Open drain charger status pin — The output is active low when the charger is on and $I_{VOUT} > I_{TERM}$ . The CHRGB output switches to high impedance when $I_{VOUT} < I_{TERM}$ . This pin can sink 10mA.
11	CPB	Open Drain Charger present indicator — The output is active low when the $V_{VCC}$ exceeds $V_{UVLOR}$ . This pin can sink 10mA.
12	RTIME	Programmable timer input pin — Connect to VCC to select the internal time-out of 3hrs. Connect an external resistor to ground to program the timeout period. Connect to ground to disable the timer.
13	VCC1	Supply pin — Connect to adaptor power and to VCC2. <sup>(1)</sup>
14	VCC2	Supply pin — Connect to adaptor power and to VCC1. <sup>(1)</sup>
15	VOUT1	Charger output — Connect to battery and to VOUT2. <sup>(2)</sup>
16	VOUT2	Charger output — Connect to battery and to VOUT1. <sup>(2)</sup>
T	Thermal Pad	Pad is for heatsinking purposes — The thermal pad is not connected internally. Connect exposed pad to ground plane using multiple vias.

### Notes:

- (1) VCC1 and VCC2 must be connected. VCC1 and VCC2 will be referred to collectively as VCC. All references to  $V_{VCC}$  and  $I_{VCC}$  refer to the common node voltage and total current of VCC1 and VCC2.
- (2) VOUT1 and VOUT2 must be connected. VOUT1 and VOUT2 will be referred to collectively as VOUT. All references to  $V_{VOUT}$  and  $I_{VOUT}$  refer to the common node voltage and total current of VOUT1 and VOUT2.

**Block Diagram**

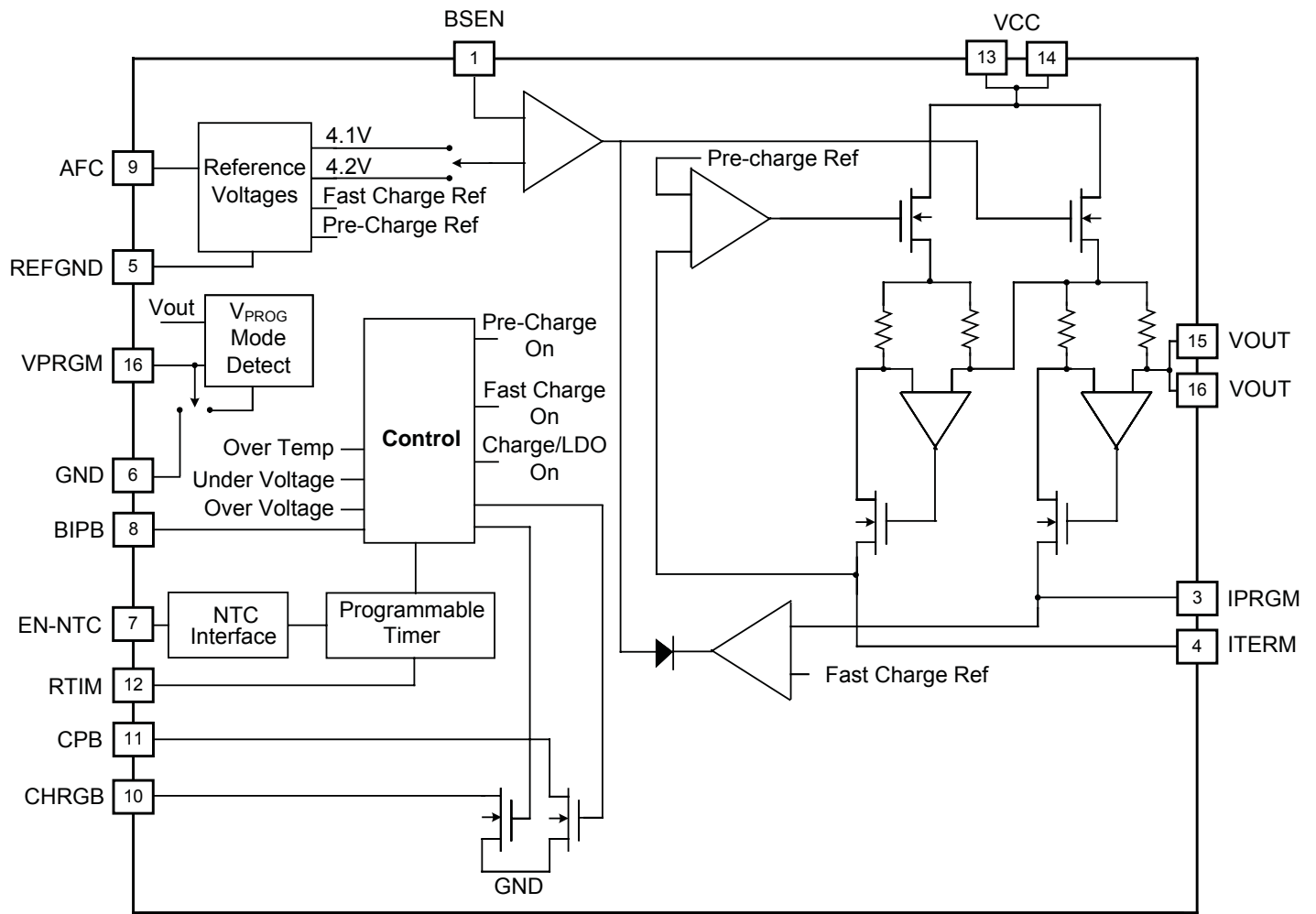

## Applications Information

### General Operation

The SC802 and SC802A can be configured independently with respect to fast-charge and termination current, output voltage, timing, and operation with and without a battery (LDO mode). A typical charging cycle is described in this section. Details on alternate applications and output programmability are covered in subsequent sections. Wherever the SC802 and SC802A descriptions are the same, the part will be referred to as the SC802/A.

The charging cycle begins when the adapter is plugged in. The SC802/A performs glitch filtering on the VCC input and initiates a charge cycle when  $V_{VCC} > VT_{UVLOR}$ . The CPB and CHRGB signals turn on the charger LED's. If the battery voltage is less than 2.8V, the SC802/A will charge the output with the pre-charge current. When the battery voltage exceeds 2.8V, the SC802/A enters fast-charge or Constant Current (CC) regulation. When the battery voltage reaches its final value, the charger enters Constant Voltage (CV) regulation. The CV regulation output voltage, ( $V_{CV}$ ), can be programmed to fixed values  $V_{CV-HI} = 4.2V$ ,  $V_{CV-LO} = 4.1V$ , or programmed to any voltage  $V_{CV-ADJ}$  using the available Adjust Mode. In CV regulation the battery accepts decreasing current until the output current ( $I_{VOUT}$ ) reaches the programmed termination current, designated ( $I_{TERM}$ ).

When  $I_{VOUT} < I_{TERM}$ , an event known as charge termination, the CHRGB status indicator turns off, but the SC802/A continues to hold the battery in CV regulation until the timer cycle is completed. At this point the charger enters the monitor state where the output remains off until  $V_{VOUT}$  drops by  $VT_{ReQ}$  nominally 100mV, and a new charge cycle is initiated.

### Termination Current

When the battery reaches the CV voltage ( $V_{CV}$ ), the charger transitions from a constant current source to a constant voltage source. The current through the battery begins to decrease while the voltage remains constant until the current decreases below the programmed termination current set by the ITERM pin resistance to ground. Upon termination, the SC802/A will turn off the CHRGB status indicator. If the timer is enabled, the output will remain in CV regulation until the timer cycle is complete. If the timer is disabled, then the output will turn off as soon as the termination current level is reached. The termination

current is programmed according to the following equations.

$$I_{TERM} = \frac{1.5}{R_{ITERM}} \times 88 \quad (SC802)$$

$$I_{TERM} = \frac{1.5}{R_{ITERM}} \times 97 \quad (SC802A)$$

The termination current is programmable up to 67mA for the SC802, and up to 150mA for the SC802A.

### Pre-Charge

Pre-charge regulation is automatically enabled when the battery voltage is below the pre-charge threshold,  $VT_{PreQ}$  nominally 2.8V. Pre-charge is required to precondition the battery for fast-charging, and to limit the power dissipation in the charger. The pre-charge current value,  $I_{PQ}$  is determined by the ITERM pin resistance to ground. The pre-charge current is programmable from 10mA to 125mA with the SC802, and up to 150mA with the SC802A. The pre-charge current is given by the following equations.

$$I_{PQ} = \frac{2.8}{R_{ITERM}} \times 88 \quad (SC802)$$

$$I_{PQ} = \frac{1.5}{R_{ITERM}} \times 97 \quad (SC802A)$$

If the charge timer is enabled, a pre-charge timer is also enabled. If the pre-charge time exceeds 1/4 of the programmed total charge time, the charger will turn off and a pre-charge fault will be indicated by blinking the CHRGB status indicator. This fault is cleared when the charger is disabled (by grounding the EN\_NTC pin), or the VCC input voltage is cycled, or the output voltage rises above 2.8V.

### Fast-Charge

Fast-charge or CC regulation is active when the battery voltage is above  $VT_{PreQ}$  and less than  $V_{CV}$ , the final float charge voltage of the battery. The fast-charge current can be set to a maximum of 1.5A and is selected by the program resistor on the IPRGM pin. The voltage on this pin represents the current through the battery. It enables a microprocessor via an Analog-to-Digital Converter (ADC) to monitor battery current by sensing the voltage



## Applications Information (continued)

on the IPRGM pin. The fast-charge current is given by the following equations.

$$I_{FQ} = \frac{1.5}{R_{IPRGM}} \times 1000 \quad (\text{SC802})$$

$$I_{FQ} = \frac{1.5}{R_{IPRGM}} \times 1000 - 0.3 \times I_{TERM} \quad (\text{SC802A})$$

Note that for a given program resistor the current through the battery in CV regulation can be determined by replacing 1.5 with the actual voltage on the IPRGM pin in the equations. In the case of the SC802A, the  $I_{TERM}$  term applies only prior to termination (while CHRGB is low), and should be excluded following termination. The CC current can also be modified by applying an analog voltage to the AFC pin as described in the next section.

### Analog Fast-Charge

Many applications require more than one current setting for fast-charge. This feature is included in the SC802/A by using the AFC function. When the AFC pin is connected to VCC the SC802/A operates as described in the previous section. When the AFC pin is driven by an analog voltage between 0 and 1.5V the SC802/A automatically uses this pin voltage to set the maximum fast-charge current setting according to the following equation.

$$I_{AFQ} = \frac{V_{AFC}}{R_{IPRGM}} \times 1000 \quad (\text{SC802})$$

$$I_{AFQ} = \frac{V_{AFC}}{R_{IPRGM}} \times 1000 - 0.3 \times I_{TERM} \quad (\text{SC802A})$$

### Monitor State

When a charge cycle is completed, the SC802/A output turns off and the device enters monitor state. If the voltage of the battery falls below the re-charge voltage of  $V_{CV} - VT_{ReQ}$ , nominally 100mV below  $V_{CV}$ , the charger will clear the charge timer and re-initiate a charge cycle. The maximum current drain from the battery during monitor state is less than 1µA over temperature. The status of the charger output as a function of BIPB, timer status, and  $I_{VOUT}$  in the following table.

Output State	BIPB	Timer	$I_{VOUT}$
On	High	N/A	N/A
On	Low	$t < T_{QCOMP}$	N/A
Off	Low	$t > T_{QCOMP}$	N/A
Off	Low	Disabled	$< I_{TERM}$

### Charge Timer

The timer in the SC802/A provides protection in the event of a faulty battery, and maximizes charging capacity. Connect the RTIME pin to VCC to select the internally programmed timer, and to GND to disable the timer. Connecting a resistor between the RTIME pin and GND will program the total charge complete time  $T_{QCOMP}$  according to the following equation.

$$R_{RTIME} \text{ (k}\Omega\text{)} = T_{QCOMP} \text{ (hours)} \times 12.5 \text{ (k}\Omega\text{/hour)}$$

The timer is programmable over the range of two to six hours. The internal timer selection provides a charge time of three hours. The SC802/A automatically turns off the output when the charge timer times out, and then enters the Monitor State. A re-charge cycle resets and restarts the timer.

Note that the CHRGB fault indication blink rate is a function of the timer setting, whether externally programmed or set internally. When the timer is disabled, the blink rate is the same as if the timer were internally set.

### EN\_NTC Interface

The EN\_NTC pin is the interface to a battery pack temperature sensing Negative Temperature Coefficient (NTC) thermistor. It can be used to suspend charging if the battery pack temperature is outside of a safe-to-charge range. The EN\_NTC interface also serves as a charger disable or NTC-unconditional enable input.

The recommended EN\_NTC network is a fixed-value pullup resistor (designated  $R_{NPU}$ ) from the EN\_NTC pin to the VCC pins, and the battery pack NTC thermistor (designated  $R_{NTC}$ ) from the EN\_NTC pin to ground. In this configuration, shown in the Typical Application Circuit on

## Applications Information (continued)

page 1, an increasing battery temperature produces a decreasing NTC pin voltage, designated  $V_{EN\_NTC}$ .

When  $V_{EN\_NTC}$  is greater than the high (cold) threshold (but below the Charger Enable threshold) or less than the low (hot) threshold (but above the Disable threshold), the charge cycle is suspended, turning off the output. This suspends but does not reset the charge timer, and indicates a charging fault by blinking the CHRGB status indicator. Hysteresis is provided for both high and low NTC thresholds to avoid chatter at the NTC temperature fault thresholds. When  $V_{EN\_NTC}$  returns to the Temperature-OK-to-Charge range, the charge timer resumes, CHRGB is asserted (pulled low), the charging output is enabled, and the charge cycle continues. The timer will expire when the output on-time exceeds the timer setting, regardless of how long it has been disabled due to an NTC fault.

All  $EN\_NTC$  input thresholds are proportional to the VCC pin voltage ( $V_{VCC}$ ). When the recommended external NTC circuit is used, the external  $EN\_NTC$  pin voltage is also proportional to  $V_{VCC}$ , varying with the thermistor resistance. This ensures that all  $EN\_NTC$  thresholds are insensitive to  $V_{VCC}$ . The ratiometric hot and cold thresholds are given by the parameters  $RT_{NTC\_HF}$  and  $RT_{NTC\_CR} \cdot V_{EN\_NTC}$  between  $RT_{NTC\_HF} \times V_{VCC}$  and  $RT_{NTC\_CR} \times V_{VCC}$  indicates the battery temperature is safe to charge, and enables charging. See the following table.

**EN\_NTC Pin Ratiometric Thresholds**

	% of $V_{VCC}$	Range
<b><math>V_{EN\_NTC}</math> Ratiometric Thresholds</b>	$RT_{NTC\_EN} = 90\%$	Charger Enable
	$RT_{NTC\_CR} = 75\%$	NTC Cold Fault
	$RT_{NTC\_HF} = 30\%$	NTC Temperature-OK-to-Charge
		NTC Hot Fault
	$RT_{NTC\_DIS} = 1V$	Charger Disable

When  $V_{EN\_NTC} < 1V$  approximately, the SC802/A charger is disabled. This allows the system controller to asynchronously disable or reset the device by pulling  $EN\_NTC$  to ground, using for example an n-channel FET. When disabled, the charger is turned off, the charge timer is reset,

and CHRGB is turned off (high). The behavior of CPB differs between the SC802 and SC802A when the device is disabled. See the Status Indicators section.

Charger Enable is selected when the battery (along with the thermistor) is removed, determined by the NTC pin exceeding  $RT_{NTC\_EN} \times V_{VCC}$ , nominally 90% of the VCC pin voltage. Charger Enable behaves identically to NTC safe-to-charge. Charger Enable also provides a convenient means to operate the SC802/A in applications without a battery thermistor, without requiring a passive resistor network to obtain 50% of  $V_{VCC}$ . Connect  $EN\_NTC$  directly to VCC, or via a pullup resistor if it will be necessary to disable the charger by pulling  $EN\_NTC$  to ground.

The response of the SC802/A to an  $EN\_NTC$  pin voltage above the NTC Cold Fault threshold (but below  $RT_{NTC\_EN}$ ) or below the low NTC Hot Fault threshold (but above  $VT_{NTC\_DIS}$ ) is the same. Therefore the  $EN\_NTC$  network can be configured with the battery pack thermistor between  $EN\_NTC$  and VCC, and a fixed resistor between  $EN\_NTC$  and ground, reversing the designation of the hot and cold thresholds. This configuration may be used to disable the charger when the battery pack is removed.

For detailed design guidance for ratiometric NTC interfaces, including thermistor selection guidelines, see the Semtech Application Note AN-PM-0801, *NTC Thermistor Network Design for Ratiometric Thresholds*.

### Status Indicators

There are two status indicator outputs on the SC802/A — CHRGB (Charge) and CPB (Charger Present). These outputs are open drain n-channel MOSFET drivers suitable for driving LEDs directly. The following table defines each output state.

**Applications Information (continued)**

Status Indicator	ON (active low)	OFF (inactive high)	Blinking
CPB	UVLO < $V_{VCC}$ < OVP	Power Not Good	X
CHRGB	$I_{OUT} > I_{TERM}$	$I_{OUT} < I_{TERM}^{(1)}$	Pre-charge or NTC fault

(1) Output remains on when timer is enabled and  $t < T_{QCOMP}$

The CPB output can be used as a VCC-valid detector. When  $V_{VCC}$  is between the UVLO and OVP thresholds the CPB output is low. In the SC802, the CPB output reflects the voltage of the VCC input regardless of the voltage  $V_{EN\_NTC}$ . In the SC802A, the CPB output becomes inactive (high) when the charger is disabled, regardless of  $V_{VCC}$ .

The CHRGB output signifies the charging status. When  $I_{VOUT} > I_{TERM}$ , CHRGB is driven low. CHRGB is high when  $I_{VOUT} < I_{TERM}$ . The CHRGB output is latched during the charge cycle when the output current is less than  $I_{TERM}$ . This latch is reset when the battery enters a re-charge cycle, or if BIPB, EN\_NTC, or VCC are toggled. The CHRGB indicator operates the same way in both charging and LDO modes.

The five fault conditions detected by the SC802/A are input under-voltage, input over-voltage, NTC temperature fault, maximum die over-temperature (OT) fault, and pre-

charge timeout. The status indicator states for these fault conditions are shown in the following table.

Fault	CPB	CHRB
VCC UVLO or VCC OVP	OFF	OFF
NTC Fault	ON	Blinking
Pre-Charge Time-out	ON	Blinking
$T_J > 150^\circ\text{C}$	OFF	OFF

**Configuring the Output Voltage to the Battery**
 **$V_{CV}$  Fixed Mode**

The battery voltage is set by the VPRGM pin in fixed mode and externally in the adjust mode. If VPRGM is logic high the output voltage is set to 4.2V. If this pin is logic low the output voltage will be set to 4.1V. For a value other than 4.1V or 4.2V a resistor divider is required.

 **$V_{CV}$  Adjust Mode**

$V_{CV}$  Adjust Mode permits configuring the SC802/A for  $V_{CV}$  other than 4.1V or 4.2V. In  $V_{CV}$  Adjust Mode the CV regulation voltage is set by an external resistor divider. The SC802/A Adjust Mode schematic is shown in Figure 1. The SC802/A provides the capability, via the VPRGM pin, to disconnect the external feedback resistor divider when the charging source is removed, to reduce current drain from the battery through the resistor network. Connect the external resistor divider between the VOUT pins and

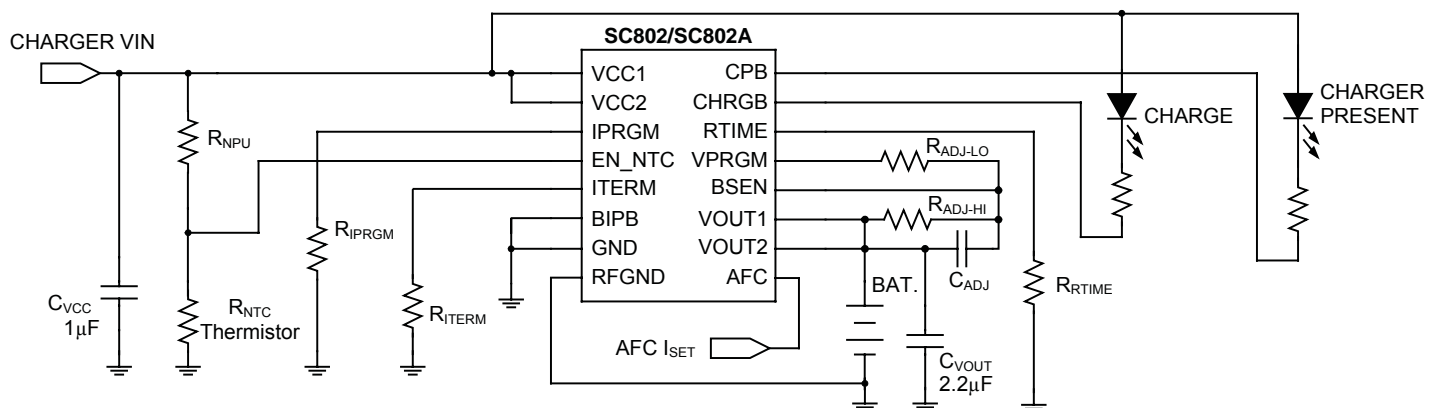

Figure 1.  $V_{CV}$  Adjust Mode programming.

## Applications Information (continued)

the VPRGM pin with the divider tap connected to the BSEN pin to utilize this feature. The Adjust Mode CV regulation voltage is set by the following equation.

$$V_{CV-ADJ} = \left( 1 + \frac{R_{ADJ-HI}}{R_{ADJ-LO}} \right) \times 3.0$$

To ensure detection of  $V_{CV}$  Adjust Mode,  $R_{ADJ-HI}$  should be at least 130k $\Omega$ . The capacitor across  $R_{ADJ-HI}$  in the feedback network provides zero-pole frequency compensation for stability. Place the zero according to the following equation to ensure stability.

$$R_{ADJ-HI} \times C_{ADJ} = \frac{1}{2\pi \times 100\text{kHz}}$$

In  $V_{CV}$  Adjust Mode,  $V_{CV-ADJ}$  must satisfy  $V_{VCC} > V_{CV-ADJ} + 150\text{mV}$  to ensure regulation. If  $V_{VCC}$  approaches  $V_{CV-ADJ}$ ,  $V_{CV-ADJ}$  will drop out such that  $V_{CV-ADJ}$  will be approximately  $V_{VCC} - 150\text{mV}$ .

### LDO Mode

The SC802/A can operate with or without a battery. If the battery is not in place the device can enter LDO Mode. The input pin BIPB is used to switch the SC802/A from charger mode to LDO mode. If this pin is driven logic high the device will be in LDO mode, if it is logic low it will be in the charger mode. The BIPB pin should never be left floating. It should be tied through pull-up or pull-down resistors when connected to a high impedance control pin or it can be connected directly to the VCC pin or GND.

In LDO Mode the SC802/A will function as a low dropout voltage regulator. The EN\_NTC pin functions remain active, and the status indicators are active, including the CHRGB indicator. The timer is inactive. The output remains enabled even when  $I_{VOUT} < I_{TERM}$ . The output voltage can be set to 4.1V, 4.2V or externally set by a resistor divider, with a current limit equal to  $I_{FQ}$ . The pre-charge threshold is ignored.

### Remote Kelvin Sensing at the Battery

Kelvin sensing of both the positive and negative terminals of the battery is available on the SC802/A. The BSEN pin provides the positive sensing voltage feedback to the CV amplifier and should be connected as close to the battery

positive terminal as possible. The REFGND pin should be Kelvin connected to the negative terminal of the battery. This provides maximum flexibility in PCB layout. This also results in a greater accuracy in sensing the battery voltage at the battery terminals. When laying out the PCB the designer should route the BSEN pin directly to the battery terminal connections. (For Adjust Mode, the high-side resistor should be connected directly to the battery terminal connections.) In LDO mode, as in Charging mode, the BSEN pin must sense the output voltage, so BSEN should never be left unconnected.

### Over-Current and Max Temperature Protection

Over-current protection is inherent in all modes of operation. When the device is in charge-mode (BIPB=low) the output is current limited to either the pre-charge current limit value or the fast-charge current limit value depending on  $V_{VOUT}$ . When the device is in LDO mode (BIPB = high) the output current is limited to the fast-charge current limit. Maximum die temperature protection is provided on the SC802/A. This feature allows the SC802/A to operate with maximum power dissipation by disabling the output current when the die temperature reaches the over temperature limit. The device will then operate as a pulse charger in extreme power dissipation applications, delivering the maximum allowable output current while regulating the internal die temperature to a safe level.

### Capacitor Selection

Low cost, low ESR ceramic capacitors such as the X5R and X7R dielectric material types are recommended. The VOUT pin capacitance range is typically 1 $\mu\text{F}$  to 4.7 $\mu\text{F}$ , but  $C_{VOUT}$  can be as large as desired to accommodate the required input capacitors of regulators connected directly to the battery terminal. The VCC pin input capacitor  $C_{VCC}$  is typically between 0.1 $\mu\text{F}$  to 1 $\mu\text{F}$ , but larger values will not degrade performance. Capacitance must be evaluated at the expected bias voltage ( $V_{CV}$  for  $C_{VOUT}$ , the expected VCC supply regulation voltage for  $C_{VCC}$ ), rather than the zero-volt capacitance rating.

State Diagram

Over Voltage or Under Voltage will disable (and reset) the SC802/A, regardless of charger state. Over Temperature will turn off output but preserve charger state.

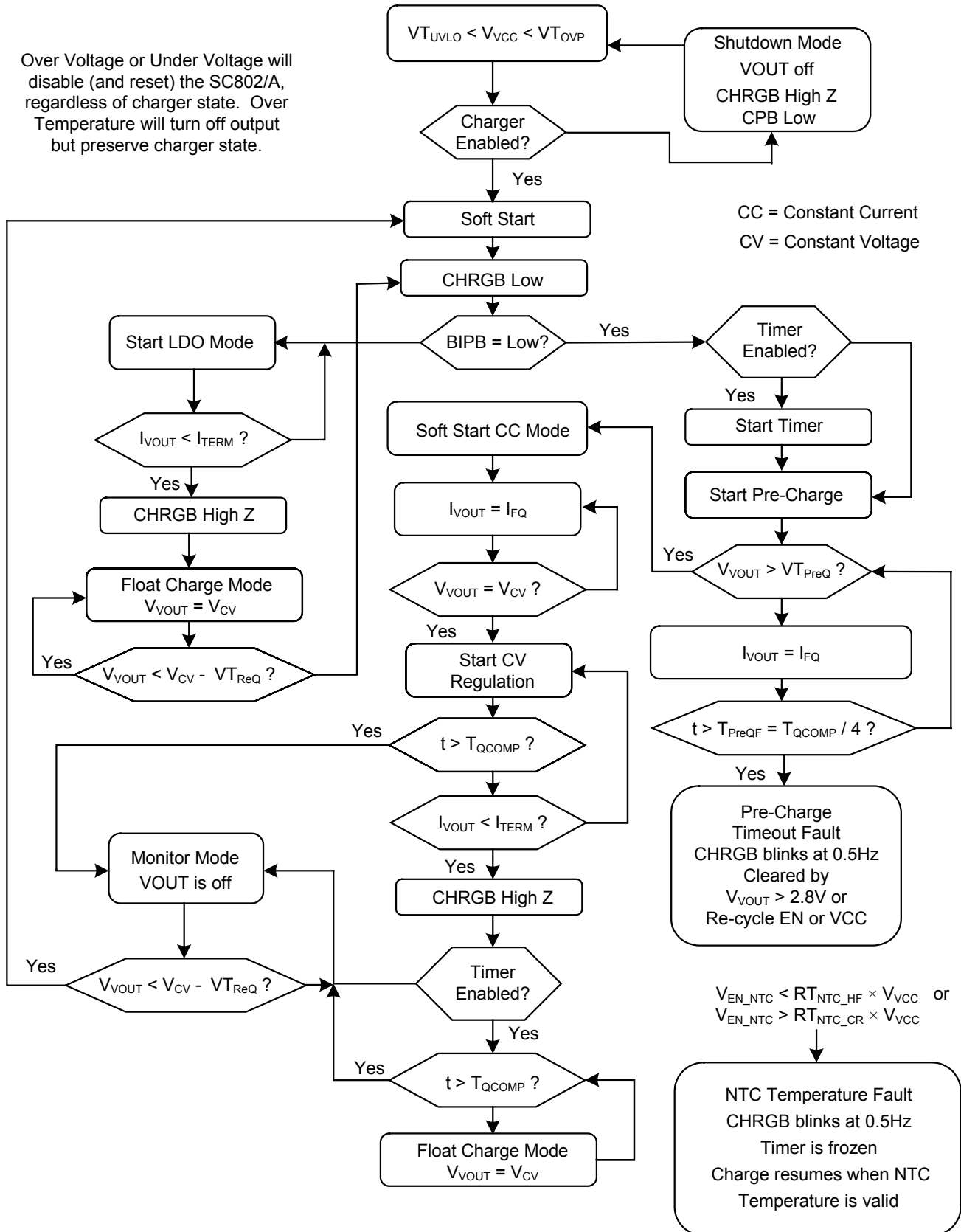

### Charge Mode Timing Diagram

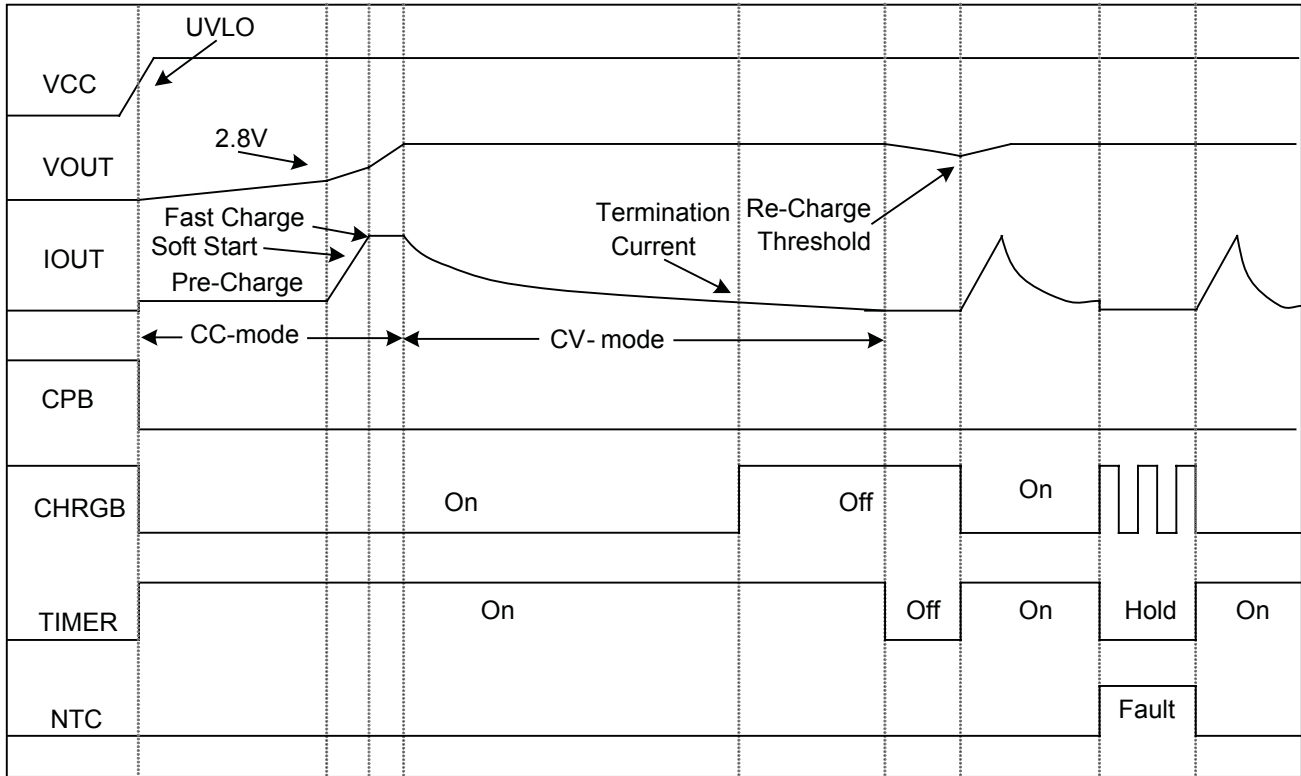

### LDO Mode Timing Diagram

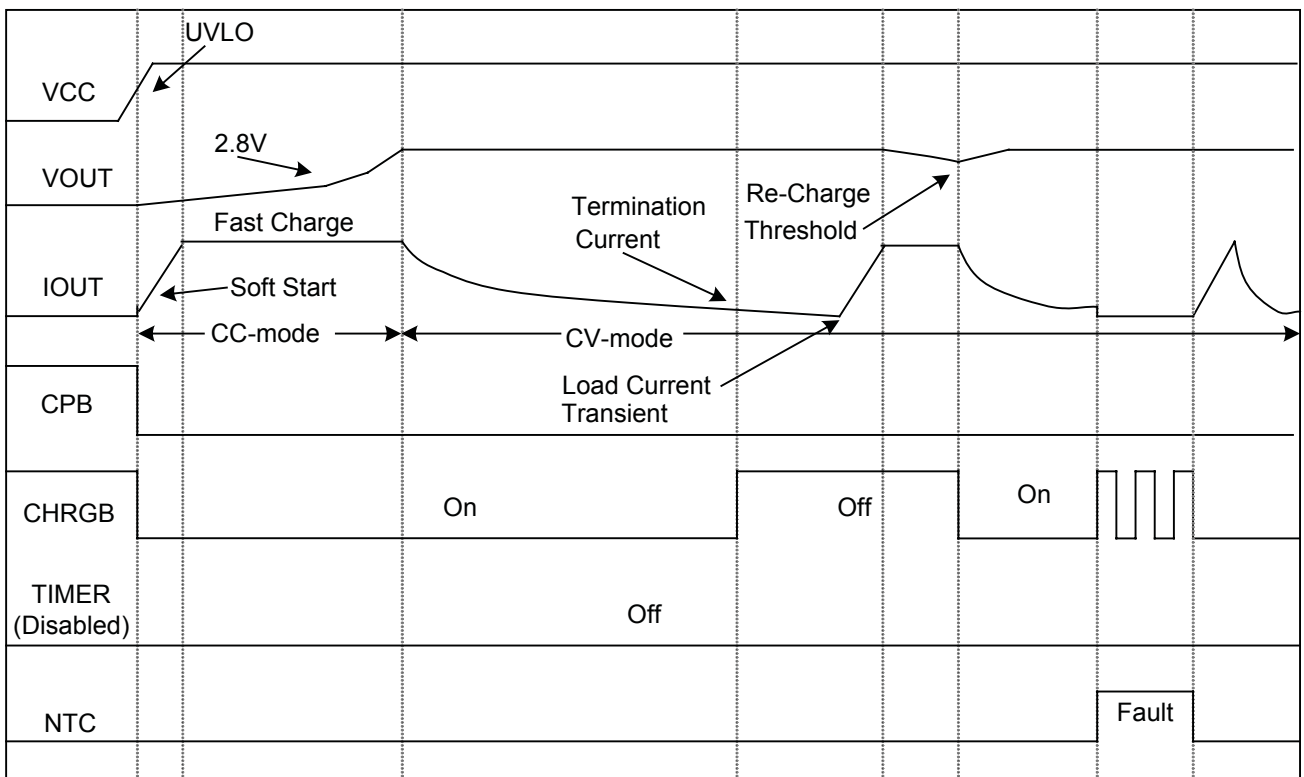



**Evaluation Board Schematic**

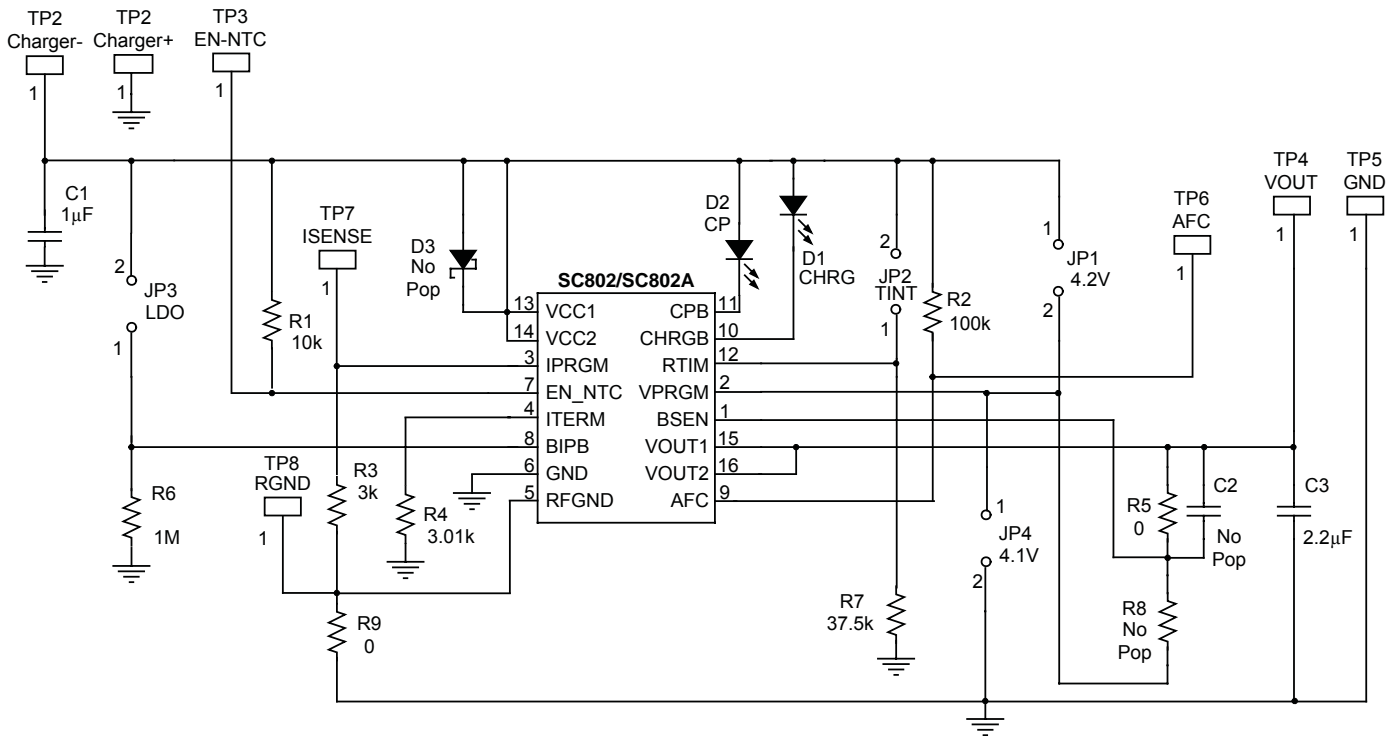

Outline Drawing — MLPQ-16 (4×4×0.9mm)

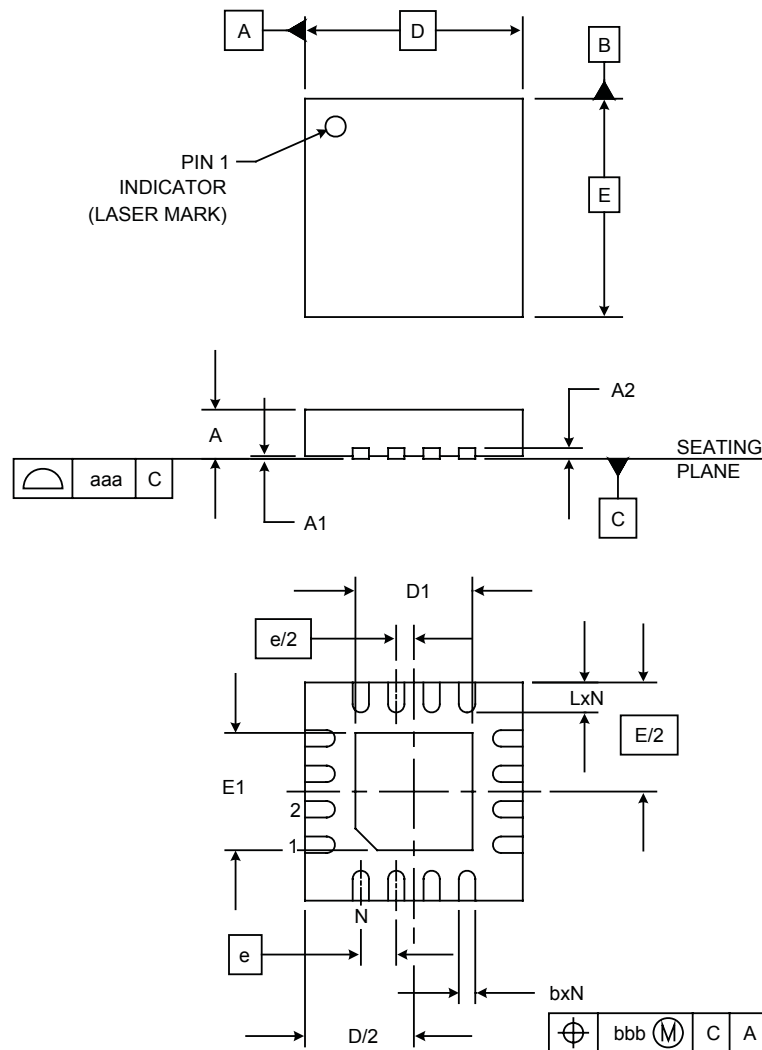

DIM	DIMENSIONS					
	INCHES			MILLIMETERS		
	MIN	NOM	MAX	MIN	NOM	MAX
A	.031	-	.039	0.80	-	1.00
A1	.000	-	.002	0.00	-	0.05
A2	-	(.008)	-	-	(0.20)	-
b	.010	.012	.014	0.25	0.30	0.35
D	.154	.157	.161	3.90	4.00	4.10
D1	.079	.085	.089	2.00	2.15	2.25
E	.154	.157	.161	3.90	4.00	4.10
E1	.079	.085	.089	2.00	2.15	2.25
e	.026 BSC			0.65 BSC		
L	.018	.022	.026	0.45	0.55	0.65
N	16			16		
aaa	.003			0.08		
bbb	.004			0.10		

NOTES:

1. CONTROLLING DIMENSIONS ARE IN MILLIMETERS (ANGLES IN DEGREES).
2. COPLANARITY APPLIES TO THE EXPOSED PAD AS WELL AS THE TERMINALS.



Outline Drawing — MLPQ-16 (4x4x0.9mm)

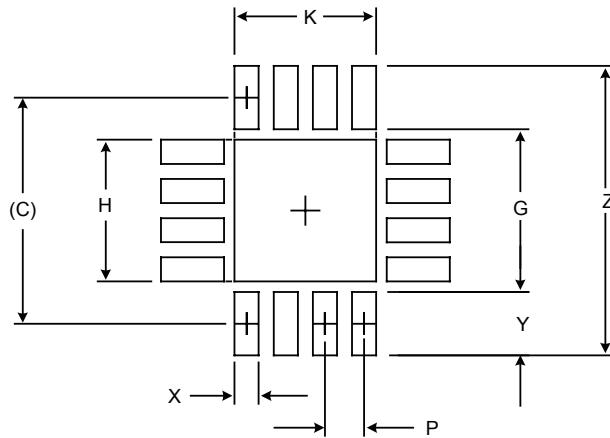

DIMENSIONS		
DIM	INCHES	MILLIMETERS
C	(.148)	(3.75)
G	.106	2.70
H	.091	2.30
K	.091	2.30
P	.026	0.65
X	.016	0.40
Y	.041	1.05
Z	.189	4.80

NOTES:

1. THIS LAND PATTERN IS FOR REFERENCE PURPOSES ONLY. CONSULT YOUR MANUFACTURING GROUP TO ENSURE YOUR COMPANY'S MANUFACTURING GUIDELINES ARE MET.
2. THERMAL VIAS IN THE LAND PATTERN OF THE EXPOSED PAD SHALL BE CONNECTED TO A SYSTEM GROUND PLANE. FAILURE TO DO SO MAY COMPROMISE THE THERMAL AND/OR FUNCTIONAL PERFORMANCE OF THE DEVICE.
3. SQUARE PACKAGE - DIMENSIONS APPLY IN BOTH " X " AND " Y " DIRECTIONS.

Contact Information

Taiwan  
Tel: 886-2-2748-3380  
Fax: 886-2-2748-3390

Switzerland  
Tel: 41-32-729-4000  
Fax: 41-32-729-4001

Korea  
Tel: 82-2-527-4377  
Fax: 82-2-527-4376

United Kingdom  
Tel: 44-1794-527-600  
Fax: 44-1794-527-601

Shanghai  
Tel: 86-21-6391-0830  
Fax: 86-21-6391-0831

France  
Tel: 33-(0)169-28-22-00  
Fax: 33-(0)169-28-12-98

Japan  
Tel: 81-3-6408-0950  
Fax: 81-3-6408-0951

Germany  
Tel: 49-(0)8161-140-123  
Fax: 49-(0)8161-140-124

# Mouser Electronics

Authorized Distributor

Click to View Pricing, Inventory, Delivery & Lifecycle Information:

[Semtech:](#)

[SC802AIMLTRT](#) [SC802IMLTRT](#)