

CCM03 MK2 Series

CCM03-3001 LFT / CCM03-3009 LFT

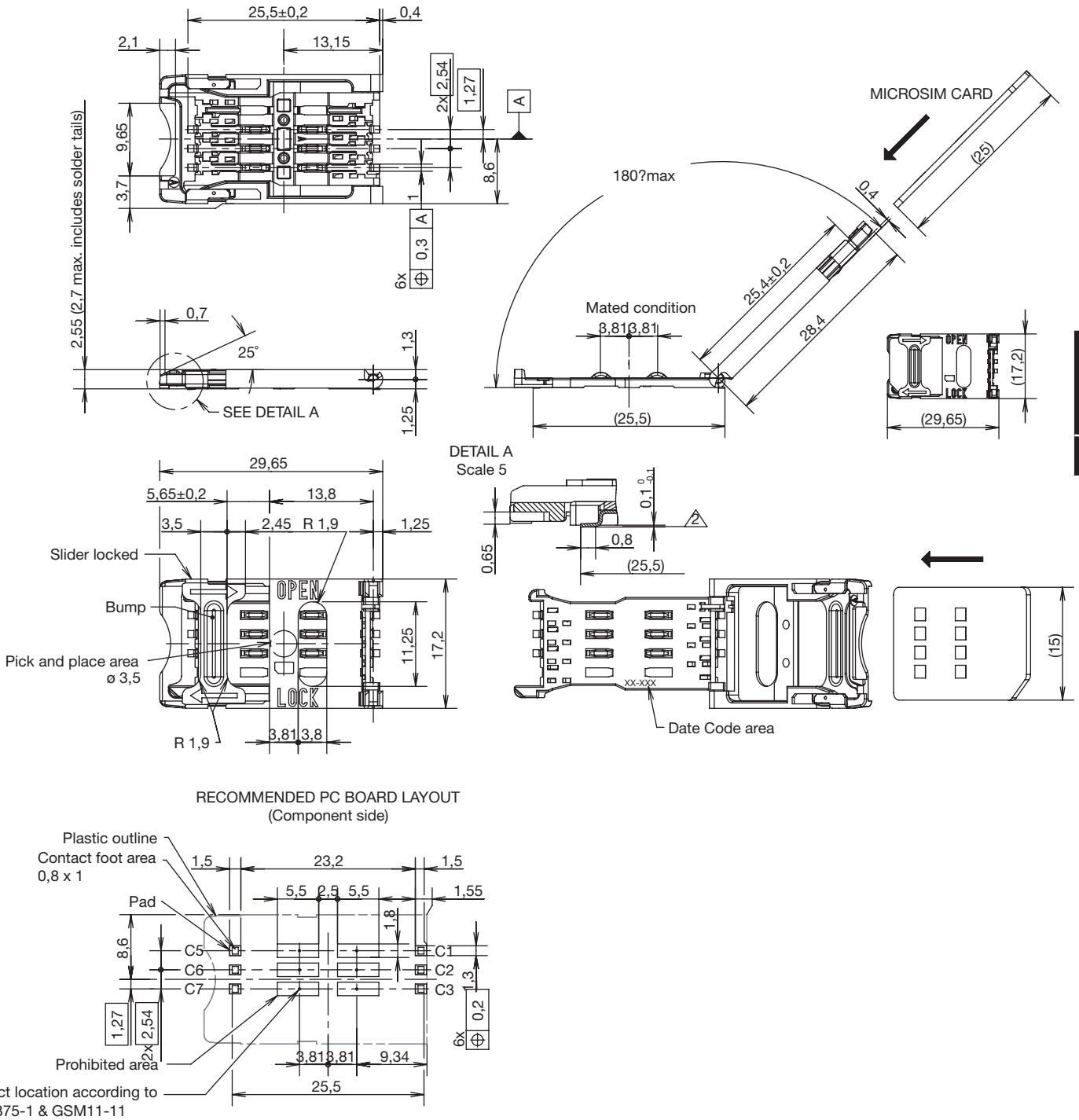

CCM03 MK2 Series

CCM03-3002 LFT / CCM03-3010 LFT

SIM/SAM

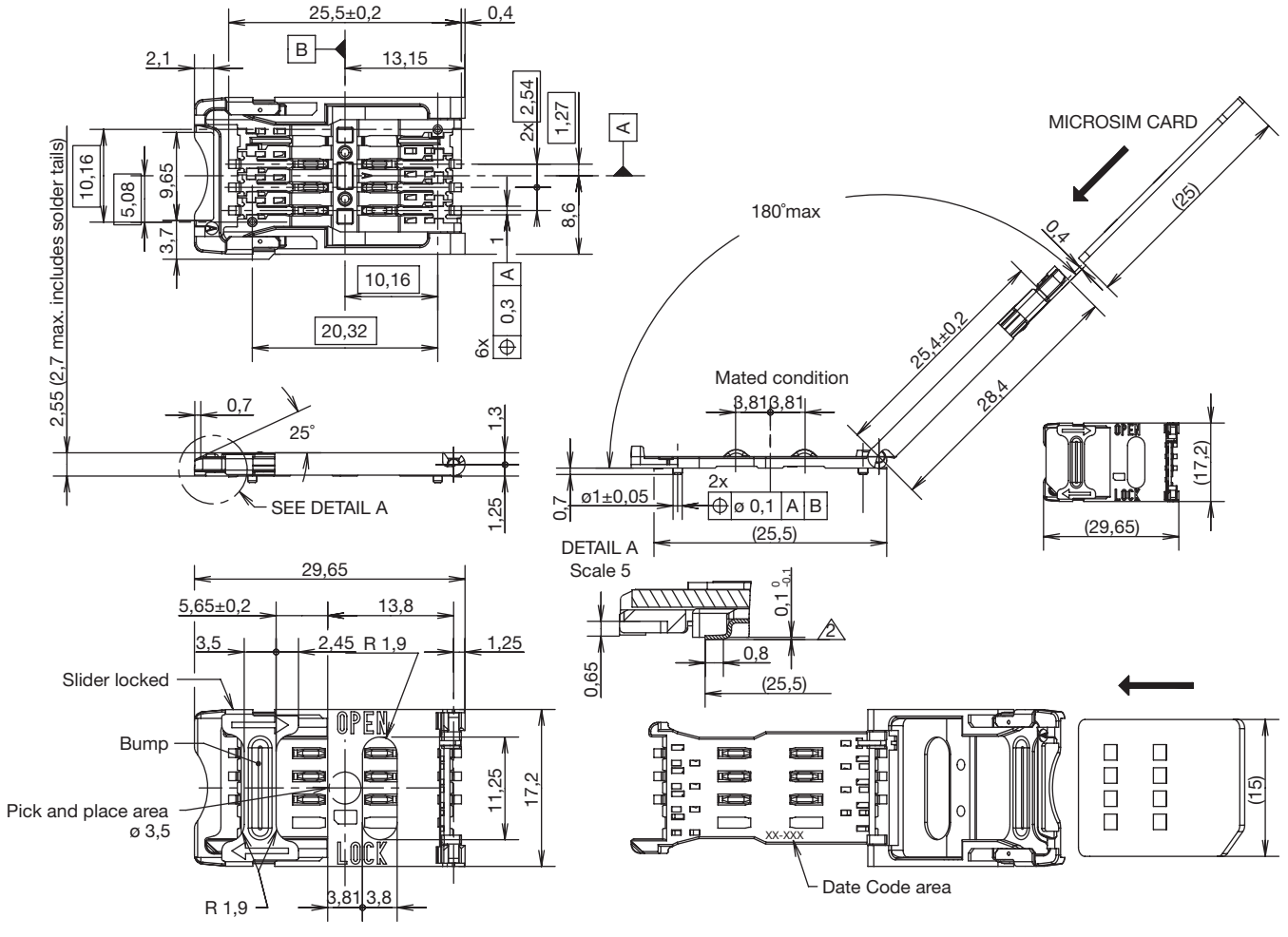

RECOMMENDED PC BOARD LAYOUT
(Component side)

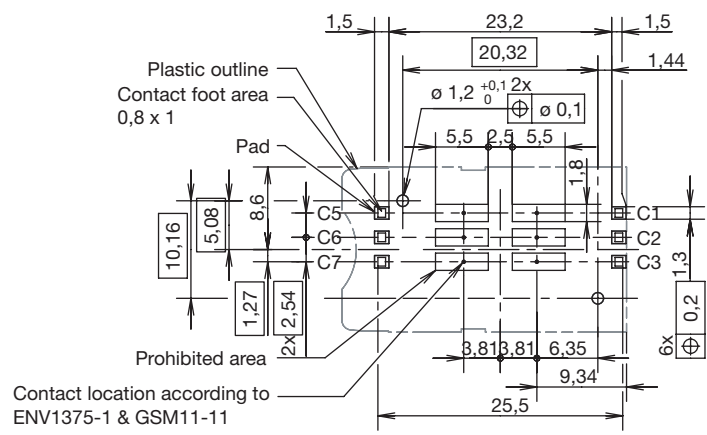

Dimensions are shown in mm
Specifications and dimensions subject to change

www.ckswitches.com

CCM03 MK2 Series

CCM03-3003 LFT

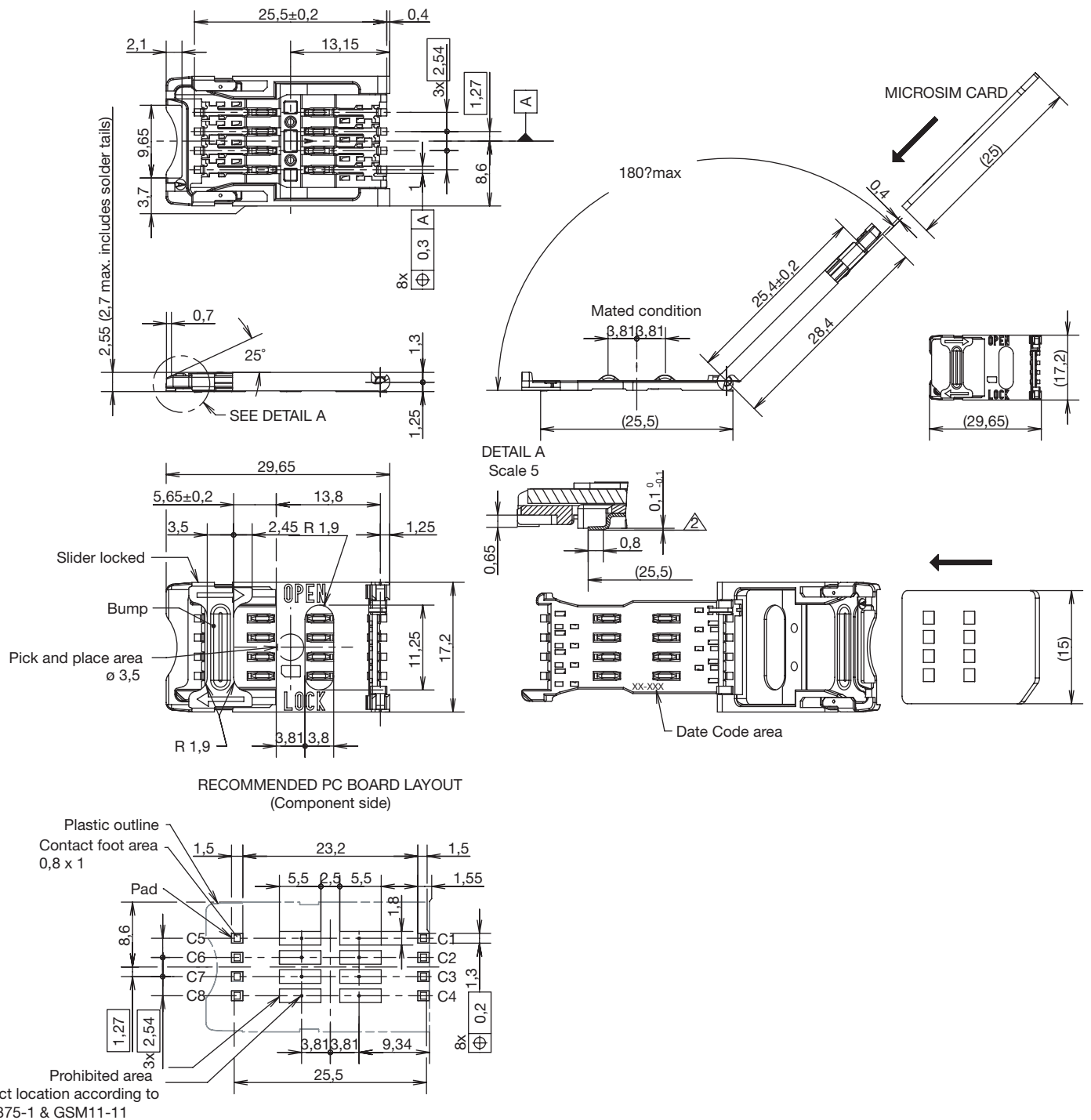

SIM/SAM

CCM03 MK2 Series

CCM03-3004 LFT

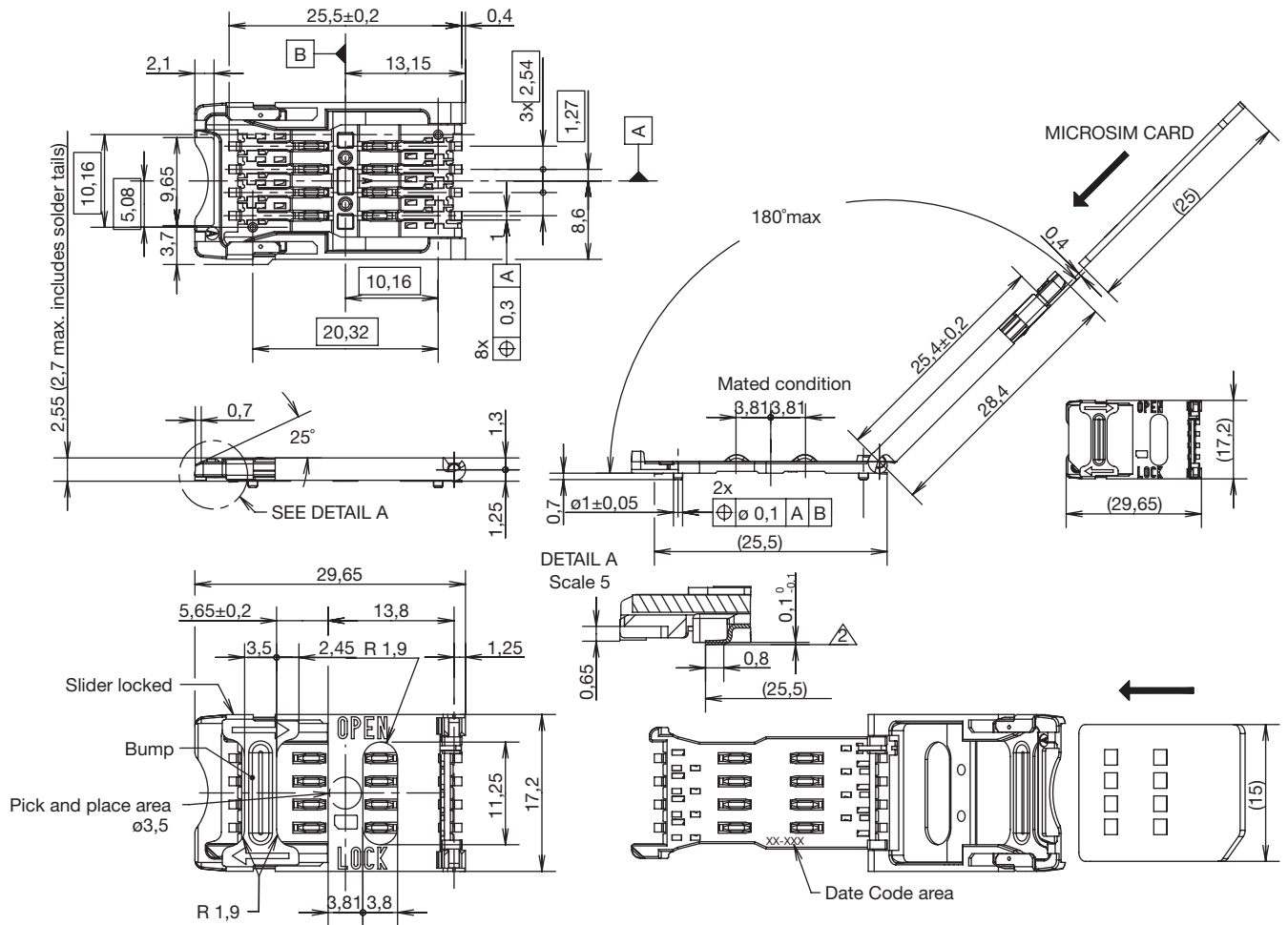

RECOMMENDED PC BOARD LAYOUT
(Component side)

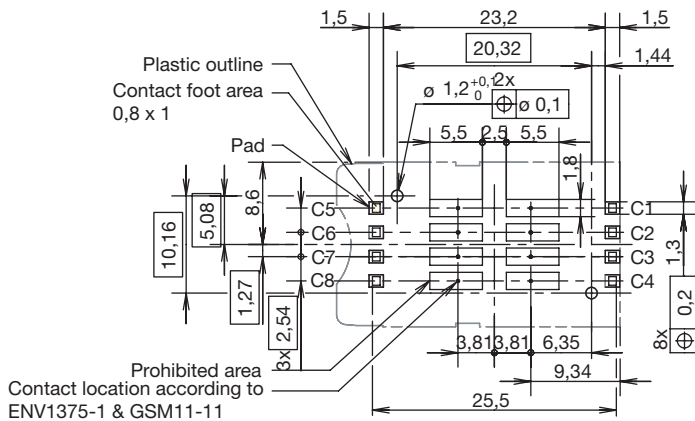

Dimensions are shown in mm
Specifications and dimensions subject to change

www.ckswitches.com

SIM/SAM



10 Mar 21

CCM03 MK2 Series

CCM03-3011 LFT

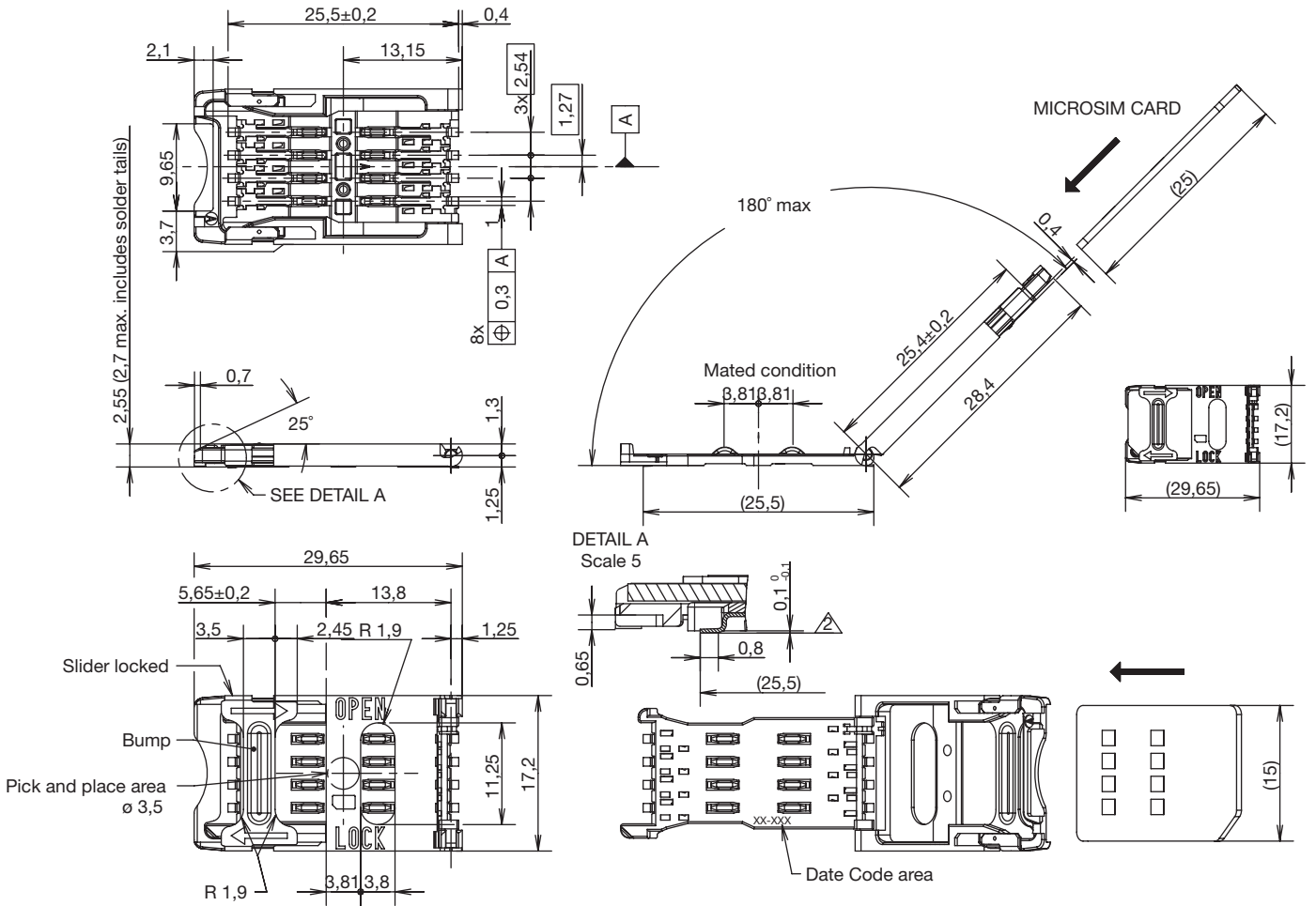

RECOMMENDED PC BOARD LAYOUT (Component side)

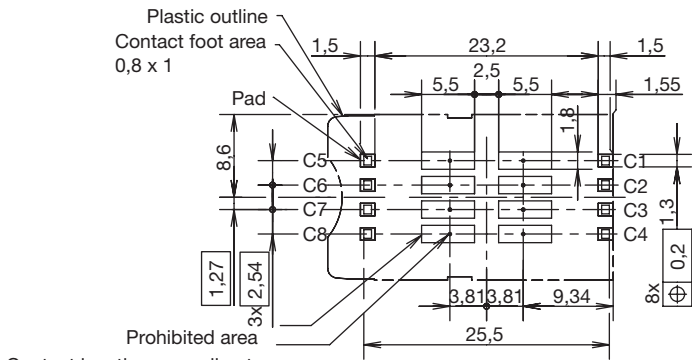

Contact location according to
ENV1375-1 & GSM11-11



10 Mar 21



Dimensions are shown in mm
Specifications and dimensions subject to change

www.ckwitches.com

CCM03 MK2 Series

CCM03-3012 LFT

SIM/SAM

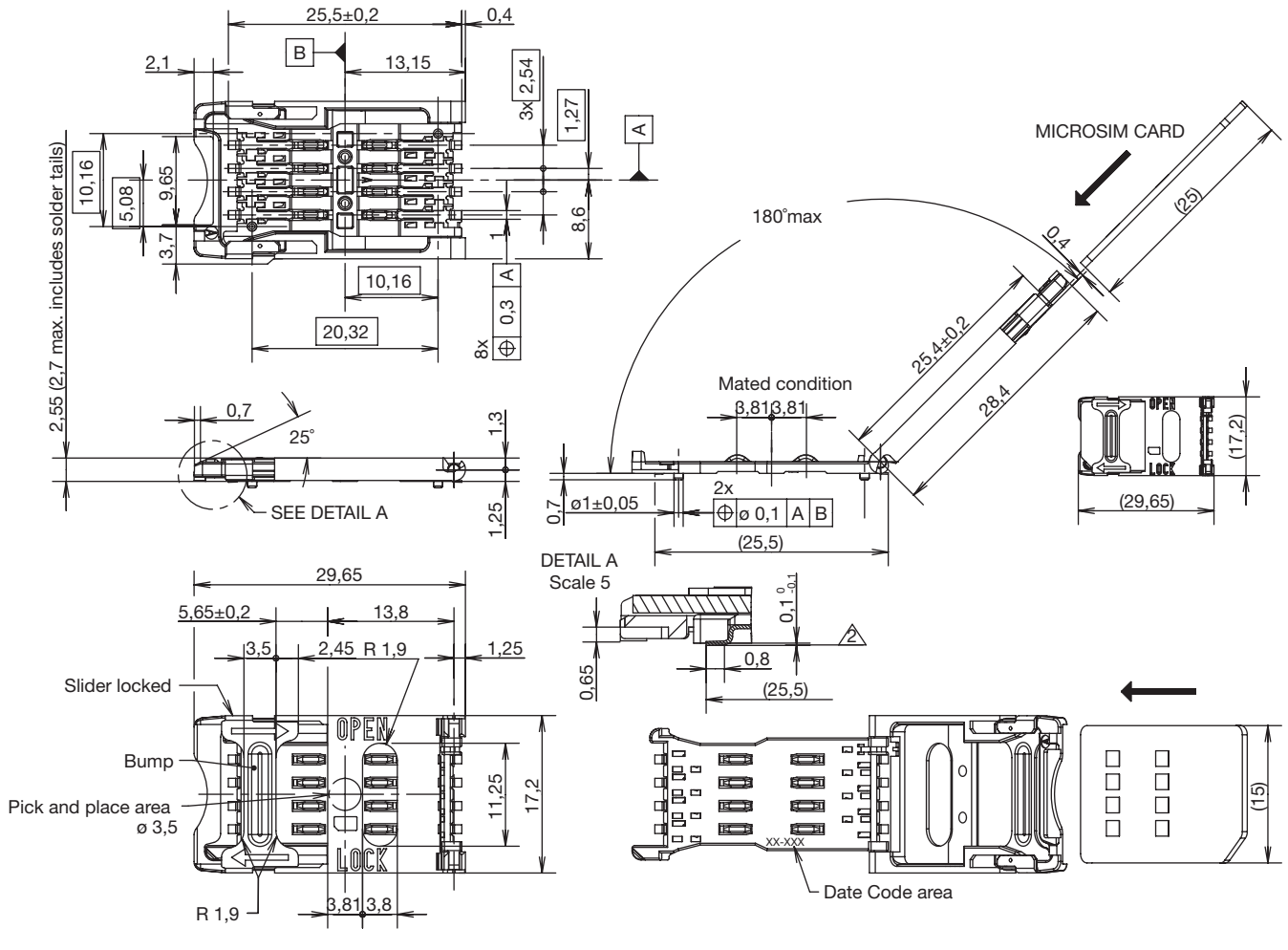

RECOMMENDED PC BOARD LAYOUT
(Component side)

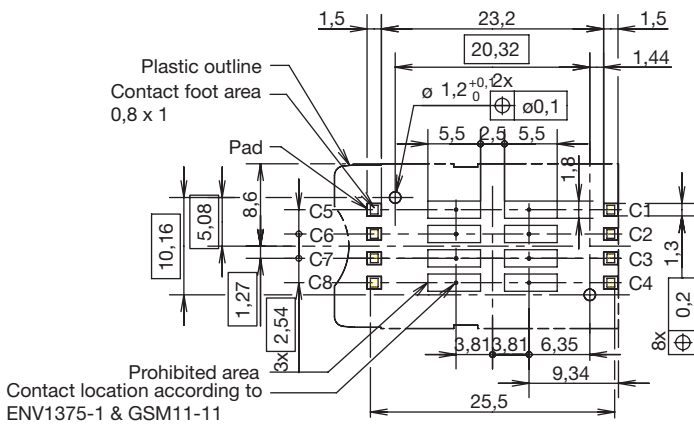

Dimensions are shown in mm
Specifications and dimensions subject to change

www.ckwitches.com



10 Mar 21

CCM03 MK2 Series

CCM03-3013 LFT

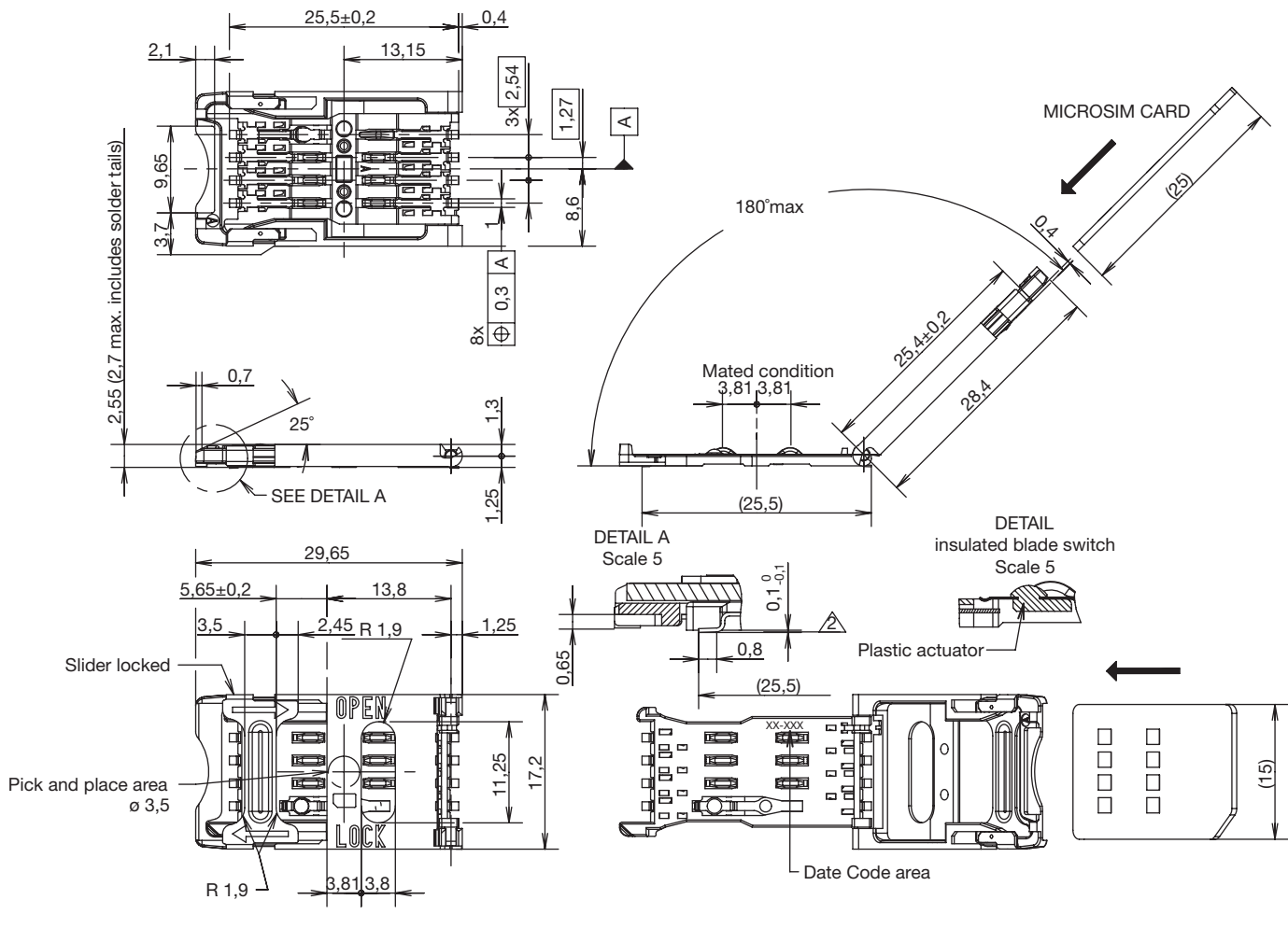

SIM/SAM

RECOMMENDED PC BOARD LAYOUT (Component side)

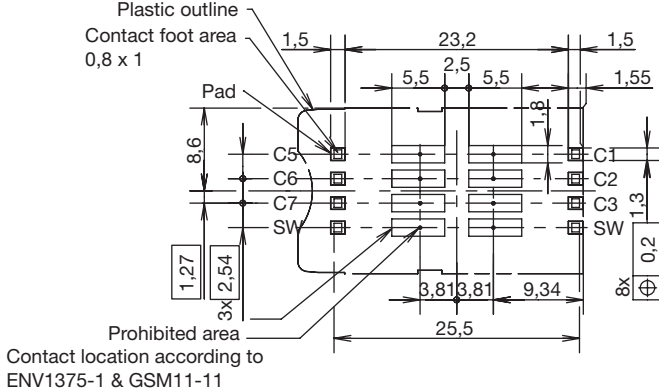

10 Mar 21



Dimensions are shown in mm
Specifications and dimensions subject to change

www.ckwitches.com

CCM03 MK2 Series

CCM03-3512 LFT

SIM/SAM

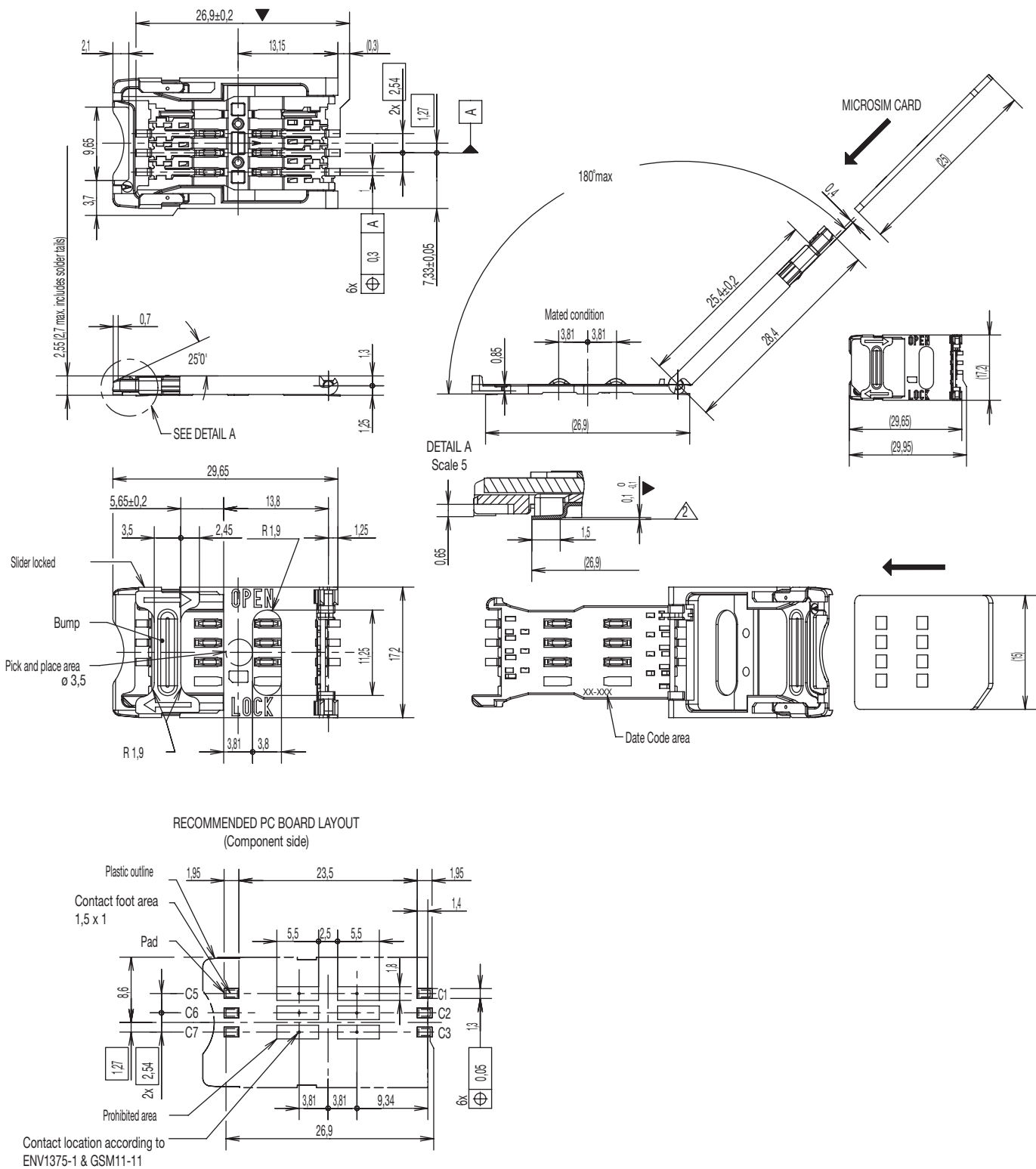

Dimensions are shown in mm
Specifications and dimensions subject to change

www.ckswitches.com



10 Mar 21

CCM03 MK2 Series

CCM03-3504 LFT / CCM03-3505 LFT

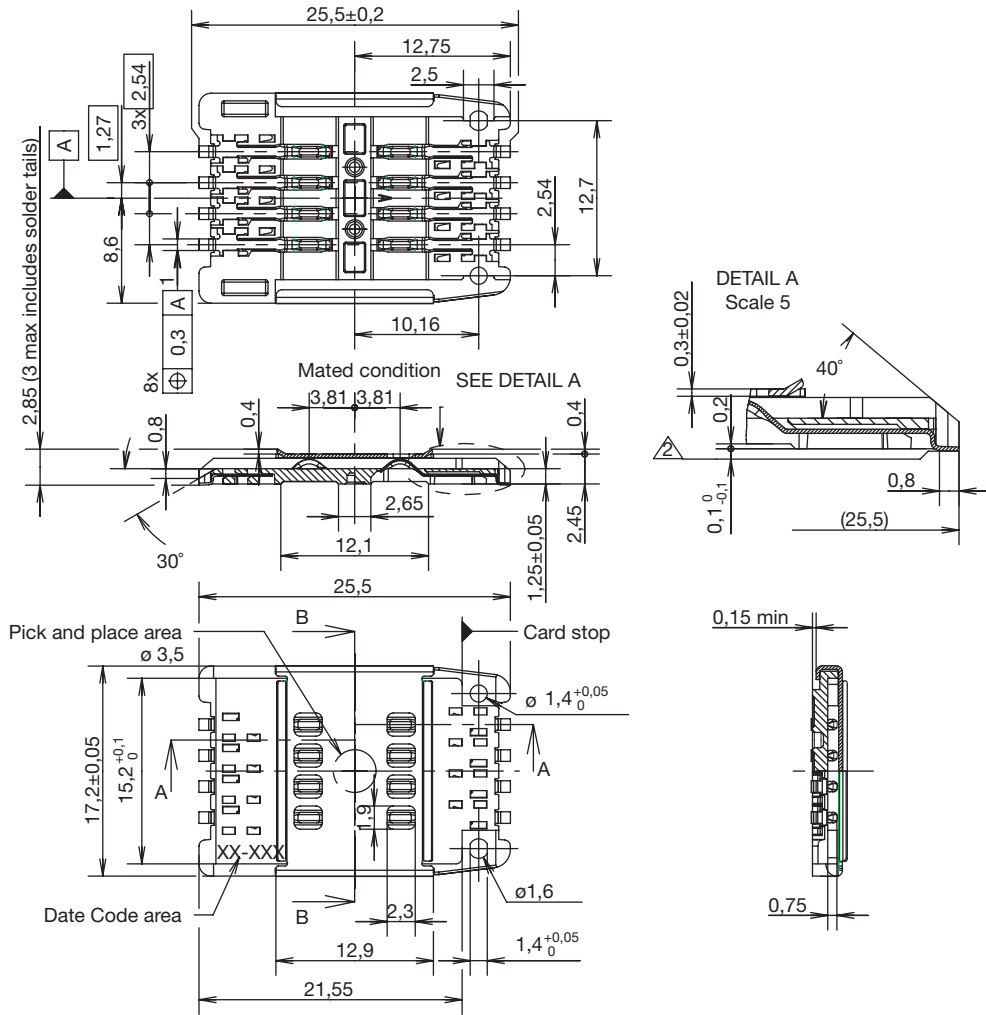

RECOMMENDED PC BOARD LAYOUT (Component side)

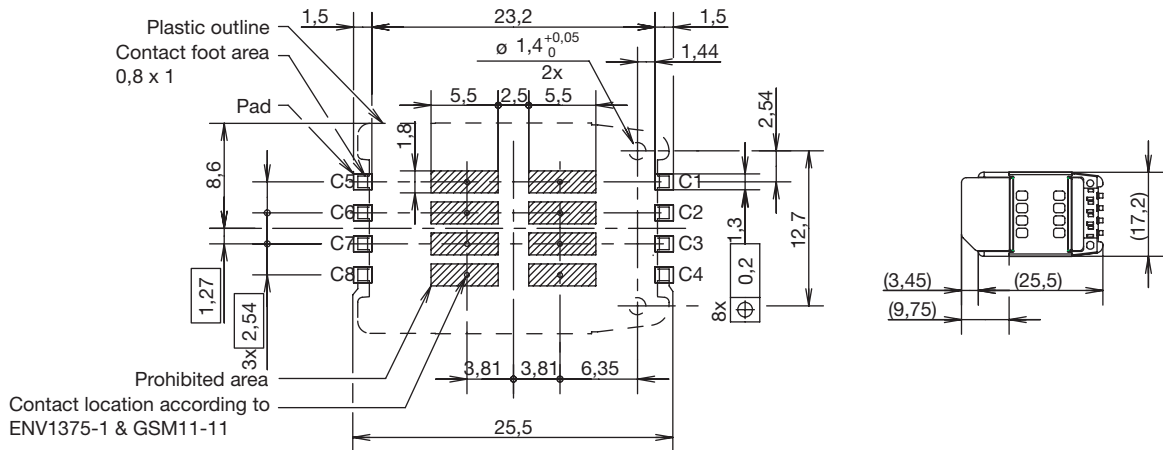

Dimensions are shown in mm
Specifications and dimensions subject to change



10 Mar 21

www.ckswitches.com

Mouser Electronics

Authorized Distributor

Click to View Pricing, Inventory, Delivery & Lifecycle Information:

C&K Switches:

[CCM033001LFTR102](#) [CCM033009LFTR102](#) [CCM033505LFTR122](#) [CCM033754LFTR102](#) [CCM03-3001LFT R102](#)