

# Networking

The network is the foundation of every IT infrastructure. In recent years, major advances in information communication technologies (ICTs), combined with the rapid growth of global networks such as the Internet, have transformed businesses and markets. Enterprises are now investing in new business applications and services that expand the use and reliability of the network and play a critical role in day-to-day operations, creating significant wealth and economic growth in the world. This growth has been made possible by the combination of dramatic increases in the power and versatility of technologies, with significantly reduced costs and creative application of tools and networks in all aspects of the economy and society.



To meet demand for low power while providing a roadmap for next-generation networking applications, Freescale provides excellent features for the market by combining higher CPU performance with enhanced triple-speed Ethernet controllers (eTSEC) supporting SGMII, while the PCI Express, SATA and DDR3/3L interfaces offer versatility and convenience.

Networking applications also enjoy the benefits of software data path acceleration to increase networking performance. A small package (19 mm x 19 mm) and low power consumption will enable a low bill of materials and fanless designs.

## Applications

- Customer premise equipment
- NAS/media server
- Wireless Enterprise AP (802.11n 3 x 3 MIMO)
- Routers
- Switches
- Firewall
- Security appliance
- Voice-over-Internet Protocol
- Multi-service business gateways (e.g., media gateways, IP/PBX-VOIP)

## Features for the Market

- Secure boot
- High-speed line rate GbE networking
- Low-power fanless operation
- Integrated SerDES reduces system interconnect costs (SGMII, PCIe)
- High-performance integration to meet cost and power pressures across Ethernet/ATM/TDM
- TDM for legacy phone interfaces to support voice
- Support for a broad range of third-party embedded OSs
- Long product life cycles

**Triple Play Gateway Block Diagram**

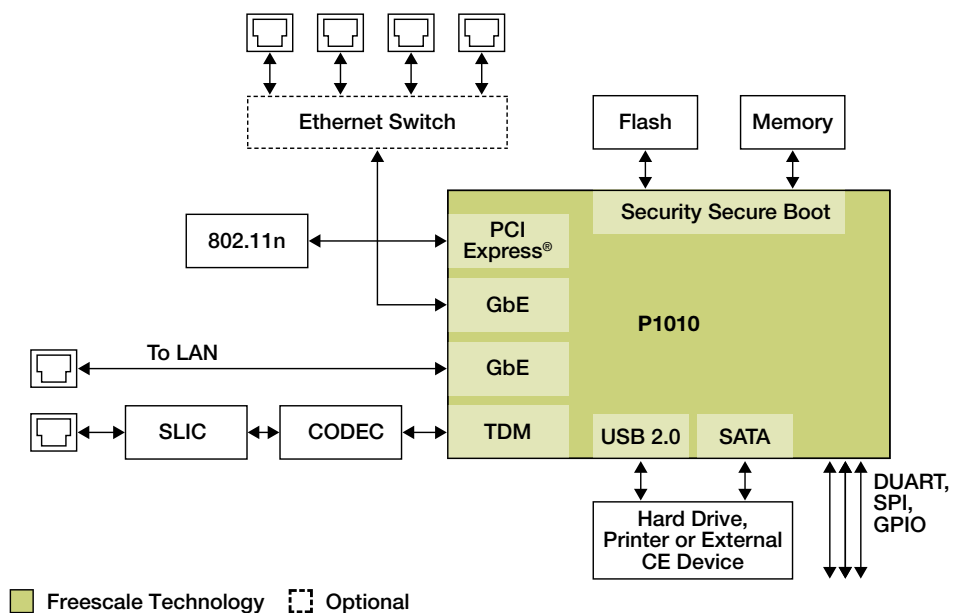

# Wireless Communications

Wireless communications is one of the fastest growing segments of the communications industry and the variety of devices using wireless communications is rising rapidly. As such, it has captured the attention of the media and the imagination of the public. Many new applications, including automated highways and factories, wireless sensor networks, smart homes and appliances and remote telemedicine, are emerging from research ideas to concrete systems. The explosive growth of wireless systems, coupled with the proliferation of laptop and palmtop computers, indicate a bright future for wireless networks both as stand-alone systems and as part of the larger networking infrastructure. However, many technical challenges remain in designing robust wireless networks that deliver the performance necessary to support emerging applications.



Freescale offers a comprehensive portfolio of wireless communications solutions optimized for SOHO, SMB and enterprise WLAN applications. Freescale's investment in performance-optimized, form-factor-complete reference designs provides a starting point for customer development needs, accelerating time to market while significantly reducing overall development costs. These systems demonstrate how a high-performance CPU provides the complete data and control path processing needs for multiple radio solutions while providing excellent throughput with best-in-class performance/watt.

## Applications

- Wireless LAN
- Multi-service business gateways

## Features for the Market

- Low power consumption to meet mobile or home-based device requirements
- Integrated PCI Express interface to support high-performance 802.11n 3 x 3 MIMO WLAN connectivity (>280 Mbps wireless per Wi-Fi® card, dual card, concurrent dual band offers >530 Mbps wireless)
- Cost-effective controller with Gigabit Ethernet and USB integrated to provide a high QoS at a competitive price
- Production strategy software stacks for wireless LAN solutions
- Energy efficient by design

Wireless LAN Router Block Diagram

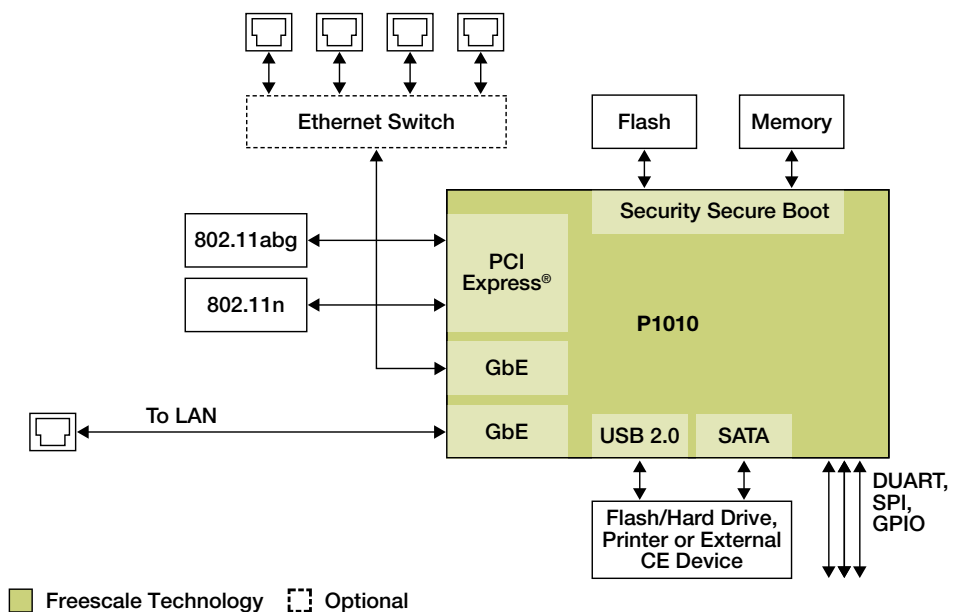

\* Based on MPC8300 running at 266 MHz

# Storage

There was a time when high-speed, high-capacity storage systems were primarily deployed in enterprise environments, now they are increasingly used in small business and home applications. Market drivers include:

- Rapidly increasing volumes of business data that require secure storage, including e-mail, Web content, video and other e-business material
- Government regulations, such as notification and retention policies
- Disaster recovery from power outages, fires and other natural calamities
- Explosive growth in sophisticated home information, communication and entertainment systems



Freescale offers a broad portfolio of embedded processor solutions for these market areas: storage area network (SAN), network-attached storage (NAS), digital video recorder and digital media server (DMS). These solutions range from high-performance host processors to cost-optimized system-on-chip (SoC) architectures with integrated RAID engines and SATA interfaces. In addition, Freescale has ported and optimized useful open source software packages such as the Live555 streaming media server with real-time streaming protocol (RTSP), DLNA and the Openfiler NAS storage protocol suite and GUI to support this platform. P10xx offers an accelerated SEC encryption engine and secure boot for secured NAS. P10xx also offers a generous high-performance L1/L2 cache and DDR3 memory, critical for high-performance NAS, DVR/NVR, media server and multi-service business gateway applications.

## Applications

- Secured NAS (also high-performance wireless NAS)
- Secured DVR/NVR
- Secured media server

## Features for the Market

- Integrated SATA and RAID acceleration
- Low BOM cost
- High levels of SoC integration
- High-speed line rate GbE networking
- High-speed memory
- Advanced energy management
- Low-power fanless operation
- Openfiler NAS and Live555 media server, DLNA

**Network Attached Storage (NAS) Block Diagram**

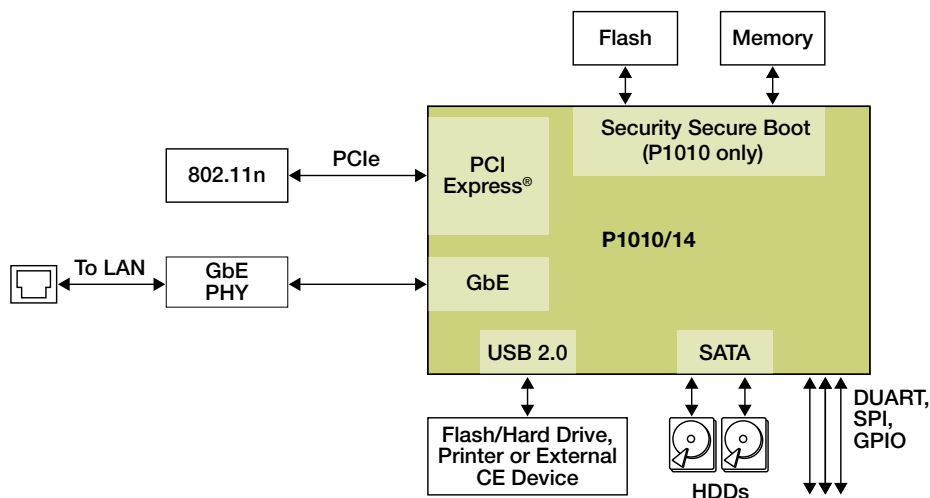

Freescale Technology

# Industrial

In today's industrial market, new technology provides many opportunities for system developers to successfully address ever-evolving challenges. Freescale delivers embedded industrial solutions engineered to meet the environmental, longevity and energy-efficiency requirements of connected industrial applications. We are fulfilling our industrial customers' needs to meet the growing requirements for more intelligent and cost-effective industrial solutions for the industrial control and networking, drives, smart grid, HVAC, security, power and point of sale (POS) markets.

Freescale's P1010/P1014 processors deliver unique product differentiators like trusted architecture for complete code signing and secure boot. Coupled with the integration of industrial interfaces like FlexCAN, support for IEEE® 1588 and quad UARTS in a <3W power envelope provide the ingredients for the most innovative designs in the segment. The P1010/P1014 series provides an ideal stepping off point into the QorIQ family, a true single-core processor. Customers can benefit from increased power savings and a smaller footprint for their industrial designs where cost and power are critical.



## Applications

- Factory automation
- Industrial networking
- Test and measurement
- Telehealth gateway
- Home energy gateway
- Smart grid data concentrator

## Features for the Market

- Low-power, high-performance CPU
- Secure boot, FlexCAN, quad UARTS
- Junction temperature range of -40°C to +105°C
- Optimal BOM and performance design
- Energy-efficient system design
- Long product life cycles
- Broad range of third-party embedded OS supported
- IEEE 1588 for nanosecond time-stamping accuracy

### Industrial Energy Gateway Diagram

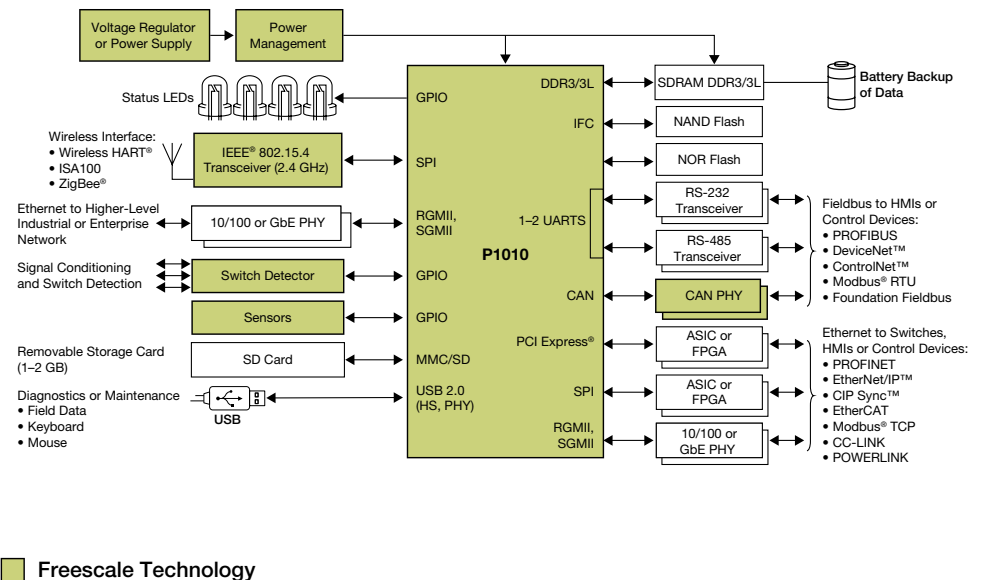

## QorIQ P1010/P1014 Processor Comparison

	P1010	P1014
<b>CPU Frequency (MHz)</b>	533, 667, 800	533, 667, 800
<b>MIPS</b>	1280–1920	1280–1920
<b>Cache (I/D)</b>	32K/32K	32K/32K
<b>Cache L2</b>	256 KB	256 KB
<b>DDR Controller</b>	16/32-bit DDR3/DDR3L w/ECC	16-bit DDR3/DDR3L w/ECC
<b>DDR Data Rate (MHz)</b>	800	800
<b>Integrated Flash Controller</b>	Yes	Yes
<b>PCI Express</b>	2	2
<b>USB + PHY</b>	1 USB 2.0	1 USB 2.0
<b>SATA</b>	2	2
<b>Accelerators</b>	SEC 4.0 with trusted boot	SEC 4.0
<b>GbE</b>	3 x 10/100/1000 SGMII and jumbo frame support	2 x 10/100/1000 SGMII and jumbo frame support
<b>FPU</b>	Double precision	Double precision
<b>DUART</b>	Dual	Dual
<b>I<sup>2</sup>C</b>	Dual	Dual
<b>SPI</b>	Single	Single
<b>Package</b>	425 TEPBGA1	425 TEPBGA1
<b>Estimated Max Power</b>	<3W	<3W
<b>Other</b>	IEEE® 1588, TDM, FlexCAN, SD/MMC and NAND boot options	IEEE 1588, TDM, SD/MMC and NAND boot options

## How to Reach Us:

**Home Page:**  
freescale.com

**QorIQ Information:**  
freescale.com/QorIQ

**Web Support:**  
freescale.com/support

**USA/Europe or Locations Not Listed:**  
Freescale Semiconductor, Inc.  
Technical Information Center, EL516  
2100 East Elliot Road  
Tempe, Arizona 85284  
+1-800-521-6274 or +1-480-768-2130  
www.freescale.com/support

**Europe, Middle East, and Africa:**  
Freescale Halbleiter Deutschland GmbH  
Technical Information Center  
Schatzbogen 7  
81829 Muenchen, Germany  
+44 1296 380 456 (English)  
+46 8 52200080 (English)  
+49 89 92103 559 (German)  
+33 1 69 35 48 48 (French)  
www.freescale.com/support

**Japan:**  
Freescale Semiconductor Japan Ltd.  
Headquarters  
ARCO Tower 15F  
1-8-1, Shimo-Meguro, Meguro-ku,  
Tokyo 153-0064, Japan  
0120 191014  
+81 3 5437 9125  
support.japan@freescale.com

**Asia/Pacific:**  
Freescale Semiconductor Hong Kong Ltd.  
Technical Information Center  
2 Dai King Street  
Tai Po Industrial Estate,  
Tai Po, N.T., Hong Kong  
+800 2666 8080  
support.asia@freescale.com

**For Literature Requests Only:**  
Freescale Semiconductor  
Literature Distribution Center  
P.O. Box 5405  
Denver, Colorado 80217  
1-800-441-2447  
303-675-2140  
Fax: 303-675-2150  
LDCForFreescaleSemiconductor@hibbertgroup.com

Information in this document is provided solely to enable system and software implementers to use Freescale Semiconductor products. There are no express or implied copyright license granted hereunder to design or fabricate any integrated circuits or integrated circuits based on the information in this document.

Freescale Semiconductor reserves the right to make changes without further notice to any products herein. Freescale Semiconductor makes no warranty, representation or guarantee regarding the suitability of its products for any particular purpose, nor does Freescale Semiconductor assume any liability arising out of the application or use of any product or circuit, and specifically disclaims any and all liability, including without limitation consequential or incidental damages. "Typical" parameters which may be provided in Freescale Semiconductor data sheets and/or specifications can and do vary in different applications and actual performance may vary over time. All operating parameters, including "Typicals" must be validated for each customer application by customer's technical experts. Freescale Semiconductor does not convey any license under its patent rights nor the rights of others. Freescale Semiconductor products are not designed, intended, or authorized for use as components in systems intended for surgical implant into the body, or other applications intended to support or sustain life, or for any other application in which the failure of the Freescale Semiconductor product could create a situation where personal injury or death may occur. Should Buyer purchase or use Freescale Semiconductor products for any such unintended or unauthorized application, Buyer shall indemnify and hold Freescale Semiconductor and its officers, employees, subsidiaries, affiliates, and distributors harmless against all claims, costs, damages, and expenses, and reasonable attorney fees arising out of, directly or indirectly, any claim of personal injury or death associated with such unintended or unauthorized use, even if such claim alleges that Freescale Semiconductor was negligent regarding the design or manufacture of the part.

**Learn More:** For current information about Freescale products and documentation, please visit [freescale.com/QorIQ](http://freescale.com/QorIQ).



Freescale, the Freescale logo and QorIQ are trademarks of Freescale Semiconductor, Inc., Reg. U.S. Pat. & Tm. Off. All other product or service names are the property of their respective owners. The Power Architecture and Power.org word marks and the Power and Power.org logos and related marks are trademarks and service marks licensed by Power.org. © 2011 Freescale Semiconductor, Inc

Document Number: P1010APPBRF  
REV 0



# Mouser Electronics

Authorized Distributor

Click to View Pricing, Inventory, Delivery & Lifecycle Information:

## NXP:

[P1010NSE5DFA](#) [P1010NSE5FFA](#) [P1010NSE5HHA](#) [P1010NSN5DFA](#) [P1010NSN5FFA](#) [P1010NSN5HHA](#)  
[P1010NXE5DFA](#) [P1010NXE5FFA](#) [P1010NXE5HFA](#) [P1010NXN5DFA](#) [P1010NXN5FFA](#) [P1010NXN5HFA](#)  
[P1010NXN5HHA](#) [P1014NSE5DFA](#) [P1014NSE5FFA](#) [P1014NSE5HFA](#) [P1014NSE5HHA](#) [P1014NSN5DFA](#)  
[P1014NSN5HHA](#) [P1014NXE5DFA](#) [P1014NXE5FFA](#) [P1014NXE5HHA](#) [P1014NXN5DFA](#) [P1014NXN5FFA](#)  
[P1014NXN5HHA](#) [P1014NSN5FFA](#) [P1010NXE5HHA](#) [P1010NSE5HFA](#) [P1010NSN5HFA](#) [P1014NSN5HFA](#)  
[P1014NXE5HFA](#) [P1014NXN5HFA](#) [P1010NSE5KHA](#) [P1010NXE5KHA](#) [P1010NXN5KHA](#) [P1010NSN5KHA](#)