

## Product Specifications

Rating	Current rating : 0.3A	Operating Temperature Range : -35 to +85°C (Note 1.)	Storage Temperature Range : -10 to +60°C (Note 2.)
	Voltage rating : 50V AC	Operating Humidity Range : 40 to 80%	Storage Humidity Range : 40 to 70% (Note 2.)

Item	Specification	Condition
1. Insulation Resistance	500M ohms min.	100V DC
2. Withstanding Voltage	No flashover or insulation breakdown.	150V AC/1 minute
3. Contact Resistance	50m ohms max	100mA
4. Vibration	No electrical discontinuity of 1μs or more	Frequency: 10 to 55 Hz, single amplitude of 0.75 mm, 2 hours in each of the 3 directions.
5. Humidity (Steady state)	Contact resistance: 50m ohms max. Insulation resistance: 250M ohms min.	96 hours at temperature of 40°C and humidity of 90% to 95%
6. Temperature Cycle	Contact resistance : 50m ohms max. Insulation resistance: 500M ohms min.	(-55°C: 30 minutes 5 to 35°C: 10 minutes 85°C: 30 minutes 5 to 35°C: 10 minutes) 5 cycles
7. Durability (Mating/un-mating)	Contact resistance: 50m ohms max.	50 cycles
8. Resistance to Soldering heat	No deformation of components affecting performance.	Reflow: At the recommended temperature profile Manual soldering: 350°C for 3 seconds

Note 1: Includes temperature rise caused by current flow.

Note 2: The term "storage" refers to products stored for long period of time prior to mounting and use. Operating Temperature Range and Humidity range covers non conducting condition of installed connectors in storage, shipment or during transportation.

Note 3: Information contained in this catalog represents general requirements for this Series. Contact us for the drawings and specifications for a specific part number shown.

## Material

Product	Part	Material	Finish	Remarks
Receptacle	Insulator	Polyamide	Beige	UL94V-0
	Contact	Phosphor copper	Gold plated	————
	Metal fitting	Brass	Tin plated	————
Header	Insulator	Polyamide	Beige	UL94V-0
	Contact	Phosphor copper	Gold plated	————
	Metal fitting	Brass	Tin plated	————

Note: The gold plated product of pin herder consists of a contact area of gold plated and lead of tin plated

## Ordering Information

### ●Receptacle/Header

DF15   #   (\*\*)   -   \*   DS   -   0.65   V   (\*\*)

①   ②   ③   ④   ⑤   ⑥   ⑦   ⑧

① Series Name : DF15	④ Number of Contacts 20, 30, 40, 50															
② Type <table border="1" style="margin-left: 20px;"> <thead> <tr> <th></th> <th>Fitting</th> <th>Boss</th> </tr> </thead> <tbody> <tr> <td>Blank</td> <td style="text-align: center;">○</td> <td style="text-align: center;">○</td> </tr> <tr> <td>A</td> <td style="text-align: center;">×</td> <td style="text-align: center;">○</td> </tr> <tr> <td>B</td> <td style="text-align: center;">○</td> <td style="text-align: center;">×</td> </tr> <tr> <td>C</td> <td style="text-align: center;">×</td> <td style="text-align: center;">×</td> </tr> </tbody> </table>		Fitting	Boss	Blank	○	○	A	×	○	B	○	×	C	×	×	⑤ Connector Type DS : Double-row receptacle DP : Double-row header
	Fitting	Boss														
Blank	○	○														
A	×	○														
B	○	×														
C	×	×														
③ Product height Receptacle : 0.8, 1.8 Header : 3.2, 4.2, 6.2	⑥ Contact Pitch : 0.65mm ⑦ Contact type V : Straight SMT type ⑧ (56) : Embossed tape packaging															

■ Receptacle With metal fitting

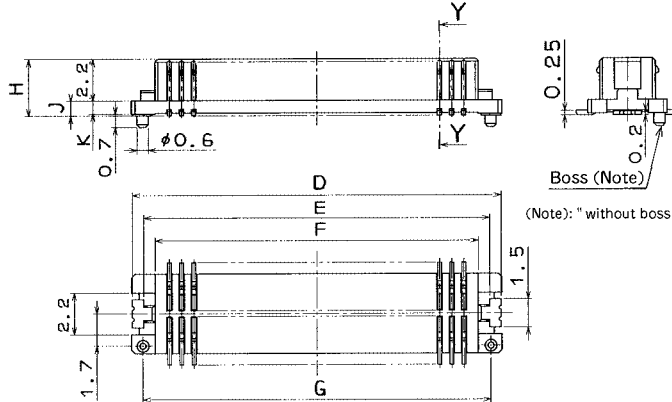
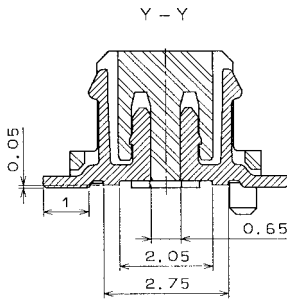
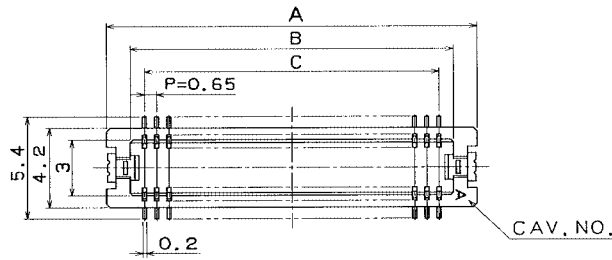
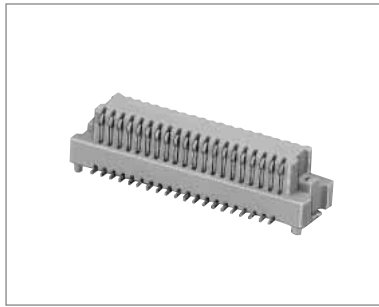

(Note): "without boss" indicates the form with no boss.

[Specific No.] -\* \*, (\* \*)  
(56) :Gold plated embossed tape packaging

● Product Height: 0.8mm Product

Unit: mm

Part Number	CL No.	Number of Contacts	A	B	C	D	E	F	G	H	J	K	Remarks	RoHS
DF15 (0.8)-20DS-0.65V(56)	677-0002-0-56	20	9.85	7.35	5.85	9.65	8.45	7.35	8.65	3	0.8	0.7	With metal fitting With boss	YES
DF15 (0.8)-30DS-0.65V(56)	677-0003-3-56	30	13.10	10.6	9.1	12.9	11.7	10.6	11.9					
DF15 (0.8)-40DS-0.65V(56)	677-0004-6-56	40	16.35	13.85	12.35	16.15	14.95	13.85	15.15					
DF15 (0.8)-50DS-0.65V(56)	677-0005-9-56	50	19.60	17.1	15.6	19.4	18.2	17.1	18.4	3	0.8	0.7	With metal fitting Without boss	YES
DF15B(0.8)-20DS-0.65V(56)	677-0022-8-56	20	9.85	7.35	5.85	9.65	8.45	7.35	-					
DF15B(0.8)-30DS-0.65V(56)	677-0023-0-56	30	13.10	10.6	9.1	12.9	11.7	10.6	-					
DF15B(0.8)-40DS-0.65V(56)	677-0024-3-56	40	16.35	13.85	12.35	16.15	14.95	13.85	-	4	1.8	1.7	With metal fitting With boss	YES
DF15B(0.8)-50DS-0.65V(56)	677-0025-6-56	50	19.60	17.1	15.6	19.4	18.2	17.1	-					

● Product Height: 1.8mm Product

Unit: mm

Part Number	CL No.	Number of Contacts	A	B	C	D	E	F	G	H	J	K	Remarks	RoHS
DF15 (1.8)-20DS-0.65V(56)	677-0042-5-56	20	9.85	7.35	5.85	9.65	8.45	7.35	8.65	4	1.8	1.7	With metal fitting With boss	YES
DF15 (1.8)-30DS-0.65V(56)	677-0043-8-56	30	13.1	10.6	9.1	12.9	11.7	10.6	11.9					
DF15 (1.8)-40DS-0.65V(56)	677-0044-0-56	40	16.35	13.85	12.35	16.15	14.95	13.85	15.15					
DF15 (1.8)-50DS-0.65V(56)	677-0045-3-56	50	19.6	17.1	15.6	19.4	18.2	17.1	18.4	4	1.8	1.7	With metal fitting Without boss	YES
DF15B(1.8)-20DS-0.65V(56)	677-0062-2-56	20	9.85	7.35	5.85	9.65	8.45	7.35	-					
DF15B(1.8)-30DS-0.65V(56)	677-0063-5-56	30	13.1	10.6	9.1	12.9	11.7	10.6	-					
DF15B(1.8)-40DS-0.65V(56)	677-0064-8-56	40	16.35	13.85	12.35	16.15	14.95	13.85	-	4	1.8	1.7	With metal fitting Without boss	YES
DF15B(1.8)-50DS-0.65V(56)	677-0065-0-56	50	19.6	17.1	15.6	19.4	18.2	17.1	-					

Note: Please order the embossed tape packaging product per reel. (1000 pcs./reel)

Header Without metal fitting

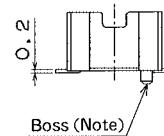
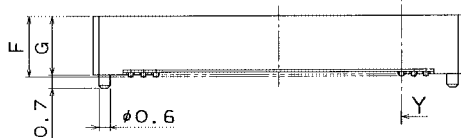
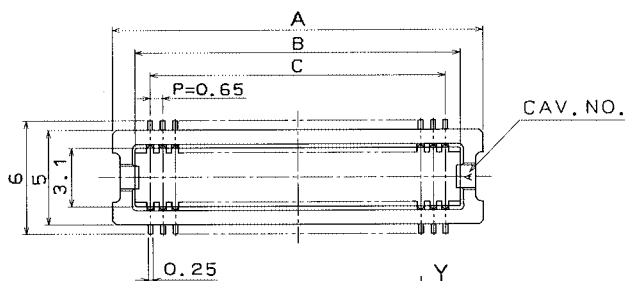

(Note): "without boss" indicates the form with no boss.

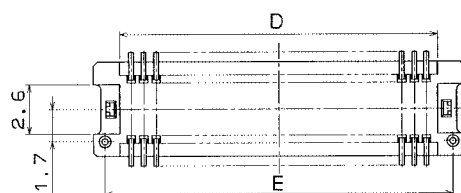
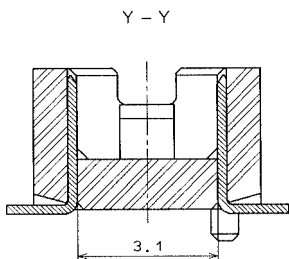

[Specific No.] -\*\* , (\*\*)  
 (56) :Gold plated embossed tape packaging

Product Height: 3.2mm Product

Unit: mm

Part Number	CL No.	Number of Contacts	A	B	C	D	E	F	G	Remarks	RoHS
DF15A(3.2)-20DP-0.65V(56)	677-0092-3-56	20	9.85	7.45	5.85	7.05	8.65	3.2	3.1	Without metal fitting With boss	YES
DF15A(3.2)-30DP-0.65V(56)	677-0093-6-56	30	13.1	10.7	9.1	10.3	11.9				
DF15A(3.2)-40DP-0.65V(56)	677-0094-9-56	40	16.35	13.95	12.35	13.55	15.15				
DF15C(3.2)-20DP-0.65V(56)	677-0112-9-56	20	9.85	7.45	5.85	7.05	-	3.2	3.1	Without metal fitting Without boss	YES
DF15C(3.2)-30DP-0.65V(56)	677-0113-1-56	30	13.1	10.7	9.1	10.3	-				
DF15C(3.2)-40DP-0.65V(56)	677-0114-4-56	40	16.35	13.95	12.35	13.55	-				
DF15C(3.2)-50DP-0.65V(56)	677-0115-7-56	50	19.6	17.2	15.6	16.8	-				

Note: Please order the embossed tape packaging product per reel. (1000 pcs./reel)

Oct.1.2021 Copyright 2021 HIROSE ELECTRIC CO., LTD. All Rights Reserved.

■Header Without metal fitting

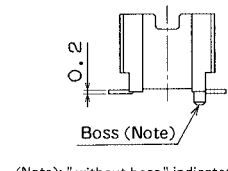
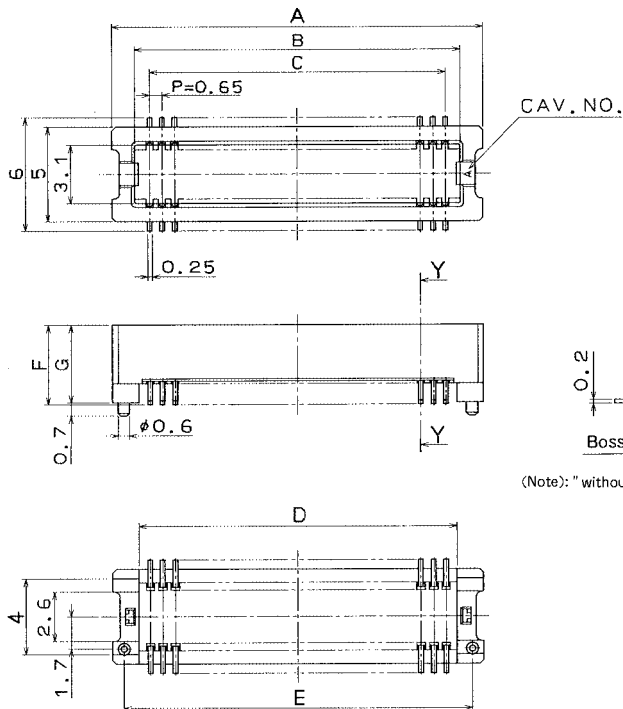
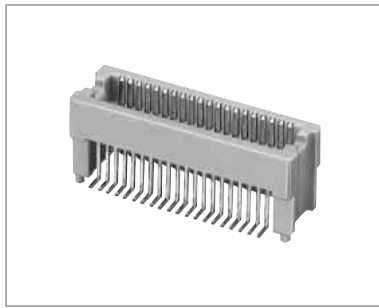

(Note): "without boss" indicates the form with no boss.

[Specific No.] -\* \*, (\* \*)  
(56) :Gold plated embossed tape packaging

●Product Height: 4.2mm Product

Unit: mm

Part Number	CL No.	Number of Contacts	A	B	C	D	E	F	G	Remarks	RoHS
DF15A(4.2)-20DP-0.65V(56)	677-0132-6-56	20	9.85	7.45	5.85	7.05	8.65	4.2	4.1	Without metal fitting With boss	YES
DF15A(4.2)-30DP-0.65V(56)	677-0133-9-56	30	13.1	10.7	9.1	10.3	11.9				
DF15A(4.2)-40DP-0.65V(56)	677-0134-1-56	40	16.35	13.95	12.35	13.55	15.15				
DF15A(4.2)-50DP-0.65V(56)	677-0135-4-56	50	19.6	17.2	15.6	16.8	18.4				
DF15C(4.2)-20DP-0.65V(56)	677-0152-3-56	20	9.85	7.45	5.85	7.05	-	4.2	4.1	Without metal fitting Without boss	YES
DF15C(4.2)-30DP-0.65V(56)	677-0153-6-56	30	13.1	10.7	9.1	10.3	-				
DF15C(4.2)-40DP-0.65V(56)	677-0154-9-56	40	16.35	13.95	12.35	13.55	-				
DF15C(4.2)-50DP-0.65V(56)	677-0155-1-56	50	19.6	17.2	15.6	16.8	-				

●Product Height: 6.2mm Product

Unit: mm

Part Number	CL No.	Number of Contacts	A	B	C	D	E	F	G	Remarks	RoHS
DF15A(6.2)-20DP-0.65V(56)	677-0172-0-56	20	9.85	7.45	5.85	7.05	8.65	6.2	6.1	Without metal fitting With boss	YES
DF15A(6.2)-30DP-0.65V(56)	677-0173-3-56	30	13.1	10.7	9.1	10.3	11.9				
DF15A(6.2)-40DP-0.65V(56)	677-0174-6-56	40	16.35	13.95	12.35	13.55	15.15				
DF15A(6.2)-50DP-0.65V(56)	677-0175-9-56	50	19.6	17.2	15.6	16.8	18.4				
DF15C(6.2)-20DP-0.65V(56)	677-0192-8-56	20	9.85	7.45	5.85	7.05	-	6.2	6.1	Without metal fitting Without boss	YES
DF15C(6.2)-30DP-0.65V(56)	677-0193-0-56	30	13.1	10.7	9.1	10.3	-				
DF15C(6.2)-40DP-0.65V(56)	677-0194-3-56	40	16.35	13.95	12.35	13.55	-				
DF15C(6.2)-50DP-0.65V(56)	677-0195-6-56	50	19.6	17.2	15.6	16.8	-				

Note: Please order the embossed tape packaging product per reel. (1000 pcs./reel)

**Header** With metal fitting

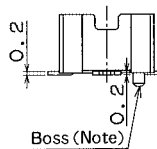
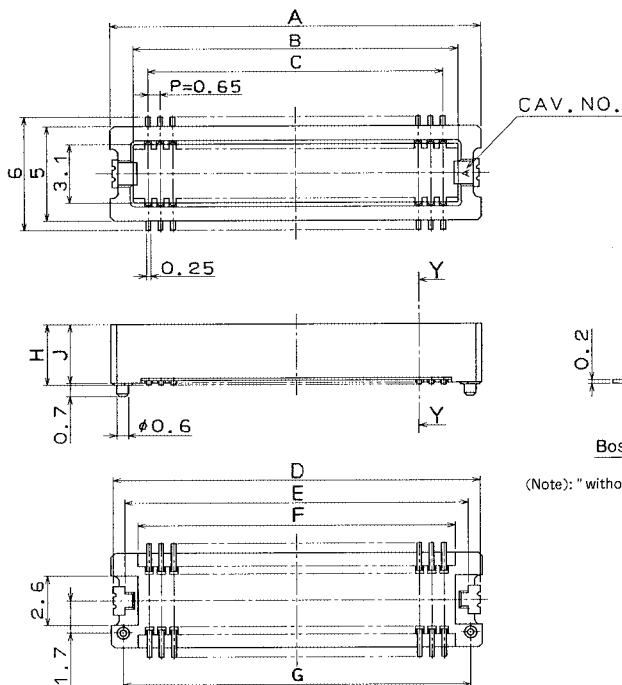
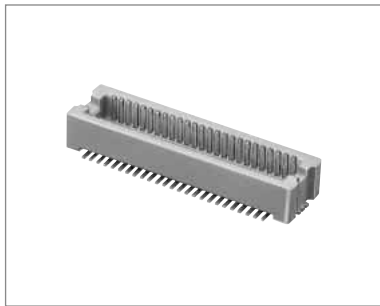

(Note): "without boss" indicates the form with no boss.

[Specific No.] -\* \*, (\* \*)  
(56) :Gold plated embossed tape packaging

**Product Height: 3.2mm Product**

Unit: mm

Part Number	CL No.	Number of Contacts	A	B	C	D	E	F	G	H	J	Remarks	RoHS
DF15 (3.2)-20DP-0.65V(56)	677-0082-0-56	20	9.85	7.45	5.85	9.65	8.45	7.05	8.65	3.2	3.1	With metal fitting With boss	YES
DF15 (3.2)-30DP-0.65V(56)	677-0083-2-56	30	13.1	10.7	9.1	12.9	11.7	10.3	11.9				
DF15 (3.2)-40DP-0.65V(56)	677-0084-5-56	40	16.35	13.95	12.35	16.15	14.95	13.55	15.15				
DF15 (3.2)-50DP-0.65V(56)	677-0085-8-56	50	19.6	17.2	15.6	19.4	18.2	16.8	18.4	3.2	3.1	With metal fitting Without boss	YES
DF15B(3.2)-20DP-0.65V(56)	677-0102-5-56	20	9.85	7.45	5.85	9.65	8.45	7.05	-				
DF15B(3.2)-30DP-0.65V(56)	677-0103-8-56	30	13.1	10.7	9.1	12.9	11.7	10.3	-				
DF15B(3.2)-40DP-0.65V(56)	677-0104-0-56	40	16.35	13.95	12.35	16.15	14.95	13.55	-				
DF15B(3.2)-50DP-0.65V(56)	677-0105-3-56	50	19.6	17.2	15.6	19.4	18.2	16.8	-				

Note: Please order the embossed tape packaging product per reel. (1000 pcs./reel)

Oct.1.2021 Copyright 2021 HIROSE ELECTRIC CO., LTD. All Rights Reserved.

Header With metal fitting

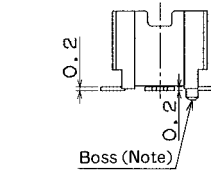
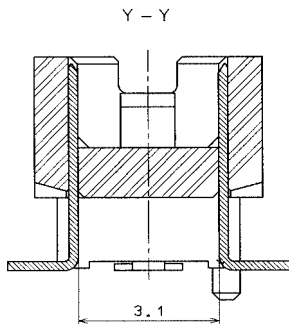
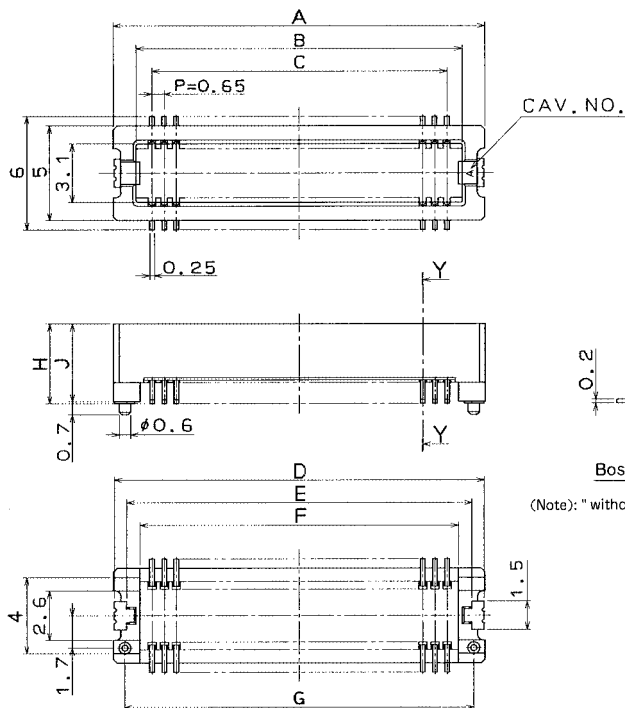
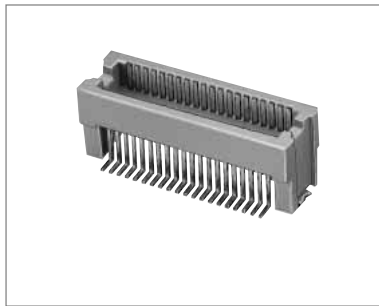

(Note): "without boss" indicates the form with no boss.

[Specific No.] -\* \*, (\* \*)  
(56) :Gold plated embossed tape packaging

●Product Height: 4.2mm Product

Unit: mm

Part Number	CL No.	Number of Contacts	A	B	C	D	E	F	G	H	J	Remarks	RoHS
DF15 (4.2)-20DP-0.65V(56)	677-0122-2-56	20	9.85	7.45	5.85	9.65	8.45	7.05	8.65	4.2	4.1	With metal fitting With boss	YES
DF15 (4.2)-30DP-0.65V(56)	677-0123-5-56	30	13.1	10.7	9.1	12.9	11.7	10.3	11.9				
DF15 (4.2)-40DP-0.65V(56)	677-0124-8-56	40	16.35	13.95	12.35	16.15	14.95	13.55	15.15				
DF15 (4.2)-50DP-0.65V(56)	677-0125-0-56	50	19.6	17.2	15.6	19.4	18.2	16.8	18.4				
DF15B(4.2)-20DP-0.65V(56)	677-0142-0-56	20	9.85	7.45	5.85	9.65	8.45	7.05	-	4.2	4.1	With metal fitting Without boss	YES
DF15B(4.2)-30DP-0.65V(56)	677-0143-2-56	30	13.1	10.7	9.1	12.9	11.7	10.3	-				
DF15B(4.2)-40DP-0.65V(56)	677-0144-5-56	40	16.35	13.95	12.35	16.15	14.95	13.55	-				
DF15B(4.2)-50DP-0.65V(56)	677-0145-8-56	50	19.6	17.2	15.6	19.4	18.2	16.8	-				

●Product Height: 6.2mm Product

Unit: mm

Part Number	CL No.	Number of Contacts	A	B	C	D	E	F	G	H	J	Remarks	RoHS
DF15 (6.2)-20DP-0.65V(56)	677-0162-7-56	20	9.85	7.45	5.85	9.65	8.45	7.05	8.65	6.2	6.1	With metal fitting With boss	YES
DF15 (6.2)-30DP-0.65V(56)	677-0163-0-56	30	13.1	10.7	9.1	12.9	11.7	10.3	11.9				
DF15 (6.2)-40DP-0.65V(56)	677-0164-2-56	40	16.35	13.95	12.35	16.15	14.95	13.55	15.15				
DF15 (6.2)-50DP-0.65V(56)	677-0165-5-56	50	19.6	17.2	15.6	19.4	18.2	16.8	18.4				
DF15B(6.2)-20DP-0.65V(56)	677-0182-4-56	20	9.85	7.45	5.85	9.65	8.45	7.05	-	6.2	6.1	With metal fitting Without boss	YES
DF15B(6.2)-30DP-0.65V(56)	677-0183-7-56	30	13.1	10.7	9.1	12.9	11.7	10.3	-				
DF15B(6.2)-40DP-0.65V(56)	677-0184-0-56	40	16.35	13.95	12.35	16.15	14.95	13.55	-				
DF15B(6.2)-50DP-0.65V(56)	677-0185-2-56	50	19.6	17.2	15.6	19.4	18.2	16.8	-				

Note: Please order the embossed tape packaging product per reel. (1000 pcs./reel)

Oct.1.2021 Copyright 2021 HIROSE ELECTRIC CO., LTD. All Rights Reserved.

### ◆ Recommended PCB mounting pattern

(Unit: mm)

#### ● Receptacle

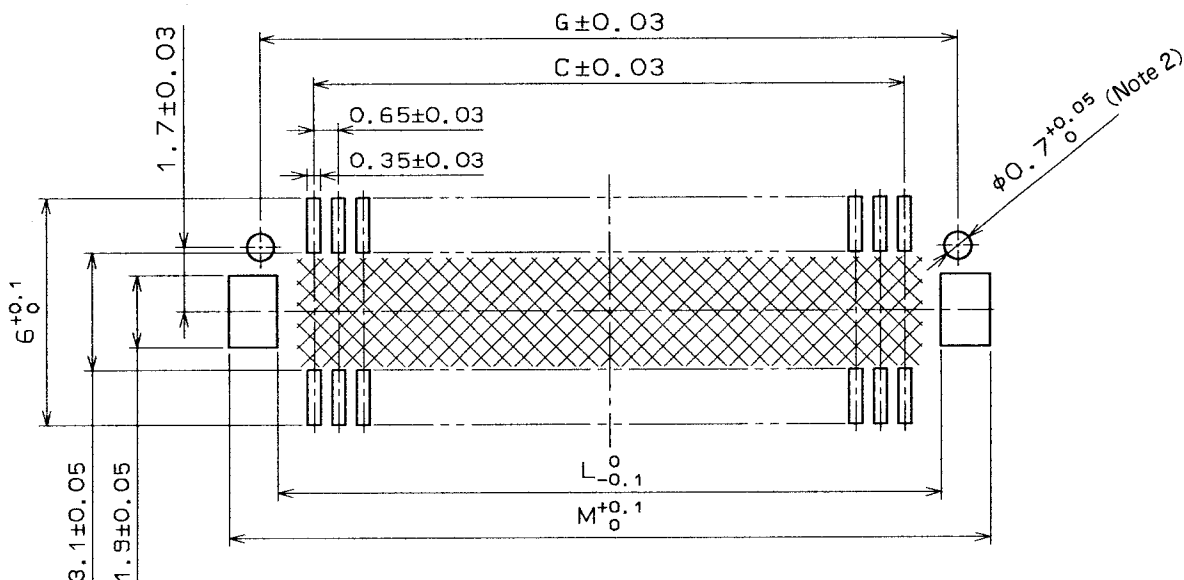

Note1: If the pattern is included in the shaded area, and not treated with resist, it could touch the connector contact.

#### ● Header

(Unit: mm)

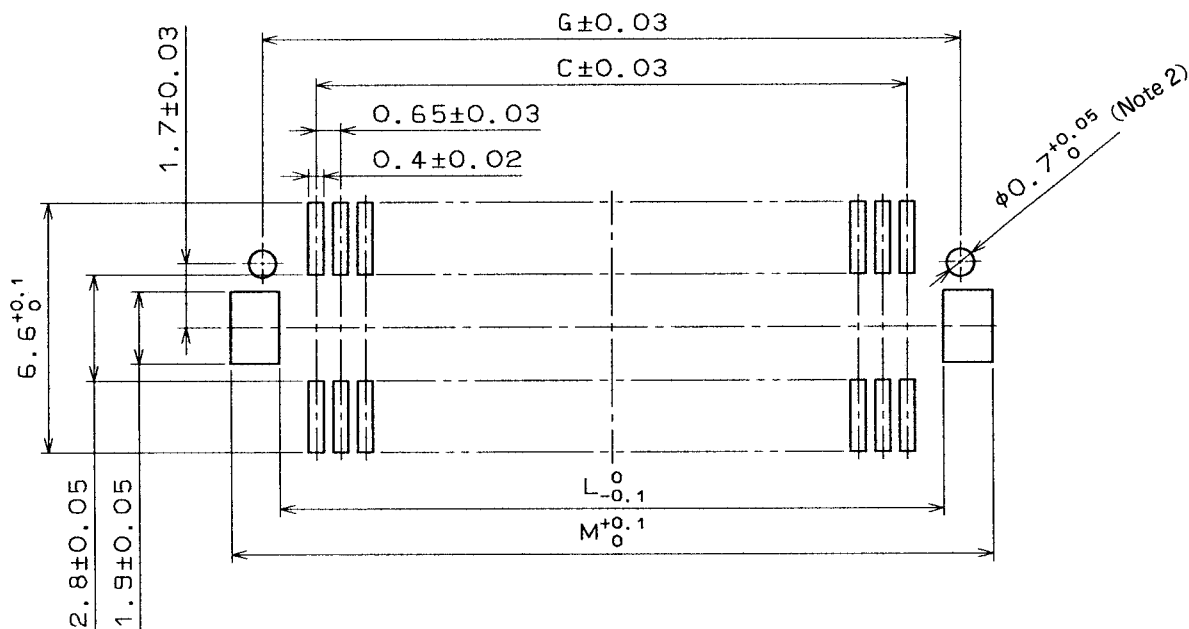

Unit: mm

Number of Contacts	C	G	L	M
20	5.85	8.65	7.85	10.25
30	9.1	11.9	11.1	13.5
40	12.35	15.15	14.35	16.75
50	15.6	18.4	17.6	20

# Embossed Carrier Tape Dimensions

## Receptacle

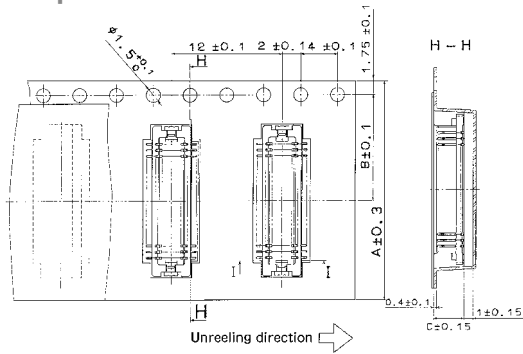

(20, 30, 40 contacts)

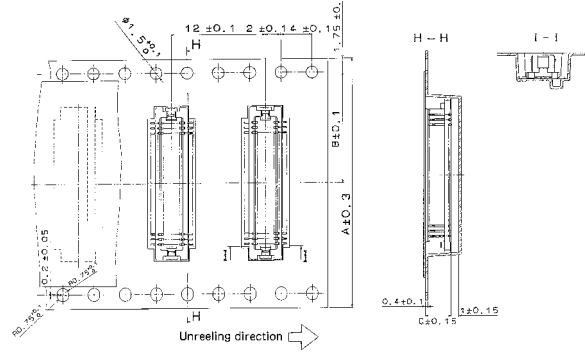

(50 contacts)

## Header

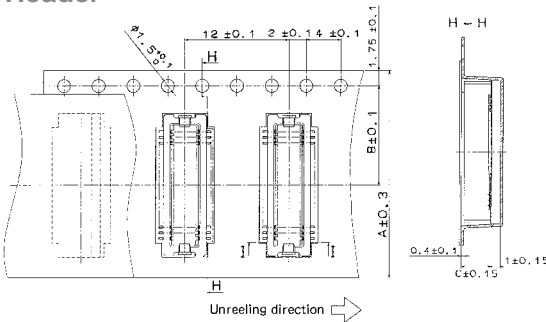

(20, 30, 40 contacts)

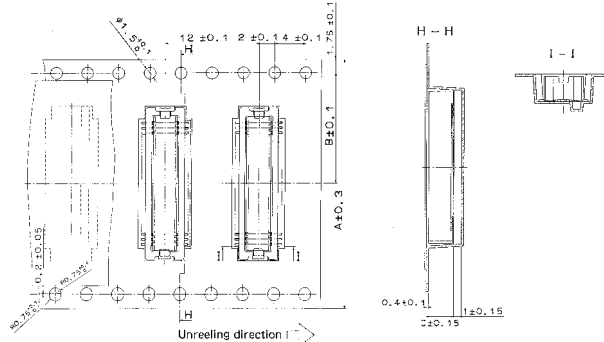

(50 contacts)

## Reel Dimensions

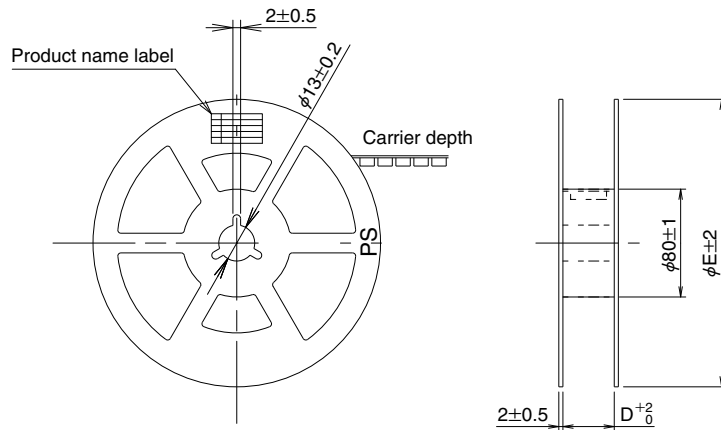

Unit:mm

Connector	A	B	C	D	E	Connector	A	B	C	D	E
DF15#(0.8)-20DS-0.65V	16	7.5	3.3	17.5	330	DF15#(3.2)-20DP-0.65V	16	7.5	3.5	17.5	330
DF15#(0.8)-30DS-0.65V	24	11.5	3.3	25.5		DF15#(3.2)-30DP-0.65V	24	11.5	3.5	25.5	
DF15#(0.8)-40DS-0.65V	24	11.5	3.3	25.5		DF15#(3.2)-40DP-0.65V	24	11.5	3.5	25.5	
DF15#(0.8)-50DS-0.65V	32	14.2	3.3	33.5		DF15#(3.2)-50DP-0.65V	32	14.5	3.5	33.5	
DF15#(1.8)-20DS-0.65V	16	7.5	4.3	17.5		DF15#(4.2)-20DP-0.65V	16	7.5	4.5	17.5	
DF15#(1.8)-30DS-0.65V	24	11.5	4.3	25.5		DF15#(4.2)-30DP-0.65V	24	11.5	4.5	25.5	
DF15#(1.8)-40DS-0.65V	24	11.5	4.3	25.5		DF15#(4.2)-40DP-0.65V	24	11.5	4.5	25.5	
DF15#(1.8)-50DS-0.65V	32	14.2	4.3	33.5		DF15#(4.2)-50DP-0.65V	32	14.5	4.5	33.5	
						DF15#(6.2)-20DP-0.65V	16	7.5	6.5	17.5	380
						DF15#(6.2)-30DP-0.65V	24	11.5	6.5	25.5	
						DF15#(6.2)-40DP-0.65V	24	11.5	6.5	25.5	
						DF15#(6.2)-50DP-0.65V	32	14.5	6.5	33.5	

Oct.1.2021 Copyright 2021 HIROSE ELECTRIC CO., LTD. All Rights Reserved.

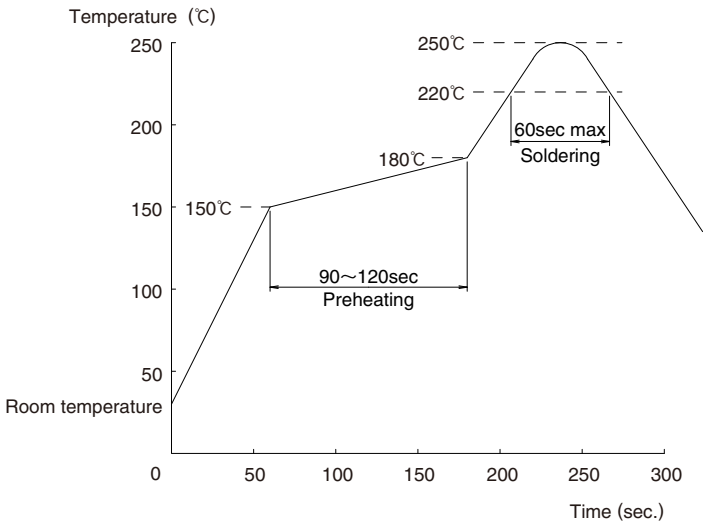

## ◆ Precautions

1. Recommended Temperature Profile (SMT)	 <p>Note1: Up to 2 cycles of Reflow soldering are possible under the same conditions, provided that there is a return to normal temperature between the first and second cycle.</p> <p>Note2: The temperature profile indicates the board surface temperature at the point of contacts with the connector terminals.</p>
2. Recommended Manual Soldering Condition (SMT)	Soldering iron temperature: $350\pm 10^{\circ}\text{C}$ , Soldering time: Within 3 seconds
3. Recommended Screen Thickness (SMT)	0.15mm
4. Board Warp (SMT)	Max 0.02mm in the connector center area, based on the both connector edges
5. Cleaning Condition	Refer to the "Nylon Connector Use Hand book".
6. Cautions	<ul style="list-style-type: none"> <li>■ The receptacle is designed in a structure where contacts are exposed. Touching it with bare hands would cause contact failure or electrostatic element damage.</li> <li>■ Where no board is mounted, the insertion or extraction will cause damage or deformation in the contacts.</li> <li>■ Avoid retaining the board with the connector only, and fix the board by any other means than the connector.</li> <li>■ Excessive scoop insertion or extraction may result in damage.</li> <li>■ In the manual soldering process, don't carry out the flux coating which will cause a flux blister on the connector.</li> <li>■ The color phase of this product may be slightly different from that of the formed product according to the manufacturing lot. However, the difference doesn't affect the performance.</li> </ul>

# Mouser Electronics

Authorized Distributor

Click to View Pricing, Inventory, Delivery & Lifecycle Information:

## [Hirose Electric:](#)

[DF15\(0.8\)-30DS-0.65V\(56\)](#) [DF15\(0.8\)-50DS-0.65V\(56\)](#) [DF15\(3.2\)-20DP-0.65V\(56\)](#) [DF15\(3.2\)-30DP-0.65V\(56\)](#)  
[DF15B\(3.2\)-20DP-0.65V\(56\)](#) [DF15\(4.2\)-20DP-0.65V\(56\)](#) [DF15\(6.2\)-30DP-0.65V\(56\)](#)