

Photologic® Slotted Optical Switch OPB460, OPB470, OPB480, OPB490 Series

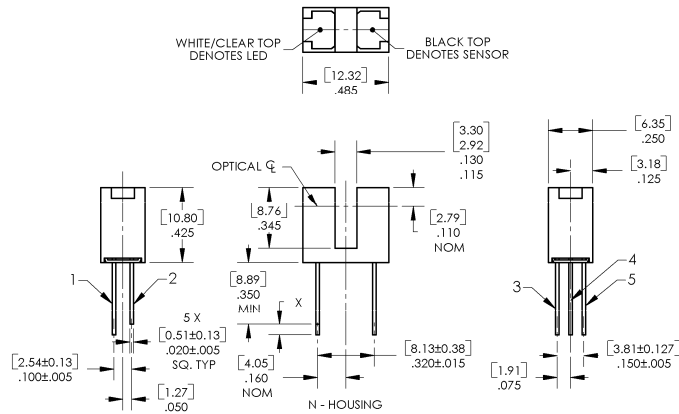

Color—Pin #	Description
Red—1	Anode
Black—2	Cathode
Green—3	Ground
Blue—4	Output
White—5	Vcc

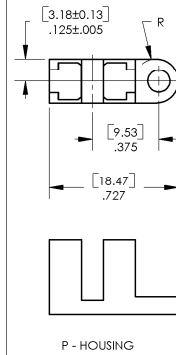
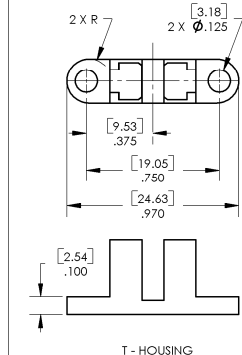
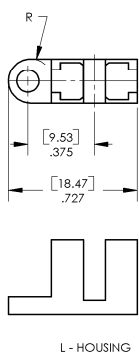

DIMENSIONS ARE IN: [MILLIMETERS]
INCHES

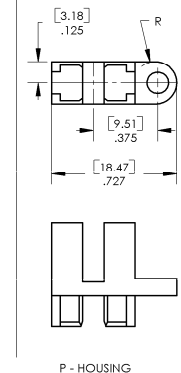
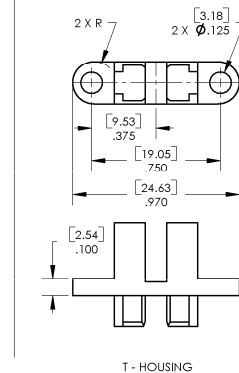
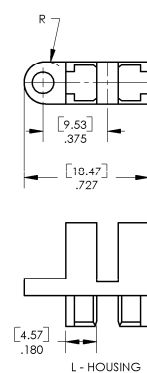
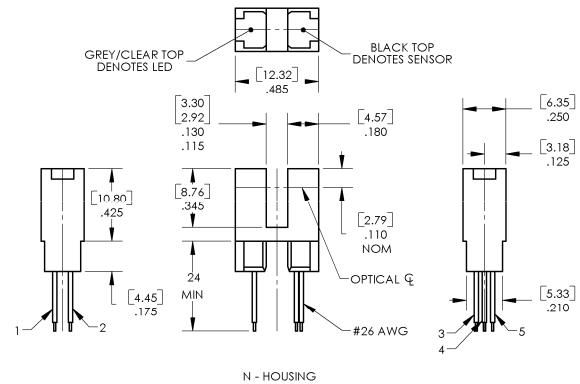

CONTAINS POLYSULFONE
To avoid stress cracking, we suggest using ND Industries' **Vibra-Tite** for thread-locking. **Vibra-Tite** evaporates fast without causing structural failure in OPTEK's molded plastics.
Applies to: OPB460, OPB470, OPB480, OPB490.

OPTEK reserves the right to make changes at any time in order to improve design and to supply the best product possible.

Absolute Maximum Ratings ($T_A=25^{\circ}\text{C}$ unless otherwise noted)

Storage & Operating Temperature Range	-40° C to +85° C
Lead Soldering Temperature [1/16 inch (1.6mm) from the case for 5 sec. with soldering iron] ⁽¹⁾	260°C

Input Infrared LED

Supply Voltage, V_{CC} (not to exceed 3 seconds)	18 V
Diode Forward DC Current	40 mA
Diode Reverse DC Voltage	2 V
Input Diode Power Dissipation ⁽²⁾	75 mW

Output Photologic®

Voltage at Output Lead (Open Collector Output)	25 V
Output Photologic® Power Dissipation ⁽³⁾	200 mW

Total Device Power Dissipation ⁽⁴⁾	275 mW
---	--------

Notes:

- (1) RMA flux is recommended. Duration can be extended to 10 seconds maximum when flow soldering.
- (2) Derate linearly 1.67 mW/°C above 25° C (OPB460, OPB470) or derate linearly 1.82 mW/°C above 25° C (OPB480, OPB490).
- (3) Derate linearly 1.50 mW/°C above 25° C (OPB460, OPB470) or derate linearly 1.64 mW/°C above 25° C (OPB480, OPB490).
- (4) Derate linearly 3.17 mW/°C above 25° C (OPB460, OPB470) or derate linearly 3.45 mW/°C above 25° C (OPB480, OPB490).
- (5) The OPB460/OPB470 series are terminated with 0.020" square leads designed for printed circuit board mounting.
- (6) The OPB480/OPB490 series of switches are terminated with 24" (609.600 mm) of 7-strand 26 AWG, UL rated insulated wire on each terminal. Insulation colors and functions are: red (anode), black (cathode), white (V_{CC}), blue (output) and green (ground). Other wire lengths and/or colors in addition to customer selected connectors are available. Contact your local representative or call the factory.

OPB460/470/480/490 Buffered 10K Pull-Up

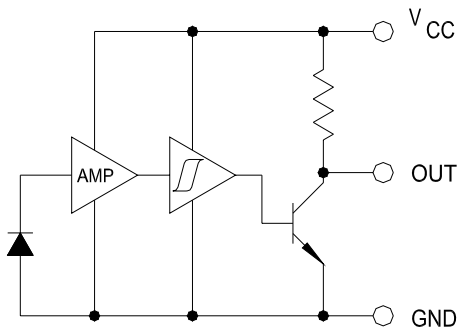

OPB461/471/481/491 Buffered Open-Collector

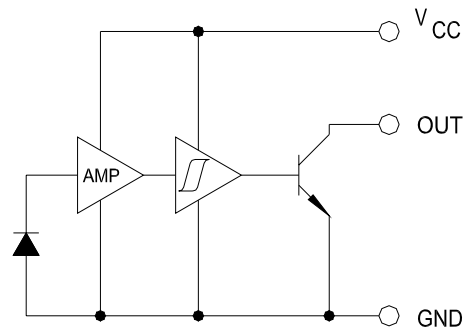

OPB462/472/482/492 Inverted 10K Pull-Up

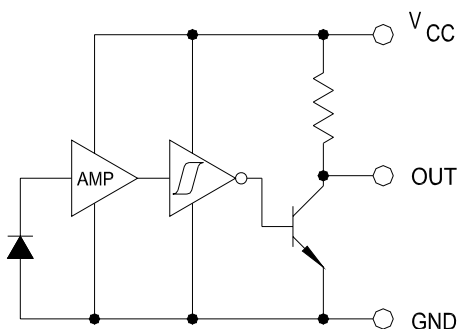

OPB463/473/483/493 Inverted Open-Collector

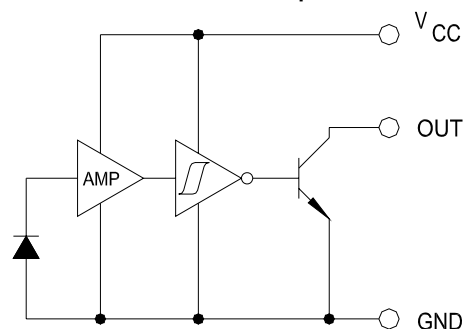

OPTEK reserves the right to make changes at any time in order to improve design and to supply the best product possible.

Electrical Characteristics ($T_A = 25^\circ\text{C}$ unless otherwise noted)

SYMBOL	PARAMETER	MIN	TYP	MAX	UNITS	TEST CONDITIONS
--------	-----------	-----	-----	-----	-------	-----------------

Input Diode

V_F	Forward Voltage	-	-	1.7	V	$I_F = 20\text{ mA}$, $T_A = 25^\circ\text{C}$
I_R	Reverse Current	-	-	100	μA	$V_R = 2\text{ V}$, $T_A = 25^\circ\text{C}$

Output Photologic® Sensor

V_{CC}	Operating DC Supply Voltage	4.5	-	16	V	
I_{CCL}	Low Level Supply Current: Buffered with 10k pull-up ⁽¹⁾ Buffered Open-Collector Output	-	-	7.5	mA	$V_{CC} = 16\text{ V}$, $I_F = 0\text{ mA}$ ⁽¹⁾
	Inverted with 10k pull-up: Inverted Open-Collector Output	-	-	7.5	mA	$V_{CC} = 16\text{ V}$, $I_F = 12\text{ mA}$
I_{CCH}	High Level Supply Current: Buffered with 10k pull-up Buffered Open-Collector Output	-	-	7.5	mA	$V_{CC} = 16\text{ V}$, $I_F = 12\text{ mA}$
	Inverted with 10k pull-up: Inverted Open-Collector Output	-	-	7.5	mA	$V_{CC} = 16\text{ V}$, $I_F = 0\text{ mA}$ ⁽¹⁾
V_{OL}	Low Level Output Voltage: Buffered with 10k pull-up Buffered Open-Collector Output	-	-	0.4	V	$V_{CC} = 4.5\text{ V}$, $I_{OL} = 16\text{ mA}$, $I_F = 0\text{ mA}$
	Inverted with 10k pull-up: Inverted Open-Collector Output	-	-	0.4	V	$V_{CC} = 4.5\text{ V}$, $I_F = 12\text{ mA}$ ⁽¹⁾
V_{OH}	High Level Output Voltage: Buffered with 10k pull-up	V_{CC} -1.5	-	-	V	$V_{CC} = 4.5\text{ V to }16\text{ V}$, No Load, $I_F = 12\text{ mA}$
	Inverted with 10k pull-up: Inverted Open-Collector Output ⁽¹⁾	V_{CC} -1.5	-	-	V	$V_{CC} = 4.5\text{ V to }16\text{ V}$, No Load, $I_F = 0\text{ mA}$
I_{OH}	High Level Output Current: Buffered Open-Collector Output	-	-	14	μA	$V_{CC} = 16\text{ V}$, $I_F = 12\text{ mA}$, $V_{OH} = 25\text{ V}$, $T_A = 25^\circ\text{C}$
	Inverted with 10k pull-up: Inverted Open-Collector Output ⁽¹⁾	-	-	14	μA	$V_{CC} = 16\text{ V}$, $I_F = 0\text{ mA}$, $V_{OH} = 25\text{ V}$, $T_A = 25^\circ\text{C}$
$I_{F(+)}$	LED Positive-Going Threshold Current	-	-	10	mA	$V_{CC} = 5\text{ V}$, $T_A = 25^\circ\text{C}$
$I_{F(+)} I_{F(-)}$	Hysteresis	-	1.4	-	-	$V_{CC} = 5\text{ V}$
t_r, t_f	Rise Time, Fall Time	-	50	-	ns	$V_{CC} = 5\text{ V}$, $T_A = 25^\circ\text{C}$, $I_F = 0$ or 12 mA
t_{PLH}, t_{PHL}	Propagation Delay	-	3	-	μs	$R_L = 300\ \Omega$ to 5 V , $C_L = 50\text{ pF}$

Notes:

- (1) Normal application would be with light source blocked, simulated by $I_F = 0\text{ mA}$.
- (2) All parameters tested using pulse technique.

OPTEK reserves the right to make changes at any time in order to improve design and to supply the best product possible.

OPB480T55 - Flag Next to Emitter

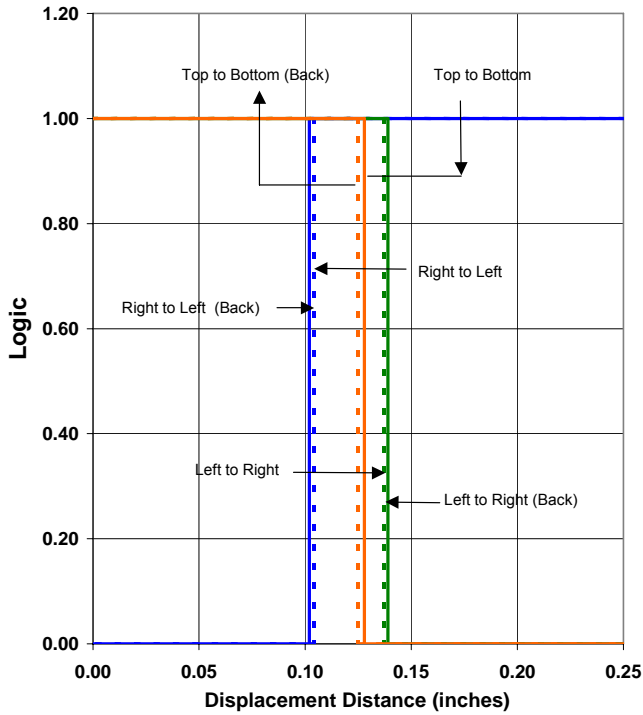

OPB480T55 - Flag Next to Sensor

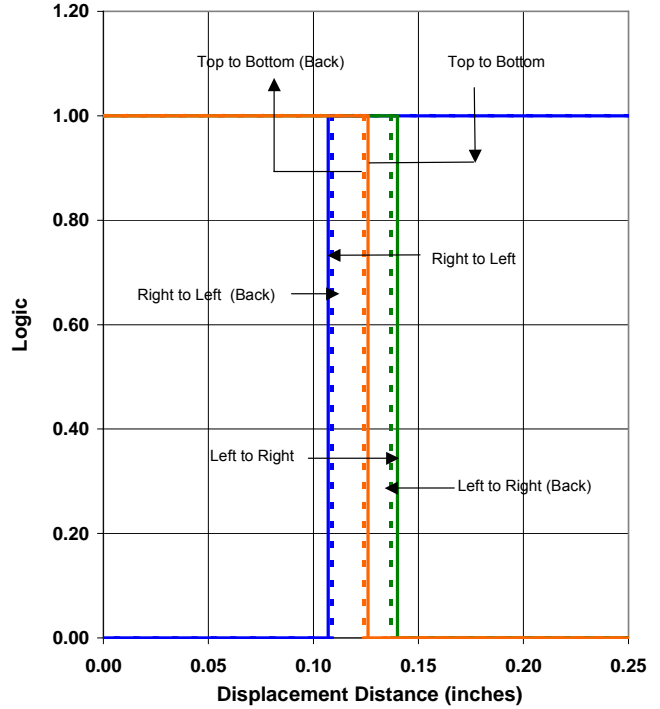

OPB480T55 - Flag in Middle of Slot

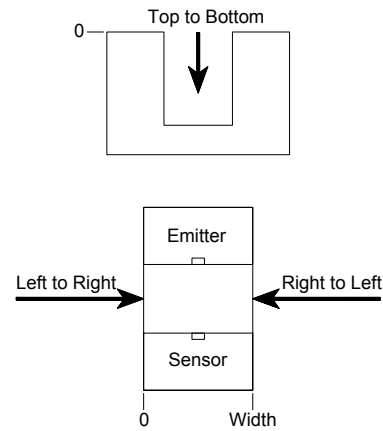
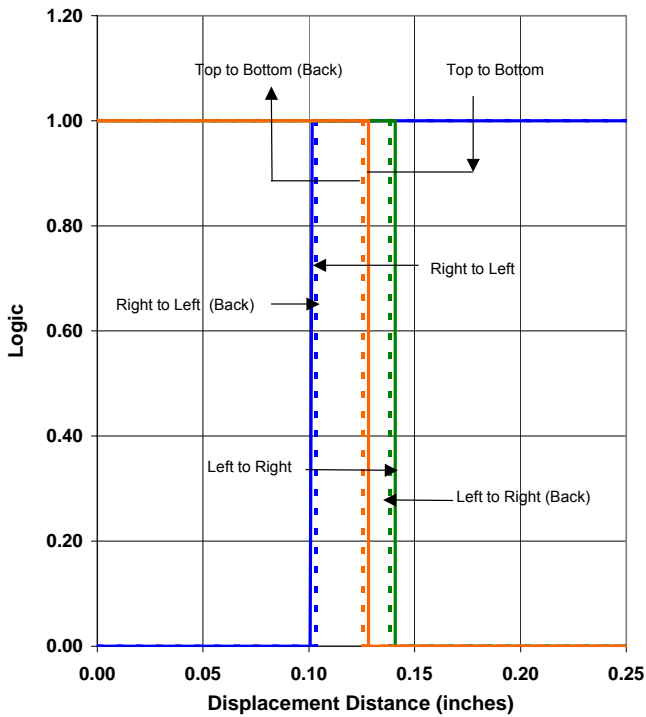

OPTEK reserves the right to make changes at any time in order to improve design and to supply the best product possible.

OPB481N51 - Flag Next to Emitter

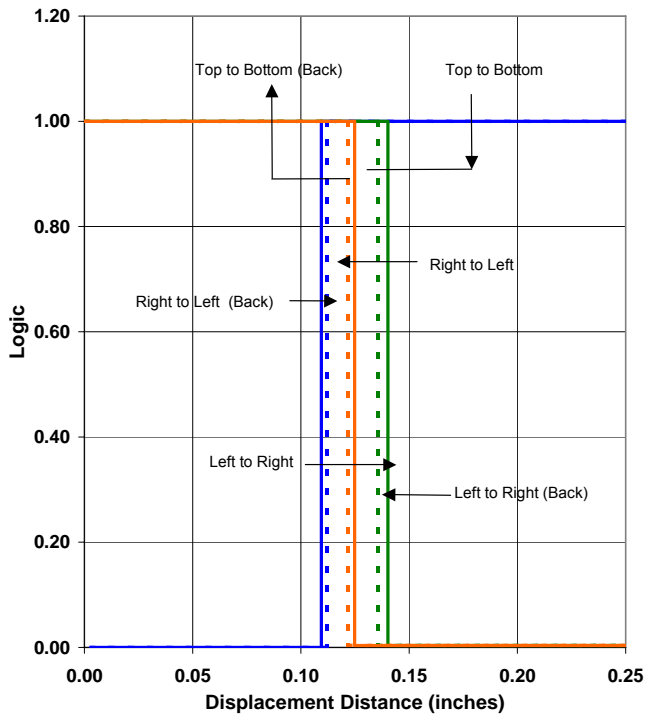

OPB481N51 - Flag Next to Sensor

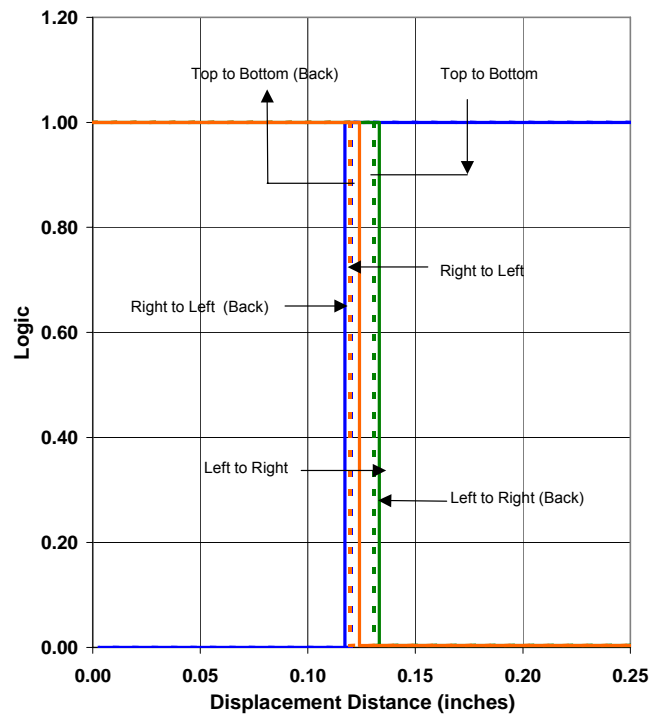

OPB481N51 - Flag in Middle of Slot

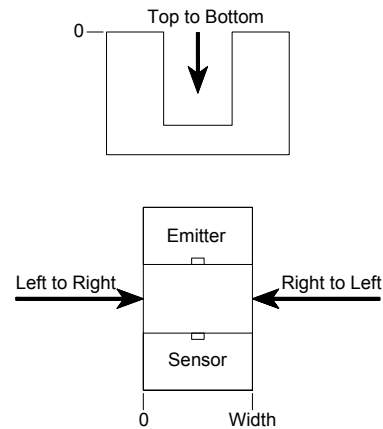
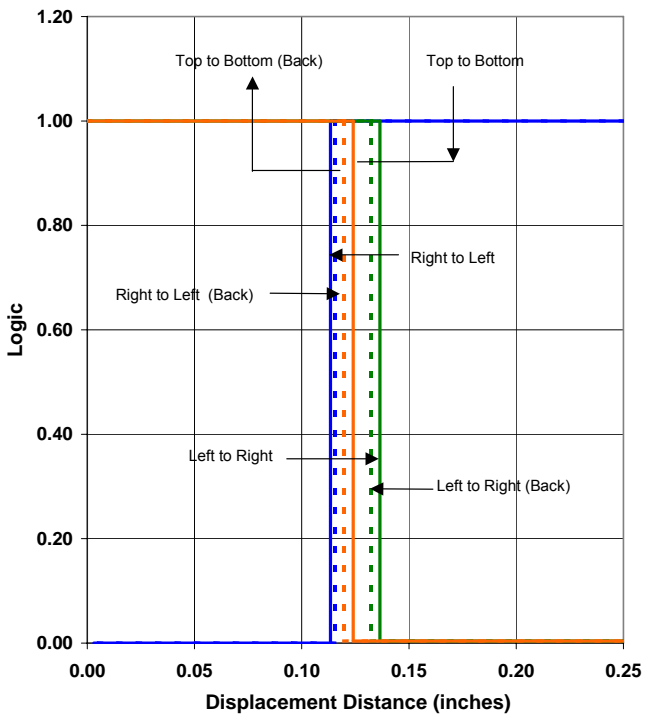

OPTEK reserves the right to make changes at any time in order to improve design and to supply the best product possible.

OPB460N11 - Flag Next to Emitter

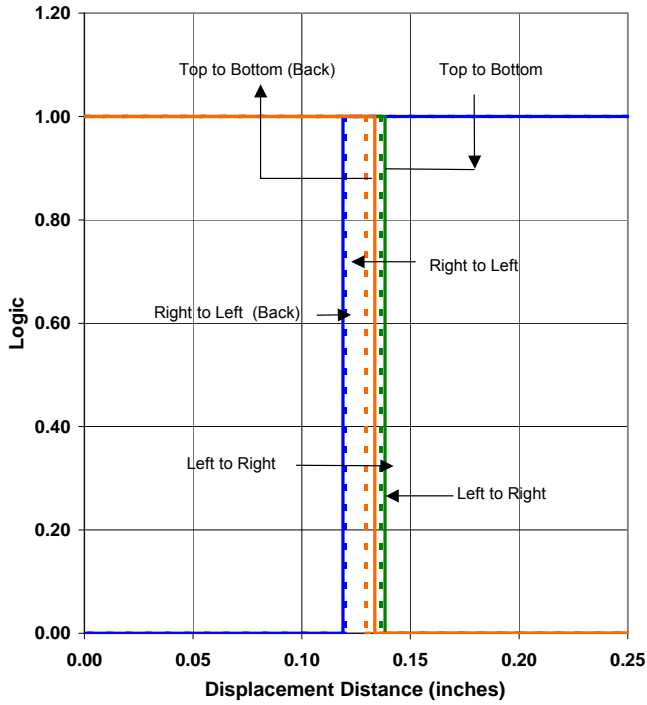

OPB460N11 - Flag Next to Sensor

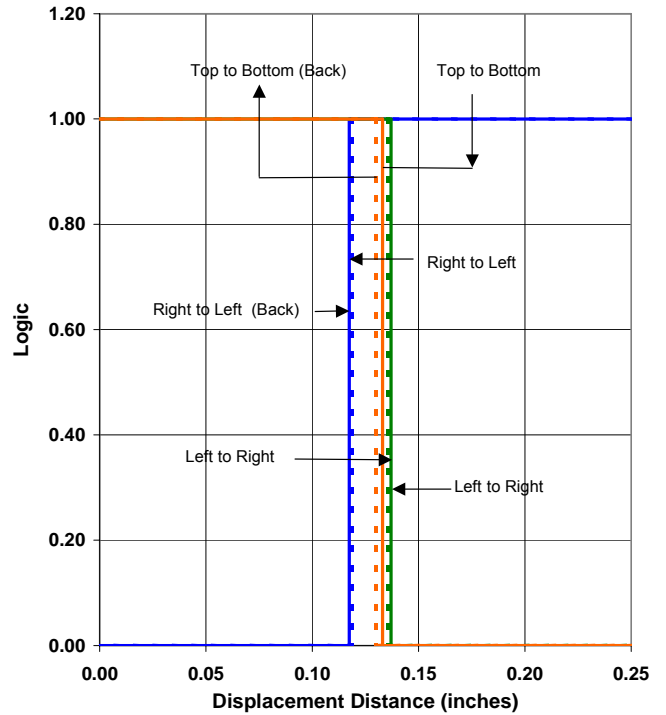

OPB460N11 - Flag in Middle of Slot

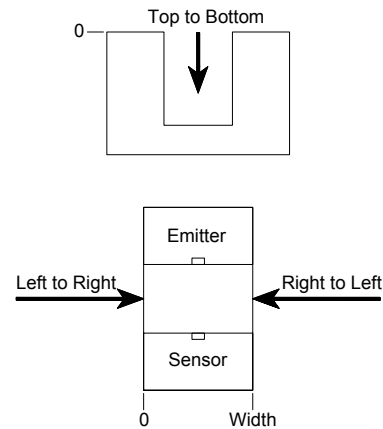
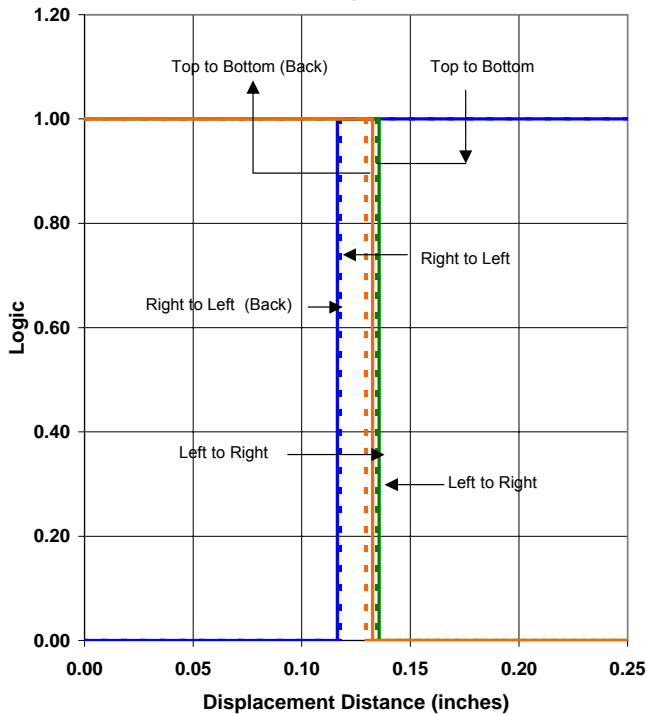

OPTEK reserves the right to make changes at any time in order to improve design and to supply the best product possible.

Mouser Electronics

Authorized Distributor

Click to View Pricing, Inventory, Delivery & Lifecycle Information:

TT Electronics:

[OPB482P11](#) [OPB470N11](#) [OPB461T11](#) [OPB473L11](#) [OPB460L11](#) [OPB470T11](#) [OPB461L11](#) [OPB471T11](#)
[OPB463P11](#) [OPB473N11](#) [OPB472L11](#) [OPB473T11](#) [OPB472P11](#) [OPB460N11](#) [OPB463L11](#) [OPB460T11](#)
[OPB472N11](#) [OPB462P11](#) [OPB462T11](#) [OPB461N11](#) [OPB471P11](#) [OPB460P11](#) [OPB462N11](#) [OPB462L11](#)
[OPB463T11](#) [OPB473P11](#) [OPB463N11](#) [OPB471N11](#) [OPB461P11](#) [OPB471L11](#) [OPB470P11](#) [OPB472T11](#)