

research and design investment. The BSC9131 and BSC9132 SoCs also include the MAPLE block for hardware acceleration of common DSP functions such as fast Fourier transform, discrete Fourier transform and turbo Viterbi decoding.

The QorIQ Qonverge line of products has a proven set of hardware and software tools for code development and debug. The CodeWarrior Development Studio is a comprehensive integrated development environment (IDE) that provides a highly visual and automated framework to accelerate the development of the most complex embedded applications. The CodeWarrior tools allow a consistent look and feel for developing code on both cores as opposed to competing solutions that may require multiple debugging platforms. In addition to the IDE, the BSC9131RDB and BSC9132QDS give you the ability to develop and test code on hardware systems before developing your own hardware solution.



QorIQ Qonverge BSC9131 Reference Design Board



QorIQ Qonverge BSC9132 Development Board



QorIQ Qonverge BSC9131 SoC Block Diagram

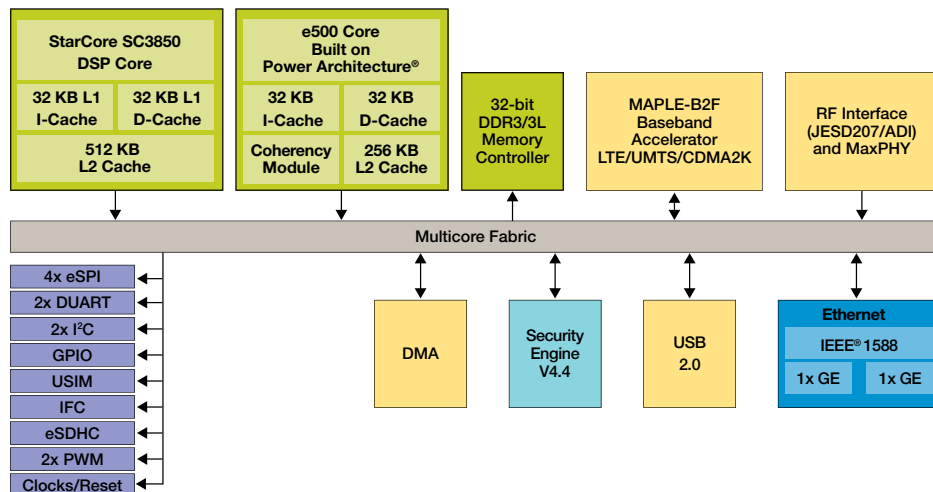

QorIQ Qonverge BSC9131 and BSC9132 Comparison Chart

	BSC9131	BSC9132
GPP	1 x e500, 256 KB L2 up to 1 GHz	2 x e500, 512 KB shared L2 up to 1.2 GHz
DSP/Starcore	1 x SC3850 with 512 KB L2 cache up to 1 GHz	2 x SC3850 each with 512 KB L2 cache, up to 1.2 GHz
DSP hardware accelerators	1 x MAPLE B2F array FFT, convolution, Viterbi Turbo, Filtering, CRC	1 x MAPLE B2P array FFT, convolution, Viterbi Turbo, Filtering, CRC
Memory	1 x DDR3, 32-bit (16-bit mode only with ECC), up to 800 MHz	2 x DDR3, 32-bit (40-bit including ECC), up to 1333 MHz
Flash	NOR, NAND and FPGA integrated	NOR, NAND and FPGA integrated
Trust architecture secure boot	Yes	Yes
SEC hardware encryption	SEC v4.4	SEC v4.4
Pulse width modulators	2	2
GigE with integrated 1588v2	2	2
USB	1 x 2.0	1 x 2.0
PCIe	No	Yes
TDM	1	2
CPRI	No	Yes
JESD207	3: - 2 dual, 1 single lane	4: - 3 dual, 1 single lane
Other interfaces	UART, SPI, eSDHC, USIM, and I ² C controller	UART, SPI, eSDHC, USIM, and I ² C controller

For more information about the QorIQ Qonverge BSC series, visit freescale.com/QorIQQonverge

Freescale, the Freescale logo, CodeWarrior, QorIQ, QorIQ Qonverge and StarCore are trademarks of Freescale Semiconductor, Inc., Reg. U.S. Pat. & Tm. Off. All other product or service names are the property of their respective owners. © 2014 Freescale Semiconductor, Inc.

Document Number: BSC913xNW Rev 0

Mouser Electronics

Authorized Distributor

Click to View Pricing, Inventory, Delivery & Lifecycle Information:

[NXP:](#)

[BSC9131NJE1HHHB](#) [BSC9131NLE1HHHB](#) [BSC9131NLN1HHHB](#) [BSC9131NSE1KHKB](#) [BSC9131NSN1KHKB](#)
[BSC9131NXE1KHKB](#) [BSC9131NXN1KHKB](#)