

CONNECTOR

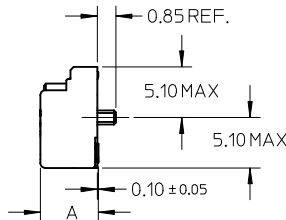

NOTES:

1. MATERIALS: HOUSING:LCP COLOR:BLACK UL94V-0
CONTACT:PHOSPHOR BRONZE
NAIL:BRASS
2. FINISH: CONTACT:SELECTIVE GOLD IN CONTACT AND SOLDER AREA
UNDERPLATED:NICKEL OVERALL
NAIL:TIN IN SOLDER AREA
UNDERPLATED:NICKEL OVERALL
3. THE MODULE CARD REFERENCE MINIPCI-E CARD
ELECTROMECHANICAL SPECIFICATION
4. DATUM D IS THE TOP OF SURFACE OF PCB
5. MATCHED LATCH 48099**** SERIES.
6. PART 67910**** COMPLIANT TO ROHS DIRECTIVE 2002/95/EC
AND ELV DIRECTIVE 2000/53/EC.

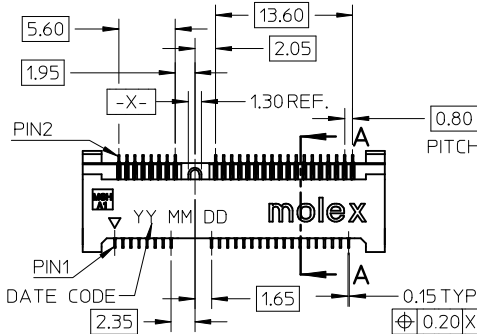
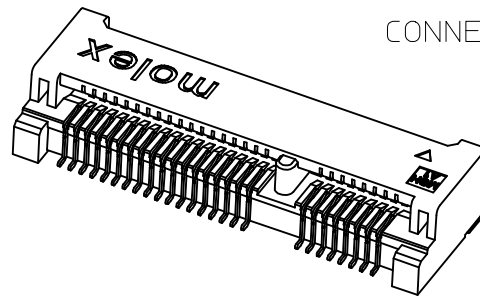
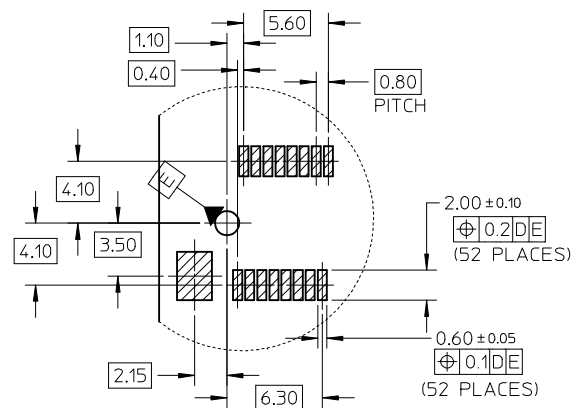

DETAIL 1

Scale 3:1

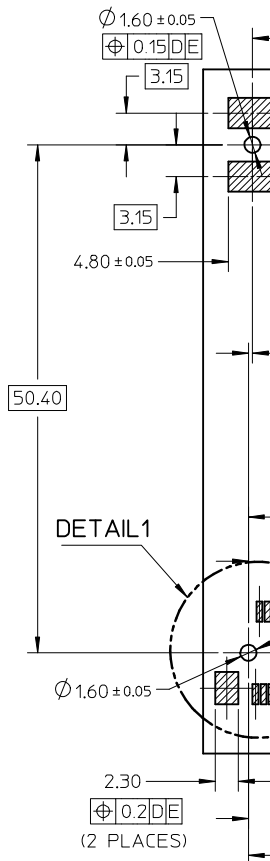

DETAIL 1

RECOMM

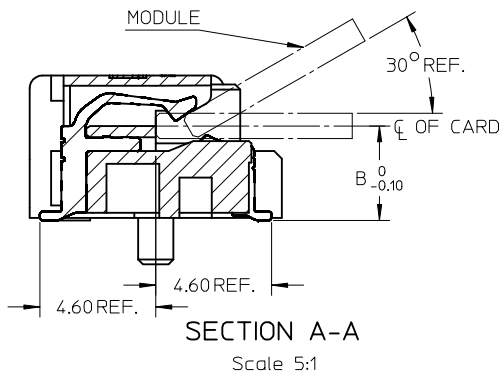

SECTION A-A

Scale 5:1

| | | | | | | | | |
|--|-------------------------------|--|-------|-----------------|----|---|----------------------------|---|
| REVISED EC NO: SH2009-0388 DR: WINEZHAO CHKD: APPR: HAWANG 2008/12/03 2008/12/04 2008/12/09 | QUALITY SYMBOLS ▽=0 ◻=0 | GENERAL TOLERANCES (UNLESS SPECIFIED) | | DIMENSION STYLE | | DRAWN BY DAVID HU CHECKED BY HARVEY APPROVED BY GARY 2005/09/22 DATE 2005/10/26 DATE 2005/10/26 | DIMENSION STYLE MM ONLY | TITLE SEE SHEET 1 THIS DRAWING CONTAINS INCORPORATED AND SHOU |
| | | | mm | INCH | | | | |
| | | 4 PLACES | ± --- | ± --- | | | | |
| | | 3 PLACES | ± --- | ± --- | | | | |
| | 2 PLACES | ± 0.25 | ± --- | | | | | |
| | 1 PLACE | ± 0.25 | ± --- | | | | | |
| | | ANGULAR ± 3 ° | | | | | | |
| | | DRAFT WHERE APPLICABLE MUST REMAIN WITHIN DIMENSIONS | | | | | | |
| D | REV | | | SIZE | A3 | | | |

NOTES:
1. PIN NUMBER

2. COMPONENT
KEEP OUT
3. COMPONENT

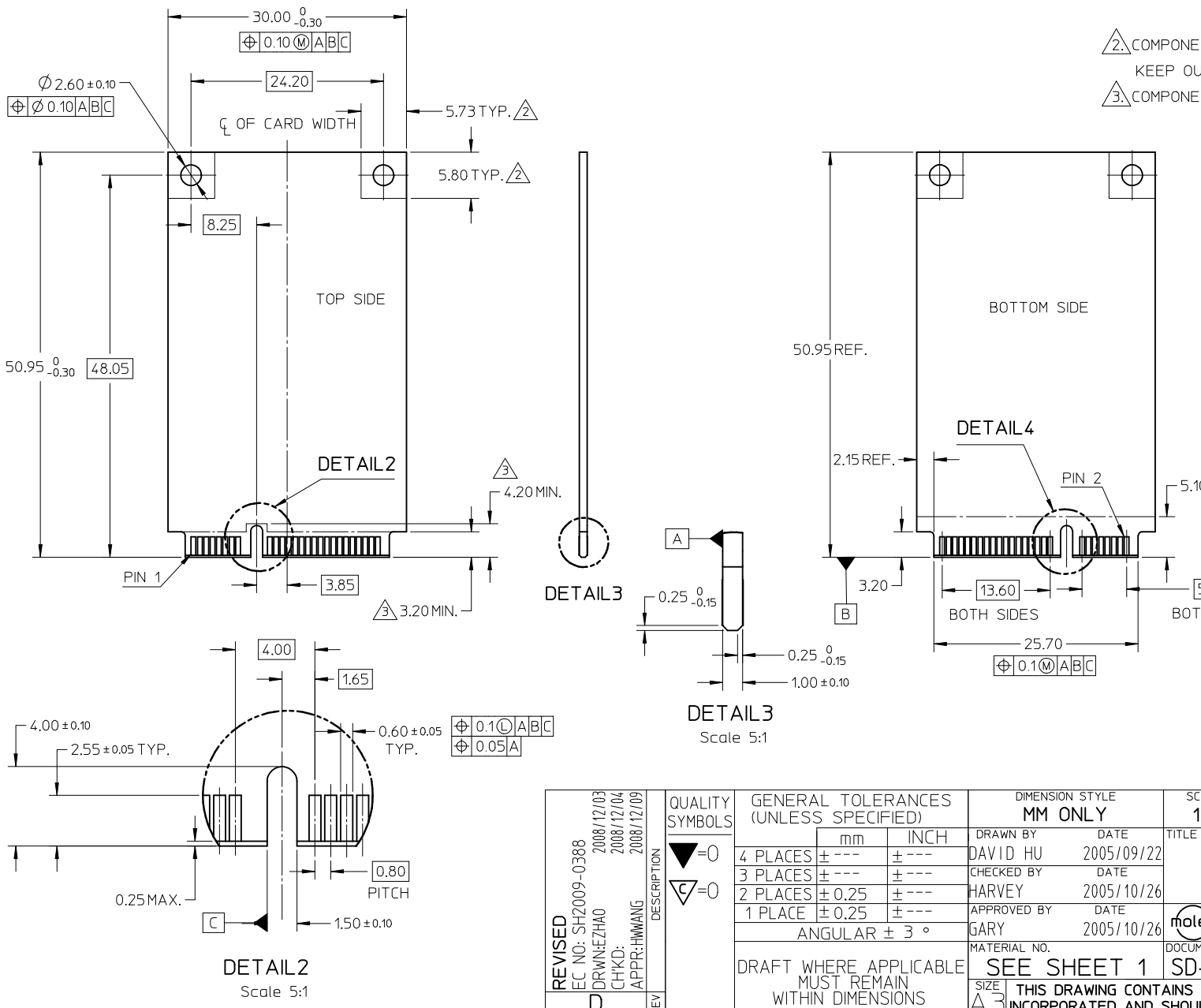

| | | | | | | | | |
|--|-------------|-----------------|-----|--|-----------------|-------------------------|------------|-----------------------|
| REVISED EC NO: SH2009-0388 DR: WNEZHAO CHKD: APPR: HWANG | DESCRIPTION | QUALITY SYMBOLS | | GENERAL TOLERANCES (UNLESS SPECIFIED) | DIMENSION STYLE | | SCALE | |
| | | ▽=0 | ∇=0 | | MM ONLY | | | 1: |
| D | REV | 4 PLACES | | mm | INCH | DRAWN BY | DATE | TITLE |
| | | 3 PLACES | | ± --- | ± --- | DAVID HU | 2005/09/22 | |
| | | 2 PLACES | | ± 0.25 | ± --- | CHECKED BY | DATE | |
| | | 1 PLACE | | ± 0.25 | ± --- | HARVEY | 2005/10/26 | |
| | | | | ANGULAR ± 3 ° | | APPROVED BY | DATE | |
| | | | | DRAFT WHERE APPLICABLE MUST REMAIN WITHIN DIMENSIONS | | GARY | 2005/10/26 | |
| | | | | MATERIAL NO. | | SEE SHEET 1 | | SD- |
| | | | | SIZE | | THIS DRAWING CONTAINS 1 | | INCORPORATED AND SHOU |
| | | | | A3 | | | | |

Mouser Electronics

Authorized Distributor

Click to View Pricing, Inventory, Delivery & Lifecycle Information:

[Molex:](#)

[67910-5700](#)