

Pin Description

Pin # (BQSOP)	Pin # (TQFN)	Pin Name ^(1,2)	Description
2, 4, 12, 21, 23, 25, 36, 48	2, 8, 16, 18, 20, 30, 40, 42	V _{DD}	+ Power supply 3.30
1, 3, 5, 8, 11, 14, 17, 20, 22, 24, 26, 31, 37, 42, 47	1, 5, 10, 13, 17, 19, 21, 39, 41	V _{SS}	- Power supply
13	9	SEL	Select pin, see truth table
6, 7, 9, 10, 15, 16, 18, 19, 27-30, 32-35, 38-41, 43-46	3, 4, 6, 7, 11, 12, 14, 15, 22-29, 31-38,	Dx ^{+/-n}	Data + Clk bits for TMDS signal

Notes:

1. x = 0,1,2,3
2. n = A or B

Truth Table⁽¹⁾

Function	SEL
Dx to Dx ^A	L
Dx to Dx ^B	H

Notes:

1. x = 0,1,2,3

Maximum Ratings

(Above which useful life may be impaired. For user guidelines, not tested.)

Storage Temperature.....	-65°C to +150°C
Supply Voltage to V _{SS} Potential.....	-0.5V to +2.5V
DC Input Voltage	V _{SS} to V _{DD}
DC Output Current.....	120mA

Note: Stresses greater than those listed under MAXIMUM RATINGS may cause permanent damage to the device. This is a stress rating only and functional operation of the device at these or any other conditions above those indicated in the operational sections of this specification is not implied. Exposure to absolute maximum rating conditions for extended periods may affect reliability.

DC Power Supply Characteristics

Parameter	Description	Min.	Max.	Units
V _{DD}	Positive Power Supply	3.0	3.6	V
V _{SS}	Negative Power Supply	1.5	1.6	V

DC Electrical Characteristics for Switching over Operating Range (T_A = -40°C to +85°C)

Parameter	Description	Test Conditions ⁽¹⁾	Min.	Typ. ⁽²⁾	Max.	Units
V _{IH} ⁽³⁾	Input HIGH Voltage	Guaranteed HIGH level	0.65(V _{DD} -V _{SS})+V _{SS}			V
V _{IL} ⁽³⁾	Input LOW Voltage	Guaranteed LOW level	-0.5+V _{SS}		0.35(V _{DD} -V _{SS})+V _{SS}	
V _{IK}	Clamp Diode Voltage	V _{DD} =Max., I _{IN} =-18mA		-0.7+V _{SS}	-1.2+V _{SS}	
I _{IH}	Input HIGH Current	V _{DD} =Max., V _{IN} =V _{DD}			±5	µA
I _{IL}	Input LOW Current	V _{DD} =Max., V _{IN} =V _{SS}			±5	

Notes:

1. For Max. or Min. conditions, use appropriate value specified under Electrical Characteristics for the applicable device type.
2. Typical values are at T_A = 25°C ambient and maximum loading.
3. V_{IH} & V_{IL} are for SEL input only.

Power Supply Characteristics

Parameters	Description	Test Conditions ⁽¹⁾	Min.	Typ. ⁽²⁾	Max.	Units
I _{DD}	Quiescent Power Supply Current	V _{DD} = Max., V _{IN} = V _{DD} or V _{SS}		200		μA

Notes:

1. For Max. or Min. conditions, use appropriate value specified under Electrical Characteristics for the applicable device type.
2. Typical values are at T_A = 25°C ambient and maximum loading.

Dynamic Electrical Characteristics Over the Operating Range (T_A = -40° to +85°C)

Parameter	Description	Test Conditions	Min.	Typ.	Max.	Units
X _{TALK}	Crosstalk	See Fig. 1 for Measurement Setup, @ 1.65 Gbps		-36		dB
O _{IRR}	OFF Isolation	See Fig. 2 for Measurement Setup, @ 1.65 Gbps		-35		
BW	-3db Bandwidth			1.5		GHz

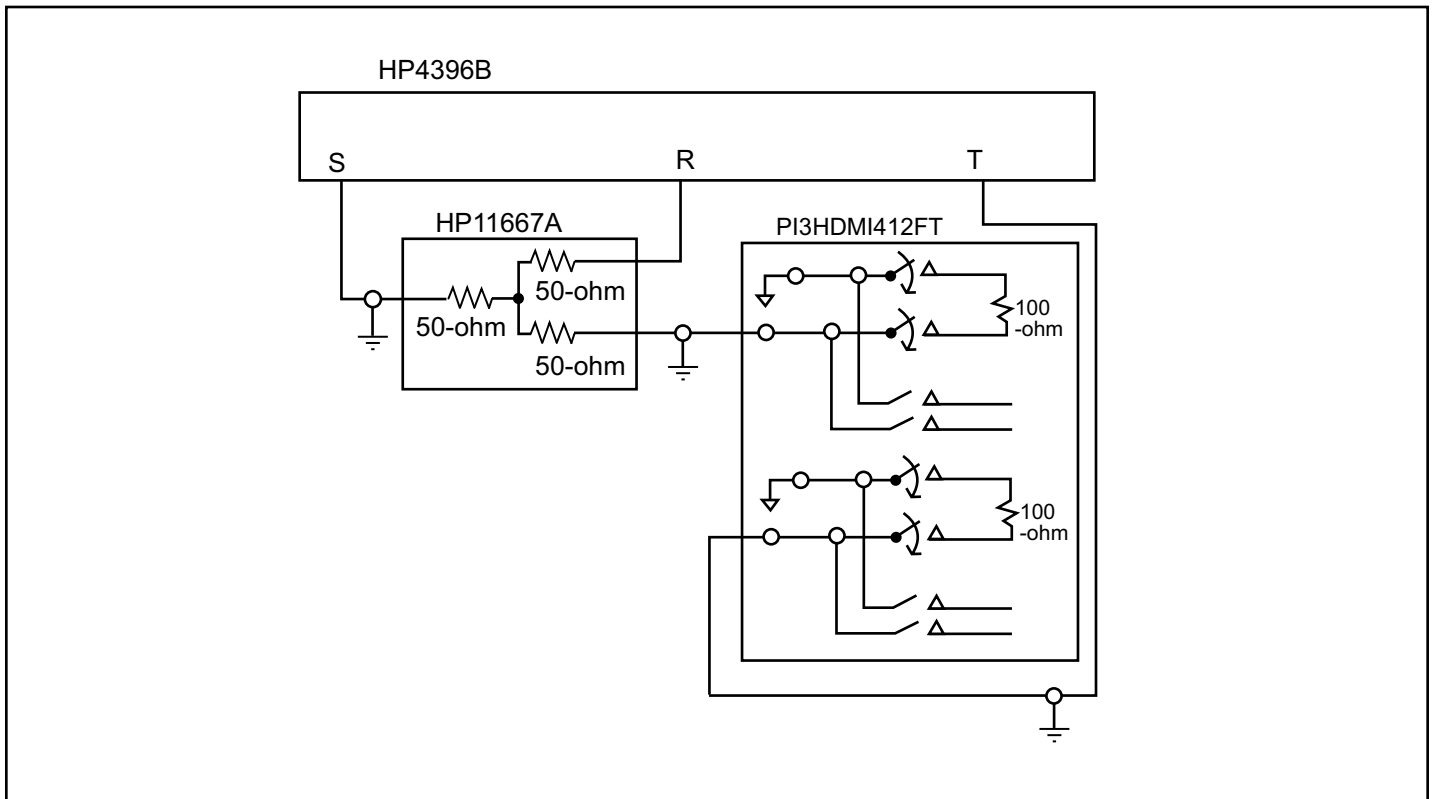

Fig 1. Crosstalk Setup

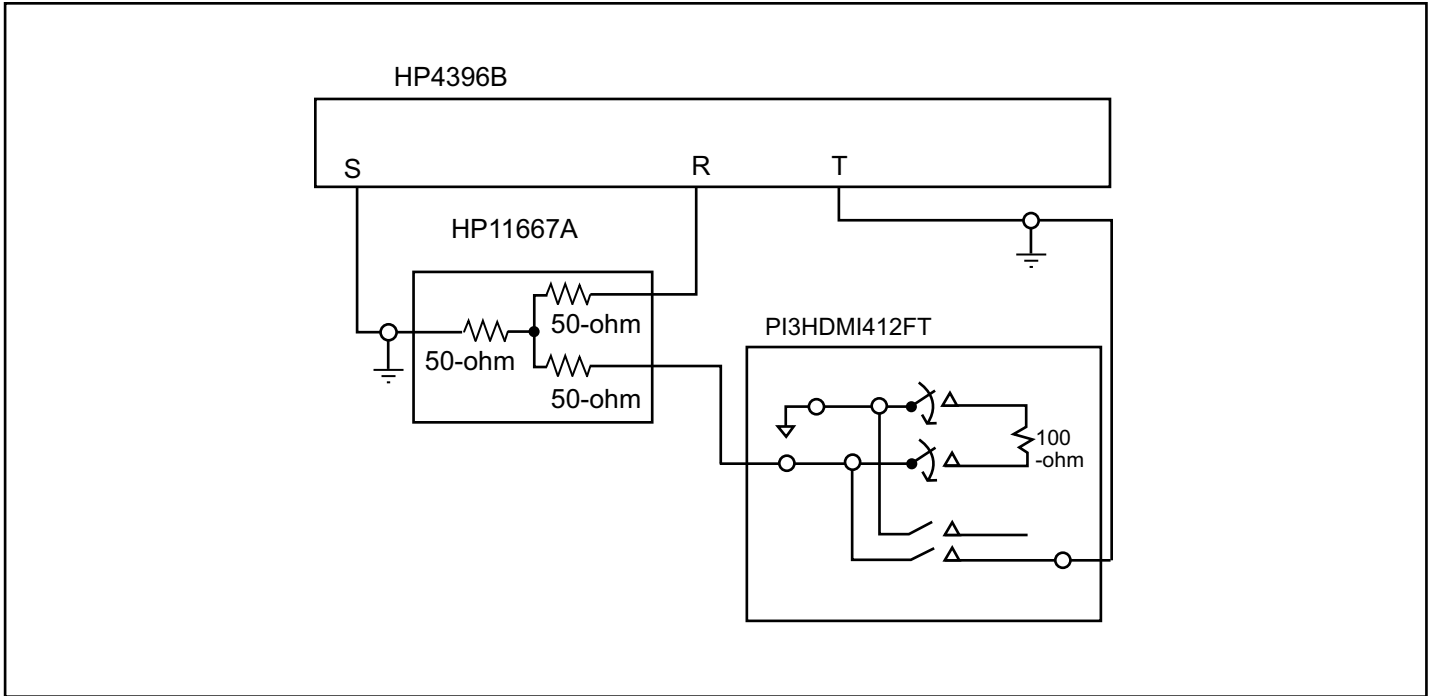

Fig 2. Off-isolation setup

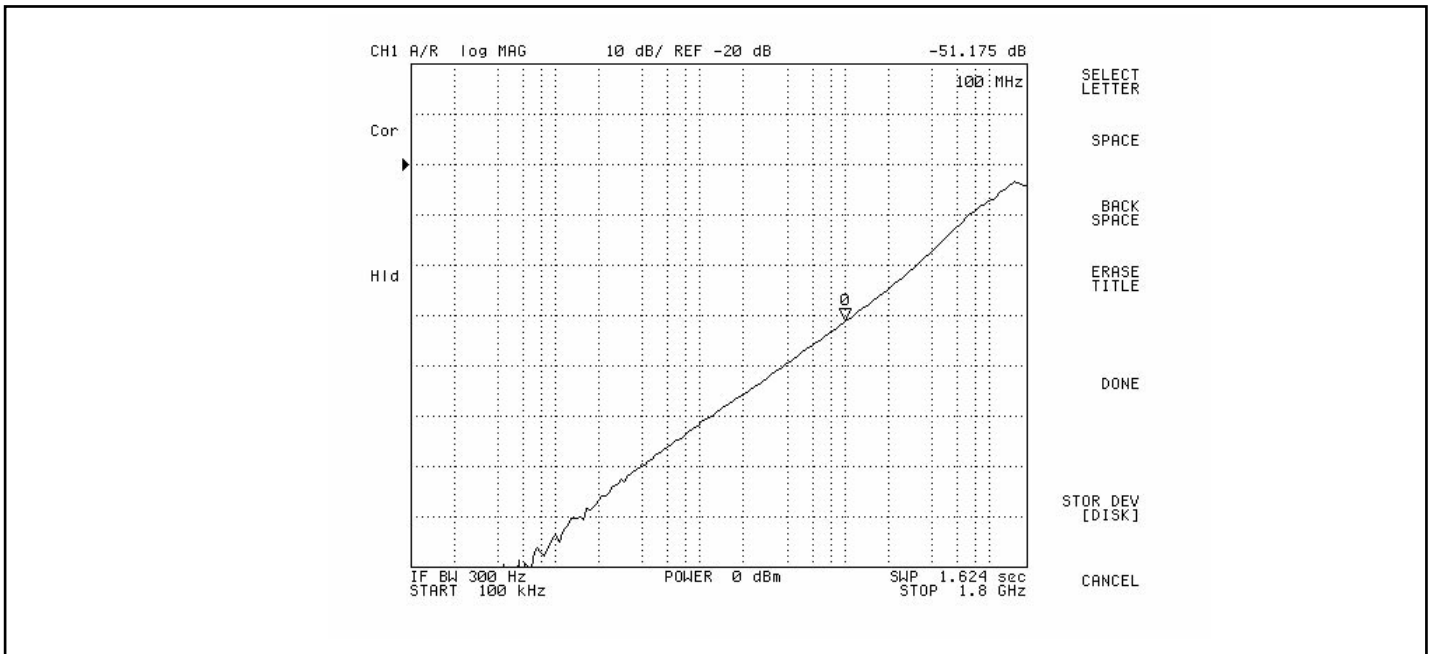

Fig 3. Crosstalk

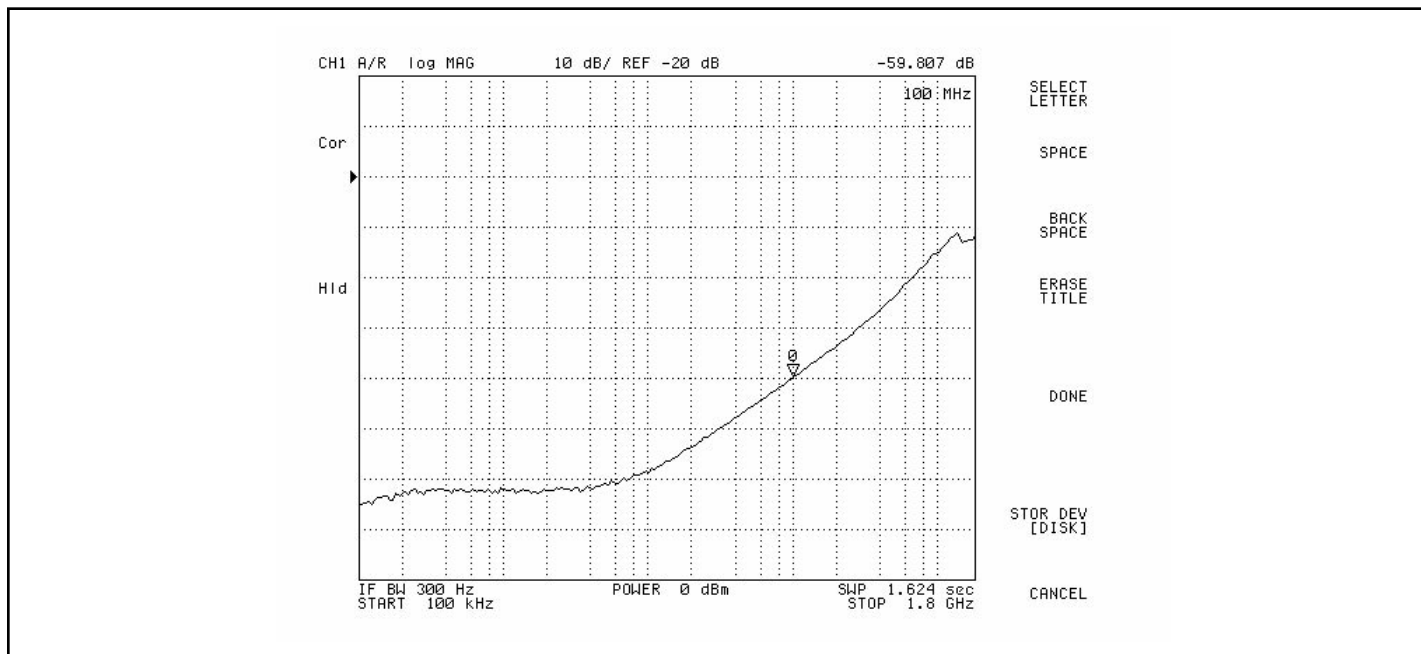

Fig 4. Off Isolation

Switching Characteristics ($T_A = -40^\circ$ to $+85^\circ\text{C}$, $V_{SS} = 0\text{V}$, $V_{DD} = 1.8\text{V} \pm 10\%$)

Parameter	Description	Min.	Max.	Units
t_{PZH} , t_{PZL}	Line Enable Time - SEL to $Dx^{+/-A}$, $Dx^{+/-B}$ (1)	0.5	8.0	ns
t_{PHZ} , t_{PLZ}	Line Disable Time - SEL to $Dx^{+/-A}$, $Dx^{+/-B}$ (1)	0.5	4.0	

Notes:

1. For measurement setup, please see "Test Circuit For Electrical Characteristic" on page 6, and "Switching waveforms" on page 7

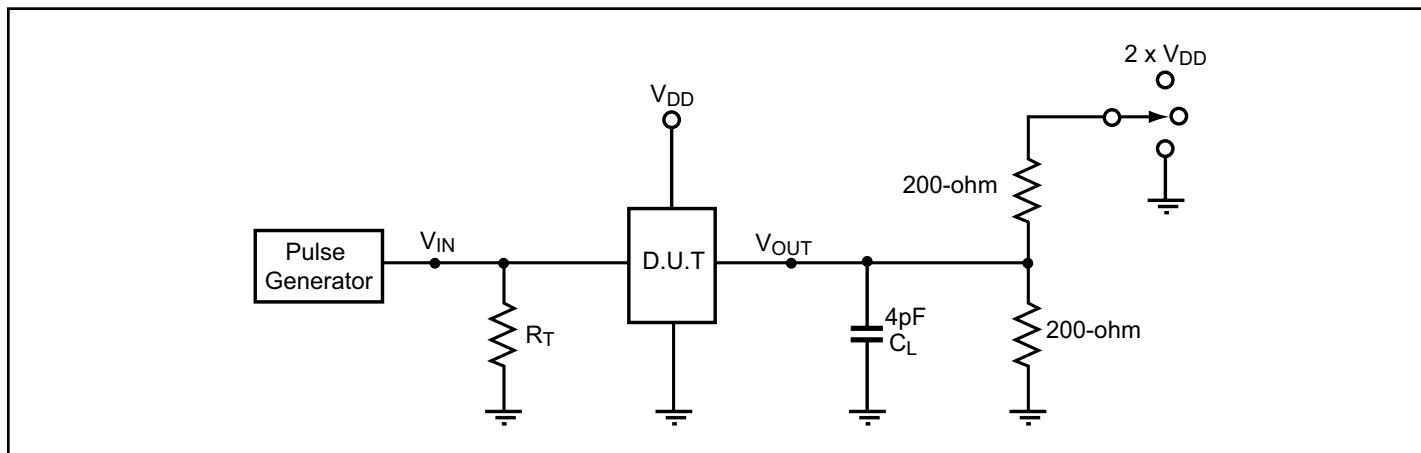
Test Circuit for Electrical Characteristics

Notes:

1. C_L = Load capacitance: includes jig and probe capacitance.
2. R_T = Termination resistance: should be equal to Z_{OUT} of the Pulse Generator
3. Waveform 1 is for an output with internal conditions such that the output is low except when disabled by the output control. Waveform 2 is for an output with internal conditions such that the output is high except when disabled by the output control.
4. All input impulses are supplied by generators having the following characteristics: $PRR \leq \text{MHz}$, $Z_O = 50\Omega$, $t_R \leq 2.5\text{ns}$, $t_F \leq 2.5\text{ns}$.
5. The outputs are measured one at a time with one transition per measurement.

Switch Positions

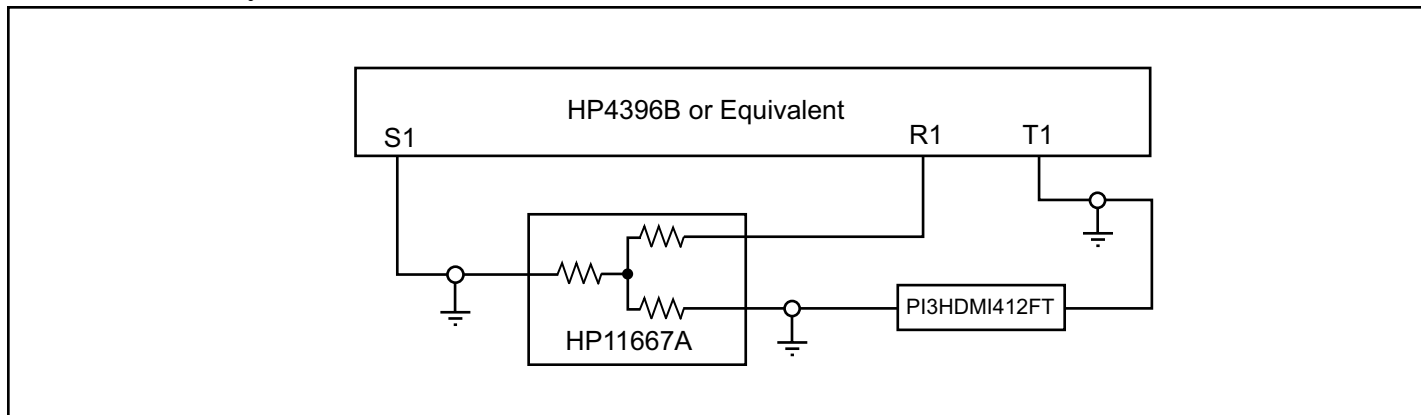
Test	Switch
t_{PLZ} , t_{PZL} (output on B-side)	$2 \times (V_{DD} - V_{SS})$
t_{PHZ} , t_{PZH} (output on B-side)	V_{SS}
Prop Delay	Open

Test Circuit for Dynamic Electrical Characteristics

Switching Waveforms

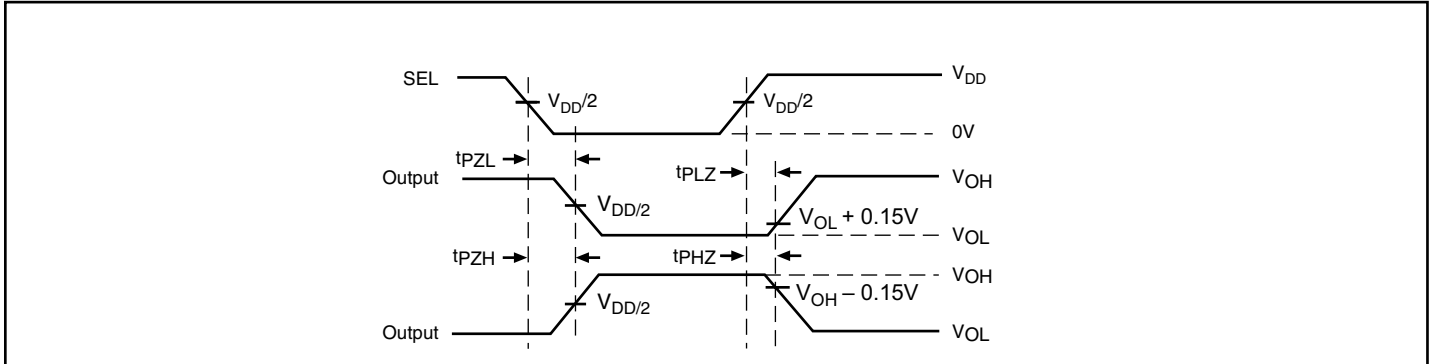

Voltage Waveforms Enable and Disable Times

Application Information

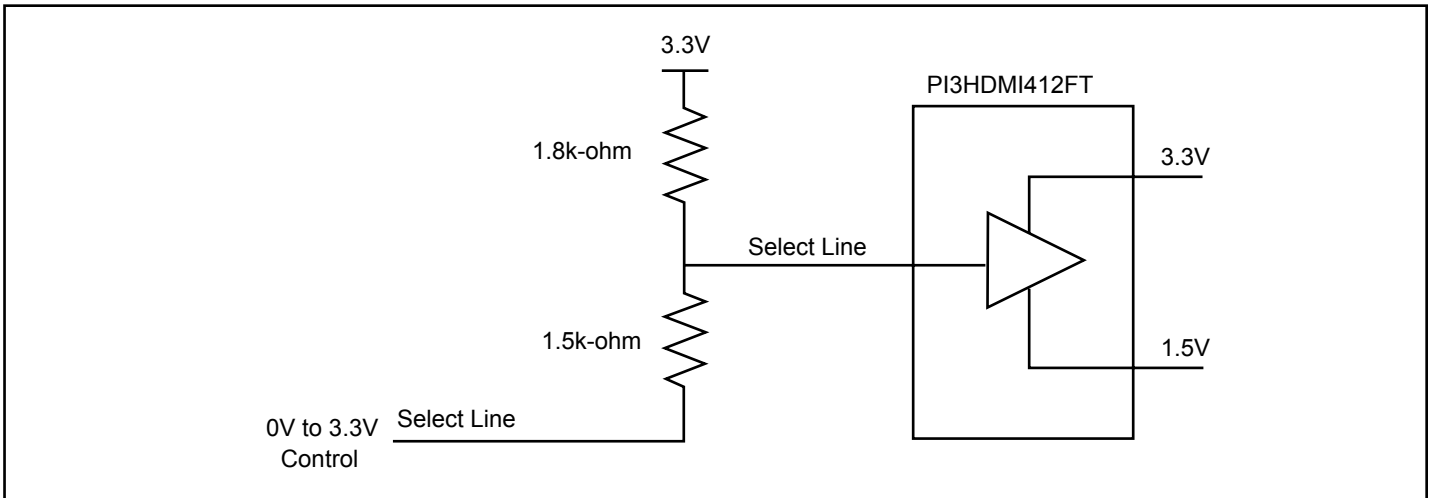

Example of a circuit that needs to be connected to the SEL pin

Eye Diagram Measurements

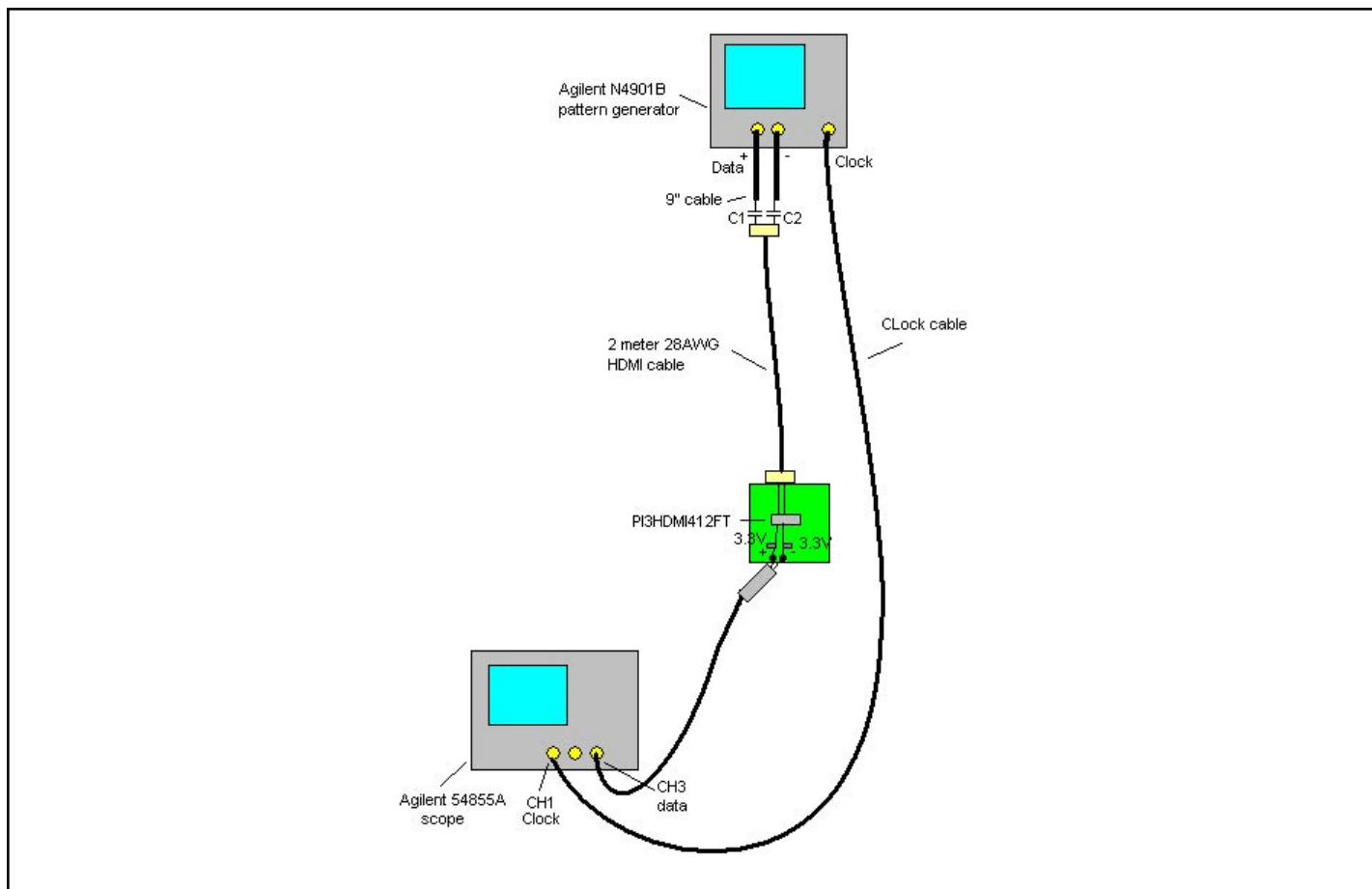

TP3(Rx) Test Setup

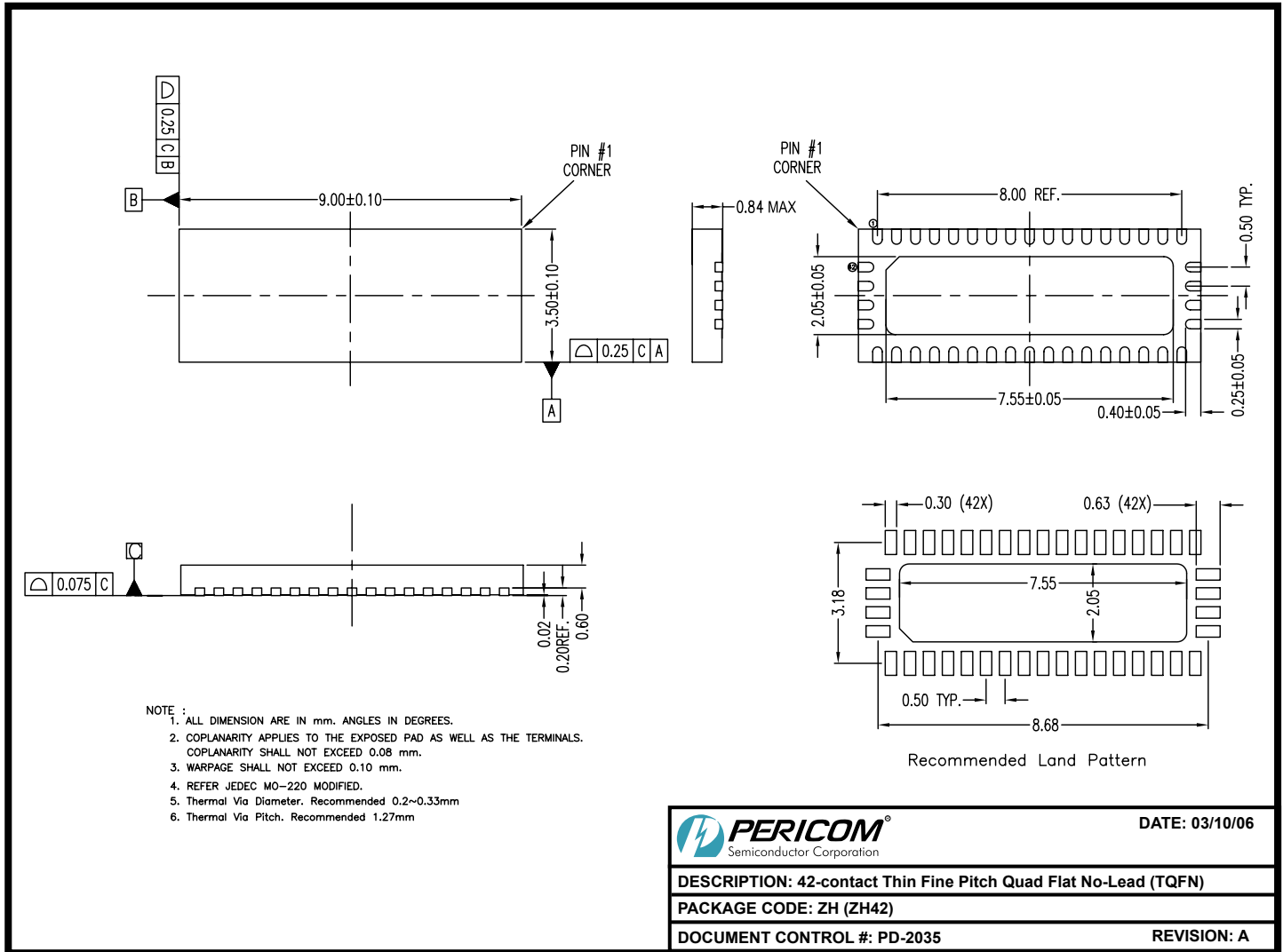

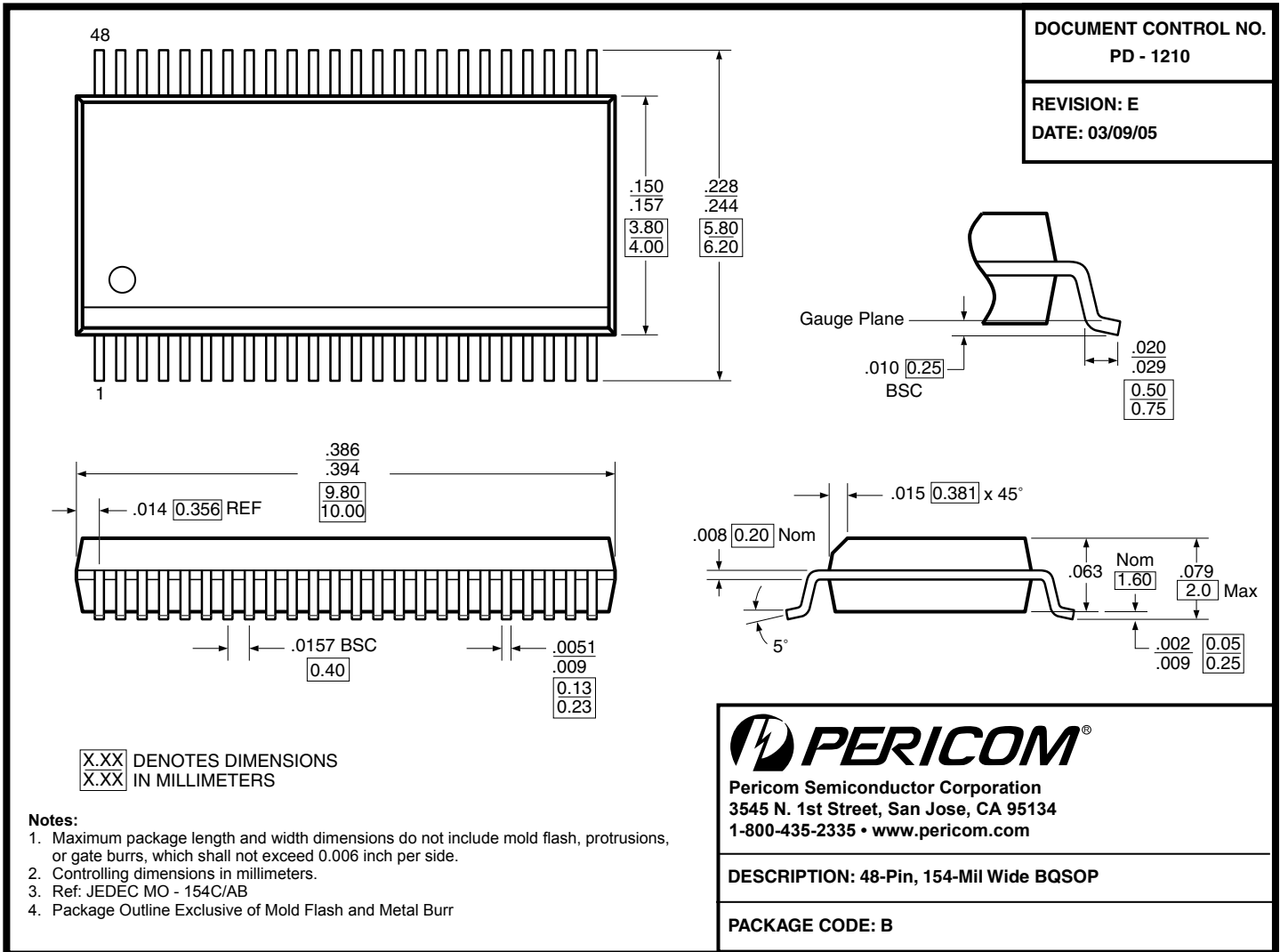

Ordering Information

Ordering Code	Package Code	Package Description
PI3HDMI412FTZHE	ZH	Pb-free & Green, 42-pin TQFN
PI3HDMI412FTBE	B	Pb-free & Green, 48-pin BQSOP

Notes:

- Thermal characteristics can be found on the company web site at www.pericom.com/packaging/
- E = Pb-free and Green
- Adding an X suffix = Tape and Reel

Mouser Electronics

Authorized Distributor

Click to View Pricing, Inventory, Delivery & Lifecycle Information:

[Diodes Incorporated:](#)

[PI3HDMI412FTBEX](#) [PI3HDMI412FTBE](#) [PI3HDMI412FTZHEX](#) [PI3HDMI412FTZHE](#)