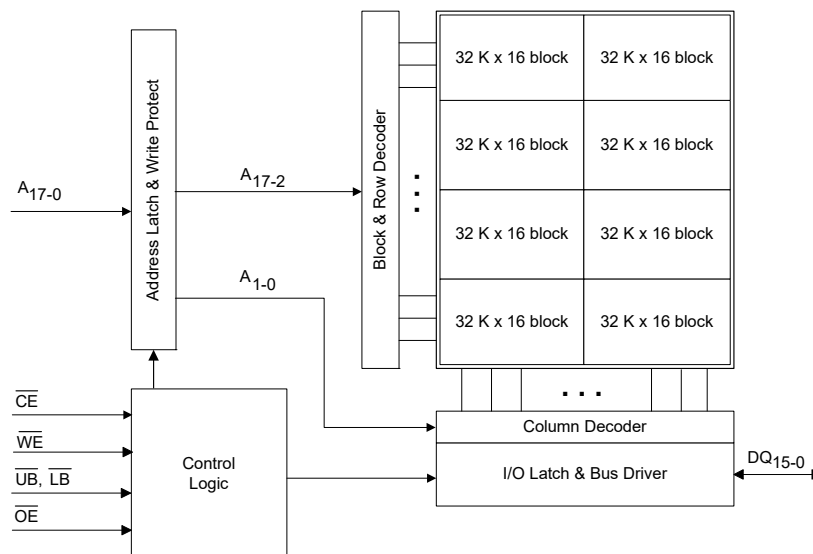


## Features

- 4-Mbit ferroelectric random access memory (F-RAM) logically organized as 256K × 16
  - Configurable as 512K × 8 using  $\overline{UB}$  and  $\overline{LB}$
  - High-endurance 100 trillion ( $10^{14}$ ) read/writes
  - 151-year data retention (see [Data Retention and Endurance on page 10](#))
  - NoDelay™ writes
  - Page mode operation to 25 ns cycle time
  - Advanced high-reliability ferroelectric process
- SRAM compatible
  - Industry-standard 256K × 16 SRAM pinout
  - 55 ns access time, 110 ns cycle time
- Advanced features
  - Software-programmable block write-protect
- Superior to battery-backed SRAM modules
  - No battery concerns
  - Monolithic reliability
  - True surface mount solution, no rework steps
  - Superior for moisture, shock, and vibration
- Low power consumption
  - Active current 8 mA (typ)
  - Standby current 90 μA (typ)
- Low-voltage operation:  $V_{DD} = 2.7\text{ V to }3.6\text{ V}$
- Industrial temperature:  $-40\text{ °C to }+85\text{ °C}$
- 48-ball fine-pitch ball grid array (FBGA) package
- Restriction of hazardous substances (RoHS) compliant

## Logic Block Diagram



## Functional Description

The FM22LD16 is a 256K × 16 nonvolatile memory that reads and writes similar to a standard SRAM. A ferroelectric random access memory or F-RAM is nonvolatile, which means that data is retained after power is removed. It provides data retention for over 151 years while eliminating the reliability concerns, functional disadvantages, and system design complexities of battery-backed SRAM (BBSRAM). Fast write timing and high write endurance make the F-RAM superior to other types of memory.

The FM22LD16 operation is similar to that of other RAM devices and therefore, it can be used as a drop-in replacement for a standard SRAM in a system. Read and write cycles may be triggered by CE or simply by changing the address. The F-RAM memory is nonvolatile due to its unique ferroelectric memory process. These features make the FM22LD16 ideal for nonvolatile memory applications requiring frequent or rapid writes.

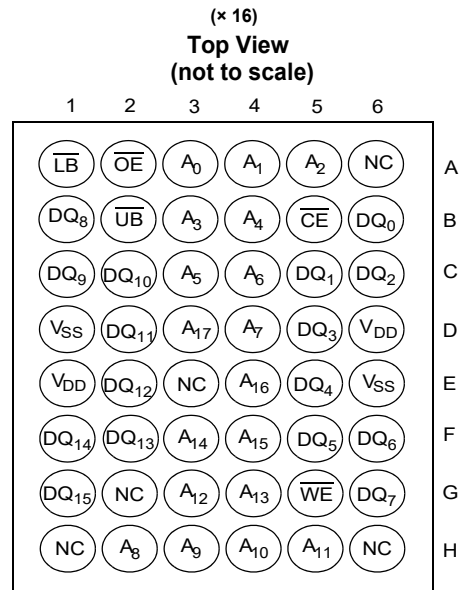
The FM22LD16 includes a low voltage monitor that blocks access to the memory array when  $V_{DD}$  drops below  $V_{DD\text{ min}}$ . The memory is protected against an inadvertent access and data corruption under this condition. The device also features software-controlled write protection. The memory array is divided into 8 uniform blocks, each of which can be individually write protected.

The device is available in a 48-ball FBGA package. Device specifications are guaranteed over the industrial temperature range  $-40\text{ °C to }+85\text{ °C}$ .

For a complete list of related documentation, click [here](#).

## Contents

<b>Pinout</b> .....	<b>3</b>	<b>AC Switching Characteristics</b> .....	<b>11</b>
<b>Pin Definitions</b> .....	<b>3</b>	SRAM Read Cycle .....	11
<b>Device Operation</b> .....	<b>4</b>	SRAM Write Cycle .....	12
Memory Operation .....	4	<b>Power Cycle and Sleep Mode Timing</b> .....	<b>16</b>
Read Operation .....	4	<b>Functional Truth Table</b> .....	<b>17</b>
Write Operation .....	4	<b>Ordering Information</b> .....	<b>18</b>
Page Mode Operation .....	4	Ordering Code Definitions .....	18
Pre-charge Operation .....	4	<b>Package Diagram</b> .....	<b>19</b>
Software Write Protect .....	4	<b>Acronyms</b> .....	<b>20</b>
Software Write-Protect Timing .....	7	<b>Document Conventions</b> .....	<b>20</b>
SRAM Drop-In Replacement .....	8	Units of Measure .....	20
<b>Maximum Ratings</b> .....	<b>9</b>	<b>Document History Page</b> .....	<b>21</b>
<b>Operating Range</b> .....	<b>9</b>	<b>Sales, Solutions, and Legal Information</b> .....	<b>22</b>
<b>DC Electrical Characteristics</b> .....	<b>9</b>	Worldwide Sales and Design Support .....	22
<b>Data Retention and Endurance</b> .....	<b>10</b>	Products .....	22
<b>Capacitance</b> .....	<b>10</b>	PSoC® Solutions .....	22
<b>Thermal Resistance</b> .....	<b>10</b>	Cypress Developer Community .....	22
<b>AC Test Conditions</b> .....	<b>10</b>	Technical Support .....	22

**Pinout**
**Figure 1. 48-ball FBGA pinout**

**Pin Definitions**

Pin Name	I/O Type	Description
A <sub>17</sub> –A <sub>0</sub>	Input	<b>Address inputs:</b> The 18 address lines select one of 262,144 words in the F-RAM array. The lowest two address lines A <sub>1</sub> –A <sub>0</sub> may be used for page mode read and write operations.
DQ <sub>15</sub> –DQ <sub>0</sub>	Input/Output	<b>Data I/O Lines:</b> 16-bit bidirectional data bus for accessing the F-RAM array.
WE	Input	<b>Write Enable:</b> A write cycle begins when WE is asserted. The rising edge causes the FM22LD16 to write the data on the DQ bus to the F-RAM array. The falling edge of WE latches a new column address for page mode write cycles.
CE	Input	<b>Chip Enable:</b> The device is selected and a new memory access begins on the falling edge of CE. The entire address is latched internally at this point. Subsequent changes to the A <sub>1</sub> –A <sub>0</sub> address inputs allow page mode operation.
OE	Input	<b>Output Enable:</b> When OE is LOW, the FM22LD16 drives the data bus when the valid read data is available. Deasserting OE HIGH tristates the DQ pins.
UB	Input	<b>Upper Byte Select:</b> Enables DQ <sub>15</sub> –DQ <sub>8</sub> pins during reads and writes. These pins are HI-Z if UB is HIGH. If the user does not perform byte writes and the device is not configured as a 512K × 8, the UB and LB pins may be tied to ground.
LB	Input	<b>Lower Byte Select:</b> Enables DQ <sub>7</sub> –DQ <sub>0</sub> pins during reads and writes. These pins are HI-Z if LB is HIGH. If the user does not perform byte writes and the device is not configured as a 512K × 8, the UB and LB pins may be tied to ground.
V <sub>SS</sub>	Ground	Ground for the device. Must be connected to the ground of the system.
V <sub>DD</sub>	Power supply	Power supply input to the device.
NC	No connect	No connect. This pin is not connected to the die.

## Device Operation

The FM22LD16 is a word wide F-RAM memory logically organized as  $262,144 \times 16$  and accessed using an industry-standard parallel interface. All data written to the part is immediately nonvolatile with no delay. The device offers page mode operation, which provides high-speed access to addresses within a page (row). Access to a different page requires that either  $\overline{CE}$  transitions LOW or the upper address ( $A_{17}-A_2$ ) changes. See the [Functional Truth Table on page 17](#) for a complete description of read and write modes.

## Memory Operation

Users access 262,144 memory locations, each with 16 data bits through a parallel interface. The F-RAM array is organized as eight blocks, each having 8192 rows. Each row has four column locations, which allow fast access in page mode operation. When an initial address is latched by the falling edge of  $\overline{CE}$ , subsequent column locations may be accessed without the need to toggle  $\overline{CE}$ . When  $\overline{CE}$  is deasserted HIGH, a pre-charge operation begins. Writes occur immediately at the end of the access with no delay. The  $\overline{WE}$  pin must be toggled for each write operation. The write data is stored in the nonvolatile memory array immediately, which is a feature unique to F-RAM called NoDelay writes.

## Read Operation

A read operation begins on the falling edge of  $\overline{CE}$ . The falling edge of  $\overline{CE}$  causes the address to be latched and starts a memory read cycle if  $\overline{WE}$  is HIGH. Data becomes available on the bus after the access time is met. When the address is latched and the access completed, a new access to a random location (different row) may begin while  $\overline{CE}$  is still LOW. The minimum cycle time for random addresses is  $t_{RC}$ . Note that unlike SRAMs, the FM22LD16's  $\overline{CE}$ -initiated access time is faster than the address access time.

The FM22LD16 will drive the data bus when  $\overline{OE}$  and at least one of the byte enables ( $\overline{UB}$ ,  $\overline{LB}$ ) is asserted LOW. The upper data byte is driven when  $\overline{UB}$  is LOW, and the lower data byte is driven when  $\overline{LB}$  is LOW. If  $\overline{OE}$  is asserted after the memory access time is met, the data bus will be driven with valid data. If  $\overline{OE}$  is asserted before completing the memory access, the data bus will not be driven until valid data is available. This feature minimizes supply current in the system by eliminating transients caused by invalid data being driven to the bus. When  $\overline{OE}$  is deasserted HIGH, the data bus will remain in a HI-Z state.

## Write Operation

In the FM22LD16, writes occur in the same interval as reads. The FM22LD16 supports both  $\overline{CE}$  and  $\overline{WE}$  controlled write cycles. In both cases, the address  $A_{17}-A_2$  is latched on the falling edge of  $\overline{CE}$ .

In a  $\overline{CE}$ -controlled write, the  $\overline{WE}$  signal is asserted before beginning the memory cycle. That is,  $\overline{WE}$  is LOW when  $\overline{CE}$  falls. In this case, the device begins the memory cycle as a write. The FM22LD16 will not drive the data bus regardless of the state of  $\overline{OE}$  as long as  $\overline{WE}$  is LOW. Input data must be valid when  $\overline{CE}$  is

deasserted HIGH. In a  $\overline{WE}$ -controlled write, the memory cycle begins on the falling edge of  $\overline{CE}$ . The  $\overline{WE}$  signal falls some time later. Therefore, the memory cycle begins as a read. The data bus will be driven if  $\overline{OE}$  is LOW; however, it will be HI-Z when  $\overline{WE}$  is asserted LOW. The  $\overline{CE}$ - and  $\overline{WE}$ -controlled write timing cases are shown in the [Figure 11 on page 14](#).

Write access to the array begins on the falling edge of  $\overline{WE}$  after the memory cycle is initiated. The write access terminates on the rising edge of  $\overline{WE}$  or  $\overline{CE}$ , whichever comes first. A valid write operation requires the user to meet the access time specification before deasserting  $\overline{WE}$  or  $\overline{CE}$ . The data setup time indicates the interval during which data cannot change before the end of the write access (rising edge of  $\overline{WE}$  or  $\overline{CE}$ ).

Unlike other nonvolatile memory technologies, there is no write delay with F-RAM. Because the read and write access times of the underlying memory are the same, the user experiences no delay through the bus. The entire memory operation occurs in a single bus cycle. Data polling, a technique used with EEPROMs to determine if a write is complete, is unnecessary.

## Page Mode Operation

The F-RAM array is organized as eight blocks, each having 8192 rows. Each row has four column-address locations. Address inputs  $A_1-A_0$  define the column address to be accessed. An access can start on any column address, and other column locations may be accessed without the need to toggle the  $\overline{CE}$  pin. For fast access reads, after the first data byte is driven to the bus, the column address inputs  $A_1-A_0$  may be changed to a new value. A new data byte is then driven to the DQ pins no later than  $t_{AAP}$ , which is less than half the initial read access time. For fast access writes, the first write pulse defines the first write access. While  $\overline{CE}$  is LOW, a subsequent write pulse along with a new column address provides a page mode write access.

## Pre-charge Operation

The pre-charge operation is an internal condition in which the memory state is prepared for a new access. Pre-charge is user-initiated by driving the  $\overline{CE}$  signal HIGH. It must remain HIGH for at least the minimum pre-charge time,  $t_{PC}$ .

Pre-charge is also activated by changing the upper addresses,  $A_{17}-A_2$ . The current row is first closed before accessing the new row. The device automatically detects an upper order address change, which starts a pre-charge operation. The new address is latched and the new read data is valid within the  $t_{AA}$  address access time; see [Figure 8 on page 13](#). A similar sequence occurs for write cycles; see [Figure 13 on page 14](#). The rate at which random addresses can be issued is  $t_{RC}$  and  $t_{WC}$ , respectively.

## Software Write Protect

The  $256K \times 16$  address space is divided into eight sectors (blocks) of  $32K \times 16$  each. Each sector can be individually software write-protected and the settings are nonvolatile. A unique address and command sequence invokes the write-protect mode.

To modify write protection, the system host must issue six read commands, three write commands, and a final read command.

The specific sequence of read addresses must be provided to access the write-protect mode. Following the read address sequence, the host must write a data byte that specifies the desired protection state of each sector. For confirmation, the system must then write the complement of the protection byte immediately after the protection byte. Any error that occurs including read addresses in the wrong order, issuing a seventh read address, or failing to complement the protection value will leave the write protection unchanged.

The write-protect state machine monitors all addresses, taking no action until this particular read/write sequence occurs. During the address sequence, each read will occur as a valid operation and data from the corresponding addresses will be driven to the data bus. Any address that occurs out of sequence will cause the software protection state machine to start over. After the address sequence is completed, the next operation must be a write cycle. The lower data byte contains the write-protect settings. This value will not be written to the memory array, so the address is a don't-care. Rather it will be held pending the next cycle, which must be a write of the data complement to the protection settings. If the complement is correct, the write-protect settings will be adjusted. Otherwise, the process is aborted and the address sequence starts over. The data value written after the correct six addresses will not be entered into the memory.

The protection data byte consists of eight bits, each associated with the write-protect state of a sector. The data byte must be driven to the lower eight bits of the data bus, DQ<sub>7</sub>–DQ<sub>0</sub>. Setting a bit to '1' write-protects the corresponding sector; a '0' enables writes for that sector. The following table shows the write-protect sectors with the corresponding bit that controls the write-protect setting.

**Table 1. Write Protect Sectors - 32K × 16 Blocks**

Sectors	Blocks
Sector 7	3FFFFh–38000h
Sector 6	37FFFh–30000h
Sector 5	2FFFFh–28000h
Sector 4	27FFFh–20000h
Sector 3	1FFFFh–18000h
Sector 2	17FFFh–10000h
Sector 1	0FFFFh–08000h
Sector 0	07FFFh–00000h

The write-protect address sequence follows:

1. Read address 24555h
2. Read address 3AAAAh
3. Read address 02333h
4. Read address 1CCCCh
5. Read address 000FFh
6. Read address 3EF00h
7. Write address 3AAAAh
8. Write address 1CCCCh
9. Write address 0FF00h
10. Read address 00000h

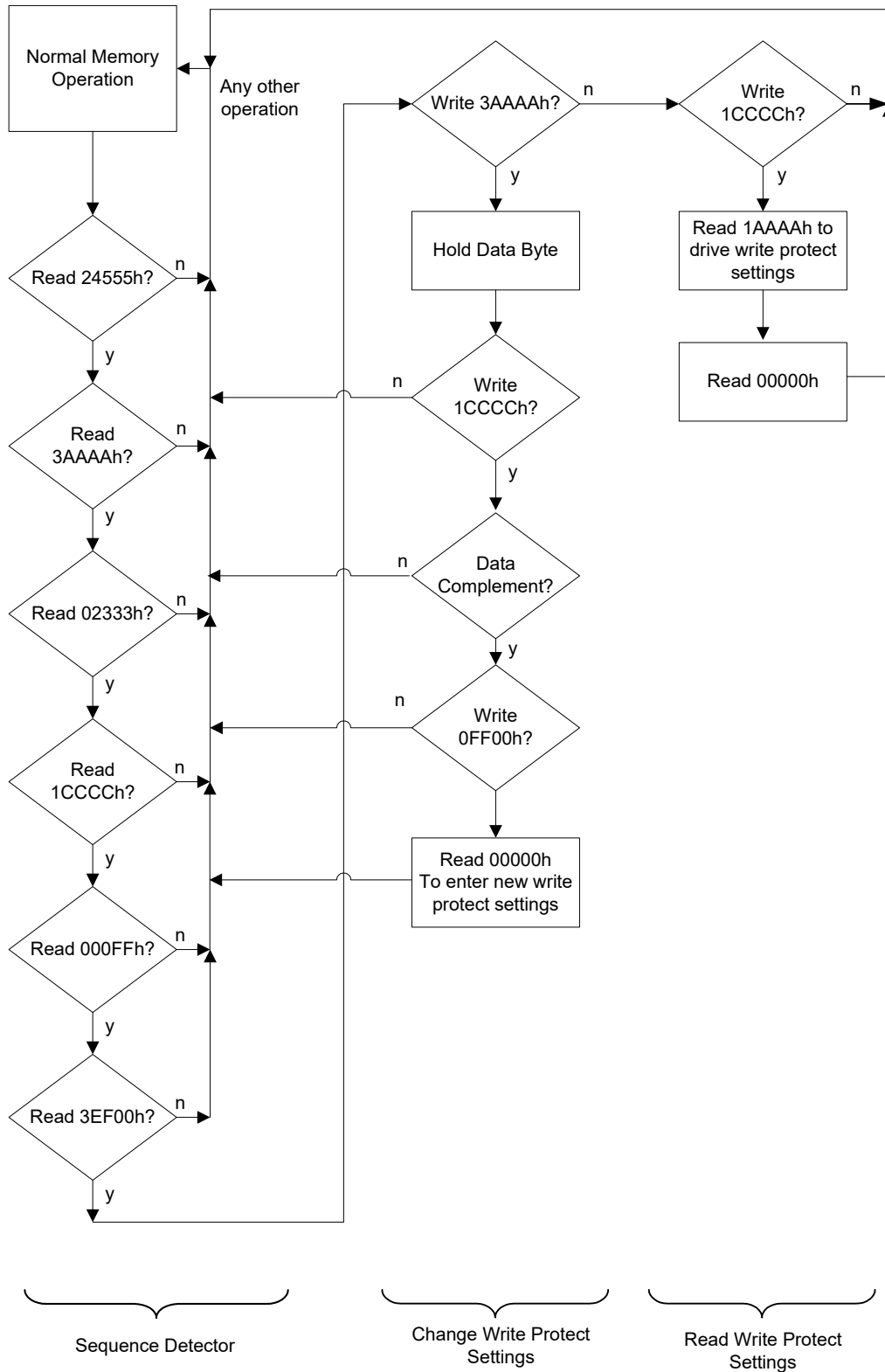
**Note** If  $\overline{CE}$  is LOW entering the sequence, then an address of 00000h must precede 24555h.

The address sequence provides a secure way of modifying the protection. The write-protect sequence has a one in  $3 \times 10^{32}$  chance of randomly accessing exactly the first six addresses. The odds are further reduced by requiring three more write cycles, one that requires an exact inversion of the data byte. [Figure 2 on page 6](#) shows a flow chart of the entire write-protect operation. The write-protect settings are nonvolatile. The factory default: all blocks are unprotected.

For example, the following sequence write-protects addresses from 18000h to 27FFFh (sectors 3 and 4):

	Address	Data
Read	24555h	–
Read	3AAAAh	–
Read	02333h	–
Read	1CCCCh	–
Read	000FFh	–
Read	3EF00h	–
Write	3AAAAh	18h; bits 3 and 4 = 1
Write	1CCCCh	E7h; complement of 18h
Write	0FF00h	Don't care
Read	00000h	

**Figure 2. Write-Protect State Machine**



Software Write-Protect Timing

Figure 3. Sequence to Set Write-Protect Blocks [1]

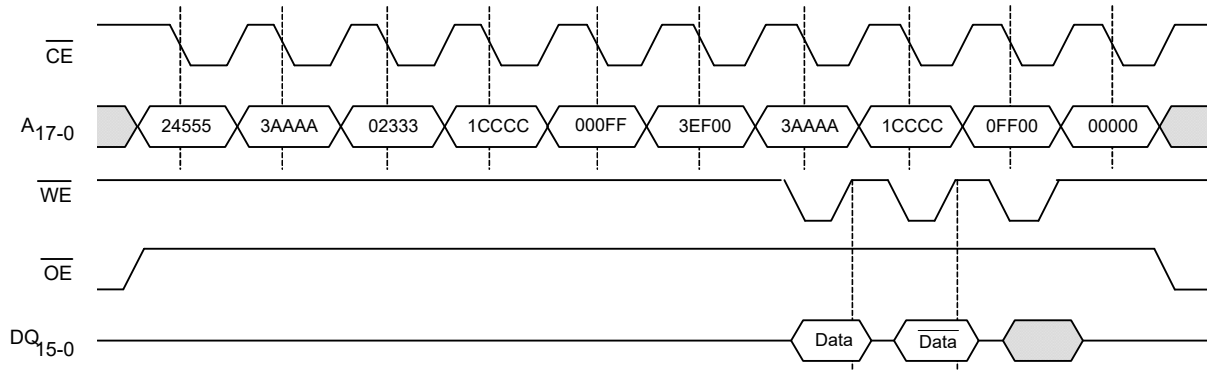
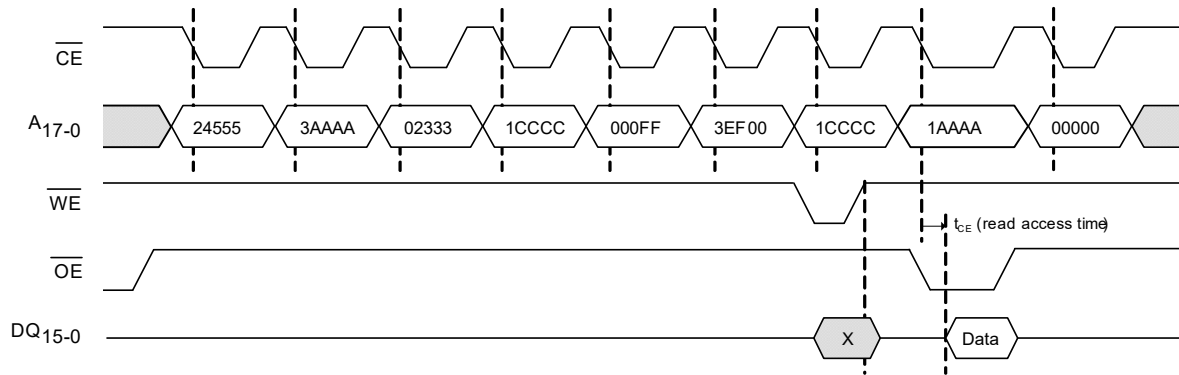


Figure 4. Sequence to Read Write-Protect Settings [1]



Note

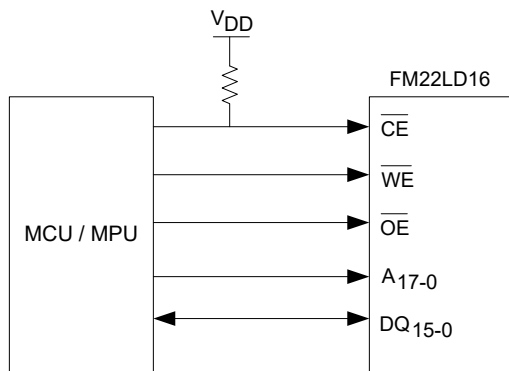
1. This sequence requires  $t_{AS} \geq 10$  ns and address must be stable while  $\overline{CE}$  is LOW.

### SRAM Drop-In Replacement

The FM22LD16 is designed to be a drop-in replacement for standard asynchronous SRAMs. The device does not require  $\overline{CE}$  to toggle for each new address.  $\overline{CE}$  may remain LOW indefinitely. While  $\overline{CE}$  is LOW, the device automatically detects address changes and a new access begins. This functionality allows  $\overline{CE}$  to be grounded as you might with an SRAM. It also allows page mode operation at speeds up to 40 MHz.

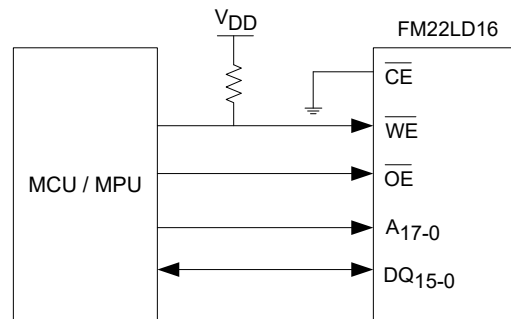
Figure 5 shows a pull-up resistor on  $\overline{CE}$ , which will keep the pin HIGH during power cycles, assuming the MCU / MPU pin tristates during the reset condition. The pull-up resistor value should be chosen to ensure the  $\overline{CE}$  pin tracks  $V_{DD}$  to a high enough value, so that the current drawn when  $\overline{CE}$  is LOW is not an issue. A 10-k $\Omega$  resistor draws 330  $\mu$ A when  $\overline{CE}$  is LOW and  $V_{DD} = 3.3$  V.

Figure 5. Use of Pull-up Resistor on  $\overline{CE}$



Note that if  $\overline{CE}$  is tied to ground, the user must be sure  $\overline{WE}$  is not LOW at power-up or power-down events. If  $\overline{CE}$  and  $\overline{WE}$  are both LOW during power cycles, data will be corrupted. Figure 6 shows a pull-up resistor on  $\overline{WE}$ , which will keep the pin HIGH during power cycles, assuming the MCU / MPU pin tristates during the reset condition. The pull-up resistor value should be chosen to ensure the  $\overline{WE}$  pin tracks  $V_{DD}$  to a high enough value, so that the current drawn when  $\overline{WE}$  is LOW is not an issue. A 10-k $\Omega$  resistor draws 330  $\mu$ A when  $\overline{WE}$  is LOW and  $V_{DD} = 3.3$  V.

Figure 6. Use of Pull-up Resistor on  $\overline{WE}$

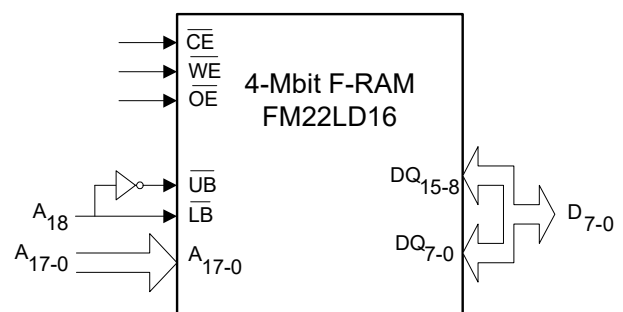


**Note** If  $\overline{CE}$  is tied to ground, the user gives up the ability to perform the software write-protect sequence.

For applications that require the lowest power consumption, the  $\overline{CE}$  signal should be active (LOW) only during memory accesses. The FM22LD16 draws supply current while  $\overline{CE}$  is LOW, even if addresses and control signals are static. While  $\overline{CE}$  is HIGH, the device draws no more than the maximum standby current,  $I_{SB}$ .  $\overline{CE}$  toggling LOW on every address access is perfectly acceptable in FM22LD16.

The  $\overline{UB}$  and  $\overline{LB}$  byte select pins are active for both read and write cycles. They may be used to allow the device to be wired as a 512K  $\times$  8 memory. The upper and lower data bytes can be tied together and controlled with the byte selects. Individual byte enables or the next higher address line  $A_{18}$  may be available from the system processor.

Figure 7. FM22LD16 Wired as 512K  $\times$  8





## Maximum Ratings

Exceeding maximum ratings may shorten the useful life of the device. These user guidelines are not tested.

Storage temperature .....	-65 °C to +125 °C
Maximum accumulated storage time	
At 125 °C ambient temperature .....	1000 h
At 85 °C ambient temperature .....	10 Years
Ambient temperature	
with power applied .....	-55 °C to +125 °C
Supply voltage on $V_{DD}$ relative to $V_{SS}$ .....	-1.0 V to + 4.5 V
Voltage applied to outputs	
in High Z state .....	-0.5 V to $V_{DD} + 0.5$ V
Input voltage .....	-1.0 V to + 4.5 V and $V_{IN} < V_{DD} + 1.0$ V
Transient voltage (< 20 ns)	
on any pin to ground potential .....	-2.0 V to $V_{CC} + 2.0$ V

Package power dissipation capability	
( $T_A = 25$ °C) .....	1.0 W
Surface mount Pb soldering temperature	
(3 seconds) .....	+260 °C
DC output current	
(1 output at a time, 1s duration) .....	15 mA
Static discharge voltage	
Human Body Model (JEDEC Std JESD22-A114-D) .....	2.5 kV
Charged Device Model (JEDEC Std JESD22-C101-C) ...	1.5 kV
Machine Model (JEDEC Std JESD22-A115-A) .....	150 V
Latch-up current .....	> 100 mA

## Operating Range

Range	Ambient Temperature ( $T_A$ )	$V_{DD}$
Industrial	-40 °C to +85 °C	2.7 V to 3.6 V

## DC Electrical Characteristics

Over the [Operating Range](#)

Parameter	Description	Test Conditions	Min	Typ <sup>[2]</sup>	Max	Unit	
$V_{DD}$	Power supply voltage		2.7	3.3	3.6	V	
$I_{DD}$	$V_{DD}$ supply current	$V_{DD} = 3.6$ V, $\overline{CE}$ cycling at min. cycle time. All inputs toggling at CMOS levels (0.2 V or $V_{DD} - 0.2$ V), all DQ pins unloaded.	-	8	12	mA	
$I_{SB}$	Standby current	$V_{DD} = 3.6$ V, $\overline{CE}$ at $V_{DD}$ , All other pins are static and at CMOS levels (0.2 V or $V_{DD} - 0.2$ V)	$T_A = 25$ °C	-	90	150	$\mu$ A
			$T_A = 85$ °C	-	-	270	$\mu$ A
$I_{LI}$	Input leakage current	$V_{IN}$ between $V_{DD}$ and $V_{SS}$	-	-	$\pm 1$	$\mu$ A	
$I_{LO}$	Output leakage current	$V_{OUT}$ between $V_{DD}$ and $V_{SS}$	-	-	$\pm 1$	$\mu$ A	
$V_{IH}$	Input HIGH voltage		2.2	-	$V_{DD} + 0.3$	V	
$V_{IL}$	Input LOW voltage		-0.3	-	0.6	V	
$V_{OH1}$	Output HIGH voltage	$I_{OH} = -1.0$ mA	2.4	-	-	V	
$V_{OH2}$	Output HIGH voltage	$I_{OH} = -100$ $\mu$ A	$V_{DD} - 0.2$	-	-	V	
$V_{OL1}$	Output LOW voltage	$I_{OL} = 2.1$ mA	-	-	0.4	V	
$V_{OL2}$	Output LOW voltage	$I_{OL} = 100$ $\mu$ A	-	-	0.2	V	

### Note

2. Typical values are at 25 °C,  $V_{DD} = V_{DD}$  (typ). Not 100% tested.

### Data Retention and Endurance

Parameter	Description	Test condition	Min	Max	Unit
T <sub>DR</sub>	Data retention	T <sub>A</sub> = 85 °C	10	–	Years
		T <sub>A</sub> = 75 °C	38	–	
		T <sub>A</sub> = 65 °C	151	–	
NV <sub>C</sub>	Endurance	Over operating temperature	10 <sup>14</sup>	–	Cycles

### Capacitance

Parameter	Description	Test Conditions	Max	Unit
C <sub>I/O</sub>	Input/Output capacitance (DQ)	T <sub>A</sub> = 25 °C, f = 1 MHz, V <sub>DD</sub> = V <sub>DD</sub> (Typ)	8	pF
C <sub>IN</sub>	Input capacitance		6	pF

### Thermal Resistance

Parameter	Description	Test Conditions	48-ball FBGA	Unit
Θ <sub>JA</sub>	Thermal resistance (junction to ambient)	Test conditions follow standard test methods and procedures for measuring thermal impedance, in accordance with EIA/JESD51.	41	°C/W
Θ <sub>JC</sub>	Thermal resistance (junction to case)		10	°C/W

### AC Test Conditions

Input pulse levels ..... 0 V to 3 V  
 Input rise and fall times (10%–90%) ..... ≤ 3 ns  
 Input and output timing reference levels ..... 1.5 V  
 Output load capacitance ..... 30 pF

## AC Switching Characteristics

Over the [Operating Range](#)

Parameters <sup>[3]</sup>		Description	Min	Max	Unit
Cypress Parameter	Alt Parameter				
<b>SRAM Read Cycle</b>					
$t_{CE}$	$t_{ACE}$	Chip enable access time	–	55	ns
$t_{RC}$	–	Read cycle time	110	–	ns
$t_{AA}$	–	Address access time	–	110	ns
$t_{OH}$	$t_{OHA}$	Output hold time	20	–	ns
$t_{AAP}$	–	Page mode address access time	–	25	ns
$t_{OHP}$	–	Page mode output hold time	5	–	ns
$t_{CA}$	–	Chip enable active time	55	–	ns
$t_{PC}$	–	Pre-charge time	55	–	ns
$t_{BA}$	$t_{BW}$	$\overline{UB}$ , $\overline{LB}$ access time	–	20	ns
$t_{AS}$	$t_{SA}$	Address setup time (to $\overline{CE}$ LOW)	0	–	ns
$t_{AH}$	$t_{HA}$	Address hold time ( $\overline{CE}$ Controlled)	55	–	ns
$t_{OE}$	$t_{DOE}$	Output enable access time	–	15	ns
$t_{HZ}^{[4, 5]}$	$t_{HZCE}$	Chip Enable to output HI-Z	–	10	ns
$t_{OHZ}^{[4, 5]}$	$t_{HZOE}$	Output enable HIGH to output HI-Z	–	10	ns
$t_{BHZ}^{[4, 5]}$	$t_{HZBE}$	$\overline{UB}$ , $\overline{LB}$ HIGHHIGH to output HI-Z	–	10	ns

### Notes

- Test conditions assume a signal transition time of 3 ns or less, timing reference levels of  $0.5 \times V_{DD}$ , input pulse levels of 0 to 3 V, output loading of the specified  $I_{OL}/I_{OH}$  and load capacitance shown in [AC Test Conditions on page 10](#).
- $t_{HZ}$ ,  $t_{OHZ}$  and  $t_{BHZ}$  are specified with a load capacitance of 5 pF. Transition is measured when the outputs enter a high impedance state.
- This parameter is characterized but not 100% tested.

**AC Switching Characteristics** (continued)

 Over the [Operating Range](#)

Parameters <sup>[3]</sup>		Description	Min	Max	Unit
Cypress Parameter	Alt Parameter				
<b>SRAM Write Cycle</b>					
$t_{WC}$	$t_{WC}$	Write cycle time	110	–	ns
$t_{CA}$	–	Chip enable active time	55	–	ns
$t_{CW}$	$t_{SCE}$	Chip enable to write enable HIGH	55	–	ns
$t_{PC}$	–	Pre-charge time	55	–	ns
$t_{PWC}$	–	Page mode write enable cycle time	25	–	ns
$t_{WP}$	$t_{PWE}$	Write enable pulse width	16	–	ns
$t_{AS}$	$t_{SA}$	Address setup time (to $\overline{CE}$ LOW)	0	–	ns
$t_{ASP}$	–	Page mode address setup time (to $\overline{WE}$ LOW)	8	–	ns
$t_{AHP}$	–	Page mode address hold time (to $\overline{WE}$ LOW)	15	–	ns
$t_{WLC}$	$t_{PWE}$	Write enable LOW to chip disabled	25	–	ns
$t_{BLC}$	$t_{BW}$	$\overline{UB}$ , $\overline{LB}$ LOW to chip disabled	25	–	ns
$t_{WLA}$	–	Write enable LOW to $A_{17-2}$ change	25	–	ns
$t_{AWH}$	–	$A_{17-2}$ change to write enable HIGH	110	–	ns
$t_{BS}$		$\overline{UB}$ , $\overline{LB}$ setup time (to $\overline{CE}$ LOW)	2	–	ns
$t_{BH}$		$\overline{UB}$ , $\overline{LB}$ hold time (to $\overline{CE}$ HIGH)	0	–	ns
$t_{DS}$	$t_{SD}$	Data input setup time	14	–	ns
$t_{DH}$	$t_{HD}$	Data input hold time	0	–	ns
$t_{WZ}^{[6, 7]}$	$t_{HZWE}$	Write enable LOW to output HI-Z	–	10	ns
$t_{WX}^{[7]}$	–	Write enable HIGH to output driven	10	–	ns
$t_{WS}^{[8]}$	–	Write enable to $\overline{CE}$ LOW setup time	0	–	ns
$t_{WH}^{[8]}$	–	Write enable to $\overline{CE}$ HIGH hold time	0	–	ns

**Notes**

6.  $t_{WZ}$  is specified with a load capacitance of 5 pF. Transition is measured when the outputs enter a high impedance state.
7. This parameter is characterized but not 100% tested.
8. The relationship between  $\overline{CE}$  and  $\overline{WE}$  determines if a  $\overline{CE}$ - or  $\overline{WE}$ -controlled write occurs. The parameters  $t_{WS}$  and  $t_{WH}$  are not tested.

Figure 8. Read Cycle Timing 1 ( $\overline{CE}$  LOW,  $\overline{OE}$  LOW)

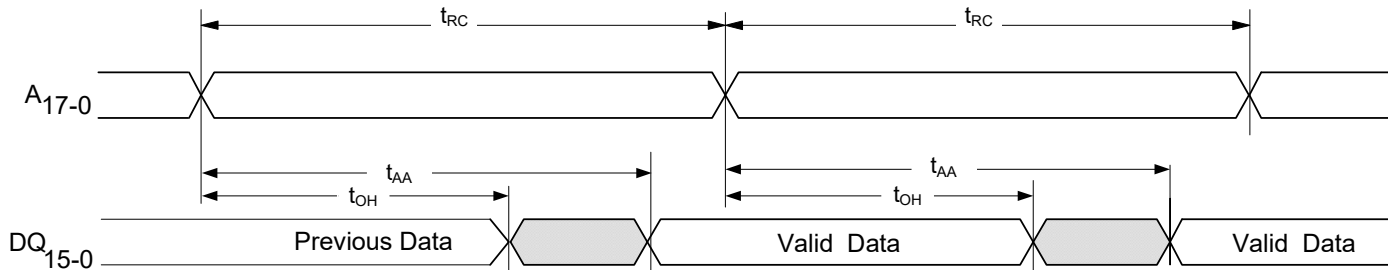


Figure 9. Read Cycle Timing 2 ( $\overline{CE}$  Controlled)

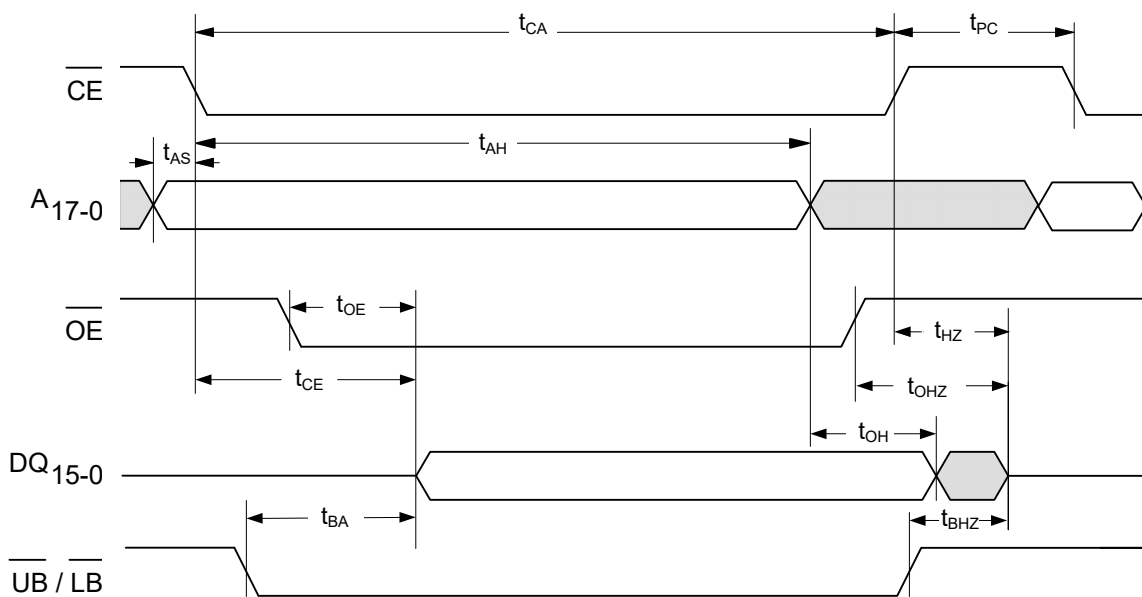
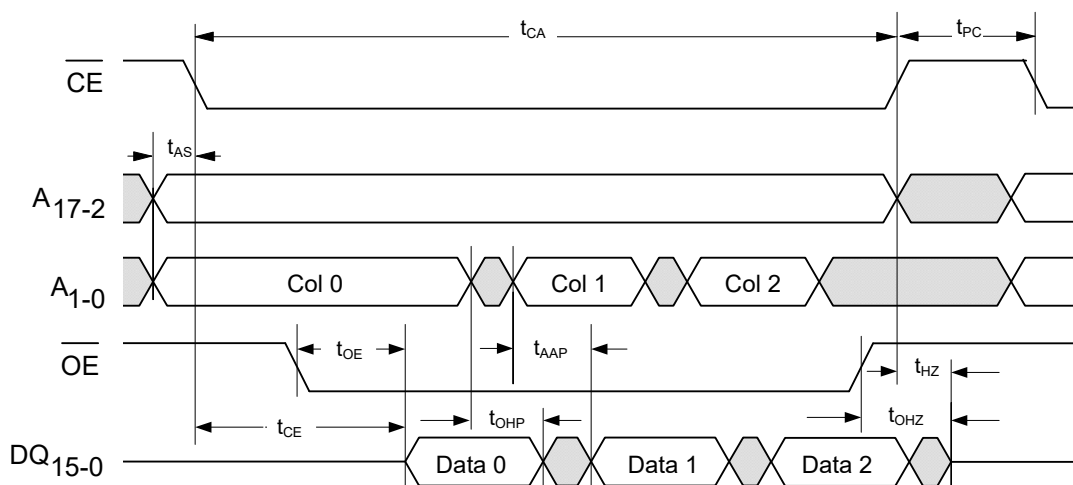


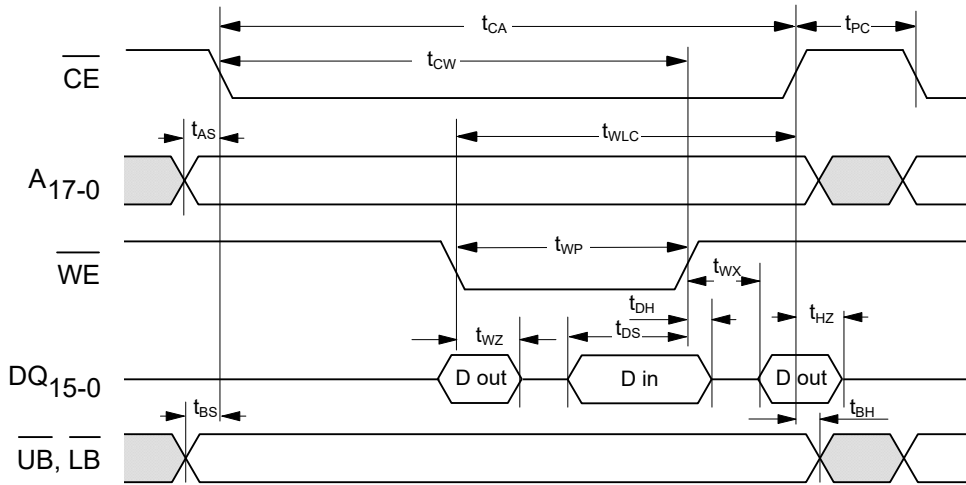
Figure 10. Page Mode Read Cycle Timing <sup>[9]</sup>



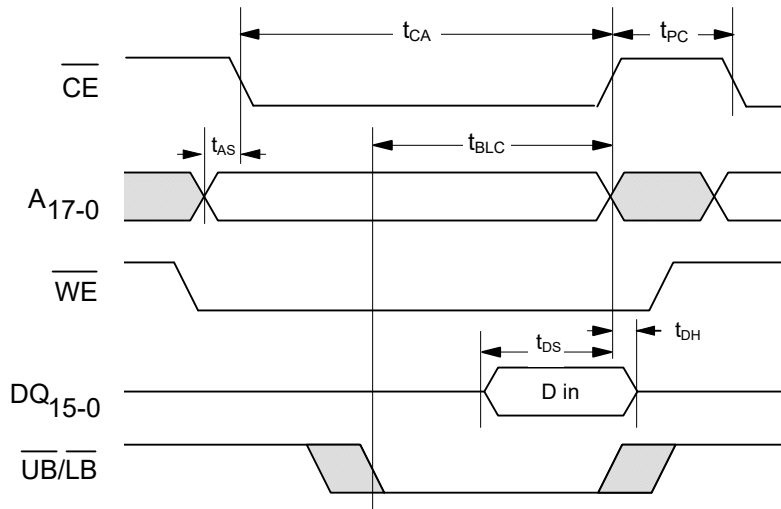
**Note**

9. Although sequential column addressing is shown, it is not required.

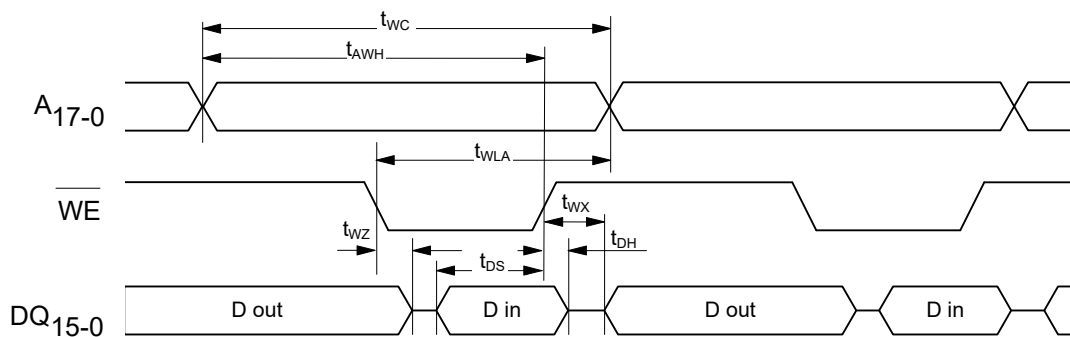
**Figure 11. Write Cycle Timing 1 ( $\overline{WE}$  Controlled) [10]**



**Figure 12. Write Cycle Timing 2 ( $\overline{CE}$  Controlled)**

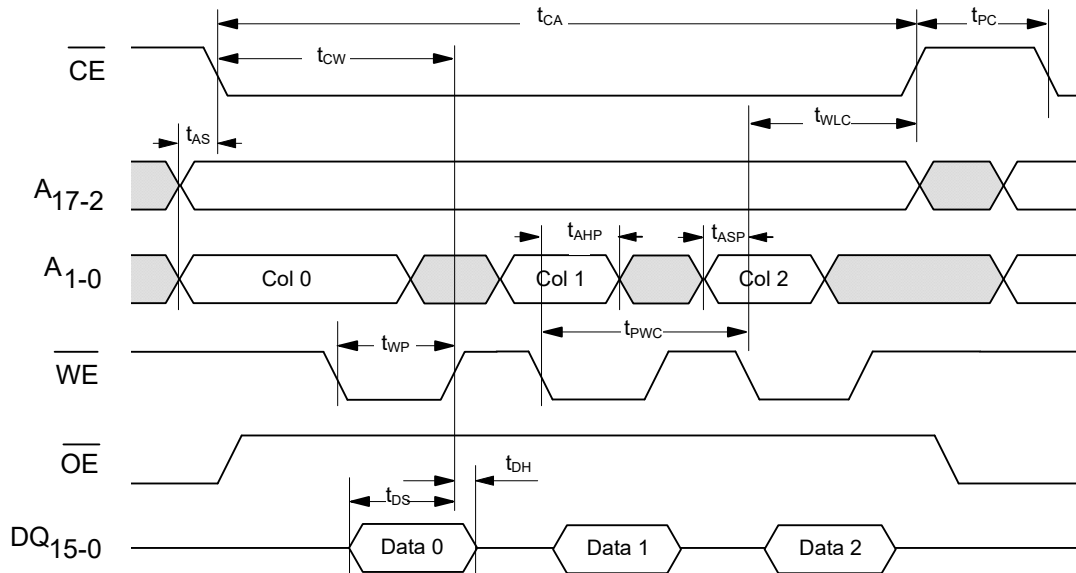


**Figure 13. Write Cycle Timing 3 ( $\overline{CE}$  LOW) [10]**



**Note**  
10.  $\overline{OE}$  (not shown) is LOW only to show the effect of  $\overline{WE}$  on DQ pins.

**Figure 14. Page Mode Write Cycle Timing**



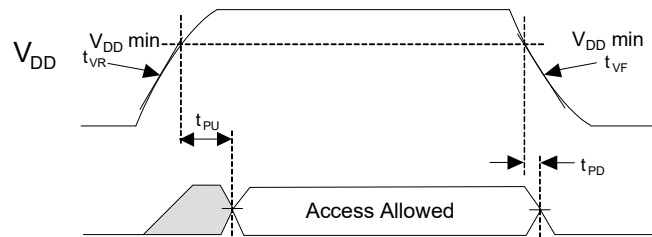
**Note**  
11.  $\overline{UB}$  and  $\overline{LB}$  to show byte enable and byte masking cases.

## Power Cycle and Sleep Mode Timing

Over the [Operating Range](#)

Parameter	Description	Min	Max	Unit
$t_{PU}$	Power-up (after $V_{DD}$ min. is reached) to first access time	450	–	$\mu\text{s}$
$t_{PD}$	Last write ( $\overline{WE}$ HIGH) to power down time	0	–	$\mu\text{s}$
$t_{VR}^{[12, 13]}$	$V_{DD}$ power-up ramp rate	50	–	$\mu\text{s/V}$
$t_{VF}^{[12, 13]}$	$V_{DD}$ power-down ramp rate	100	–	$\mu\text{s/V}$

**Figure 15. Power Cycle and Sleep Mode Timing**



### Notes

12. Slope measured at any point on the  $V_{DD}$  waveform.

13. Cypress cannot test or characterize all  $V_{DD}$  power ramp profiles. The behavior of the internal circuits is difficult to predict when  $V_{DD}$  is below the level of a transistor threshold voltage. Cypress strongly recommends that  $V_{DD}$  power up faster than 100 ns through the range of 0.4 V to 1.0 V.



**Functional Truth Table**

$\overline{\text{CE}}$	$\overline{\text{WE}}$	$\text{A}_{17-2}$	$\text{A}_{1-0}$	Operation <sup>[14, 15]</sup>
H	X	X	X	Standby/Idle
↓ L	H H	V V	V V	Read
L	H	No Change	Change	Page Mode Read
L	H	Change	V	Random Read
↓ L	L L	V V	V V	$\overline{\text{CE}}$ -Controlled Write <sup>[15]</sup>
L	↓	V	V	$\overline{\text{WE}}$ -Controlled Write <sup>[15, 16]</sup>
L	↓	No Change	V	Page Mode Write <sup>[17]</sup>
↑ L	X X	X X	X X	Starts pre-charge

**Notes**

14. H = Logic HIGH, L = Logic LOW, V = Valid Data, X = Don't Care, ↓ = toggle LOW, ↑ = toggle HIGH.

15. For write cycles, data-in is latched on the rising edge of  $\overline{\text{CE}}$  or  $\overline{\text{WE}}$ , whichever comes first.

16.  $\overline{\text{WE}}$ -controlled write cycle begins as a Read cycle and then  $\text{A}_{17-2}$  is latched.

17. Addresses  $\text{A}_{1-0}$  must remain stable for at least 10 ns during page mode operation.

18. The UB and LB pins may be grounded if 1) the system does not perform byte writes and 2) the device is not configured as a 512K x 8.

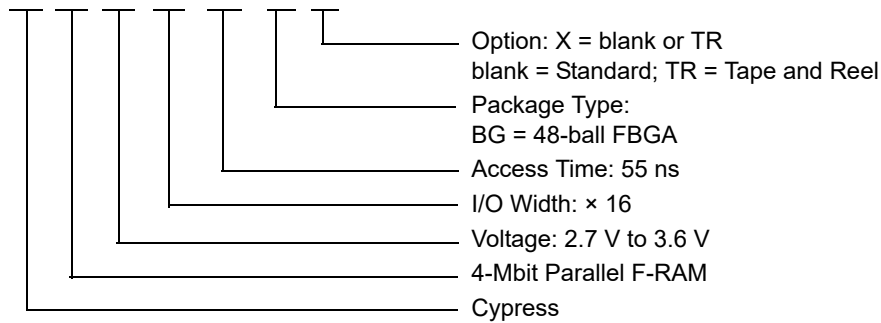
**Ordering Information**

Access Time (ns)	Ordering Code	Package Diagram	Package Type	Operating Range
55	FM22LD16-55-BG	001-91158	48-ball FBGA	Industrial
	FM22LD16-55-BGTR			

All the above parts are Pb-free.

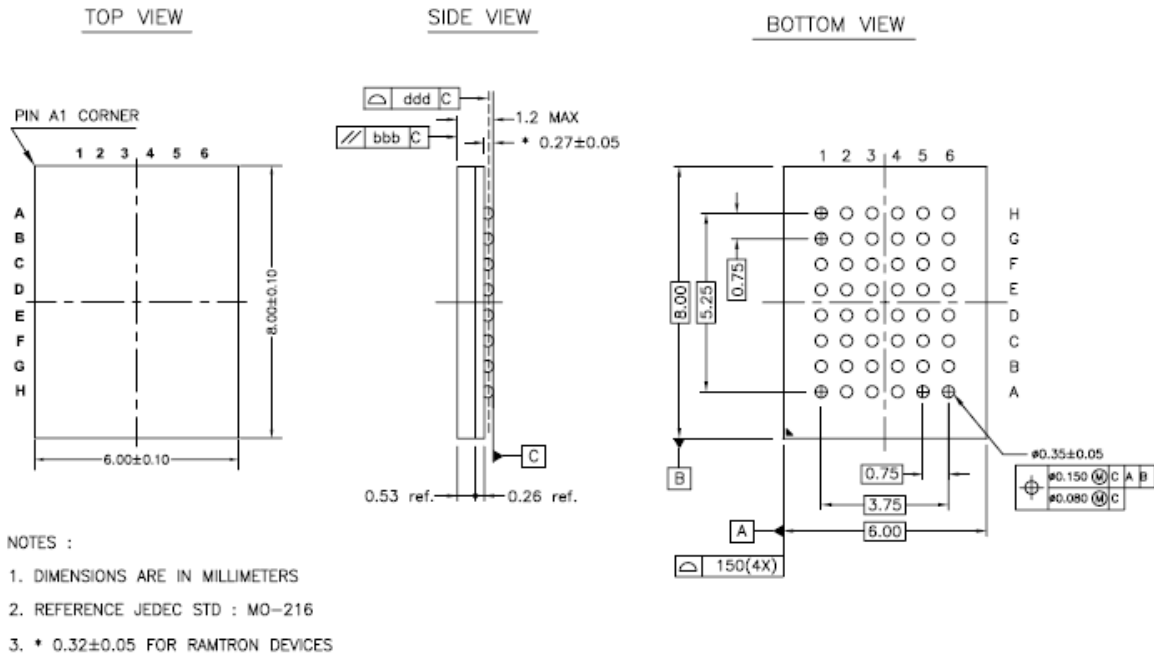
**Ordering Code Definitions**

FM 22 LD 16 - 55 - BG X



Package Diagram

Figure 16. 48-ball FBGA (6 × 8 × 1.2 mm) Package Outline, 001-91158



001-91158 \*\*

## Acronyms

Acronym	Description
CPU	Central Processing Unit
CMOS	Complementary Metal Oxide Semiconductor
EIA	Electronic Industries Alliance
F-RAM	Ferroelectric Random Access Memory
I/O	Input/Output
MCU	Microcontroller Unit
MPU	Microprocessor Unit
RoHS	Restriction of Hazardous Substances
R/W	Read and Write
SRAM	Static Random Access Memory
TSOP	Thin Small Outline Package

## Document Conventions

### Units of Measure

Symbol	Unit of Measure
°C	degree Celsius
Hz	hertz
kHz	kilohertz
kΩ	kilohm
MHz	megahertz
μA	microampere
μF	microfarad
μs	microsecond
mA	milliampere
ms	millisecond
MΩ	megaohm
ns	nanosecond
Ω	ohm
%	percent
pF	picofarad
V	volt
W	watt

**Document History Page**

Document Title: FM22LD16, 4-Mbit (256K × 16) F-RAM Document Number: 001-86190			
Rev.	ECN No.	Submission Date	Description of Change
**	3912933	02/25/2013	New spec.
*A	4191807	11/14/2013	Added watermark "Not recommended for new designs" across the document.
*B	4274811	03/11/2014	Removed watermark "Not recommended for new designs" across the document. Updated <a href="#">Maximum Ratings</a> : Added "Maximum Junction Temperature" and its corresponding details. Added "DC voltage applied to outputs in High-Z state" and its corresponding details. Added "Transient voltage (< 20 ns) on any pin to ground potential" and its corresponding details. Added "Package power dissipation capability (T <sub>A</sub> = 25 °C)" and its corresponding details. Added "DC output current (1 output at a time, 1s duration)" and its corresponding details. Added "Latch-up Current" and its corresponding details. Removed "Package Moisture Sensitivity Level" and its corresponding details. Updated <a href="#">Data Retention and Endurance</a> : Removed existing details of T <sub>DR</sub> parameter. Added details of T <sub>DR</sub> parameter corresponding to "T <sub>A</sub> = 85 °C", "T <sub>A</sub> = 75 °C" and "T <sub>A</sub> = 65 °C". Added NV <sub>C</sub> parameter and its corresponding details. Added <a href="#">Thermal Resistance</a> . Updated <a href="#">Package Diagram</a> : Removed Package Marking Scheme (top mark). Removed "Ramtron Revision History". Updated to Cypress template. Completing Sunset Review.
*C	4566147	11/10/2014	Updated <a href="#">Functional Description</a> : Added "For a complete list of related documentation, click <a href="#">here</a> ." at the end.
*D	4879990	08/11/2015	Updated <a href="#">Maximum Ratings</a> : Removed "Maximum junction temperature" and its corresponding details. Added "Maximum accumulated storage time" and its corresponding details. Added "Ambient temperature with power applied" and its corresponding details. Updated to new template.
*E	5110110	01/27/2016	Updated <a href="#">Maximum Ratings</a> : Changed value of "Latch-up current" from "> 140 mA" to "> 100 mA". Completing Sunset Review.
*F	5962083	11/09/2017	Updated Cypress Logo and Copyright.
*G	6390500	11/21/2018	Updated <a href="#">Maximum Ratings</a> : Replaced "-55 °C to +125 °C" with "-65 °C to +125 °C" in ratings corresponding to "Storage temperature". Updated to new template.
*H	6735005	11/20/2019	Updated <a href="#">Device Operation</a> : Updated <a href="#">Software Write-Protect Timing</a> : Updated <a href="#">Figure 4</a> . Updated to new template.

## Sales, Solutions, and Legal Information

### Worldwide Sales and Design Support

Cypress maintains a worldwide network of offices, solution centers, manufacturer's representatives, and distributors. To find the office closest to you, visit us at [Cypress Locations](#).

#### Products

Arm® Cortex® Microcontrollers	<a href="http://cypress.com/arm">cypress.com/arm</a>
Automotive	<a href="http://cypress.com/automotive">cypress.com/automotive</a>
Clocks & Buffers	<a href="http://cypress.com/clocks">cypress.com/clocks</a>
Interface	<a href="http://cypress.com/interface">cypress.com/interface</a>
Internet of Things	<a href="http://cypress.com/iot">cypress.com/iot</a>
Memory	<a href="http://cypress.com/memory">cypress.com/memory</a>
Microcontrollers	<a href="http://cypress.com/mcu">cypress.com/mcu</a>
PSoC	<a href="http://cypress.com/psoc">cypress.com/psoc</a>
Power Management ICs	<a href="http://cypress.com/pmic">cypress.com/pmic</a>
Touch Sensing	<a href="http://cypress.com/touch">cypress.com/touch</a>
USB Controllers	<a href="http://cypress.com/usb">cypress.com/usb</a>
Wireless Connectivity	<a href="http://cypress.com/wireless">cypress.com/wireless</a>

#### PSoC® Solutions

[PSoC 1](#) | [PSoC 3](#) | [PSoC 4](#) | [PSoC 5LP](#) | [PSoC 6 MCU](#)

#### Cypress Developer Community

[Community](#) | [Projects](#) | [Video](#) | [Blogs](#) | [Training](#) | [Components](#)

#### Technical Support

[cypress.com/support](http://cypress.com/support)

© Cypress Semiconductor Corporation, 2013–2019. This document is the property of Cypress Semiconductor Corporation and its subsidiaries ("Cypress"). This document, including any software or firmware included or referenced in this document ("Software"), is owned by Cypress under the intellectual property laws and treaties of the United States and other countries worldwide. Cypress reserves all rights under such laws and treaties and does not, except as specifically stated in this paragraph, grant any license under its patents, copyrights, trademarks, or other intellectual property rights. If the Software is not accompanied by a license agreement and you do not otherwise have a written agreement with Cypress governing the use of the Software, then Cypress hereby grants you a personal, non-exclusive, nontransferable license (without the right to sublicense) (1) under its copyright rights in the Software (a) for Software provided in source code form, to modify and reproduce the Software solely for use with Cypress hardware products, only internally within your organization, and (b) to distribute the Software in binary code form externally to end users (either directly or indirectly through resellers and distributors), solely for use on Cypress hardware product units, and (2) under those claims of Cypress's patents that are infringed by the Software (as provided by Cypress, unmodified) to make, use, distribute, and import the Software solely for use with Cypress hardware products. Any other use, reproduction, modification, translation, or compilation of the Software is prohibited.

TO THE EXTENT PERMITTED BY APPLICABLE LAW, CYPRESS MAKES NO WARRANTY OF ANY KIND, EXPRESS OR IMPLIED, WITH REGARD TO THIS DOCUMENT OR ANY SOFTWARE OR ACCOMPANYING HARDWARE, INCLUDING, BUT NOT LIMITED TO, THE IMPLIED WARRANTIES OF MERCHANTABILITY AND FITNESS FOR A PARTICULAR PURPOSE. No computing device can be absolutely secure. Therefore, despite security measures implemented in Cypress hardware or software products, Cypress shall have no liability arising out of any security breach, such as unauthorized access to or use of a Cypress product. CYPRESS DOES NOT REPRESENT, WARRANT, OR GUARANTEE THAT CYPRESS PRODUCTS, OR SYSTEMS CREATED USING CYPRESS PRODUCTS, WILL BE FREE FROM CORRUPTION, ATTACK, VIRUSES, INTERFERENCE, HACKING, DATA LOSS OR THEFT, OR OTHER SECURITY INTRUSION (collectively, "Security Breach"). Cypress disclaims any liability relating to any Security Breach, and you shall and hereby do release Cypress from any claim, damage, or other liability arising from any Security Breach. In addition, the products described in these materials may contain design defects or errors known as errata which may cause the product to deviate from published specifications. To the extent permitted by applicable law, Cypress reserves the right to make changes to this document without further notice. Cypress does not assume any liability arising out of the application or use of any product or circuit described in this document. Any information provided in this document, including any sample design information or programming code, is provided only for reference purposes. It is the responsibility of the user of this document to properly design, program, and test the functionality and safety of any application made of this information and any resulting product. "High-Risk Device" means any device or system whose failure could cause personal injury, death, or property damage. Examples of High-Risk Devices are weapons, nuclear installations, surgical implants, and other medical devices. "Critical Component" means any component of a High-Risk Device whose failure to perform can be reasonably expected to cause, directly or indirectly, the failure of the High-Risk Device, or to affect its safety or effectiveness. Cypress is not liable, in whole or in part, and you shall and hereby do release Cypress from any claim, damage, or other liability arising from any use of a Cypress product as a Critical Component in a High-Risk Device. You shall indemnify and hold Cypress, its directors, officers, employees, agents, affiliates, distributors, and assigns harmless from and against all claims, costs, damages, and expenses, arising out of any claim, including claims for product liability, personal injury or death, or property damage arising from any use of a Cypress product as a Critical Component in a High-Risk Device. Cypress products are not intended or authorized for use as a Critical Component in any High-Risk Device except to the limited extent that (i) Cypress's published data sheet for the product explicitly states Cypress has qualified the product for use in a specific High-Risk Device, or (ii) Cypress has given you advance written authorization to use the product as a Critical Component in the specific High-Risk Device and you have signed a separate indemnification agreement.

Cypress, the Cypress logo, Spansion, the Spansion logo, and combinations thereof, WICED, PSoC, CapSense, EZ-USB, F-RAM, and Traveo are trademarks or registered trademarks of Cypress in the United States and other countries. For a more complete list of Cypress trademarks, visit [cypress.com](http://cypress.com). Other names and brands may be claimed as property of their respective owners.

# Mouser Electronics

Authorized Distributor

Click to View Pricing, Inventory, Delivery & Lifecycle Information:

[Cypress Semiconductor:](#)

[FM22LD16-55-BGTR](#) [FM22LD16-55-BG](#)