

Absolute Maximum Ratings

Voltage on V_{DD} , Relative to Ground -0.3V to +4.0V
 Voltage on Any Other Pin, Relative to Ground -0.3V to +6.0V
 Operating Temperature Range..... -55°C to +125°C

Storage Temperature Range -55°C to +125°C
 Lead Temperature (soldering, 10s) +260°C

Stresses beyond those listed under "Absolute Maximum Ratings" may cause permanent damage to the device. These are stress ratings only, and functional operation of the device at these or any other conditions beyond those indicated in the operational sections of the specifications is not implied. Exposure to absolute maximum rating conditions for extended periods may affect device reliability.

DC Electrical Characteristics

($1.7V \leq V_{DD} \leq 3.7V$, $T_A = -55^\circ\text{C}$ to $+125^\circ\text{C}$, unless otherwise noted.)

PARAMETER	SYMBOL	CONDITIONS	MIN	TYP	MAX	UNITS
Supply Voltage	V_{DD}		1.7		3.7	V
Thermometer Error (Note 1)	T_{ERR}	0 to +50		±0.5		°C
		-25 to +100			±2.0	
		-55 to +125			±3.0	
Input Logic-High	V_{IH}	(Note 2)	$0.7 \times V_{DD}$		5.5	V
Input Logic-Low	V_{IL}	(Note 2)	-0.5		$0.3 \times V_{DD}$	V
SDA Output Logic Low Voltage (Note 2)	V_{OL1}	3mA sink current	0		0.4	V
	V_{OL2}	6mA sink current	0		0.6	
OS Saturation Voltage	V_{OL}	4mA sink current (Notes 1, 2)			0.8	V
Input Current Each I/O Pin		$0.4 < V_{I/O} < 0.9 \times V_{DD}$	-10		+10	µA
I/O Capacitance	$C_{I/O}$				10	pF
Standby Current	I_{DD1}	(Notes 3, 4)			2	µA
Active Current (Notes 3, 4)	I_{DD}	Active temp conversions			1000	µA
		Communication only			100	

AC Electrical Characteristics

($1.7V \leq V_{DD} \leq 3.7V$, $T_A = -55^\circ\text{C}$ to $+125^\circ\text{C}$, unless otherwise noted.)

PARAMETER	SYMBOL	CONDITIONS	MIN	TYP	MAX	UNITS
Resolution			9		12	Bits
Temperature Conversion Time	t_{CONVT}	9-bit conversions			25	ms
		10-bit conversions			50	
		11-bit conversions			100	
		12-bit conversions			200	
SCL Frequency	f_{SCL}				400	kHz
Bus Free Time Between a STOP and START Condition	t_{BUF}	(Note 5)	1.3			µs
START and Repeated START Hold Time from Falling SCL	$t_{HD:STA}$	(Notes 5, 6)	600			ns

AC Electrical Characteristics (continued)

($1.7V \leq V_{DD} \leq 3.7V$, $T_A = -55^\circ\text{C}$ to $+125^\circ\text{C}$, unless otherwise noted.)

PARAMETER	SYMBOL	CONDITIONS	MIN	TYP	MAX	UNITS
Low Period of SCL	t_{LOW}	(Note 5)	1.3			μs
High Period of SCL	t_{HIGH}	(Note 5)	0.6			μs
Repeated START Condition Setup Time to Rising SCL	$t_{SU:STA}$	(Note 5)	600			ns
Data-Out Hold Time from Falling SCL	$t_{HD:DAT}$	(Notes 5, 7)	0		0.9	μs
Data-In Setup Time to Rising SCL	$t_{SU:DAT}$	(Note 5)	100			ns
Rise Time of SDA and SCL (Receive)	t_R	(Note 5)			1000	ns
Fall Time of SDA and SCL (Receive)	t_F	(Note 5)			300	ns
Spike Suppression Filter Time (Deglitch Filter)	t_{SS}		0		50	ns
STOP Setup Time to Rising SCL	$t_{SU:STO}$	(Note 5)	600			ns
Capacitive Load for Each Bus Line	C_B				400	pF
Input Capacitance	C_I			5		pF
Serial Interface Reset Time	$t_{TIMEOUT}$	SDA time low (Note 8)	75		325	ms

Note 1: Internal heating caused by OS loading causes the DS75LV to read approximately 0.5°C higher if OS is sinking the max rated current.

Note 2: All voltages are referenced to ground.

Note 3: I_{DD} specified with V_{DD} at 3.0V and SDA, SCL = 3.0V, 0°C to $+70^\circ\text{C}$.

Note 4: I_{DD} specified with OS pin open.

Note 5: See Figure 2 for timing diagram. All timing is referenced to $0.9 \times V_{DD}$ and $0.1 \times V_{DD}$.

Note 6: After this period, the first clock pulse is generated.

Note 7: The DS75LV provides an internal hold time of at least 75ns on the SDA signal to bridge the undefined region of SCL's falling edge.

Note 8: This timeout applies only when the DS75LV is holding SDA low. Other devices can hold SDA low indefinitely and the DS75LV does not reset.

Pin Description

PIN	NAME	FUNCTION
1	SDA	Data Input/Output. For 2-wire serial communication port. Open drain.
2	SCL	Clock Input. 2-wire serial communication port.
3	OS	Thermostat Output. Open drain.
4	GND	Ground
5	A2	Address Input
6	A1	Address Input
7	A0	Address Input
8	V _{DD}	Supply Voltage. +1.7V to +3.7V supply pin.

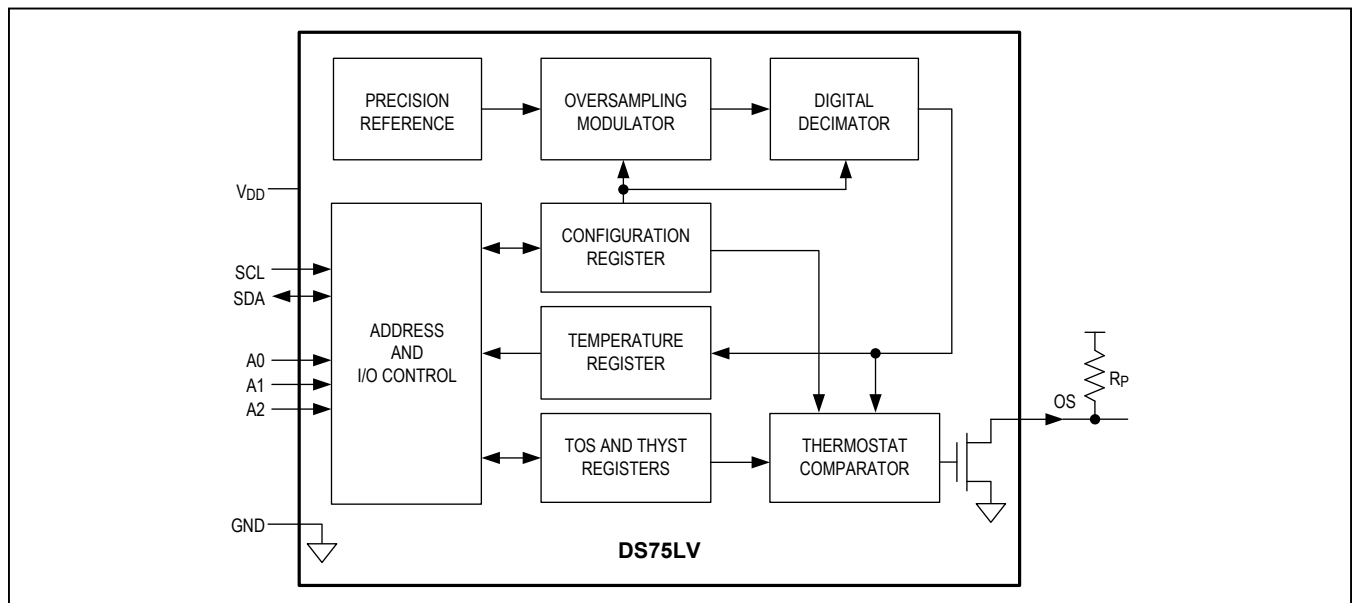

Figure 1. Block Diagram

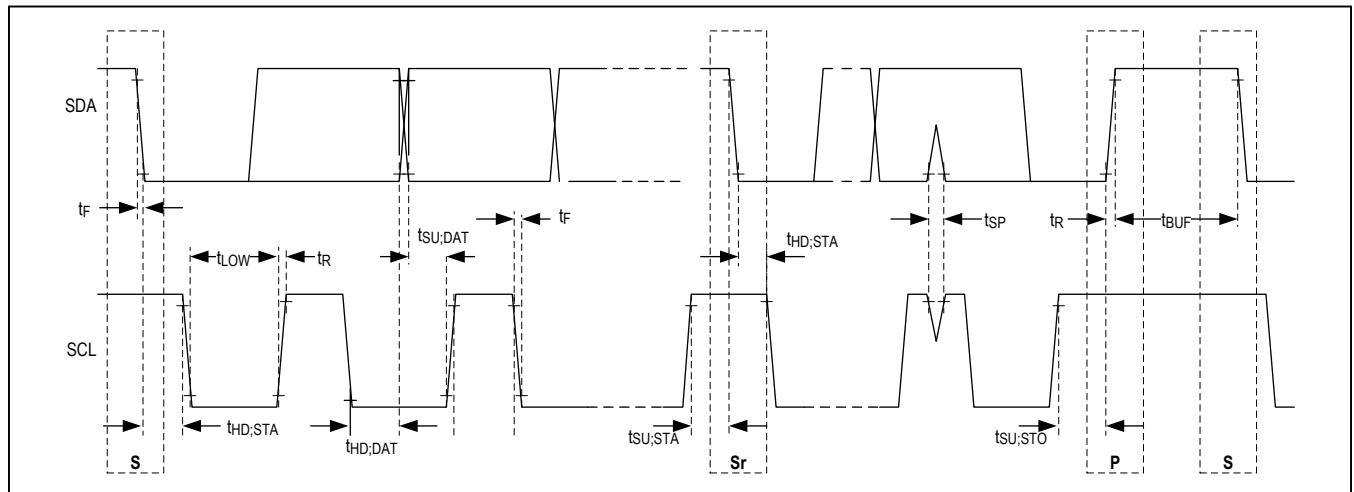

Figure 2. Timing Diagram

Detailed Description

Measuring Temperature

The DS75LV measures temperature using a bandgap temperature sensing architecture. An on-board delta-sigma analog-to-digital converter (ADC) converts the measured temperature to a digital value that is calibrated in degrees centigrade; for Fahrenheit applications a lookup table or conversion routine must be used. The DS75LV is factory-calibrated and requires no external components to measure temperature.

At power-up the DS75LV immediately begins converting temperature to a digital value. The resolution of the digital output data is user-configurable to 9, 10, 11, or 12 bits, corresponding to temperature increments of 0.5°C, 0.25°C, 0.125°C, and 0.0625°C, respectively, with 9-bit default resolution at power-up. The resolution is controlled via the R0 and R1 bits in the configuration register as explained in the [Configuration Register](#) section. Note that the conversion time doubles for each additional bit of resolution.

After each temperature measurement and analog-to-digital conversion, the DS75LV stores the temperature as a 16-bit two's complement number in the 2-byte temperature register (see [Figure 3](#)). The sign bit (S) indicates if the temperature is positive or negative: for positive numbers S = 0 and for negative numbers S = 1. The most recently converted digital measurement can be read from the temperature register at any time. Since temperature conversions are performed in the background, reading the temperature register does not affect the operation in progress.

Bits 3 through 0 of the temperature register are hardwired to 0. When the DS75LV is configured for 12-bit resolution, the 12 MSBs (bits 15 through 4) of the temperature register contain temperature data. For 11-bit resolution, the 11 MSBs (bits 15 through 5) of the temperature register contain data, and bit 4 reads out as 0. Likewise, for 10-bit resolution, the 10 MSBs (bits 15 through 6) contain data, and for 9-bit the 9 MSBs (bits 15 through 7) contain data, and all unused LSbs contain 0s. [Table 1](#) gives examples of 12-bit resolution digital output data and the corresponding temperatures.

Table 1. 12-Bit Resolution Temperature/ Data Relationship

TEMPERATURE (°C)	DIGITAL OUTPUT (BINARY)	DIGITAL OUTPUT (HEX)
+125	0111 1101 0000 0000	7D00h
+25.0625	0001 1001 0001 0000	1910h
+10.125	0000 1010 0010 0000	0A20h
+0.5	0000 0000 1000 0000	0080h
0	0000 0000 0000 0000	0000h
-0.5	1111 1111 1000 0000	FF80h
-10.125	1111 0101 1110 0000	F5E0h
-25.0625	1110 0110 1111 0000	E6F0h
-55	1100 1001 0000 0000	C900h

	bit 15	bit 14	bit 13	bit 12	bit 11	bit 10	bit 9	bit 8
MS Byte	S	2 ⁶	2 ⁵	2 ⁴	2 ³	2 ²	2 ¹	2 ⁰
	bit 7	bit 6	bit 5	bit 4	bit 3	bit 2	bit 1	bit 0
LS Byte	2 ⁻¹	2 ⁻²	2 ⁻³	2 ⁻⁴	0	0	0	0

Figure 3. Temperature, T_{OS}, and T_{HYST} Register Format

Shutdown Mode

For power-sensitive applications, the DS75LV offers a low-power shutdown mode. The SD bit in the configuration register controls shutdown mode. When SD is changed to 1, the conversion in progress is completed and the result stored in the temperature register after which the DS75LV goes into a low-power standby state. The OS output is cleared if the thermostat is operating in interrupt mode and OS remains unchanged in comparator mode. The 2-wire interface remains operational in shutdown mode, and writing a 0 to the SD bit returns the DS75LV to normal operation.

Thermostat

The DS75LV thermostat has two operating modes, comparator mode and interrupt mode, which activate and deactivate the open-drain thermostat output (OS) based on user-programmable trip-points (T_{OS} and T_{HYST}). The DS75LV powers up with the thermostat in comparator mode, active-low OS polarity, over-temperature trip-point (T_{OS}) register set to 80°C, and the hysteresis trip-point (T_{HYST}) register set to 75°C. If these power-up settings are compatible with the application, the DS75LV can be used as a standalone thermostat (i.e., no 2-wire communication required). If interrupt mode operation, active-high OS polarity or different T_{OS} and T_{HYST} values are desired, they must be programmed after power-up, so standalone operation is not possible.

In both operating modes, the user can program the thermostat fault tolerance, which sets how many consecutive temperature readings (1, 2, 4, or 6) must fall outside of the thermostat limits before the thermostat output is triggered. The fault tolerance is set by the F1 and F0 bits in the configuration register. At power-up the fault tolerance is set to 1.

The data format of the T_{OS} and T_{HYST} registers is identical to that of the temperature register (see [Figure 3](#)), i.e., a 2-byte two's complement representation of the trip-point temperature in degrees centigrade with bits 3 through 0 hardwired to 0. After every temperature conversion, the measurement is compared to the values stored in the T_{OS}

and T_{HYST} registers. The OS output is updated based on the result of the comparison and the operating mode of the IC. The number of T_{OS} and T_{HYST} bits used during the thermostat comparison is equal to the conversion resolution set by the R1 and R0 bits in the configuration register. For example, if the resolution is 9 bits, only the 9 MSBs of T_{OS} and T_{HYST} are used by the thermostat comparator.

The active state of the OS output can be changed via the POL bit in the configuration register. The power-up default is active low.

If the user does not wish to use the thermostat capabilities of the DS75LV, the OS output should be left floating. Note that if the thermostat is not used, the T_{OS} and T_{HYST} registers can be used for general storage of system data.

Comparator Mode: When the thermostat is in comparator mode, OS can be programmed to operate with any amount of hysteresis. The OS output becomes active when the measured temperature exceeds the T_{OS} value a consecutive number of times as defined by the F1 and F0 fault tolerance (FT) bits in the configuration register. OS then stays active until the first time the temperature falls below the value stored in T_{HYST} . Putting the device into shutdown mode does not clear OS in comparator mode. Thermostat comparator mode operation with FT = 2 is illustrated in [Figure 4](#).

Interrupt Mode: In interrupt mode, the OS output first becomes active when the measured temperature exceeds the T_{OS} value a consecutive number of times equal to the FT value in the configuration register. Once activated, OS can only be cleared by either putting the DS75LV into shutdown mode or by reading from any register (temperature, configuration, T_{OS} , or T_{HYST}) on the device. Once OS has been deactivated, it is only reactivated when the measured temperature falls below the T_{HYST} value a consecutive number of times equal to the FT value. Again, OS can only be cleared by putting the device into shutdown mode or reading any register. Thus, this interrupt/clear process is cyclical between T_{OS} and T_{HYST} events (i.e., T_{OS} , clear, T_{HYST} , clear, T_{OS} , clear, T_{HYST} , clear, etc.). Thermostat interrupt mode operation with FT = 2 is illustrated in [Figure 4](#).

Configuration Register

The configuration register allows the user to program various DS75LV options such as conversion resolution, thermostat fault tolerance, thermostat polarity, thermostat operating mode, and shutdown mode. The configuration

register is arranged as shown in [Figure 5](#) and detailed descriptions of each bit are provided in [Table 2](#). The user has read/write access to all bits in the configuration register except the MSb, which is a reserved read-only bit. The entire register is volatile, and thus powers up in its default state.

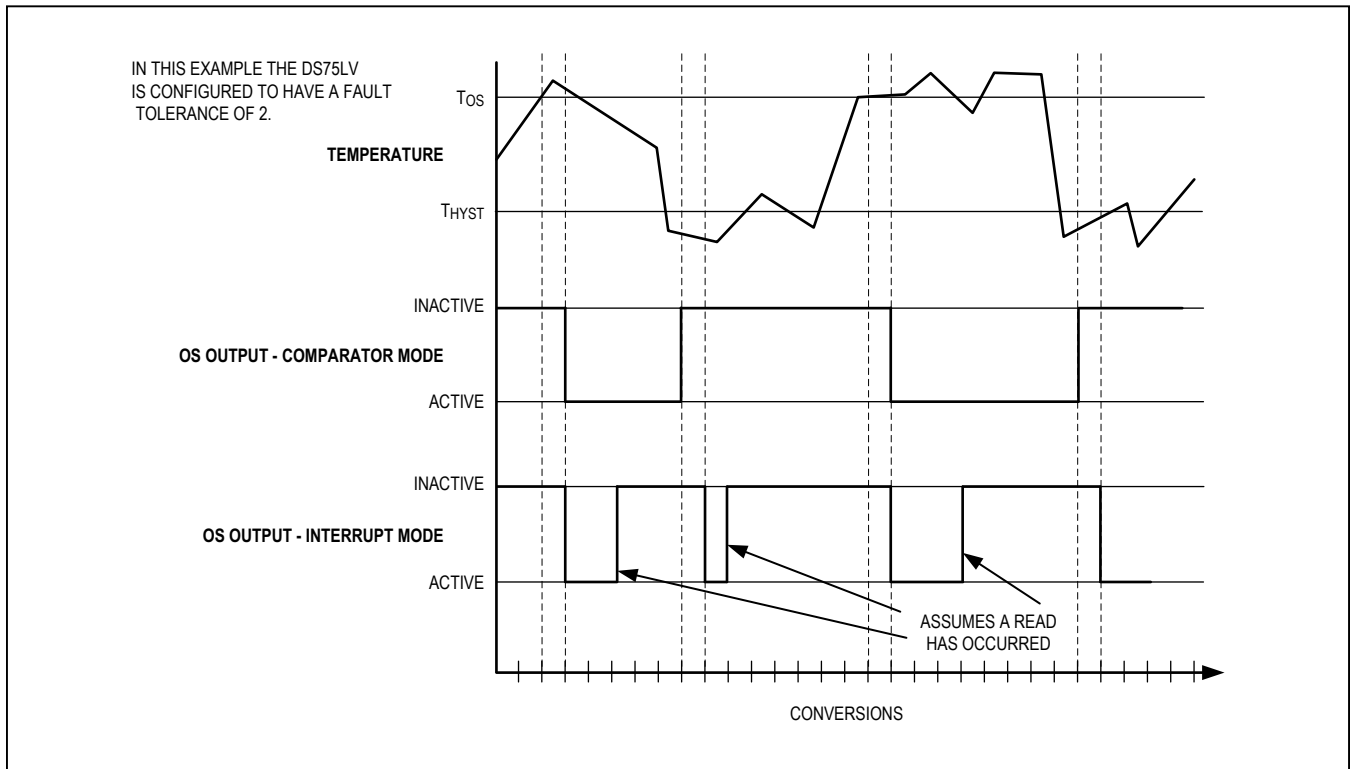

Figure 4. OS Output Operation Example

MSb	BIT 6	BIT 5	BIT 4	BIT 3	BIT 2	BIT 1	LSb
0	R1	R0	F1	F0	POL	TM	SD

Figure 5. Configuration Register

Table 2. Configuration Register Bit Descriptions

BIT NAME	FUNCTION
0 Reserved	Power-up state = 0 The master can write to this bit, but it will always read out as a 0.
R1 Conversion Resolution Bit 1	Power-up state = 0 Sets conversion resolution (see Table 3)
R0 Conversion Resolution Bit 0	Power-up state = 0 Sets conversion resolution (see Table 3)
F1 Thermostat Fault Tolerance Bit 1	Power-up state = 0 Sets the thermostat fault tolerance (see Table 4).
F0 Thermostat Fault Tolerance Bit 0	Power-up state = 0 Sets the thermostat fault tolerance (see Table 4).
POL Thermostat Output (OS) Polarity	Power-up state = 0 POL = 0 — OS is active low. POL = 1 — OS is active high.
TM Thermostat Operating Mode	Power-up state = 0 TM = 0 — Comparator mode TM = 1 — Interrupt mode See the <i>Thermostat</i> section for a detailed description of these modes.
SD Shutdown	Power-up state = 0 SD = 0 — Active conversion and thermostat operation. SD = 1 — Shutdown mode. See the <i>Shutdown Mode</i> section for a detailed description of this mode.

Table 3. Resolution Configuration

R1	R0	THERMOMETER RESOLUTION	MAX CONVERSION TIME (ms)
0	0	9-bit	25
0	1	10-bit	50
1	0	11-bit	100
1	1	12-bit	200

Table 5. Register Pointer Definition

REGISTER	P1	P0
Temperature	0	0
Configuration	0	1
T _{HYST}	1	0
T _{OS}	1	1

Table 4. Fault Tolerance Configuration

F1	F0	CONSECUTIVE OUT-OF-LIMITS CONVERSIONS TO TRIGGER OS
0	0	1
0	1	2
1	0	4
1	1	6

Register Pointer

The four DS75LV registers each have a unique 2-bit pointer designation, which is defined in [Table 5](#). When reading from or writing to the DS75LV, the user must “point” the DS75LV to the register that is to be accessed. When reading from the DS75LV, once the pointer is set, it remains pointed at the same register until it is changed. For example, if the user desires to perform consecutive reads from the temperature register, then the pointer only has to be set to the temperature register one time, after which all reads are automatically from the temperature register until the pointer value is changed. When writing to the DS75LV, the pointer value must be refreshed each time a write is performed, even if the same register is being written to twice in a row.

At power-up, the pointer defaults to the temperature register location. The temperature register can be read immediately without resetting the pointer.

Changes to the pointer setting are accomplished as described in the [2-Wire Serial Data Bus](#) section of this data sheet.

2-Wire Serial Data Bus

The DS75LV communicates over a standard bidirectional 2-wire serial data bus that consists of a serial clock (SCL) signal and serial data (SDA) signal. The device interfaces to the bus via the SCL input pin and open-drain SDA I/O pin. All communication is MSb first.

The following terminology is used to describe 2-wire communication:

Master Device: Microprocessor/microcontroller that controls the slave devices on the bus. The master device generates the SCL signal and START and STOP conditions.

Slave: All devices on the bus other than the master. The DS75LV always functions as a slave.

Bus Idle or Not Busy: Both SDA and SCL remain high. SDA is held high by a pullup resistor when the bus is idle, and SCL must either be forced high by the master (if the SCL output is push-pull) or pulled high by a pullup resistor (if the SCL output is open-drain).

Transmitter: A device (master or slave) that is sending data on the bus.

Receiver: A device (master or slave) that is receiving data from the bus.

START Condition: Signal generated by the master to indicate the beginning of a data transfer on the bus. The master generates a START condition by pulling SDA from high to low while SCL is high (see [Figure 6](#)). A “repeated” START is sometimes used at the end of a data transfer (instead of a STOP) to indicate that the master will perform another operation.

STOP Condition: Signal generated by the master to indicate the end of a data transfer on the bus. The master generates a STOP condition by transitioning SDA from low to high while SCL is high (see [Figure 6](#)). After the STOP is issued, the master releases the bus to its idle state.

Acknowledge (ACK): When a device (either master or slave) is acting as a receiver, it must generate an acknowledge (ACK) on the SDA line after receiving every byte of data. The receiving device performs an ACK by pulling the SDA line low for an entire SCL period (see [Figure 6](#)). During the ACK clock cycle, the transmitting device must release SDA. A variation on the ACK signal is the “not acknowledge” (NACK). When the master device is acting as a receiver, it uses a NACK instead of an ACK after the last data byte to indicate that it is finished receiving data. The master indicates a NACK by leaving the SDA line high during the ACK clock cycle.

Slave Address: Every slave device on the bus has a unique 7-bit address that allows the master to access that device. The DS75LV’s 7-bit bus address is 1 0 0 1 A2 A1 A0, where A2, A1, and A0 are user-selectable via the corresponding input pins. The three address pins allow up to eight DS75LVs to be multi-dropped on the same bus.

Address Byte: The control byte is transmitted by the master and consists of the 7-bit slave address plus a read/write (R/\bar{W}) bit (see [Figure 7](#)). If the master is going to read data from the slave device then $R/\bar{W} = 1$, and if the master is going to write data to the slave device then $R/\bar{W} = 0$.

Pointer Byte: The pointer byte is used by the master to tell the DS75LV which register is going to be accessed during communication. The six MSbs of the pointer byte (see [Figure 8](#)) are always 0 and the two LSbs correspond to the desired register as shown in [Table 5](#).

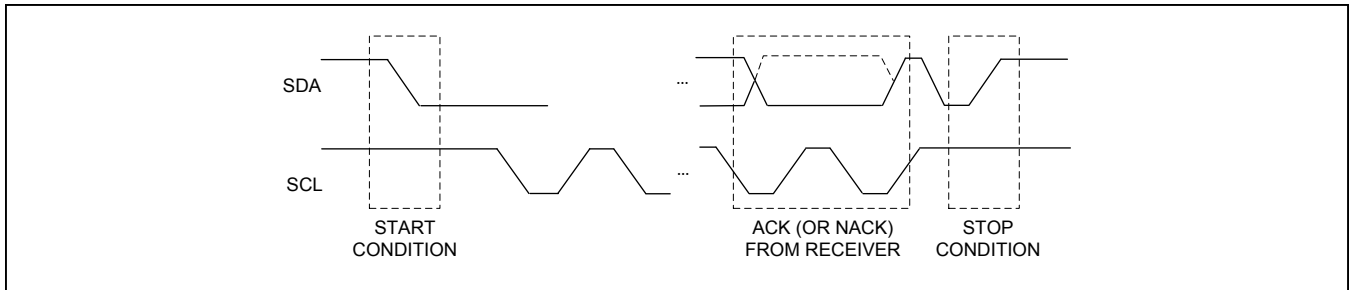

Figure 6. START, STOP, and ACK Signals

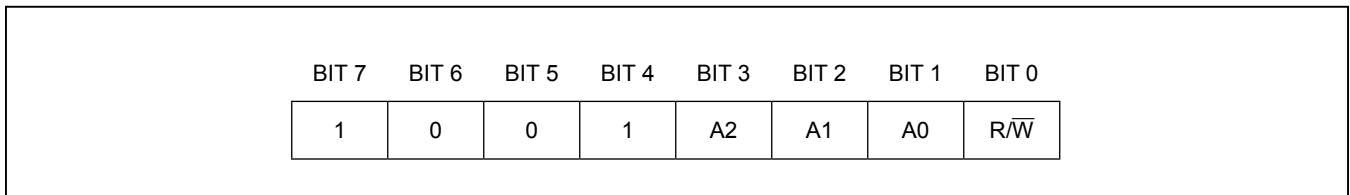

Figure 7. Address Byte

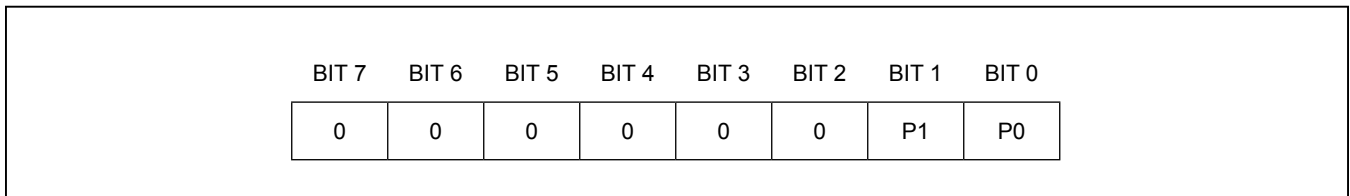

Figure 8. Pointer Byte

General 2-Wire Information

- All data is transmitted MSb first over the 2-wire bus.
- One bit of data is transmitted on the 2-wire bus each SCL period.
- A pullup resistor is required on the SDA line and, when the bus is idle, both SDA and SCL must remain in a logic-high state.
- All bus communication must be initiated with a START condition and terminated with a STOP condition. During a START or STOP is the only time SDA is allowed to change states while SCL is high. At all other times, changes on the SDA line can only occur when SCL is low: SDA must remain stable when SCL is high.
- After every 8-bit (1-byte) transfer, the receiving device must answer with an ACK (or NACK), which takes one SCL period. Therefore, nine clocks are required for every one-byte data transfer.

Writing to the DS75LV: To write to the DS75LV, the master must generate a START followed by an address byte containing the DS75LV bus address. The value of the R/W bit must be a 0, which indicates that a write is about to take place. The DS75LV responds with an ACK after receiving the address byte. The master then sends a pointer byte which tells the DS75LV which register is being written to. The DS75LV again responds with an ACK after receiving the pointer byte. Following this ACK the master device must immediately begin transmitting data to the DS75LV. When writing to the configuration register, the master must send one byte of data (see [Figure 9b](#)), and when writing to the T_{OS} or T_{HYST} registers the master must send two bytes of data (see [Figure 9c](#)). After receiving each data byte, the DS75LV responds with an ACK, and the transaction is finished with a STOP from the master.

Software POR: The soft power-on reset (POR) command is 54h. The master sends a START followed by an address byte containing the DS75LV bus address. The R/W bit must be a 0. The DS75LV responds with an ACK. If the next byte is a 0x54, the DS75LV resets as if power had been cycled. No ACK is sent by the IC after the POR command is received.

Reading from the DS75LV: When reading from the DS75LV, if the pointer was already pointed to the desired register during a previous transaction, the read can be performed immediately without changing the pointer setting. In this case the master sends a START followed by an address byte containing the DS75LV bus address. The R/W bit must be a 1, which tells the DS75LV that a read is being performed. After the DS75LV sends an ACK in response to the address byte, the DS75LV begins transmitting the requested data on the next clock cycle. When reading from the configuration register, the DS75LV transmits one byte of data, after which the master must respond with a NACK followed by a STOP (see [Figure 9e](#)). For two-byte reads (i.e., from the Temperature, T_{OS} or T_{HYST} register), the DS75LV transmits two bytes of data, and the master must respond to the first data byte with an ACK and to the second byte with a NACK followed by a STOP (see [Figure 9a](#)). If only the most significant byte of data is needed, the master can issue

a NACK followed by a STOP after reading the first data byte in which case the transaction is the same as for a read from the configuration register.

If the pointer is not already pointing to the desired register, the pointer must first be updated as shown in [Figure 9d](#), which shows a pointer update followed by a single-byte read. The value of the R/W bit in the initial address byte is a 0 (“write”) since the master is going to write a pointer byte to the DS75LV. After the DS75LV responds to the address byte with an ACK, the master sends a pointer byte that corresponds to the desired register. The master must then perform a repeated start followed by a standard one or two byte read sequence (with R/W = 1) as described in the previous paragraph.

Bus Timeout: The DS75LV has a bus timeout feature that prevents communication errors from leaving the IC in a state where SDA is held low disrupting other devices on the bus. If the DS75LV holds the SDA line low for a period of t_{TIMEOUT}, its bus interface automatically resets and release the SDA line. Bus communication frequency must be fast enough to prevent a reset during normal operation. The bus timeout feature only applies to when the DS75LV is holding SDA low. Other devices can hold SDA low for an undefined period without causing the interface to reset.

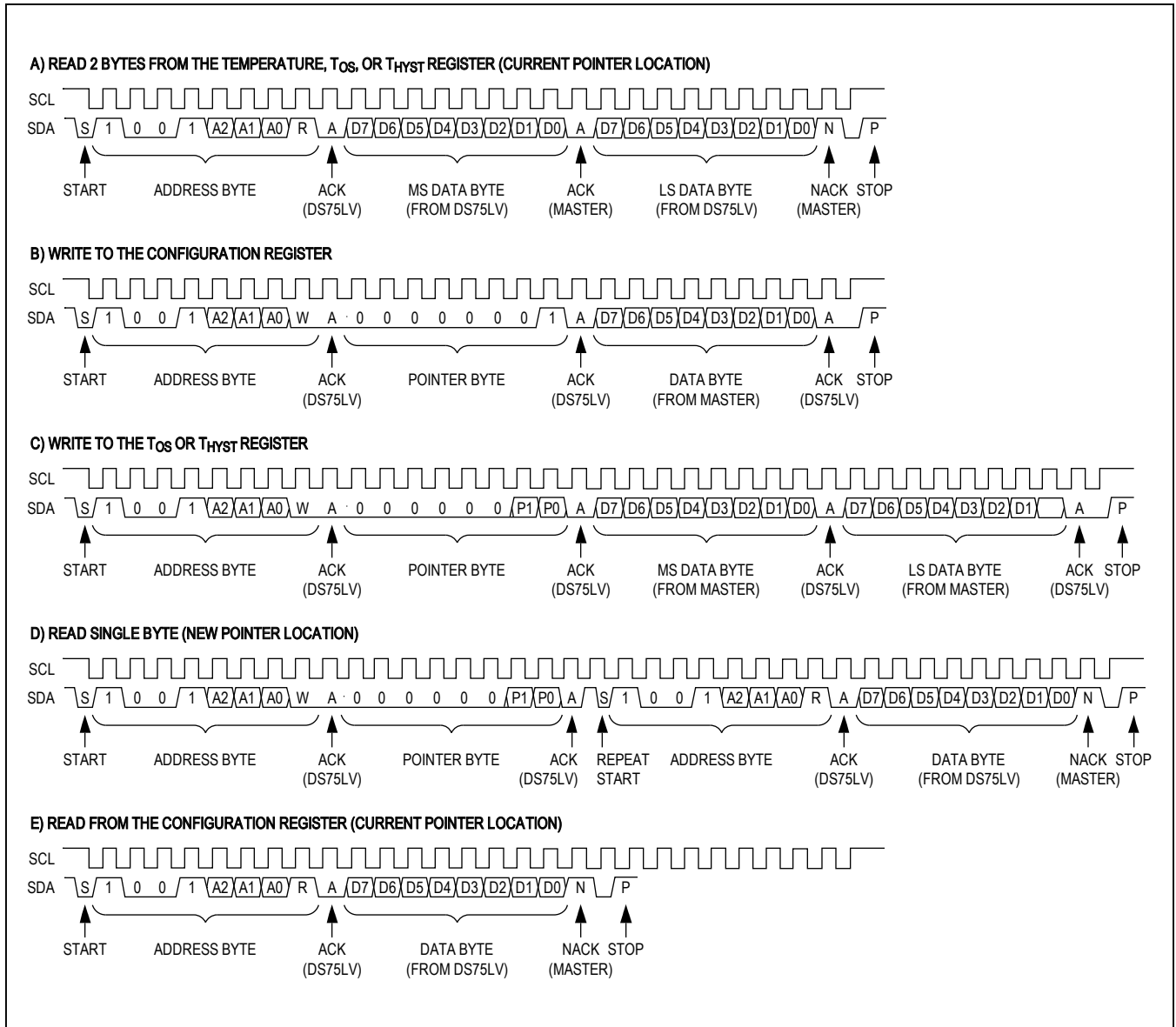

Figure 9. 2-Wire Interface Timing

Ordering Information

PART	TEMP RANGE	TOP MARK	PIN-PACKAGE
DS75LVS+	-55°C to +125°C	DS75L*	8 SO
DS75LVS+T&R	-55°C to +125°C	DS75L*	8 SO
DS75LVU+	-55°C to +125°C	DS75L	8 μ SOP (μ MAX [®])
DS75LVU+T&R	-55°C to +125°C	DS75L	8 μ SOP (μ MAX)

+Denotes a lead(Pb)-free/RoHS-compliant package.

T&R = Tape and reel.

*A "+" symbol is also marked on the package near the pin 1 indicator.

Package Information

For the latest package outline information and land patterns (footprints), go to www.maximintegrated.com/packages. Note that a "+", "#", or "-" in the package code indicates RoHS status only. Package drawings may show a different suffix character, but the drawing pertains to the package regardless of RoHS status.

PACKAGE TYPE	PACKAGE CODE	OUTLINE NO.	LAND PATTERN NO.
8 SO	S8+2	21-0141	90-0096
8 μ MAX	U8+1	21-0036	90-0092

μ MAX is a registered trademark of Maxim Integrated Products, Inc.

Revision History

REVISION NUMBER	REVISION DATE	DESCRIPTION	PAGES CHANGED
0	5/06	Initial release	—
1	11/06	Changed the max conversion time for R1 and R0 in Table 4	8
2	12/14	Updated <i>Benefits and Features</i> section	1
3	4/15	Revised <i>Electrical Characteristics</i> , Table 3, and <i>Ordering Information</i>	2, 3, 8, 13
4	3/16	Updated rise and fall time of SCL and SDA in <i>Electrical Characteristics</i> table	3
5	11/16	Added Thermistor Error typical specification	2

For pricing, delivery, and ordering information, please contact Maxim Direct at 1-888-629-4642, or visit Maxim Integrated's website at www.maximintegrated.com.

Maxim Integrated cannot assume responsibility for use of any circuitry other than circuitry entirely embodied in a Maxim Integrated product. No circuit patent licenses are implied. Maxim Integrated reserves the right to change the circuitry and specifications without notice at any time. The parametric values (min and max limits) shown in the *Electrical Characteristics* table are guaranteed. Other parametric values quoted in this data sheet are provided for guidance.

Mouser Electronics

Authorized Distributor

Click to View Pricing, Inventory, Delivery & Lifecycle Information:

[Maxim Integrated:](#)

[DS75LVS+T&R](#) [DS75LVU+T&R](#) [DS75LVS+](#) [DS75LVU+](#)