

PIN DESCRIPTIONS

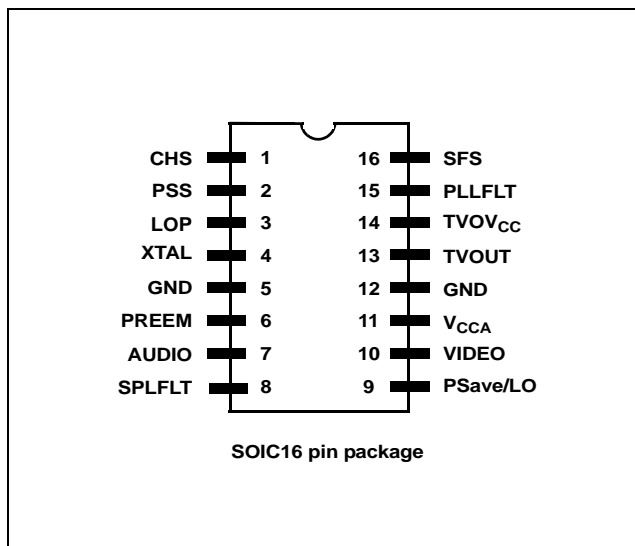

Figure 1. Pin Connections

Table 1. Package Pin Descriptions

Pin number	Pin Name	Description
1	CHS	Channel select (Low = channel 4, High = channel 3)
2	PSS	Picture-to-Sound ratio select (Low = 14 dB, High = 16 dB)
3	LOP	Logical output port controlled by pin 9
4	XTAL	Crystal / oscillator input
5	GND	Ground
6	PREEMP	Pre-emphasis capacitor
7	AUDIO _{IN}	Audio input
8	SPLFLT	Sound PLL loop filter
9	PSAVE/LO	Power save mode and LO control
10	VIDEO _{IN}	Video input
11	V _{CC}	Main analog supply voltage
12	GND	Analog ground
13	RF _{OUT}	RF output signal
14	RFOV _{CC}	RFoutput stage supply voltage
15	PLLFLT	RF PLL loop filter
16	SFS	Sound frequency select (Low = 5.5 MHz, High = MHz 4.5 MHz)

TRANSIENT OUTPUT INHIBIT

To minimize the risk of interference to other channels while the UHF PLL is acquiring a lock on the desired frequency, the Sound and Video modulators are turned OFF at power-ON (i.e., V_{CC} is switched from 0 V to 5.0 V or device is switched from “Standby mode” to “Normal operation”).

There is a time-out of 263 ms until the output is enabled. This allows the UHF PLL to settle to its programmed frequency. During the 263 ms time-out, the sound PLL current source is set to 10 μ A typical to speed up the locking time. After the 263 ms time-out, the current source is switched to 1.0 μ A. Use care when selecting loop filter components to ensure the loop transient does not exceed this delay.

VIDEO SECTION

The modulator requires a composite video input with negative going sync pulses and a nominal level of 1.0 $V_{(pp)}$. This signal is AC coupled to the video input where the sync tip level is clamped.

The video modulation depth typical value is given for 1.0 V_{CBVS} input level. It can be adjusted to any lower value by simply adding a resistive divider at video input, resulting in a lower signal seen by the video input stage.

The video signal is then passed to a peak white clip circuit whose function is to soft clip the top of the video waveform if the amplitude from the sync tip to peak white goes too high. In this way, over-modulation of the carrier by the video is avoided. The clipping function is always engaged.

SOUND SECTION

The multivibrator oscillator is fully integrated and does not require any external components. An internal low pass filter and matched structure give a very low harmonics level.

The sound modulator system consists of an FM modulator incorporating the sound subcarrier oscillator. The audio input signal is AC coupled into the amplifier which then drives the modulator.

The audio pre-emphasis circuit is a high-pass filter with an external capacitor C1 and an internal resistor (100 k Ω typical). The recommended capacitor value (750 pF) is for M/N standards, time constant is 75 μ s and it is 470 pF for B/G standards (50 μ s).

The audio bandwidth specification is for 50 Hz to 15 KHz range, with pre-emphasis circuit engaged. Without this pre-emphasis circuit, it is possible to extend the audio bandwidth to high frequencies, as there is no internal frequency limitation (stereo application).

PLL SECTION — DIVIDERS

The reference divider is a fixed +128 resulting in a reference frequency of 31.25 KHz with a 4.0 MHz crystal. The 31.25 KHz reference frequency is used for both the UHF and Sound PLLs.

The prescaler is a fixed +8 and is permanently engaged. The VHF divider is also a fixed +8.

The programmable divider's division ratio is controlled by the CHS pin voltage in order to select channel 3 or channel 4.

PIN SELECTION

Pins CHS, PSS, and SFS are internally pulled up to 5.0 V. By default (open condition), all pins are “HI”.

Table 2. Configuration Pin Settings

Pin No	Pin Name	LO (grounded)	HI (open or +5.0 V)
1	CHS	CH4	CH3
2	PSS	14 dB	16 dB
9	PSave/ LOP	Power save Mode LOP pin LO (Low voltage)	Normal Operation LOP pin HI (High impedance)
16	SFS	5.5 MHz	4.5 MHz

ELECTRICAL SPECIFICATIONS

Table 3. Absolute Maximum Ratings

Absolute maximum continuous ratings are those maximum values beyond which damage to the device may occur. Exposure to these conditions or conditions beyond those indicated may adversely affect device reliability. Functional operation at absolute-maximum-rated conditions is not implied.

Characteristic	Symbol	Min	Max	Units
Supply Voltage	V_{CC}	-0.3	+6.0	V
Any Input Voltage	V_{in}	-0.3	$V_{CC} + 0.3$	V
Storage Temperature Range	T_{stg}	-65	+150	°C
Junction Temperature	T_J	—	+150	°C

Table 4. General Specifications

Characteristic	Symbol	Min	Typ	max	Units
ESD Protection (Machine Model)	MM	200	500	—	V
ESD Protection (Human Body Model) ⁽¹⁾	HBM	4000	6000	—	V
Thermal resistance from Junction to Ambient	$R_{\theta JA}$	—	140	—	°C/W

1. MIL STD 883C method 3015-7.

Table 5. Recommended Operating Conditions and DC Characteristics

Characteristic	Symbol	Min	Typ	Max	Units	
Supply Voltage	V_{CC}	+4.5	+5.0	+5.5	V	
Total supply current (all sections active)	MC44BC375U	I_{CC}	40	47	55	mA
	MC44BC375UA	I_{CC}	40	50	57	mA
Total standby mode supply current	MC44BC375U	I_{CC}	3.0	5.0	7.0	mA
	MC44BC375UA	I_{CC}	3.0	6.0	8.0	mA
Sound comparator charge pump current:	During locking When locked		7.0	10	12	μ A
			0.7	1.0	1.5	μ A
RF comparator charge pump current		60	100	150	μ A	
Crystal oscillator stability-negative resistance		1.0	—	—	K Ω	
Threshold level on pins: CHS, PSS, SFS, Psave/LO	V_{th}	—	2.1	—	V	
Logic Output Port:	Saturation voltage at $I_{OL} = 15$ mA	V_{OL}	—	210	300	mV
	Leakage current	$I_{leakage}$	—	—	1.0	μ A
Ambient Temperature	T_A	-20	—	+85	°C	

PERFORMANCE CHARACTERISTICS

Unless otherwise stated, all performance characteristics are for:

- Power Supply, $V_{CC} = 5.0\text{ V}$
- Ambient Temperature, $T_A = 25^\circ\text{C}$
- Video Input 1.0 V_{p-p} , 10-step grayscale.
- RF inputs/outputs into 75 Ω load.

NOTE:
Specifications only valid for envelope demodulation.

The parameters listed are based on the type of test conditions found in the column Type.

- A = 100% tested
- B = 100% Correlation tested
- C = Characterized on samples
- D = Design parameter

See the “Characterization Measurement Conditions” on page 8 for each C type parameter.

Table 6. High Frequency Characteristics

Parameter	Test Conditions ⁽¹⁾	Device	Min	Typ	Max	Unit	Type
RF _{OUT} output level	Output signal from modulator section	MC44BC375U MC44BC375UA	74 78	76 80	79 83	dB μ V	B
Sound subcarrier harmonics ($F_p + n * F_s$)	Reference picture carrier	MC44BC375U MC44BC375UA	— —	.73 -72	-65 .65	dBc	C
Second harmonic of chroma subcarrier	Using red EBU bar	MC44BC375U MC44BC375UA	— —	-65 —	-55 -60	dBc	C
Chroma/Sound intermodulation: $F_p + (F_{snd} - F_{chr})$	Using red EBU bar	MC44BC375U MC44BC375UA	— —	-65 —	-60 -60	dBc	C
Fo (picture carrier) harmonics ⁽²⁾	2nd harmonic	MC44BC375U MC44BC375UA	— —	30 —	42 46	dB μ V	C
	3rd harmonic:	MC44BC375U MC44BC375UA	— —	66 —	69 73	dB μ V	C
Out band (picture carrier) spurious	$1/2 * F_o - 1/4 * F_o - 3/2 * F_o - 3/4 * F_o$	MC44BC375U MC44BC375UA	— —	— —	27 32	dB μ V	C
In band spurious ($F_o @ 5.0\text{ MHz}$)	No video sound modulation	MC44BC375U MC44BC375UA	— —	-70 —	-62 -60	dBc	C
4.0 MHz Crystal spurious ($F_o \pm 4.0\text{ MHz}$)	No video sound modulation	MC44BC375U MC44BC375UA	— —	-82 —	-75 -75	dBc	C

1. See Performance Measurement Test Set-ups, Table 9.
2. Picture carrier harmonics are highly dependant on PCB layout and decoupling capacitors.

Table 7. Video Performance Characteristics

Parameter	Test Conditions ⁽¹⁾	Min	Typ	Max	Unit	Type
Video bandwidth	Reference 0 dB at 100 KHz, measured at 5.0 MHz	-1.5	-0.5	—	dB	C
Video input level	75 Ω load	—	—	1.5	V _{cvbs}	D
Video input current		—	0.2	1.0	μ A	A
Video input impedance		—	500	—	K Ω	A
Video S/N	Weighted	56	60	—	dB	C
	Unweighted	49	52	—	—	C
Differential Phase	On line 17 in M standard (FCC)	—	± 1.0	—	deg	C
Differential Gain	On line 17 in M standard (FCC)	—	1.0	5.0	%	C
Luma/Sync ratio	Input ratio 7.0:3.0	6.8/3.2	—	7.2/2.8	—	B
Video modulation depth	Video input level = 1.0 V _{CVBS}	80	85	90	%	B
Peak White Clip	Video Modulation depth for video = 1.4 V _{CVBS}	90.5	95	99.5	%	B

1. See Performance Measurement Test Set-ups, Table 9.

MC44BC375U

Table 8. Audio Performance Characteristics

Parameter	Test Conditions ⁽¹⁾	Min	Typ	Max	Unit	Type
Picture-to-Sound ratio	PSS pin = High PSS pin = Low	14 12	16 14	18 14	dB	B
Picture to Sound ratio difference	between PSS = HI and PSS = LO	1.5	2.0	2.5	dB	B
Audio modulation depth	Using specific pre-emphasis circuit, Audio input = 1.0 KHz @ 205 mVrms					
	Fs = 4.5 MHz (100% modulation = ±25 KHz FM deviation)	75	85	95	%	B
	Fs = 5.5 MHz (100% modulation = ±50 KHz FM deviation)	75	85	95	%	B
Audio input resistance		45	55	61	KΩ	A
Audio Frequency response	Reference 0 dB at 1.0 KHz, Measure from 50 Hz to 15 KHz <i>Depends on loop filter components</i>	-2.5	—	+2.0	dB	C
Audio Distortion FM (THD only)	At 1.0 KHz, 100% modulation (±50 KHz) No video	—	0.3	1.0	%	C
Audio S/N with Sync Buzz FM		50	53	—	dB	C

1. See Performance Measurement Test Set-ups, [Table 9](#).

CHARACTERIZATION MEASUREMENT CONDITIONS

- Device default configuration unless otherwise specified:
- Sound subcarrier frequency = 5.5 MHz
 - Picture-to-sound carrier ratio = 14 dB
 - CH3 and CH4 frequencies
 - RF Inputs / Output into 75 Ω Load using a 75 to 50 Ω transformation
 - Video Input 1.0 V pk-pk
 - Audio pre-emphasis circuit engaged

Table 9. Performance Measurement Test Set-Ups

Device and Signals Set-Up	Measurement Set-Up
RF_{OUT} Output Level	
Video: 10 steps grey scale No audio	Measured picture carrier in dB μ V with the HP8596E Spectrum Analyzer using a 75 to 50 Ω transformation, all cables losses and transformation pads having been calibrated. Measurement is used as a reference for other tests: RFout_Ref
Sound Subcarrier Harmonics	
Video: 10 steps grey scale No audio signal	Measure in dBc second and third sound harmonics levels in reference to picture carrier (RFout_Ref). <div style="text-align: center;"> </div>
Second Harmonics of Chroma Subcarrier	
No audio Video: a 700 mV _(pp) 100 kHz sinusoidal signal is inserted on the black level of active video area. <div style="text-align: center;"> </div>	Measure in dBc, in reference to picture carrier (RFout_Ref), second harmonic of chroma at channel frequency plus 2 times chroma frequency, resulting in the following spectrum. <div style="text-align: center;"> </div>

Table 9. Performance Measurement Test Set-Ups (continued)

Device and Signals Set-Up	Measurement Set-Up
Chroma/Sound Intermodulation	
<p>No audio signal Video: 700 mV_(pp) 100 kHz sinusoidal signal inserted on the black level of active video area. This is generated using a Video Generator and inserting the required frequency from a RF Signal generator.</p> 	<p>Measure in dBc, in reference to picture carrier (RFout_Ref), intermodulation product at channel frequency plus the sound carrier frequency (+5.5 MHz) minus the chroma frequency (-4.43 MHz), resulting in the following spectrum. Intermodulation product is at the channel frequency +1.07 MHz.</p> 
Picture Carrier Harmonics	
<p>No video signal No audio signal</p>	<p>Measure in dBc, in reference to picture carrier (RFout_Ref), second and third harmonic of channel frequency, resulting in the following spectrum.</p> 
Out of Band Spurious	
<p>No video signal No audio signal</p>	<p>Measure in dBμV spurious levels at 0.25, 0.5, 0.75 and 1.5 times channel frequency, resulting in the following spectrum. Measure from 40 MHz to 1.0 GHz.</p> 
In Band Spurious / 4 MHz Crystal Spurious	
<p>No video signal No audio signal</p>	<p>Measure in dBc, in reference to picture carrier (RFout_Ref), spurious levels falling into video bandwidth Fo\pm5.0 MHz (15.125 KHz & 31.25 KHz from reference dividers and 4 MHz from crystal).</p>
Video Bandwidth	
<p>No audio Video: 600 mV_(pp) sinusoidal signal inserted on the black level of active video area.</p>	<p>The Video signal is demodulated on the spectrum analyzer, and the peak level of the 100 KHz signal is measured as a reference. The frequency is then swept from 100 KHz to 5.0 MHz, and then the difference in dBc from the 100 KHz reference level is measured.</p>

Table 9. Performance Measurement Test Set-Ups (continued)

Device and Signals Set-Up	Measurement Set-Up
Weighted Video Signal to Noise	
<p>Video: 100% White video signal — 1 Vpk-pk. No audio signal This is measured using a Demodulator in B/G using a CCIR Rec. 567 weighting network, 100 KHz to 5.0 MHz band with sound trap and envelope detection, and a Video Analyzer.</p>	<p>The Video Analyzer measures the ratio between the amplitude of the active area of the video signal (700 mV) and the noise level in V_{rms} on a video black level which is shown below. VideoS/N is calculated as $20 \times \log(700 / N)$ in dB.</p> <div style="text-align: center;">  <p>The diagram shows a video signal waveform with a black level. A horizontal double-headed arrow labeled 'N' indicates the noise level in V_{rms} on the black level.</p> </div>
Unweighted Video Signal to Noise	
<p>Same as above with CCIR filter disabled.</p>	<p>Same as above.</p>
Video Differential Phase	
<p>Video: 5 step Grey Scale — 1 $V_{(pp)}$. No audio signal This is measured using a Demodulator in B/G using a CCIR Rec. 567 weighting network, 100 KHz to 5.0 MHz band with sound trap, and envelope detection, and a Video Analyzer.</p>	<p>On line CCIR 330, the video analyzer DP measure consists of calculating the difference of the Chroma phase at the black level and the different chroma subcarrier phase angles at each step of the greyscale. The largest positive or negative difference indicates the distortion.</p> $\text{DIFF PHASE} = \frac{\text{the largest positive or negative difference}}{\text{the phase at position 0}} * 100\%$ <p>The video analyzer method takes the worst step from the first 4 steps.</p>
Video Differential Gain	
<p>Video: 5 step Grey Scale — 1 $V_{(pp)}$. No audio signal This is measured using a Demodulator in B/G using a CCIR Rec. 567 weighting network, 100 KHz to 5.0 MHz band with sound trap and envelope detection, and a Video Analyzer.</p>	<p>On line CCIR 330 shown below, the video analyzer DG measure consists of calculating the difference of the Chroma amplitude at the black level and the different amplitudes at each step of the greyscale. The largest positive or negative difference indicates the distortion.</p> <div style="text-align: center;">  <p>The diagram shows a 5-step greyscale with Chroma subcarrier superimposed. The steps are labeled 0, 1, 2, 3, 4, 5. The signal amplitude increases from step 0 to step 5.</p> </div> <p>5-step Greyscale with Chroma subcarrier superimposed (not to scale), line CCIR 330.</p> $\text{DIFF GAIN} = \frac{\text{the largest positive or negative difference}}{\text{the amplitude at position 0}} * 100\%$ <p>The video analyzer method takes the worst step from the first 4 steps. CCIR line 330 corresponds to FCC line 17 in NTSC/M standard.</p>

Table 9. Performance Measurement Test Set-Ups (continued)

Device and Signals Set-Up	Measurement Set-Up
Video Modulation Depth	
No audio signal Video: 10 step grey scale	This is measured using a HP8596E Spectrum Analyzer with a TV Trigger option, allowing demodulation and triggering on any specified TV Line. The analyzer is centered on the maximum peak of the Video signal and reduced to zero Hertz span in Linear mode to demodulate the Video carrier.  The Modulation Depth is calculated as $(A-B)/A \times 100$ in%.
Picture to Sound Ratio	
No video signal No audio Signal "PSS" pin set Low and High	Measure in dBc sound carrier in reference to picture carrier (RFout_Ref) for "PSS" = Low (PS = 14 dB typical) and for "PSS" = High (PS = 16 dB), 
Audio Modulation Depth — FM Modulation	
Video Black Level Audio signal: 1.0 KHz, 205 mV _{rms} . This is measured using a Demodulator in B/G and an Audio Analyzer at 1.0 KHz.	The audio signal 205 mV at 1.0 KHz is supplied by the Audio Analyzer, and the FM demodulated signal deviation is indicated on the Demodulator in KHz peak. This value is then converted in% of FM deviation, based on specified standards.
Audio Frequency Response	
Video Black Level Audio signal: 50 Hz to 15 KHz, 100 mV _{rms} This is measured using a Demodulator in B/G and an Audio Analyzer.	The audio signal 1.0 KHz 100 mV _{rms} is supplied by the Audio Analyzer, demodulated by the Demodulator and the audio analyzer measures the AC amplitude of this demodulated audio signal: this value is taken as a reference (0 dB). The audio signal is then swept from 50 Hz to 15 KHz, and demodulated AC amplitude is measured in dB relative to the 1.0 KHz reference. Audio pre-emphasis and de-emphasis circuits are engaged, all audio analyzer filters are switched OFF.
Audio Distortion FM	
Audio: 1.0 KHz, adjustable level Video Black Level This is measured using a Demodulator in B/G and an Audio Analyzer at 1.0 KHz. The output level of the Audio analyzer is varied to obtain a deviation of 50 KHz indicated on the Demodulator.	The input rms detector of the Audio Analyzer converts the ac level of the combined signal + noise + distortion to dc. It then removes the fundamental signal (1.0 KHz) after having measured the frequency. The output rms detector converts the residual noise + distortion to dc. The dc voltmeter measures both dc signals and calculates the ratio in% of the two signals. $ADist = (Distorsion + Noise)/(Distorsion + Noise + Signal)$

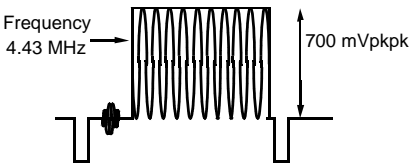
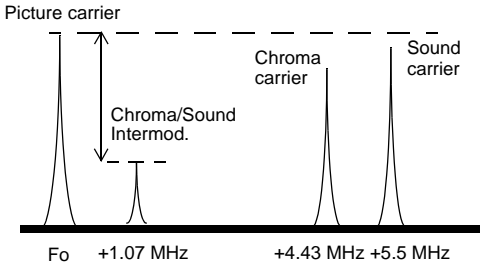
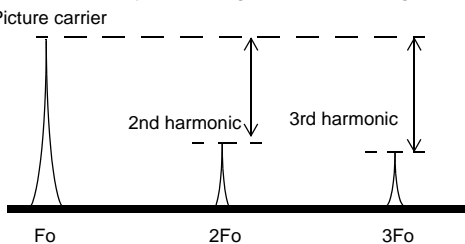
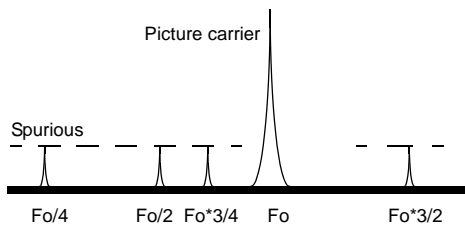
Table 9. Performance Measurement Test Set-Ups (continued)

Device and Signals Set-Up	Measurement Set-Up
Audio Signal to Noise	
<p>Audio: 1.0 KHz, adjustable level Video: EBU Color Bars This is measured using a Demodulator in B/G and an Audio Analyzer at 1.0 KHz. The output level of the Audio analyzer is varied to obtain a Modulation Deviation of 25 KHz indicated on the AMFS Demodulator.</p>	<p>The Audio Analyzer alternately turns ON and OFF its internal audio source to make a measure of the Audio signal plus noise and then another measure of only the noise. The measurement is made using the internal CCIR468-2 Filter of the Audio Analyzer together with the internal 30+/-2.0 KHz (60 dB/decade) Lowpass filters. The AMFS demodulator uses a quasi-parallel demodulation as is the case in a normal TV set. In this mode the Nyquist filter is bypassed and the video carrier is used without added delay to effectuate intercarrier conversion. In this mode the phase noise information fully cancels out and the true S/N can be measured.</p> <p style="text-align: center;">$ASN(dB) = 20 \times \log(\text{Signal} + \text{Noise}) / (\text{Noise})$</p>

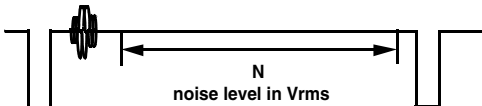
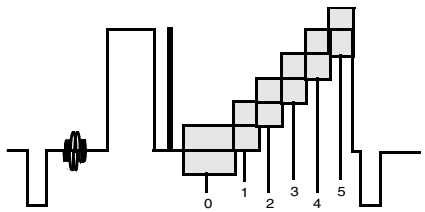
PIN CIRCUIT SCHEMATICS

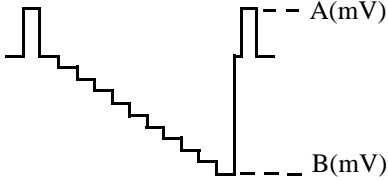
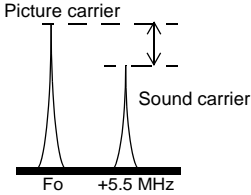
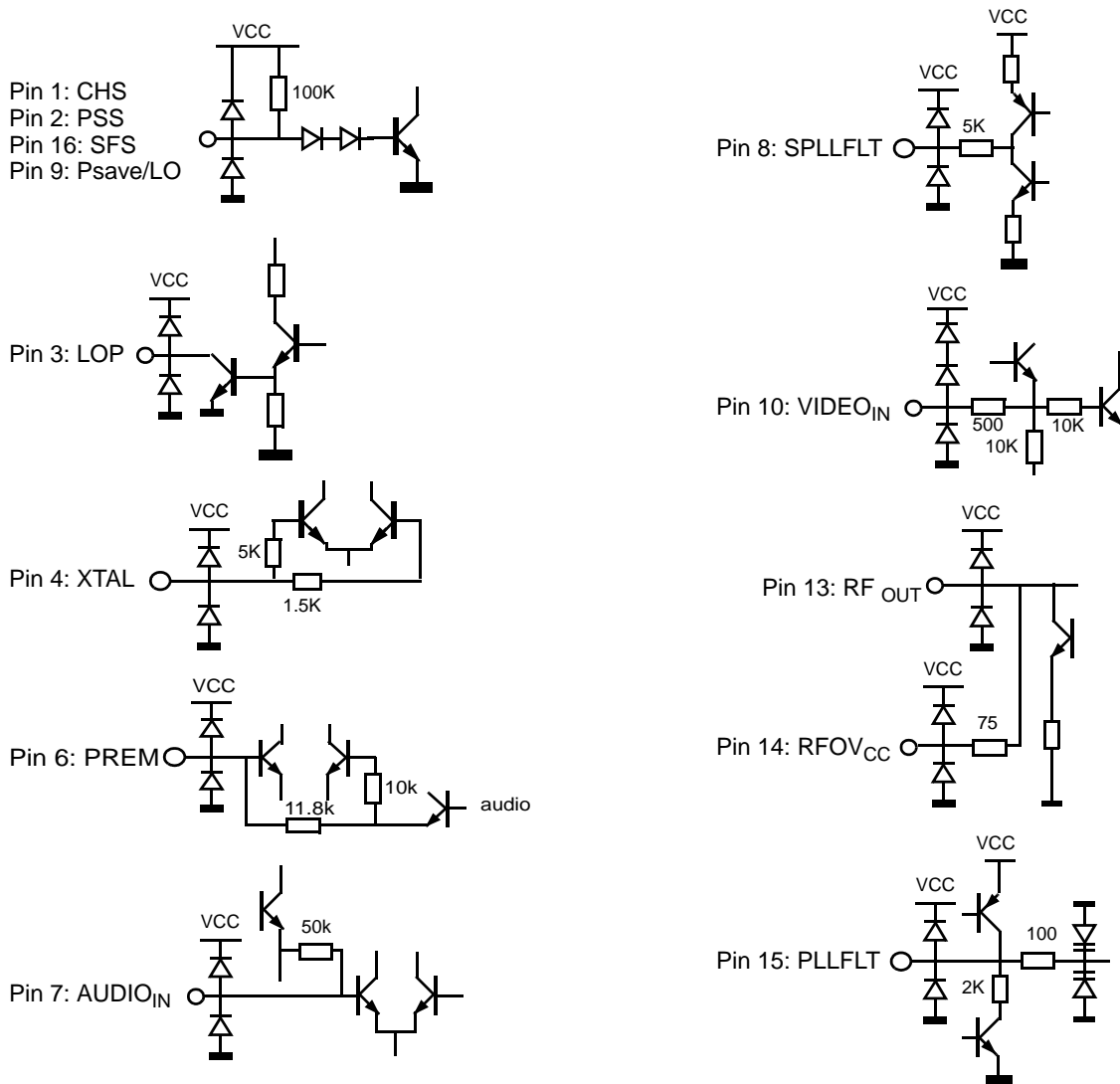
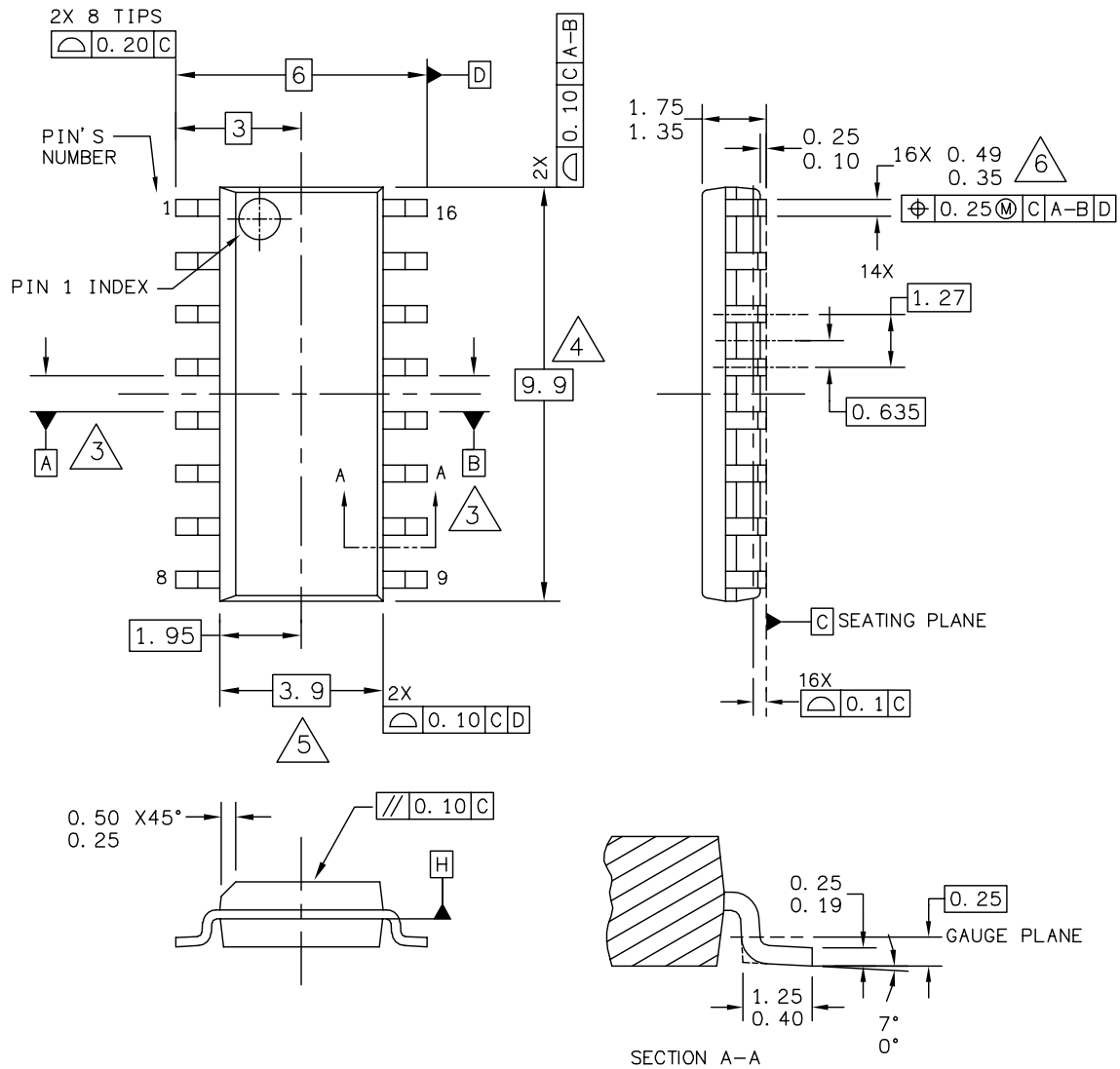

Figure 3. Pin Schematics

PACKAGE DIMENSIONS



© FREESCALE SEMICONDUCTOR, INC. ALL RIGHTS RESERVED.	MECHANICAL OUTLINE	PRINT VERSION NOT TO SCALE	
TITLE: 16LD SOIC N/B, 1.27 PITCH CASE-OUTLINE	DOCUMENT NO: 98ASB42566B	REV: M	
	CASE NUMBER: 751B-05	06 FEB 2006	
	STANDARD: JEDEC MS-012AC		

Figure 5. SOIC16 Package Dimensions

NOTES:

1. DIMENSIONS ARE IN MILLIMETERS.
2. DIMENSIONING AND TOLERANCING PER ASME Y14.5M-1994.
3. DATUMS A & B TO BE DETERMINED AT DATUM H.
4. THIS DIMENSION DOES NOT INCLUDE MOLD FLASH, PROTRUSION OR GATE BURRS. MOLD FLASH, PROTRUSION OR GATE BURRS SHALL NOT EXCEED 0.15 MM PER SIDE.
5. THIS DIMENSION DOES NOT INCLUDE INTER-LEAD FLASH OR PROTRUSIONS. INTER-LEAD FLASH AND PROTRUSIONS SHALL NOT EXCEED 0.25 MM PER SIDE. THIS DIMENSION IS DETERMINED AT THE PLANE WHERE THE BOTTOM OF THE LEADS EXIT THE PLASTIC BODY.
6. THIS DIMENSION DOES NOT INCLUDE DAMBAR PROTRUSION. ALLOWABLE DAMBAR PROTRUSION SHALL NOT CAUSE THE LEAD WIDTH TO EXCEED 0.62 mm.

© FREESCALE SEMICONDUCTOR, INC. ALL RIGHTS RESERVED.	MECHANICAL OUTLINE	PRINT VERSION NOT TO SCALE	
TITLE: 16LD SOIC N/B, 1.27 PITCH, CASE OUTLINE	DOCUMENT NO: 98ASB42566B	REV: M	
	CASE NUMBER: 751B-05	06 FEB 2006	
	STANDARD: JEDEC MS-012AC		

Figure 6. SOIC16 Package Dimensions - part 2

How to Reach Us:

Home Page:

www.freescale.com

E-mail:

support@freescale.com

USA/Europe or Locations Not Listed:

Freescale Semiconductor
Technical Information Center, CH370
1300 N. Alma School Road
Chandler, Arizona 85224
+1-800-521-6274 or +1-480-768-2130
support@freescale.com

Europe, Middle East, and Africa:

Freescale Halbleiter Deutschland GmbH
Technical Information Center
Schatzbogen 7
81829 Muenchen, Germany
+44 1296 380 456 (English)
+46 8 52200080 (English)
+49 89 92103 559 (German)
+33 1 69 35 48 48 (French)
support@freescale.com

Japan:

Freescale Semiconductor Japan Ltd.
Headquarters
ARCO Tower 15F
1-8-1, Shimo-Meguro, Meguro-ku,
Tokyo 153-0064
Japan
0120 191014 or +81 3 5437 9125
support.japan@freescale.com

Asia/Pacific:

Freescale Semiconductor Hong Kong Ltd.
Technical Information Center
2 Dai King Street
Tai Po Industrial Estate
Tai Po, N.T., Hong Kong
+800 2666 8080
support.asia@freescale.com

For Literature Requests Only:

Freescale Semiconductor Literature Distribution Center
P.O. Box 5405
Denver, Colorado 80217
1-800-441-2447 or 303-675-2140
Fax: 303-675-2150
LDCForFreescaleSemiconductor@hibbertgroup.com

Information in this document is provided solely to enable system and software implementers to use Freescale Semiconductor products. There are no express or implied copyright licenses granted hereunder to design or fabricate any integrated circuits or integrated circuits based on the information in this document.

Freescale Semiconductor reserves the right to make changes without further notice to any products herein. Freescale Semiconductor makes no warranty, representation or guarantee regarding the suitability of its products for any particular purpose, nor does Freescale Semiconductor assume any liability arising out of the application or use of any product or circuit, and specifically disclaims any and all liability, including without limitation consequential or incidental damages. "Typical" parameters that may be provided in Freescale Semiconductor data sheets and/or specifications can and do vary in different applications and actual performance may vary over time. All operating parameters, including "Typicals", must be validated for each customer application by customer's technical experts. Freescale Semiconductor does not convey any license under its patent rights nor the rights of others. Freescale Semiconductor products are not designed, intended, or authorized for use as components in systems intended for surgical implant into the body, or other applications intended to support or sustain life, or for any other application in which the failure of the Freescale Semiconductor product could create a situation where personal injury or death may occur. Should Buyer purchase or use Freescale Semiconductor products for any such unintended or unauthorized application, Buyer shall indemnify and hold Freescale Semiconductor and its officers, employees, subsidiaries, affiliates, and distributors harmless against all claims, costs, damages, and expenses, and reasonable attorney fees arising out of, directly or indirectly, any claim of personal injury or death associated with such unintended or unauthorized use, even if such claim alleges that Freescale Semiconductor was negligent regarding the design or manufacture of the part.

Freescale™ and the Freescale logo are trademarks of Freescale Semiconductor, Inc. All other product or service names are the property of their respective owners.

© Freescale Semiconductor, Inc. 2006. All rights reserved.

RoHS-compliant and/or Pb-free versions of Freescale products have the functionality and electrical characteristics of their non-RoHS-compliant and/or non-Pb-free counterparts. For further information, see <http://www.freescale.com> or contact your Freescale sales representative.

For information on Freescale's Environmental Products program, go to <http://www.freescale.com/ep>.

Mouser Electronics

Authorized Distributor

Click to View Pricing, Inventory, Delivery & Lifecycle Information:

[NXP:](#)

[MC44BC375UADEVK](#)