

TDA 7255V

Block Diagram TDA 7255V

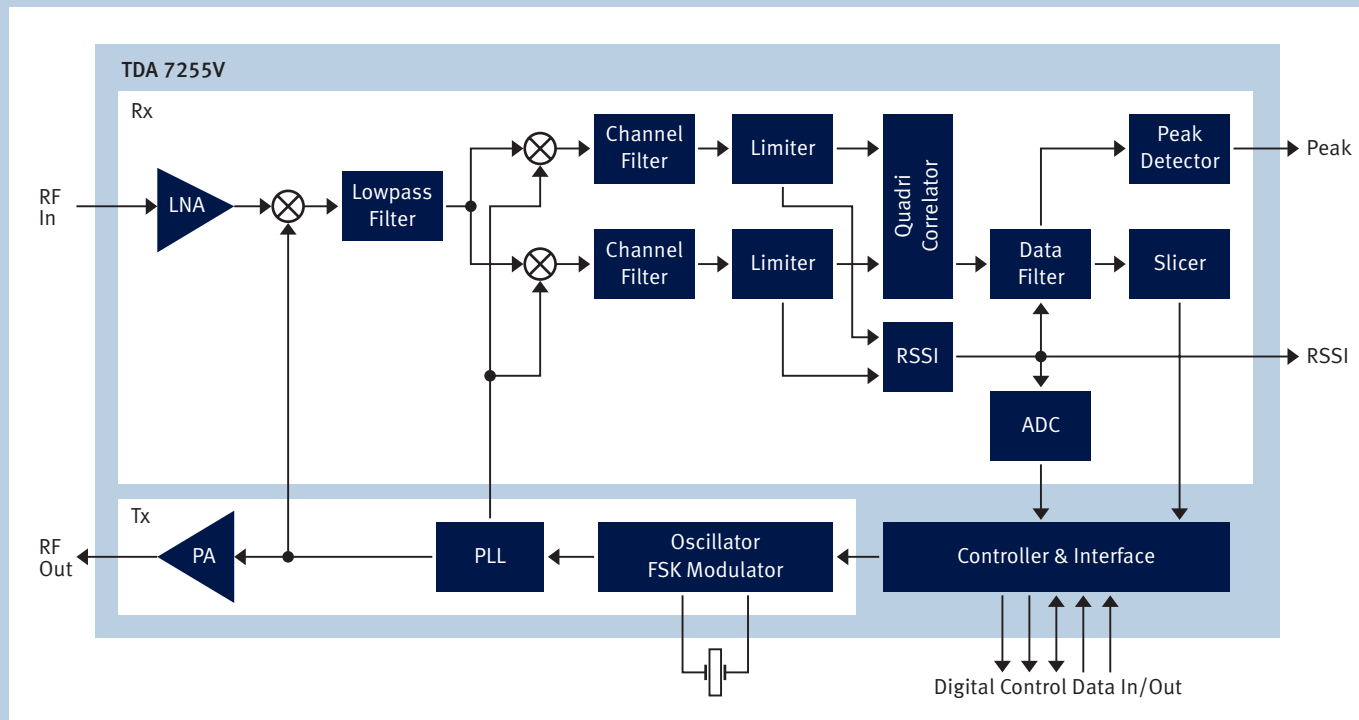

Product Summary

Feature	TDA 7255V
Frequency Range	433 ... 435MHz
Supply Voltage	2.1 ... 5.5V
Temperature Range	-40 ... +85°C
Package	PG-VQFN-40
Rx	
Supply Current typ. @ 3V	8.6mA (ASK) 9.0mA (FSK)
Sensitivity @ 4kbit/s Manchester	-112dBm (ASK) -115dBm (FSK)
Tx	
Supply Current typ. @ 3V	13.5mA
RF transmit Power typ.	9dBm

Major Blocks and its Key Benefits

The device contains a low noise amplifier (LNA), a double balanced mixer, a fully integrated VCO, a PLL synthesizer, a crystal oscillator with FSK modulator, a limiter with RSSI generator, an FSK demodulator, a data filter, a data comparator (slicer), a positive and a negative peak detector, a highly efficient class C power amplifier and a complex digital timing and control unit with I²C/3-wire microcontroller interface. Additionally there is a power down feature to save battery power.

The transmit section uses direct ASK modulation by switching the power amplifier, and crystal oscillator detuning for FSK modulation. The necessary detuning load capacitors are external. The capacitors for fine tuning are integrated. The receive section is using a novel single-conversion/direct-conversion scheme that is combining the advantages of both receive topologies. The IF is contained on the chip, no RF channel filters are necessary as the channel filter is also on the chip. The self-polling logic can be used to let the device operate autonomously as a master for a decoding microcontroller.

Published by
Infineon Technologies AG
85579 Neubiberg, Germany

© 2010 Infineon Technologies AG.
All Rights Reserved.

Visit us:
www.infineon.com

Order Number: B142-H9511-X-X-7600
Date: 08 / 2010

ATTENTION PLEASE!

The information given in this document shall in no event be regarded as a guarantee of conditions or characteristics ("Beschaffenheitsgarantie"). With respect to any examples or hints given herein, any typical values stated herein and/or any information regarding the application of the device, Infineon Technologies hereby disclaims any and all warranties and liabilities of any kind, including without limitation warranties of non-infringement of intellectual property rights of any third party.

INFORMATION

For further information on technology, delivery terms and conditions and prices please contact your nearest Infineon Technologies Office (www.infineon.com).

WARNINGS

Due to technical requirements components may contain dangerous substances. For information on the types in question please contact your nearest Infineon Technologies Office. Infineon Technologies Components may only be used in life-support devices or systems with the express written approval of Infineon Technologies, if a failure of such components can reasonably be expected to cause the failure of that life-support device or system, or to affect the safety or effectiveness of that device or system. Life support devices or systems are intended to be implanted in the human body, or to support and/or maintain and sustain and/or protect human life. If they fail, it is reasonable to assume that the health of the user or other persons may be endangered.

Mouser Electronics

Authorized Distributor

Click to View Pricing, Inventory, Delivery & Lifecycle Information:

[Infineon:](#)

[TDA5255](#) [TDA7255V](#)