

Aug.1.2021 Copyright 2021 HIROSE ELECTRIC CO., LTD. All Rights Reserved.  
In case of consideration for using Automotive equipment / device which demand high reliability, kindly contact our sales window correspondents.

◆ RECOMMENDED PCB LAYOUT (MOUNTING SURFACE SIDE)

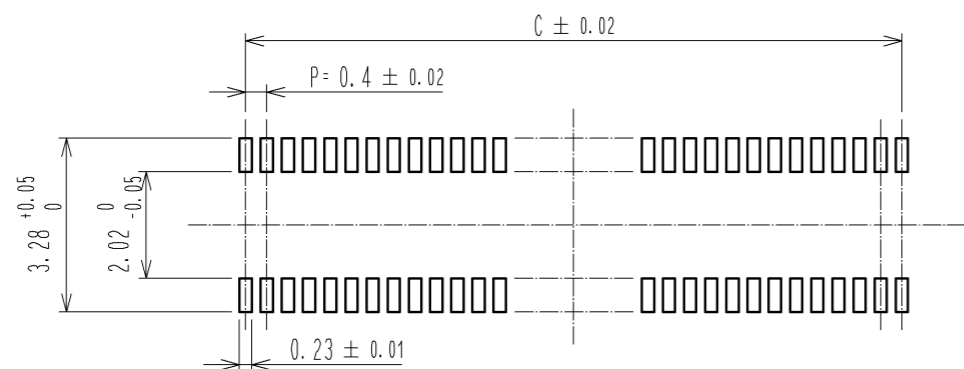

◆ RECOMMENDED METAL MASK DIMENSIONS  
METAL MASK THICKNESS : 0.12mm

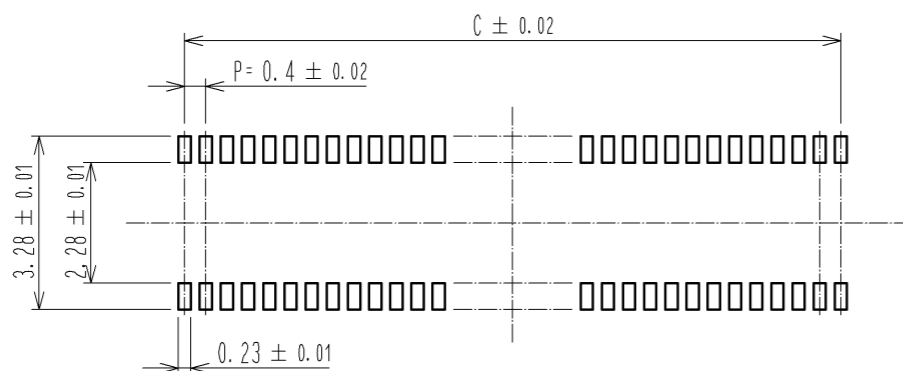

◆ RECOMMENDED METAL MASK DIMENSIONS  
METAL MASK THICKNESS : 0.1mm

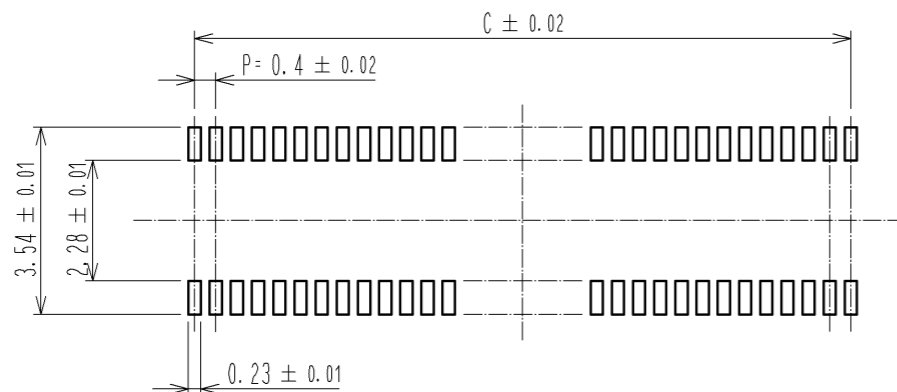

③ RECOMMENDED REFLOW TEMPERATURE PROFILE USING LEAD-FREE SOLDER PASTE.

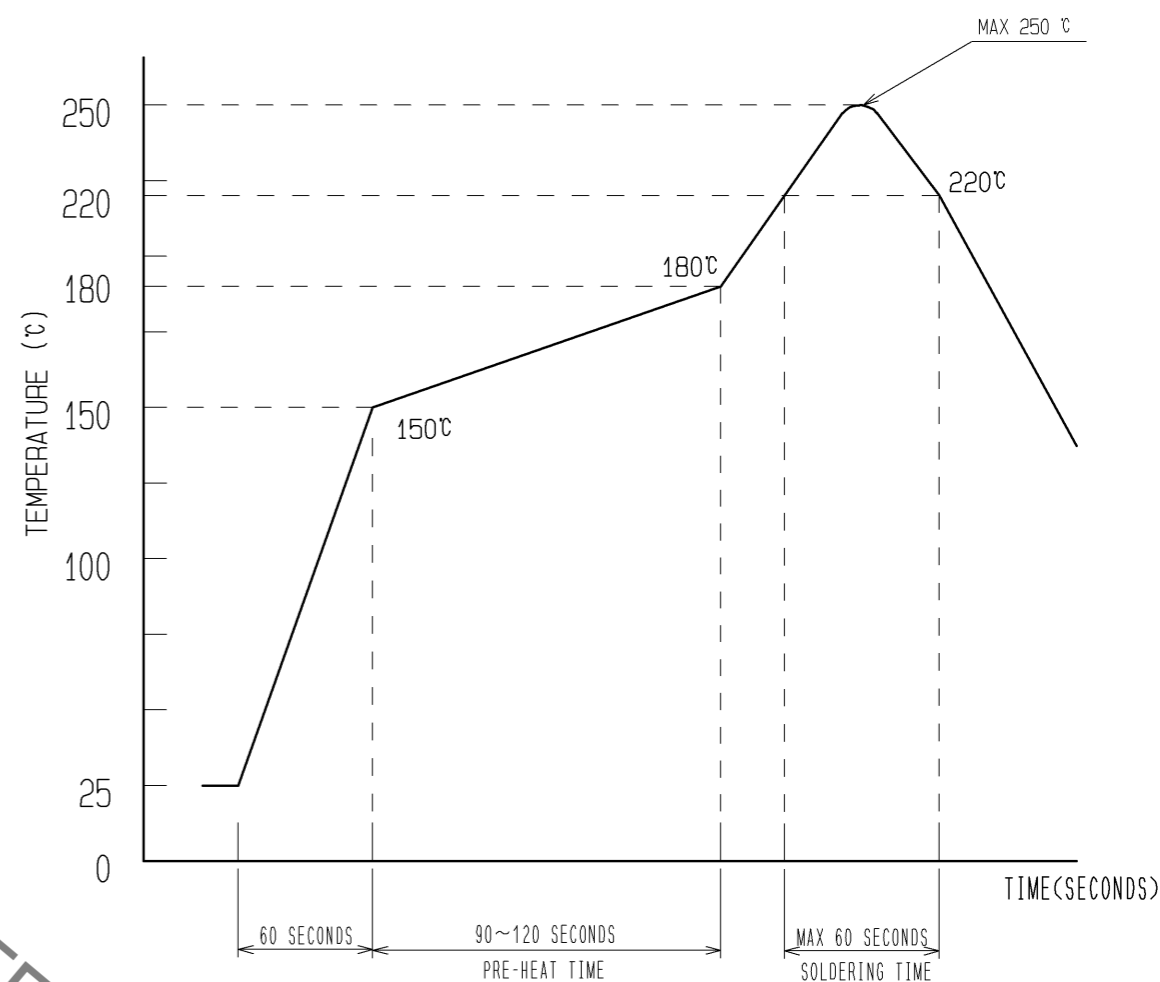

- 1) REFLOW TIME  
REFLOW METHOD: IR REFLOW  
NUMBER OF REFLOW CYCLES: 2 CYCLES MAX.  
DURATION ABOVE 220 °C, 60 SEC. MAX.  
(PEAK TEMPERATURE: 250°C MAX.)
- 2) PRE-HEAT TIME  
PRE-HEAT TEMPERATURE(MIN) : 150 °C  
PRE-HEAT TEMPERATURE(MAX) : 180 °C  
PRE-HEAT TIME : 90~120 sec.

③ THIS TEMPERATURE PROFILE IS PER THE CONDITIONS SHOWN ABOVE. ADDITIONAL FACTORS, SUCH AS SOLDER PASTE TYPE, PCB SIZE AND OTHER MOUNTED COMPONENTS COULD AFFECT THE PROFILE. THEREFORE, A THOROUGH EVALUATION OF MOUNTING CONDITION IS REQUIRED PRIOR TO PRODUCTION. TEMPERATURE IS MEASURED AT CONTACT LEAD.

PART No.	C
DF37NC-10DS-0.4V(51)	1.6
DF37NC-16DS-0.4V(51)	2.8
DF37NC-20DS-0.4V(51)	3.6
DF37NC-24DS-0.4V(51)	4.4
DF37NC-30DS-0.4V(51)	5.6
DF37NC-34DS-0.4V(51)	6.4
DF37NC-40DS-0.4V(51)	7.6
DF37NC-44DS-0.4V(51)	8.4
DF37NC-50DS-0.4V(51)	9.6
DF37NC-60DS-0.4V(51)	11.6
DF37NC-70DS-0.4V(51)	13.6
DF37NC-74DS-0.4V(51)	14.4

<b>HRS</b>	DRAWING NO.	EDC3-319684-01
	PART NO.	DF37NC-*DS-0.4V(51)
	CODE NO.	
	① 2/3	

Aug.1.2021 Copyright 2021 HIROSE ELECTRIC CO., LTD. All Rights Reserved.  
In case of consideration for using Automotive equipment / device which demand high reliability, kindly contact our sales window correspondents.

### EMBOSSED CARRIER TAPE PACKAGING (FREE SIZE)

◆MORE THAN 20 POS.

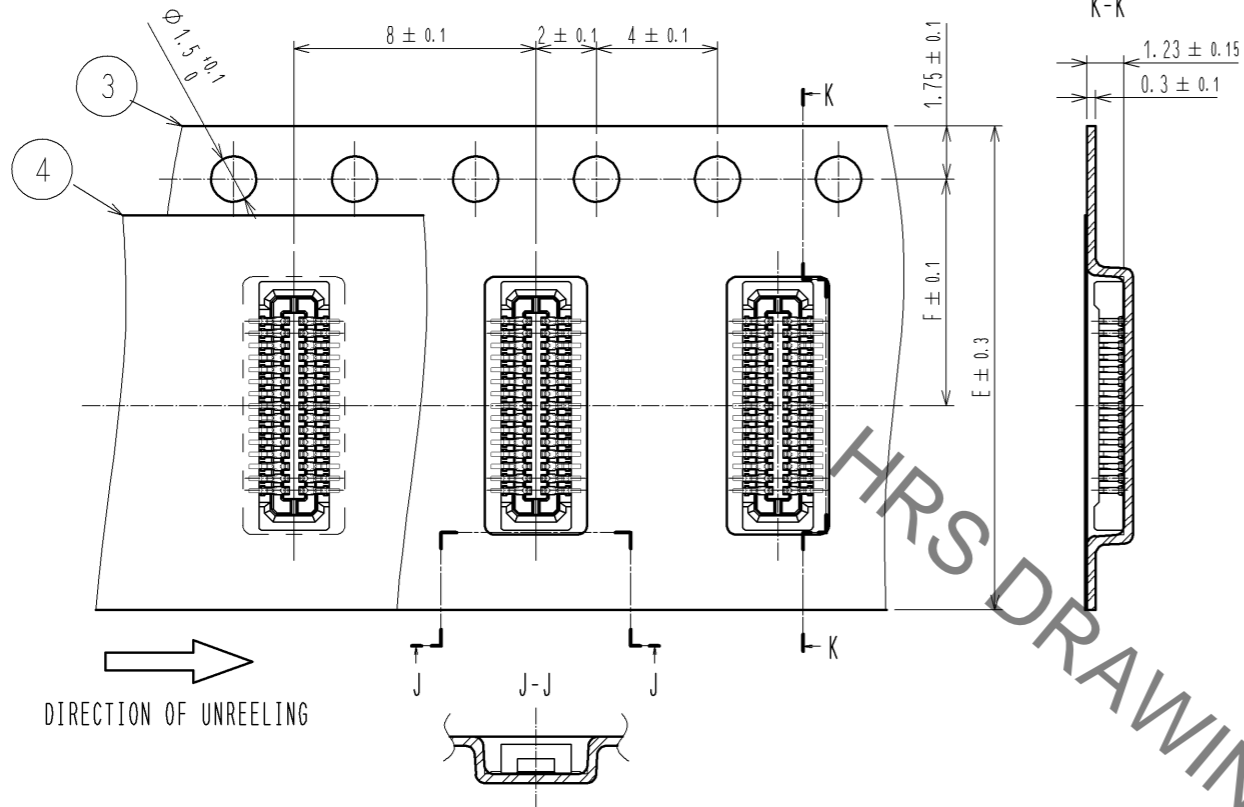

### EMBOSSED CARRIER TAPE PACKAGING (FREE SIZE)

◆LESS THAN 20 POS.

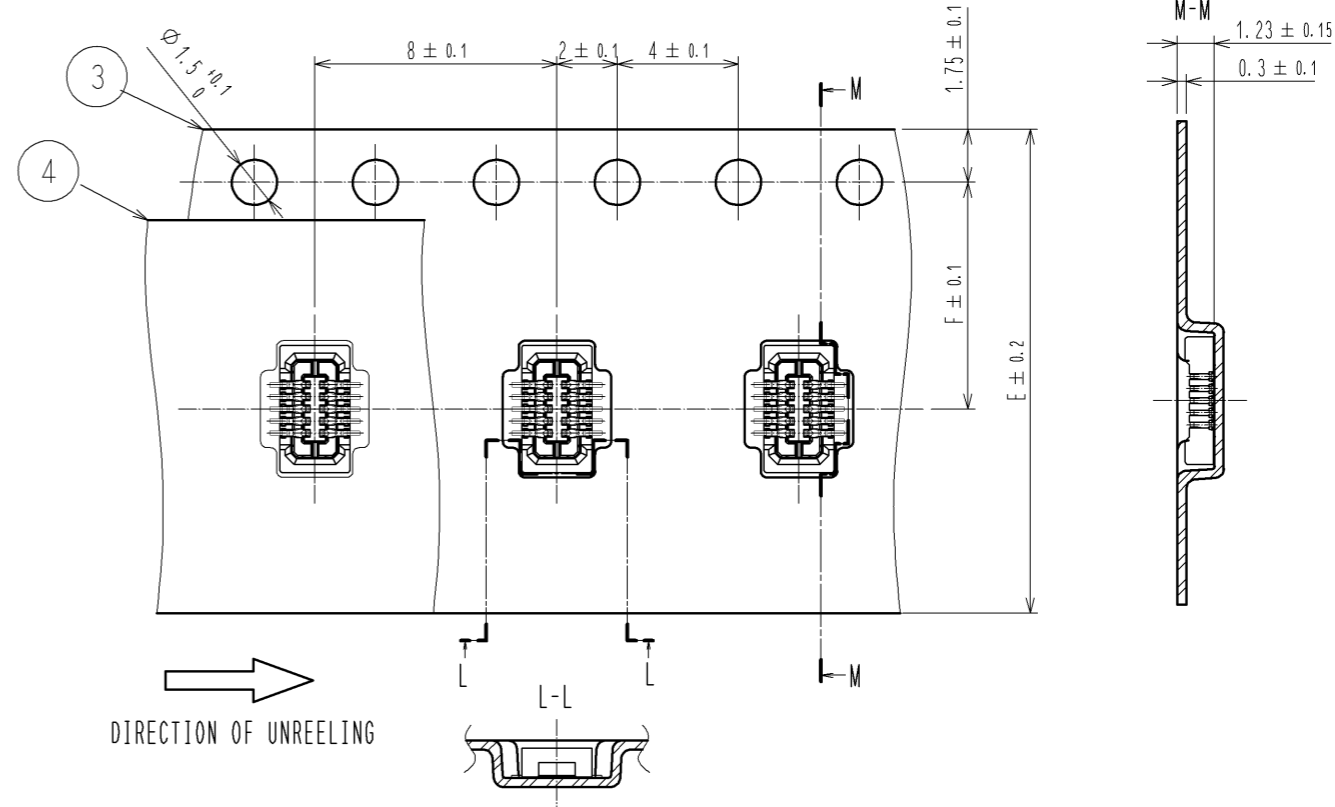

### STYLE AND DIMENSION OF REEL (FREE SIZE)

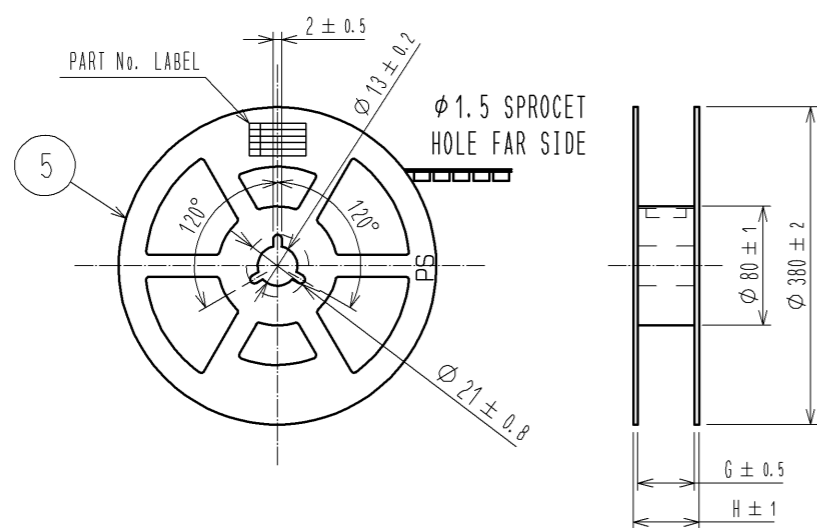

### 7) DETAIL OF PART No. LABEL

SUPPLIER	HIROSE ELECTRIC CO., LTD.
QUANTITY	8000個
PART NO.	DF37NC-DS-0.4V(51)
CODE NO.	** ** *
DATE OF MANUFACTURED	年 月 日
製造年月日	年 月 日
製品コード	** ** *
製品名	DF37NC-DS-0.4V(51)
数量	8000個
納入者	ヒロセ電機(株)

PART No.	E	F	G	H
DF37NC-10DS-0.4V(51)	16	7.5	17.5	21.5
DF37NC-16DS-0.4V(51)	16	7.5	17.5	21.5
DF37NC-20DS-0.4V(51)	16	7.5	17.5	21.5
DF37NC-24DS-0.4V(51)	16	7.5	17.5	21.5
DF37NC-30DS-0.4V(51)	24	11.5	25.5	29.5
DF37NC-34DS-0.4V(51)	24	11.5	25.5	29.5
DF37NC-40DS-0.4V(51)	24	11.5	25.5	29.5
DF37NC-44DS-0.4V(51)	24	11.5	25.5	29.5
DF37NC-50DS-0.4V(51)	24	11.5	25.5	29.5
DF37NC-60DS-0.4V(51)	24	11.5	25.5	29.5
DF37NC-70DS-0.4V(51)	32	14.2	33.5	37.5
DF37NC-74DS-0.4V(51)	32	14.2	33.5	37.5

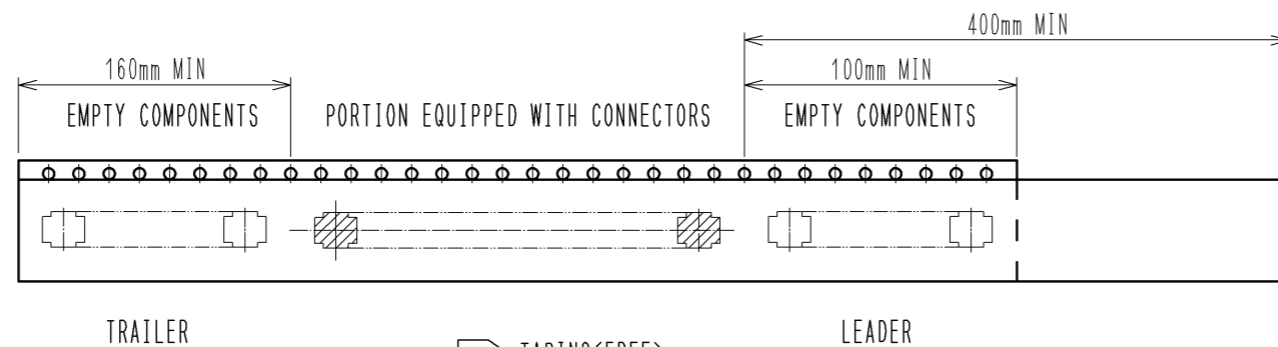

- NOTES 4. PER REEL 8000 CONNECTORS.  
5. THE DIMENSIONS IN PARENTHESES ARE FOR REFERENCE.  
6) REFER TO JIS C 0806(PACKING OF COMPONENTS FOR AUTOMATIC HANDLING)  
7) DETAIL OF PART No. LABEL IS WRITTEN IN JAPANESE.

<b>HRS</b>	DRAWING NO.	EDC3-319684-01
	PART NO.	DF37NC-DS-0.4V(51)
	CODE NO.	

# Mouser Electronics

Authorized Distributor

Click to View Pricing, Inventory, Delivery & Lifecycle Information:

[Hirose Electric:](#)

[DF37NC-24DS-0.4V\(51\)](#)