

**POWER MANAGEMENT**
**Absolute Maximum Ratings**

Exceeding the specifications below may result in permanent damage to the device, or device malfunction. Operation outside of the parameters specified in the Electrical Characteristics section is not implied.

Parameter	Symbol	Maximum	Units
Input Voltage	$V_{IN}$ to GND	-0.3 to 20	V
Storage Temperature Range	$T_{STG}$	-45 to +150	°C
Maximum Junction Temperature	$T_J$	150	°C
Lead Temperature (Soldering) 10 Sec.	$T_{LEAD}$	300	°C
Thermal Resistance, Junction to Ambient <sup>(1)</sup>	$\theta_{JA}$	165	°C/W
Thermal Resistance, Junction to Case	$\theta_{JC}$	102	°C/W
Electrical Surge Discharge <sup>(2)</sup>	ESD	2	KV

Note:

(1) Mounting pad has to be larger than one square inch on two sided printed circuit board with minimum 1 ounce copper

(2) Human model.

**Electrical Characteristics**

$V_{IN} = 12V$ ;  $V_O = 25V$ ;  $T_A = T_J = -40^\circ C$  to  $125^\circ C$  unless otherwise specified.

Parameter	Symbols	Conditions	Min	Typ	Max	Units
Reference	$V_{REF}$		1.225	1.250	1.275	V
Feedback Bias Current	$I_{FB}$	$V_{FB} = V_{EN/SS}$ , $V_{IN} = 12V$		2.0	8.0	$\mu A$
Quiescent Current	$I_Q$	Current into $V_{IN}$ pin		5.0	8.0	mA
Load Regulation		$V_O = 25V$ ; $I_O = 0.1A$ to $1A$		0.5	1.0	%
Line Regulation		$V_{IN} = 5V$ to $15V$ ; $V_O = 25V$ ; $I_O = 100mA$		1.4	2	%
Current Limit Threshold		CS	68	73	78	mV
Oscillator Frequency		$T_A = 25^\circ C$	190	200	210	kHz
Oscillator Frequency Shift		$V_{FB} < V_{REF}/2$		50		kHz
Max Duty Cycle			90	95		%
UVLO Threshold	$V_{UVLO}$	$V_{IN}$ ramping up		4.2	4.5	V
UVLO Hysteresis				400		mV
Driver Source Current	$I_{SOURCE}$	$V_{IN} = 12V$ , $C_{GATE} = 10nF$	0.5	0.8	1.1	A
Driver Sink Current	$I_{SINK}$	$V_{IN} = 12V$ , $C_{GATE} = 10nF$	0.5	0.8	1.1	A
Soft Start Charge Current	$I_{SS}$			60		$\mu A$
Internal Ramp Peak	$V_{R\_PEAK}$			1.4		V
Internal Ramp Valley	$V_{R\_VALLEY}$			0.4		V
Enable Threshold	$V_{TH\_EN}$	Pull down below this level to disable the output	0.09	0.12		V

**POWER MANAGEMENT**

**Pin Configuration**

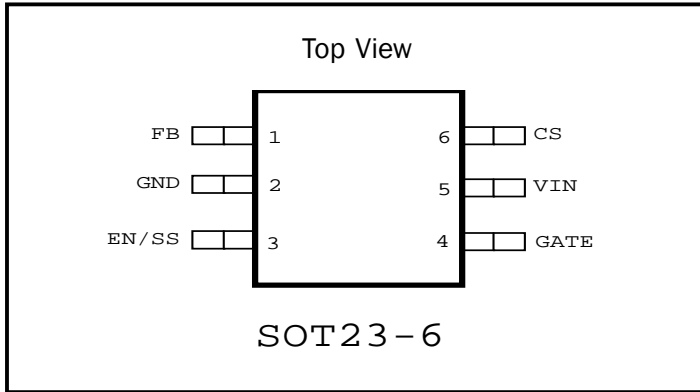

**Ordering Information**

Part Numbers	Package
SC2603SKTRT <sup>(1)(2)</sup>	SOT23-6
SC2603EVB	

**Note:**

(1) Only available in tape and reel packaging. A reel contains 3000 devices.

(2) Lead free product. This product is fully WEEE and RoHS compliant

**Pin Descriptions**

Pin #	Pin Name	Pin Function
1	FB	Error amplifier input (-).
2	GND	Device ground.
3	EN/SS	Enable/Soft Start Pin.
4	Gate	Gate driver output.
5	VIN	Device Input Voltage.
6	CS	Current Sense Input .

**Block Diagram**

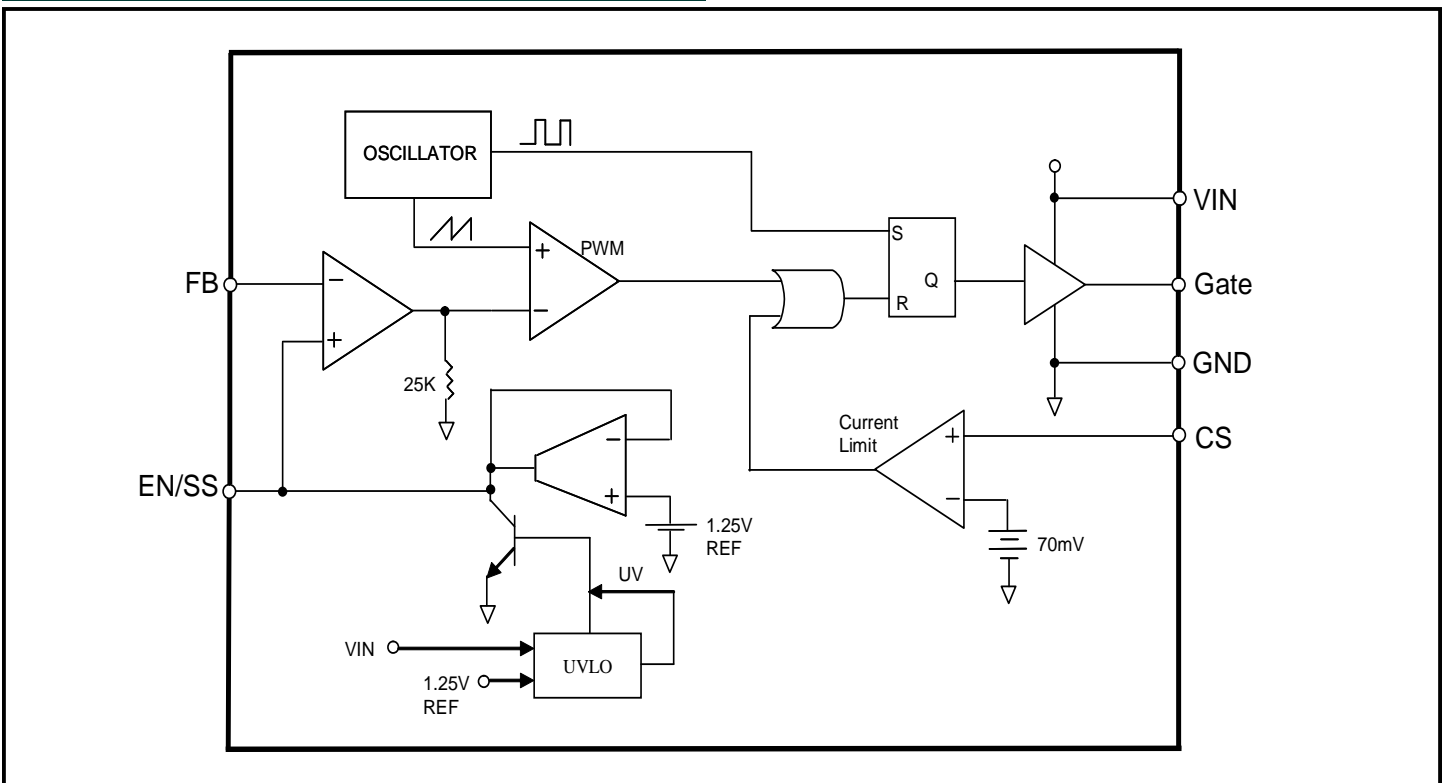

**POWER MANAGEMENT**
**Theory of Operation**

The SC2603 is a versatile, low-cost, voltage-mode PWM controller designed for DC/DC power supply applications. In normal condition, the SC2603 operates at a fixed 200KHz. One exception is that when the FB pin voltage drops to one half, the frequency will be shifted to one fourth of 200KHz.

SC2603 features include a temperature compensated voltage reference, triangle wave oscillator, current limit comparator, frequency shift over-current protection, and an internally compensated error amplifier. Pulse by pulse current limiting is implemented by sensing the differential voltage across an external resistor, or an appropriately sized PC board trace.

**Application Information**
**Soft-Start**

Soft-start prevents a DC-DC converter from drawing excessive current from the power source during start up. If the soft-start time is made sufficiently long, then the output will enter regulation without overshoot. An external capacitor is connected from the EN/SS pin to the ground. After the part's input voltage surpasses the UVLO, the EN/SS pin is allowed to charge its capacitor with 60µA. When 100mV is reached at the EN/SS pin, the internal comp node is at 0.4V. The SC2603 will start switching, and the converter output comes into regulation. Because the FB pin voltage follows EN/SS pin voltage, finally, the EN/SS pin voltage will be clamped at 1.25V same as the reference voltage.

**Setting the Output Voltage**

An external resistive divider  $R_1$  and  $R_2$  with its center tap tied to the FB pin sets the output voltage.

$$R_1 = R_2 \left( \frac{V_{OUT}}{1.25} - 1 \right)$$

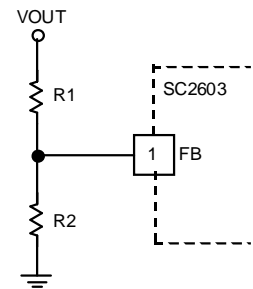
**Under Voltage Lockout**

The under voltage lockout circuit of the SC2603 assures that the gate driver output remains in the off state whenever the supply voltage drops below set parameters. Lock-out occurs if  $V_{IN}$  falls below 3.8V. Normal operation resumes once  $V_{IN}$  rises above 4.2V.

**POWER MANAGEMENT**

**Application Information**

**Over Current Protection**

The over-current protection is implemented by a sensing resistor and an internal current-limit comparator with a threshold of 70mV. If the switching current through the sensing resistor causing voltage to drop at the CS pin reaches 70mV, the SC2603 will immediately turn the gate pulse off to limit the current through the power switch. The figure below shows over-current waveforms. At t1, the input current  $I_{IN}$  begins to increase as the load  $I_{OUT}$  builds up until it hits the OCP threshold at t2. At t2,  $V_{OUT}$  begins to drop as  $I_{OUT}$  starts increasing toward t3 while  $V_{IN}$  and  $I_{IN}$  remain the same. At t3, there two events are happening. 1)  $V_{OUT}$  is at half of its regulating voltage. At this point, the internal oscillator runs into frequency shift mode and shifts the frequency to one fourth of the operating frequency. 2) The diode starts conducting current without limit causing  $V_{IN}$  to fall due to supply current limit. Finally,  $V_{IN}$  and  $V_{OUT}$  both drops to zero and  $I_{IN}$  becomes the input supply current limit.

A RC filter at the CS pin is necessary to filter out noise to ensure accurate sensing. The value of the sensing resistor can be calculated by the following equation:

$$R_s = 70\text{ mV} / I_{PEAK}$$

Where  $I_{PEAK}$  is the input peak current through the power MOSFET.

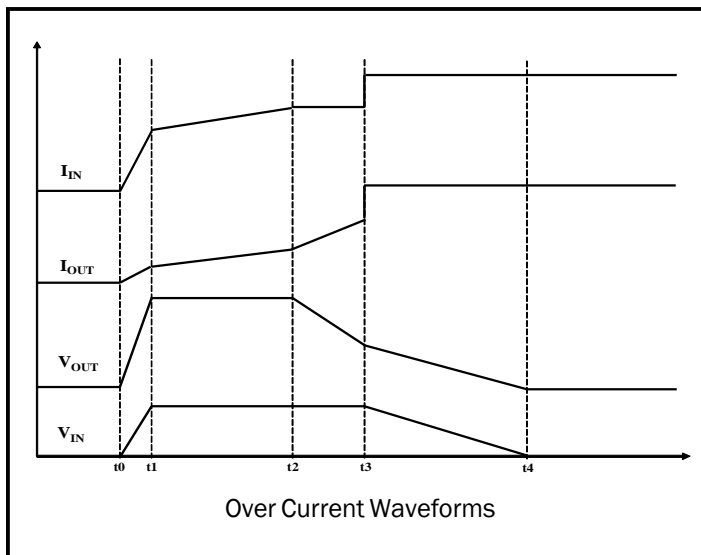

**POWER MANAGEMENT****Applications Information****Layout Guidelines**

Careful attention to layout requirements are necessary for successful implementation of the SC2603 PWM controller. High currents switching at 200kHz are present in the application and their effect on ground plane voltage differentials must be understood and minimized.

- 1) The high power parts of the circuit should be laid out first. A ground plane should be used, the number and position of ground plane interruptions should be such as to not unnecessarily compromise ground plane integrity. Isolated or semi-isolated areas of the ground plane may be deliberately introduced to constrain ground currents to particular areas, for example the input capacitor and bottom Schottky ground.
- 2) The loop formed by the output Capacitor(s) ( $C_{out}$ ), the FET (Q1), the current sensing resistor, and the Schottky (D1) must be kept as small as possible. This loop contains all the high current, fast transition switching. Connections should be as wide and as short as possible to minimize loop inductance. Minimizing this loop area will reduce EMI, lower ground injection currents, resulting in electrically “cleaner” grounds for the rest of the system and minimize source ringing, resulting in more reliable gate switching signals.
- 3) The connection between the junction of Q1, D1 and the output capacitor should be a wide trace or copper region. It should be as short as practical. Since this connection has fast voltage transitions, keeping this connection short will minimize EMI.
- 4) The Output Capacitor(s) ( $C_{out}$ ) should be located as close to the load as possible, fast transient load currents are supplied by  $C_{out}$  only, and connections between  $C_{out}$  and the load must be short, wide copper areas to minimize inductance and resistance.
- 5) The SC2603 is best placed over an isolated ground plane area. The soft-start capacitor, the  $V_{IN}$  decoupling capacitor, and the current sensing filter capacitor should also be connected to this ground pad area. This isolated ground area should be connected to the main ground by a trace that runs from the GND pin to the ground side of the output capacitor. If this is not possible, the GND pin may be connected to the ground path between the Output Capacitor and the  $C_{in}$ , Q1, D1 loop. Under no circumstances should GND be returned to a ground inside the  $C_{in}$ , Q1, D1 loop.
- 6) Input voltage of the SC2603 should be supplied from the power rail through a 2.2~10 $\Omega$  resistor, the  $V_{IN}$  pin should be decoupled directly to GND by a 0.1 $\mu$ F~1 $\mu$ F ceramic capacitor, trace lengths should be as short as possible.
- 7) An RC low pass filter is required to filter out leading edge current spikes on the current sensing resistor. The filter capacitor needs to be very close to the CS and GND to reduce noise pickup.

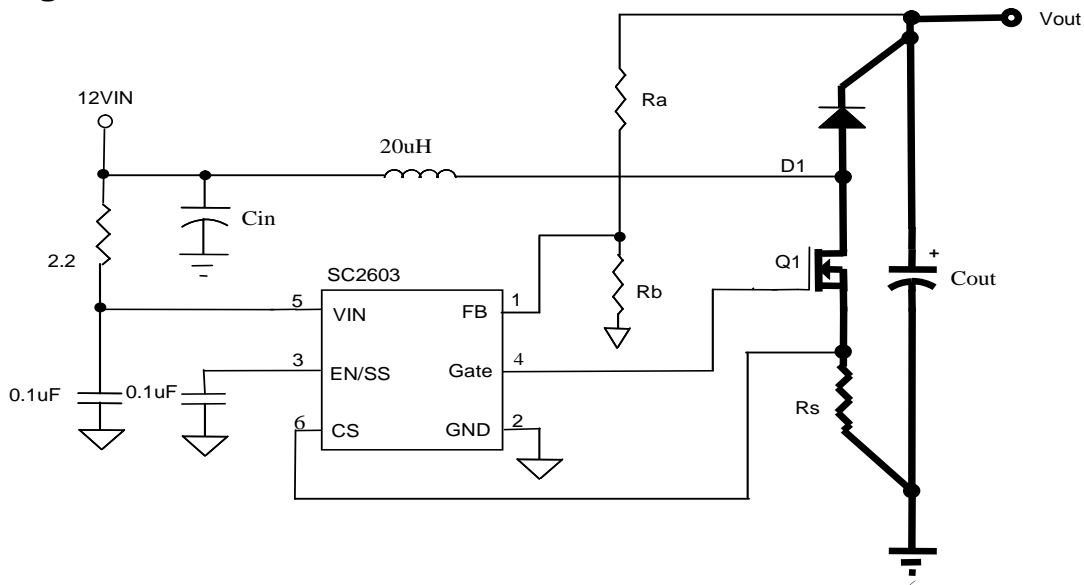
**POWER MANAGEMENT**
**Applications Information (Cont.)**
**Layout diagram for the SC2603**

Heavy lines indicate the critical loop carrying high pulsating current.  
The inductance of this loop needs to be minimized.

**POWER MANAGEMENT**

**Applications Circuit**

12V to 25V @ 1A boost converter

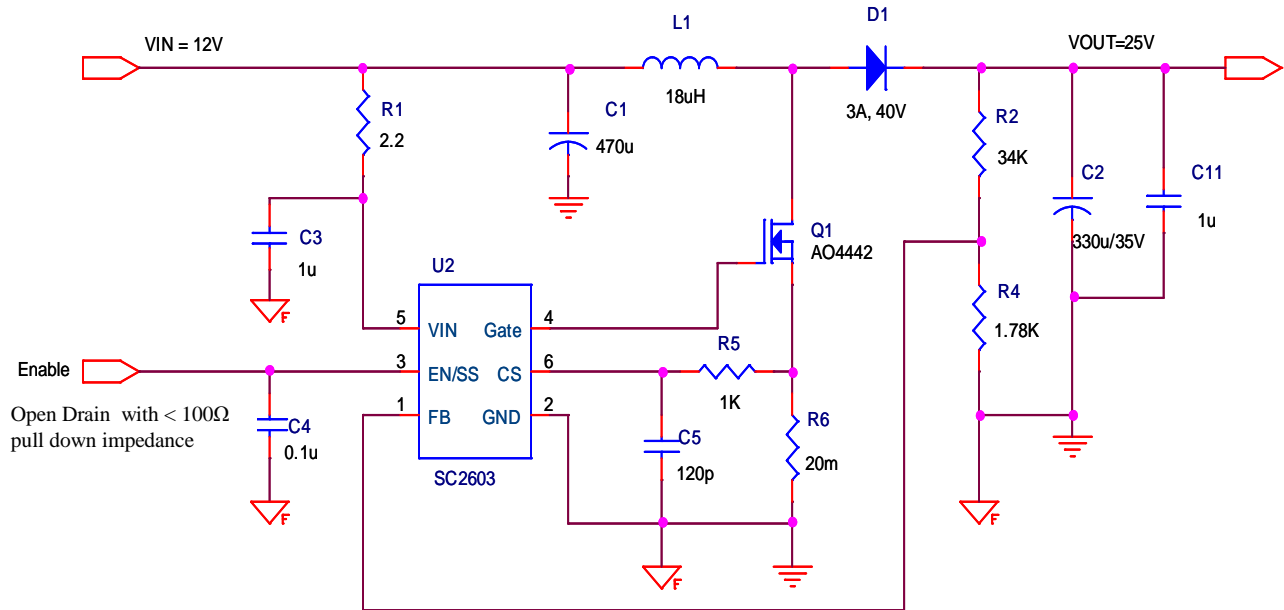

**Bill of Material**

Item	Quantity	Reference	Part	footprint	Vendor
1	1	C1	470u/Alum		SANYO
2	1	C2	330u/Alum		SANYO
3	1	C3	1uF	603	
4	1	C4	0.1u	603	
5	1	C5	120p	603	
6	1	C11	1u	805	
7	1	D1	1N5819		
8	1	L1	18uH		COOPER
9	1	Q1	AO4442		Alpha & Omega
10	1	R1	2.2	603	
11	1	R2	34K	603	
12	1	R3	0	603	
13	1	R4	1.78K	603	
14	1	R5	1K	603	
15	1	R6	20m		
16	1	U1	SC2603	SOT23-6	SEMTECH

POWER MANAGEMENT

Typical Characteristics

Error Amplifier: Gain and Phase

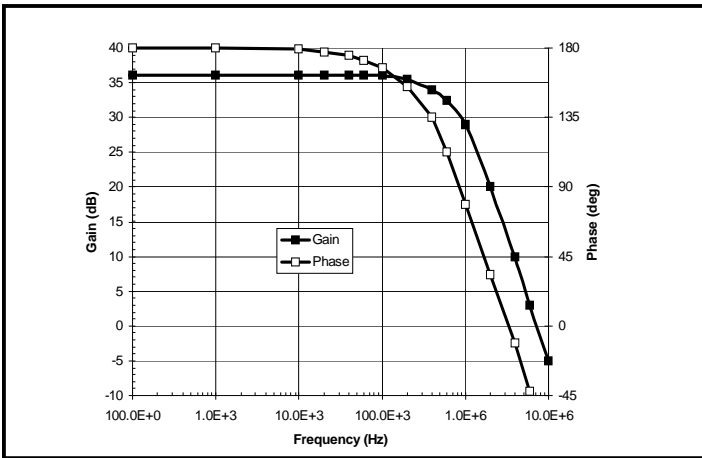

Load Regulation ( $V_{IN} = 12V, V_O = 25V$ )

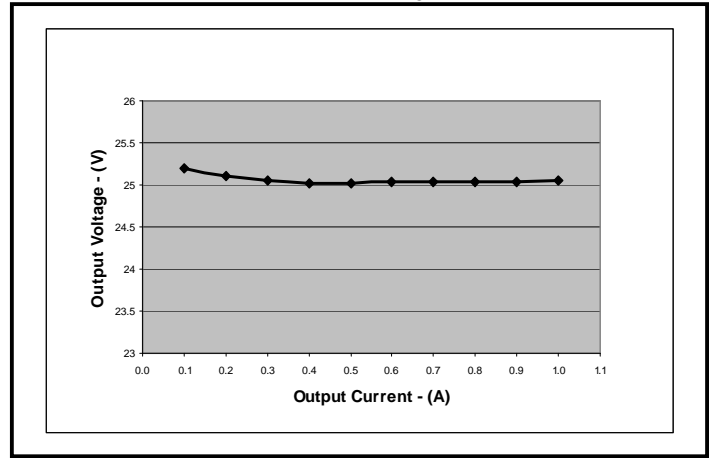

Efficiency ( $V_{IN} = 12V, V_O = 25V$ )

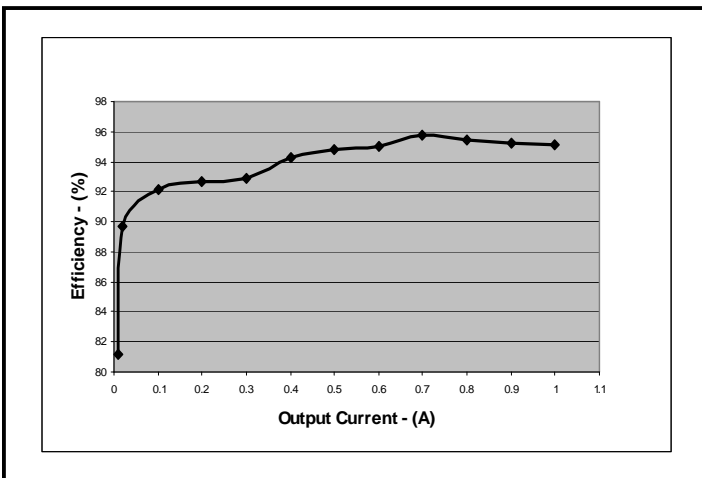

Line Regulation ( $V_O = 25V, I_O = 1A$ )

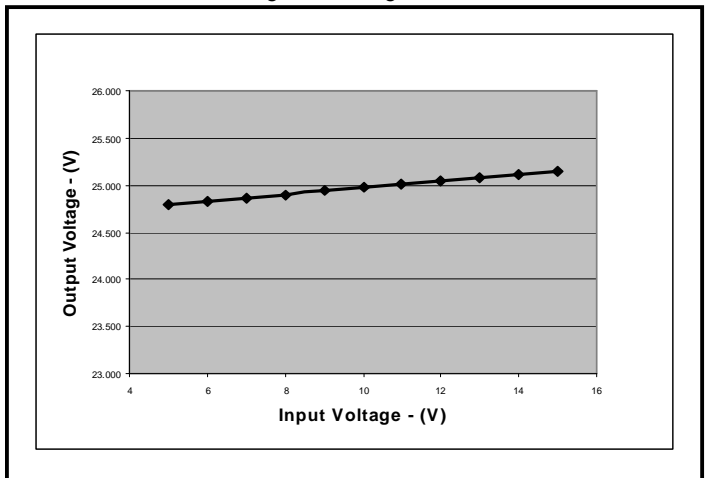

OCP ( $V_{IN} = 12V, V_O = 25V$ )

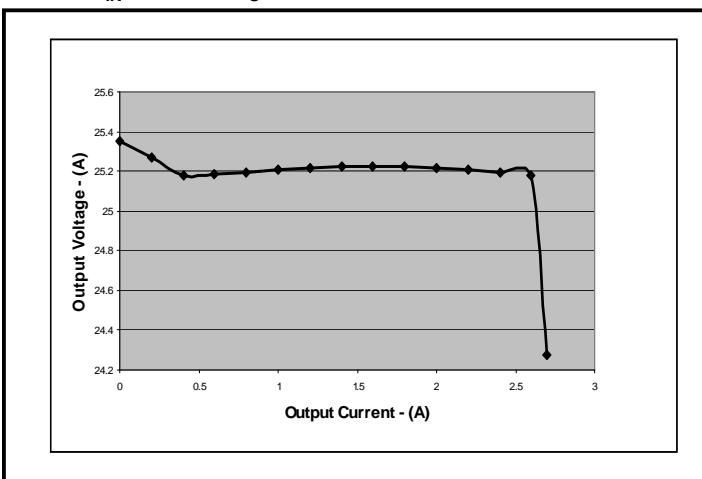

Frequency Shift ( $V_{FB}$  vs.  $F_{SW}$ )

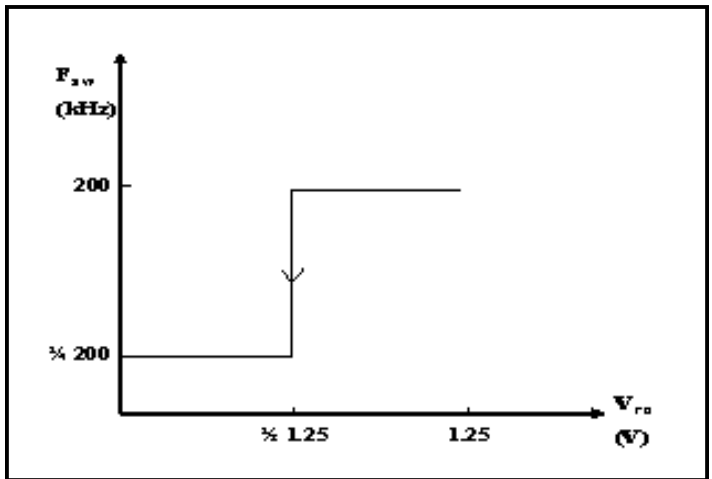



**POWER MANAGEMENT**

**Typical Characteristics**

**Reference Voltage vs Temperature**

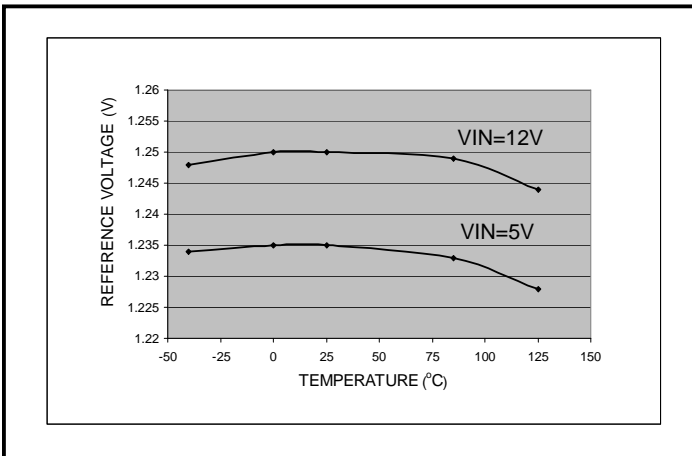

**UVLO Hysteresis vs Temperature**

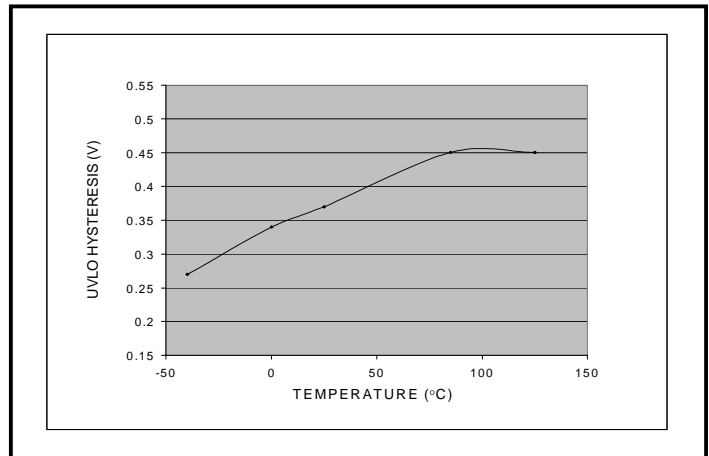

**Oscillator Frequency vs Temperature**

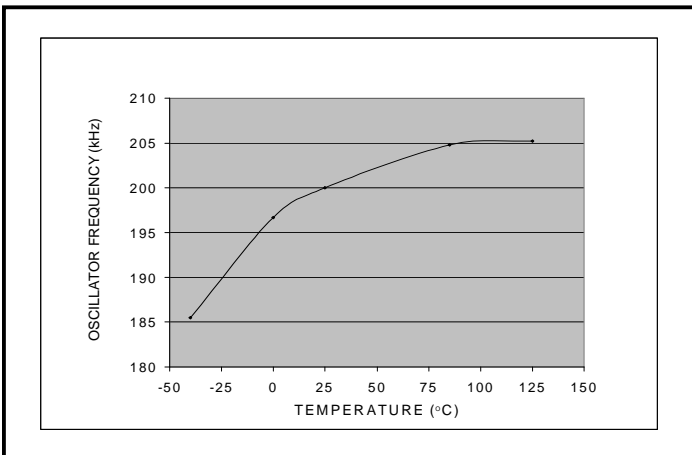

**Current Limit Threshold vs Temperature**

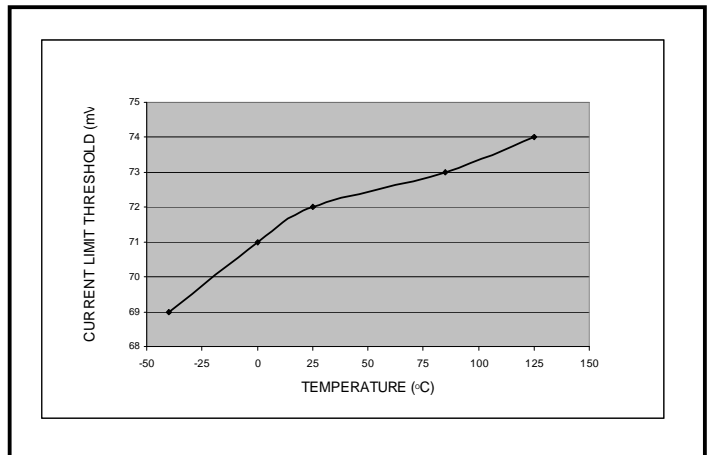

**UVLO Threshold vs Temperature**

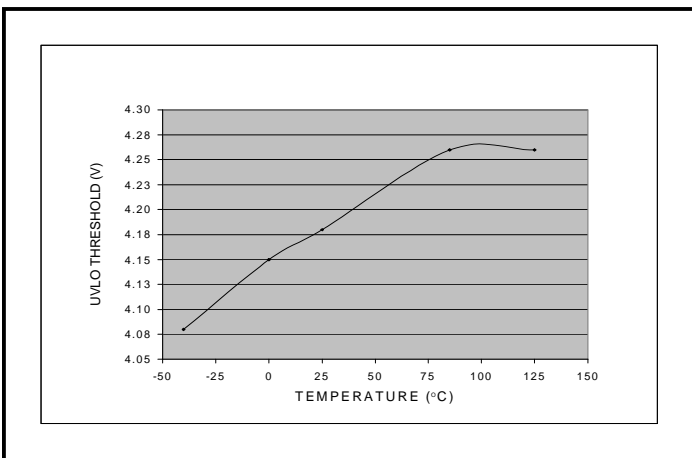

POWER MANAGEMENT

Outline Drawing - SOT23-6

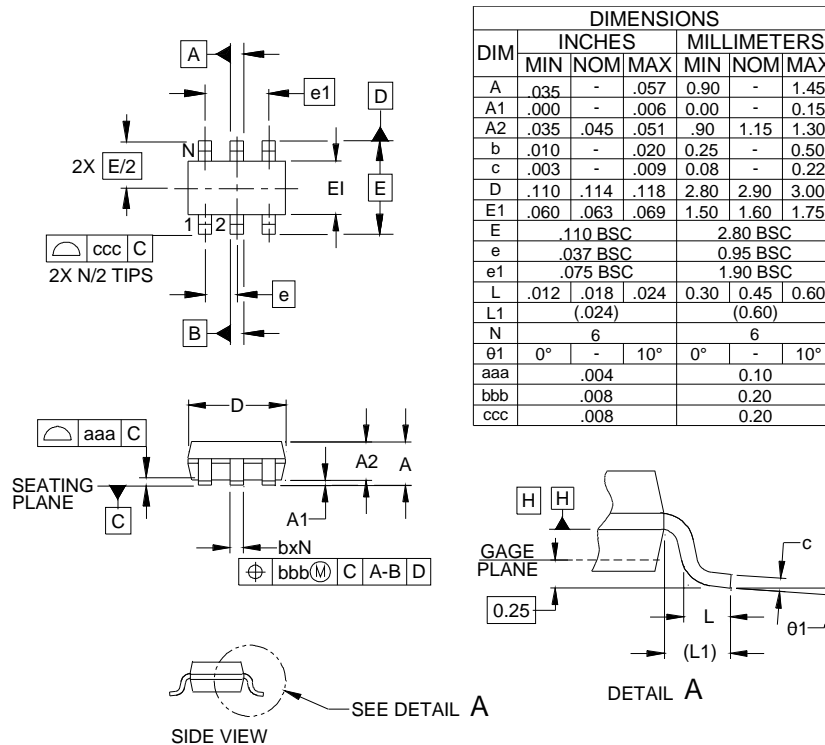

- NOTES:
1. CONTROLLING DIMENSIONS ARE IN MILLIMETERS (ANGLES IN DEGREES).
  2. DATUMS **-A-** AND **-B-** TO BE DETERMINED AT DATUM PLANE **-H-**
  3. DIMENSIONS "E1" AND "D" DO NOT INCLUDE MOLD FLASH, PROTRUSIONS OR GATE BURRS.

Land Pattern - SOT23-6

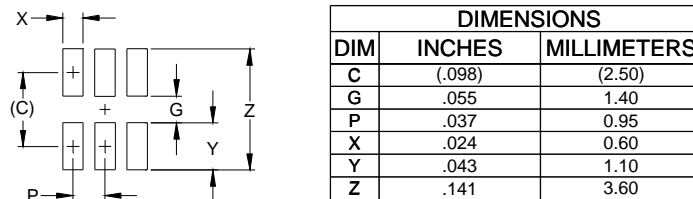

- NOTES:
1. THIS LAND PATTERN IS FOR REFERENCE PURPOSES ONLY. CONSULT YOUR MANUFACTURING GROUP TO ENSURE YOUR COMPANY'S MANUFACTURING GUIDELINES ARE MET.

Contact Information

Semtech Corporation  
 Power Management Products Division  
 200 Flynn Road, Camarillo, CA 93012  
 Phone: (805)498-2111 FAX (805)498-3804

# Mouser Electronics

Authorized Distributor

Click to View Pricing, Inventory, Delivery & Lifecycle Information:

[Semtech:](#)

[SC2603ASKTRT](#) [SC2603SKTRT](#)