

Jun.1.2019 Copyright 2019 HIROSE ELECTRIC CO., LTD. All Rights Reserved.  
 In case of consideration for using Automotive equipment / device which demand high reliability, kindly contact our sales window correspondents.

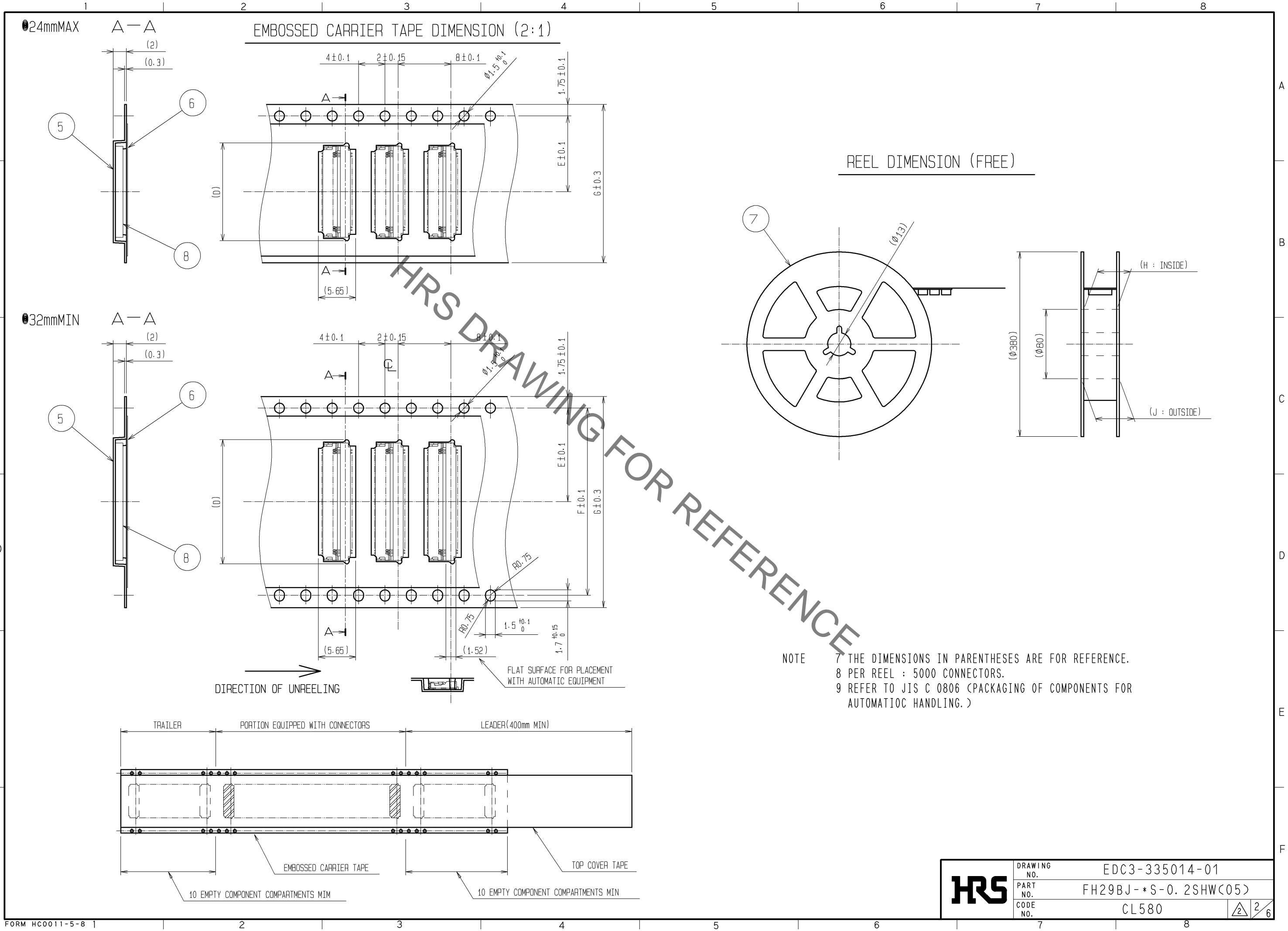

<b>HRS</b>	DRAWING NO.	EDC3-335014-01
	PART NO.	FH29BJ-*S-0.2SHW(C05)
	CODE NO.	CL580
		2/6

Jun.1.2019 Copyright 2019 HIROSE ELECTRIC CO., LTD. All Rights Reserved.  
 In case of consideration for using Automotive equipment / device which demand high reliability, kindly contact our sales window correspondents.

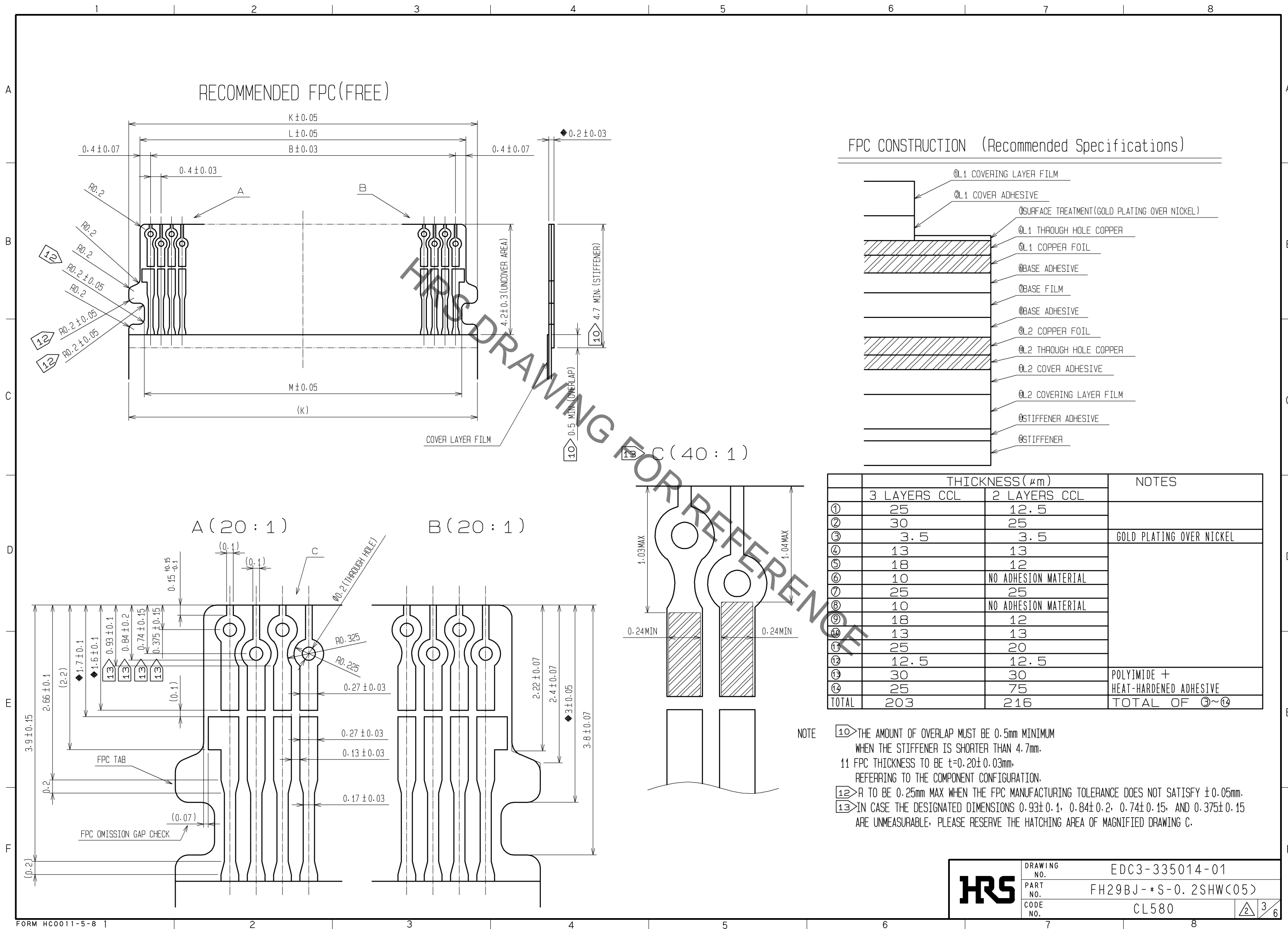

<b>HRS</b>	DRAWING NO.	EDC3-335014-01
	PART NO.	FH29BJ-*S-0.2SHW(05)
	CODE NO.	CL580
		3/6

Jun.1.2019 Copyright 2019 HIROSE ELECTRIC CO., LTD. All Rights Reserved.  
 In case of consideration for using Automotive equipment / device which demand high reliability, kindly contact our sales window correspondents.

HRS DRAWING FOR PRELIMINARY

PART NUMBER	CL NUMBER	NUMBER OF CONTACT	DIMENSION OF CONNECTOR, PATTERN, AND METAL MASK				DIMENSION OF DRAWING FOR PACKING						DIMENSION OF RECOMMENDED FPC		
			A	B	C	n	D	E	F	G	H	J	K	L	M
FH29BJ-22S-0.2SHW(05)	UNDER CONSIDERATION	22	8.22	4	4.84	11	7.22	7.5	-	16	17.4	21.4	5.66	4.8	4.47
FH29BJ-24S-0.2SHW(05)	UNDER CONSIDERATION	24	6.62	4.4	5.24	12	7.62	11.5	-	24	25.4	29.4	6.06	5.2	4.87
△ FH29BJ-34S-0.2SHW(05)	CL580-0331-7-05	34	8.62	6.4	7.24	17	9.62	11.5	-	24	25.4	29.4	8.06	7.2	6.87
FH29BJ-40S-0.2SHW(05)	UNDER CONSIDERATION	40	9.82	7.6	8.44	20	10.82	11.5	-	24	25.4	29.4	9.26	8.4	8.07
FH29BJ-44S-0.2SHW(05)	UNDER CONSIDERATION	44	10.62	8.4	9.24	22	11.62	11.5	-	24	25.4	29.4	10.06	9.2	8.87
FH29BJ-50S-0.2SHW(05)	UNDER CONSIDERATION	50	11.82	9.6	10.44	25	12.82	11.5	-	24	25.4	29.4	11.26	10.4	10.07
FH29BJ-60S-0.2SHW(05)	CL580-0330-4-05	60	13.82	11.6	12.44	30	14.82	11.5	-	24	25.4	29.4	13.26	12.4	12.07
FH29BJ-70S-0.2SHW(05)	CL580-0327-0-05	70	15.82	13.6	14.44	35	16.82	11.5	-	24	25.4	29.4	15.26	14.4	14.07
△ FH29BJ-80S-0.2SHW(05)	CL580-0329-5-05	80	17.82	15.6	16.44	40	18.82	14.2	28.4	32	33.4	37.4	17.26	16.4	16.07
△ FH29BJ-90S-0.2SHW(05)	CL580-0334-5-05	90	19.82	17.6	18.44	45	20.82	20.2	40.4	44	45.4	49.4	19.26	18.4	18.07
FH29BJ-100S-0.2SHW(05)	UNDER CONSIDERATION	100	21.82	19.6	20.44	50	22.82	20.2	40.4	44	45.4	49.4	21.26	20.4	20.07
△ FH29BJ-120S-0.2SHW(05)	CL580-0328-2-05	120	25.82	23.6	24.44	60	26.82	20.2	40.4	44	45.4	49.4	25.26	24.4	24.07

HRS	DRAWING NO.	EDC3-335014-01	
	PART NO.	FH29BJ-*S-0.2SHW(05)	
	CODE NO.	CL580	△ 4/6

In case of consideration for using Automotive equipment / device which demand high reliability, kindly contact our sales window correspondents.

[INSTRUCTIONS ON INSERTING FPC AND CONNECTION]

This connector is small and thin and requires delicate and careful handling. Read through the instructions shown below and handle the connector properly. Each values indicating here are for reference and may differ from standard value.

[INSTRUCTIONS FOR MOUNTING ON THE BOARD]

◆Warp of Board

Minimize warp of the board as much as possible.  
Lead co-planarity is 0.1 mm or less.  
Too much warp of the board may result in a soldering failure.

◆Load to Connector

Do not apply a force of 0.5 N or more to the connector before mounting it on the board. Otherwise, the connector may be broken.  
Do not insert the FPC or operate the connector before mounting it.

◆Load to Board

·Splitting a large board into several pieces  
·Screwing the board  
Avoid the handling described above so that no force is exerted on the board during the assembly process. Otherwise, the connector may become defective.

◆Amount of Warp

The warp of a 100-mm wide board should be 0.5 mm or less.  
The warp of board suffers stress on connector and the connector may become defective.

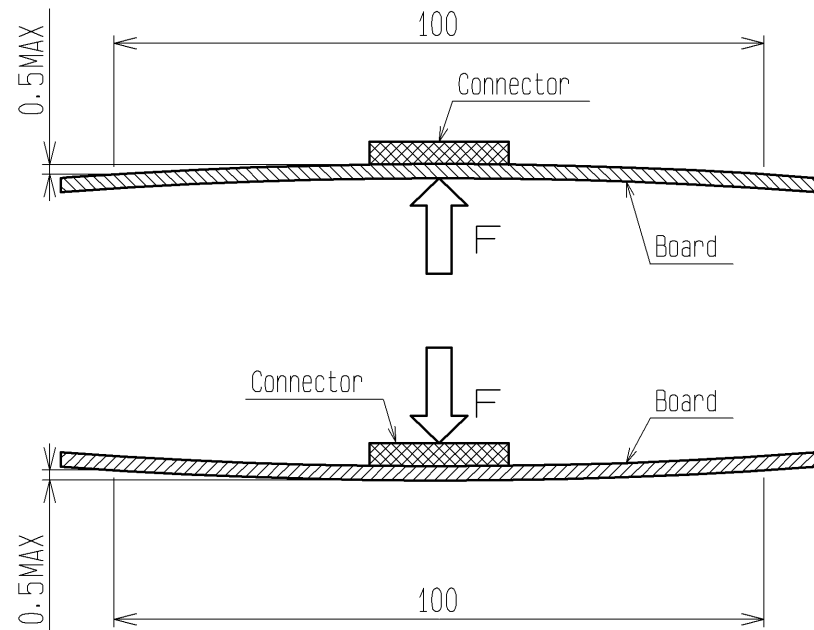

◆ Use of the Actuator

1. Be very careful not to apply excessive force when releasing the actuator in the initial position (with no FPC inserted).  
If you use your nail or finger as shown below, the terminals may be deformed.

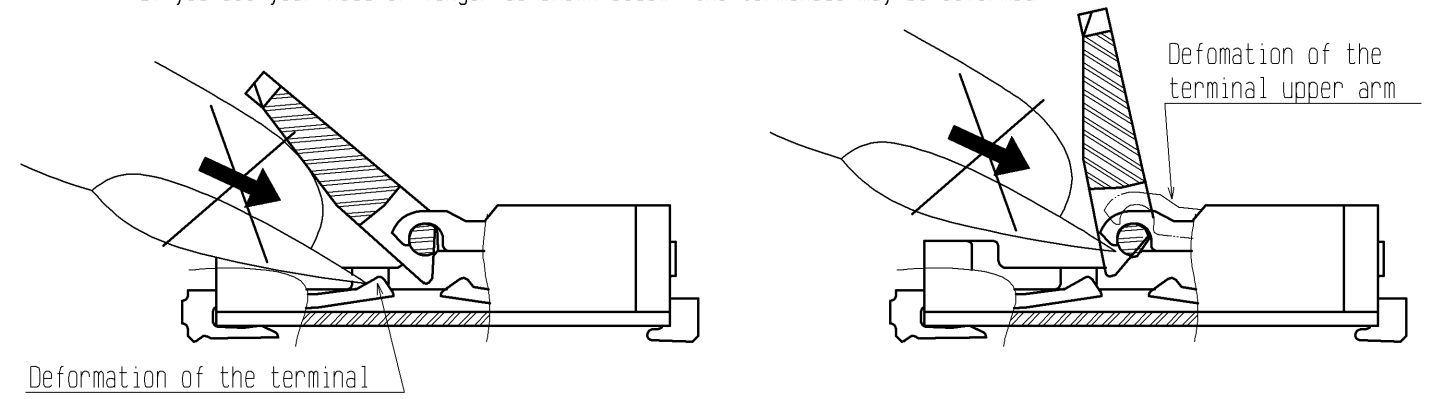

Example 1

Example 2

2. The actuator rotates around the rotational axis as shown below. Rotate the actuator.

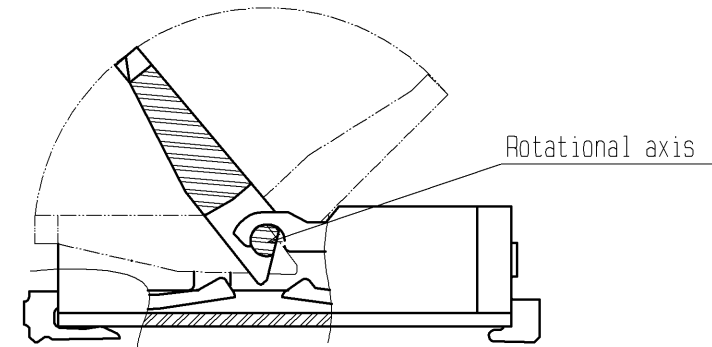

3. Please do not push downwards to the actuator with more than 0.5N force, as shown below. Otherwise, the actuator may fall off or be damaged.

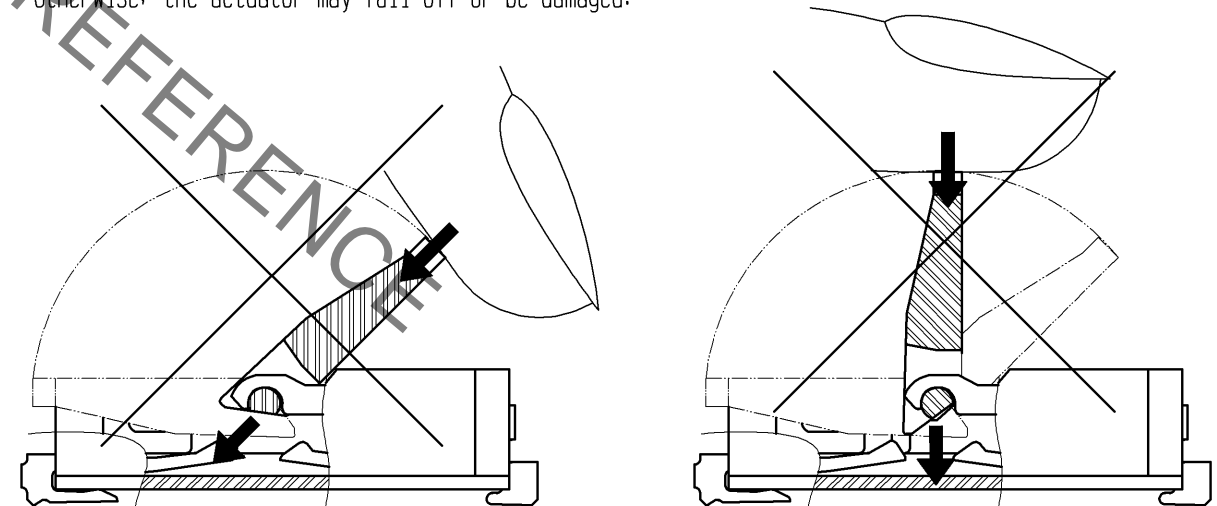

4. The actuator will not open more than 135°.

Do not apply any force backward beyond this point. Otherwise, the actuator may come off or break.

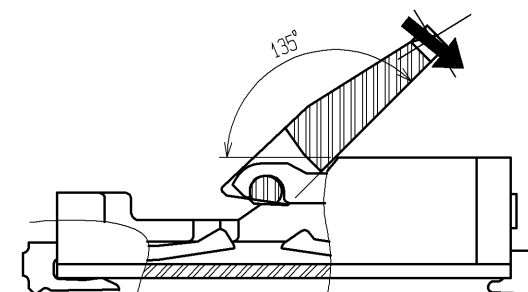

<b>HRS</b>	DRAWING NO.	EDC3-335014-01
	PART NO.	FH29BJ-*S-0.2SHW<05>
	CODE NO.	CL580
		5/6

Jun.1.2019 Copyright 2019 HIROSE ELECTRIC CO., LTD. All Rights Reserved.  
In case of consideration for using Automotive equipment / device which demand high reliability, kindly contact our sales window correspondents.

- 5. Move the actuator at approximately the center.  
(It may break if operate the edge of the actuator with FPC inserted.)
- 6. Do not pinch or pick the actuator to lift it as shown below. Otherwise, it may break.  
(Do not carry out any operation other than rotating the actuator as shown in 2 above.)

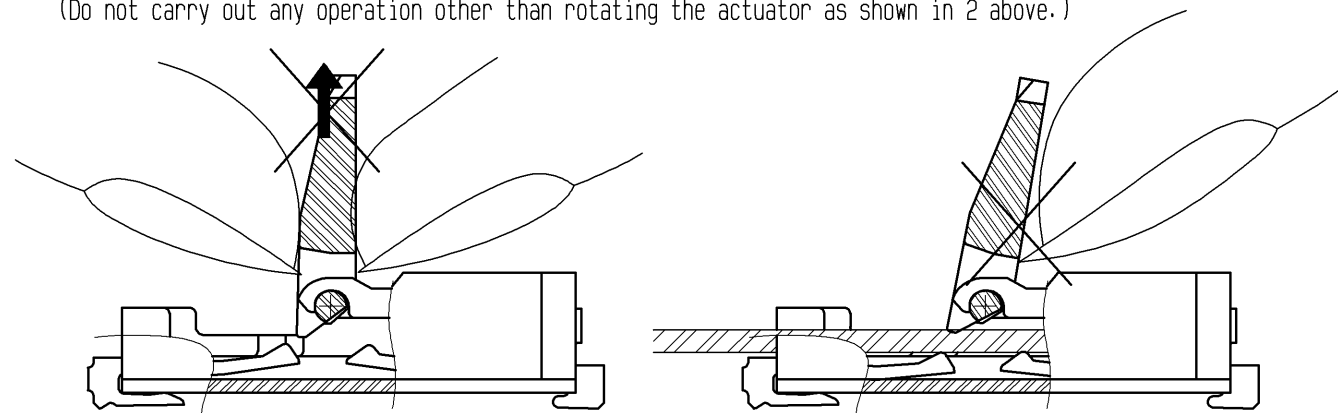

◆Direction of Contacts

This connector has contacts on the bottom. Thus, insert the FPC with the exposed conductors face down.

◆Inserting the FPC

1. Insert the FPC by about 10 degrees along the surface and at a right angle to the connector.  
Insert it properly to the very end.  
If the FPC is inserted at a slant (incorrectly),  
the conductors may short-circuit due to pitch shift or the edge of the FPC may catch in the terminals,  
resulting in deformation of the terminals.

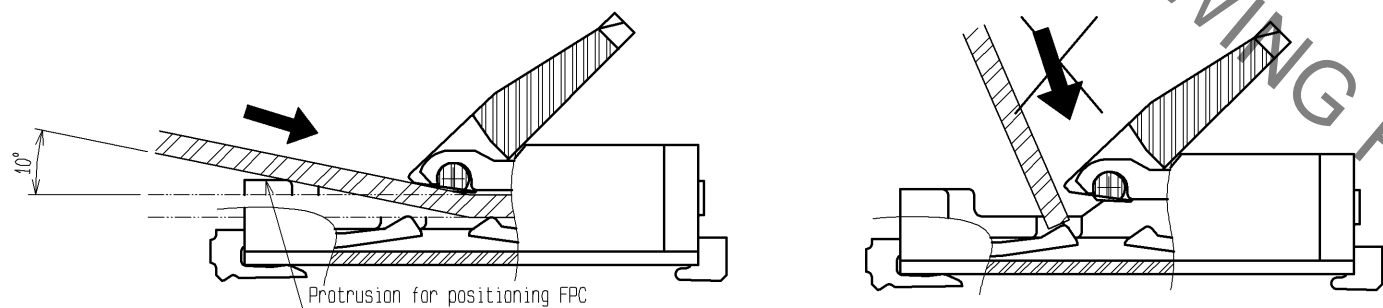

2. Do not insert the FPC diagonally from above.  
If the FPC is inserted at a slant (incorrectly) as shown below in the FPC insertion process,  
the FPC may bend and patterns may break or the FPC may not insert completely,  
resulting in improper conduction.

※Keep a sufficient FPC insertion space in the stage of the layout in order to avoid incorrect FPC insertion.  
Besides, it is not difficult to insert FPC correctly all the way to the end.  
Design the proper layout of parts.

※Make adjustments with the FPC manufacturer for FPC bending performance and wire breakage.

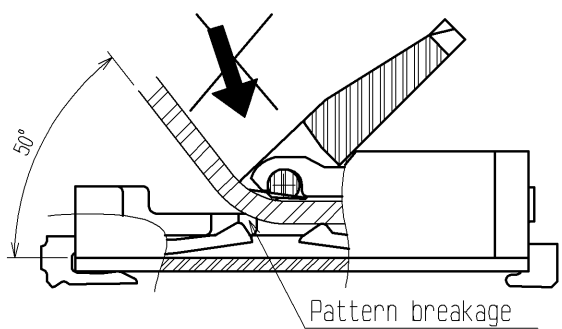

◆Checking the Locking Condition

In the locked condition, make sure that the actuator is horizontal on the board surface.  
Do not apply excessive force to it near the 0° position of the actuator.  
Otherwise, the terminals may be deformed. (Allowable force: 1 N or less)

[INSTRUCTIONS ON FPC LAYOUT AFTER CONNECTION]

◆Load to FPC

Be very careful not to apply any force to the FPC after inserting it.  
Otherwise, the connector may become unlocked or the FPC may break.  
Fix the FPC, in particular, when loads are applied to it continuously.  
Design the FPC layout with care not to bend it sharply near the insertion opening.

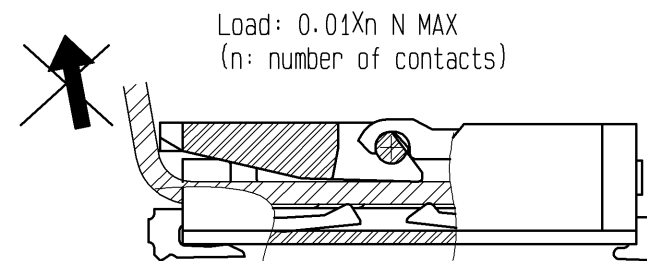

[INSTRUCTIONS ON REMOVING FPC]

- ◆Release the actuator at approximately the center.  
(It may break if operate the edge of the actuator with FPC inserted.)
- ◆Release the actuator to remove the FPC.  
Remove the FPC by about 10 degrees along the surface.

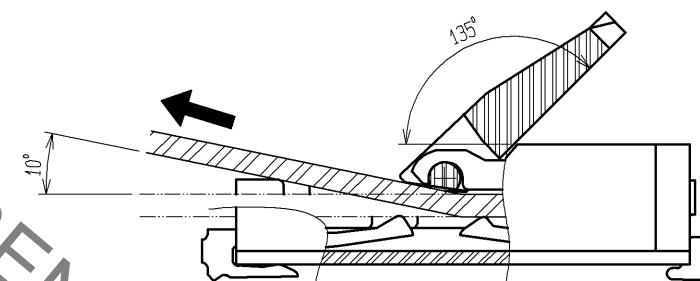

[OTHER INSTRUCTIONS]

◆Instructions on Manual Soldering

- Follow the instructions shown below when soldering the connector manually during repair work, etc.
1. Do not perform reflow soldering or manual soldering with the FPC inserted into the connector.
  2. Do not heat the connector excessively. Be very careful not to let the soldering iron contact any parts other than connector leads. Otherwise, the connector may be deformed or melt.
  3. Do not use excessive solder (or flux).  
If excessive solder (or flux) is used on the terminals, solder or flux may adhere to the contacts or rotating parts of the actuator, resulting in poor contact or a rotation failure of the actuator.

<b>HRS</b>	DRAWING NO.	EDC3-335014-01
	PART NO.	FH29BJ-*S-0.2SHW<05>
	CODE NO.	CL580
		6/6

# Mouser Electronics

Authorized Distributor

Click to View Pricing, Inventory, Delivery & Lifecycle Information:

## [Hirose Electric:](#)

[FH29BJ-90S-0.2SHW\(05\)](#) [FH29BJ-60S-0.2SHW\(05\)](#) [FH29BJ-80S-0.2SHW\(05\)](#) [FH29BJ-70S-0.2SHW\(05\)](#) [FH29BJ-120S-0.2SHW\(05\)](#)