

Table CE1 – Maximum Ratings

Part Number	IEC61000-4-2, level 4 (ESD Withstand)		Temperature	
	Contact (kV)	Air (kV)	Operating (°C)	Storage (°C)
SESD0201P1BN-0400-090	±10*	±16	-40 to +125	-40 to +125
SESD0402P1BN-0450-090	±10*	±16	-40 to +125	-40 to +125

Table CE2 – Electrical Characteristics @ T=25°C

Part Number	Input Capacitance*		Leakage Current (max) I _L @ V _{RWM} = 6.0V (µA)	Breakdown Voltage (min) V _{br} @ I _T [†] = 1mA (V)	Working Reverse Voltage V _{RWM} @ peak (V)	Clamping Voltage (typ) V _{CL} @ I _{pp} =2A, tp=(8/20µs) (V)*
	Typ (pF)	Max (pF)				
SESD0201P1BN-0400-090	4.0	5.0	1.0	9.0	6.0	+10.0
SESD0402P1BN-0450-090	4.5	5.5	1.0	9.0	6.0	+10.0

* @ Vr=0V, f=1MHz

† V_{br} is measured at test current I_T

Figure CE1 – ESD Clamping Voltage - 8kV Contact

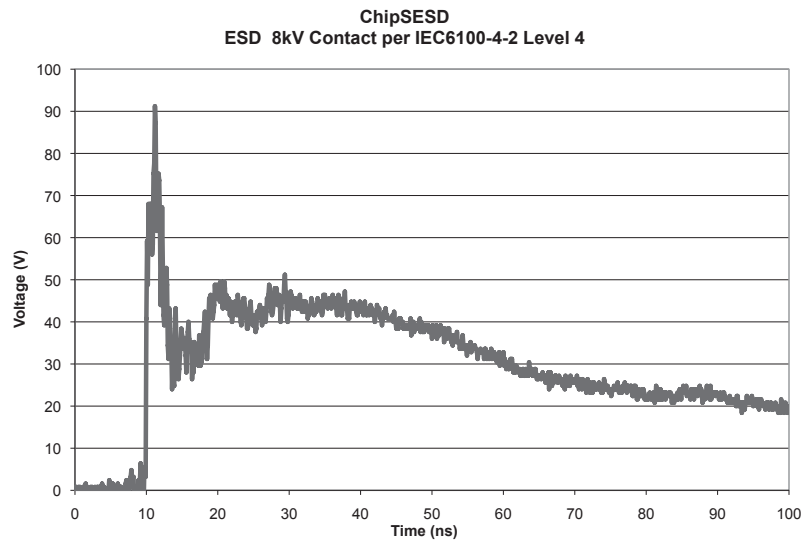
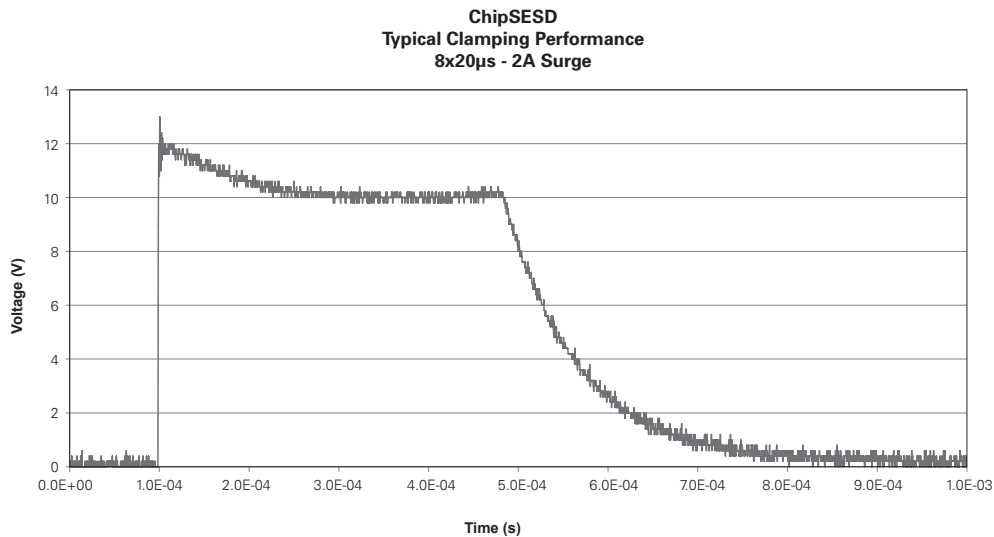

Figure CE2 – ESD Clamping Voltage - 8x20µs, 2A Surge



ChipSESD Devices

Table CE3 - Dimensions in Millimeters and (Mils)*

Part Number	A	B	C	D	Figure
SESD0201P	0.60 ± 0.05	0.30 ± 0.05	0.30 ± 0.05	0.21 ± 0.07	CE3
	(23.62 ± 2.00)	(11.81 ± 2.00)	(11.81 ± 2.00)	(8.27 ± 2.80)	
SESD0402P	1.10 ± 0.10	0.50 ± 0.10	0.50 ± 0.10	0.25 ± 0.15	CE3
	(43.31 ± 0.40)	(19.69 ± 4.00)	(19.69 ± 4.00)	(9.84 ± 6.00)	

* Round off approximation

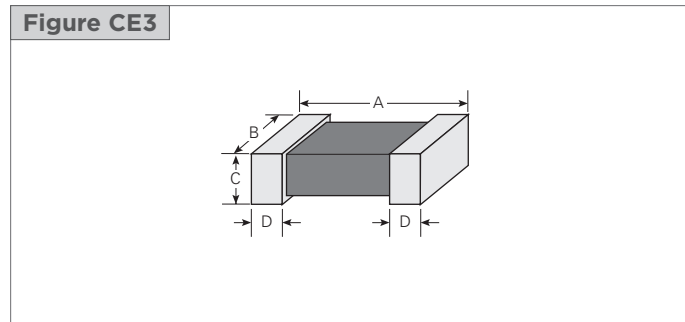

Table CE4 - PCB Pad Layout in Millimeters and (Mils)*

Part Number	L	S	W	Figure
SESD0201P	0.28 ± 0.01	0.19 ± 0.01	0.30 ± 0.01	CE4
	(11.00 ± 0.40)	(7.50 ± 0.40)	(11.80 ± 0.40)	
SESD0402P	0.61 ± 0.05	0.52 ± 0.05	0.50 ± 0.05	CE4
	(24.00 ± 2.00)	(21.00 ± 2.00)	(20.00 ± 2.00)	

* Round off approximation

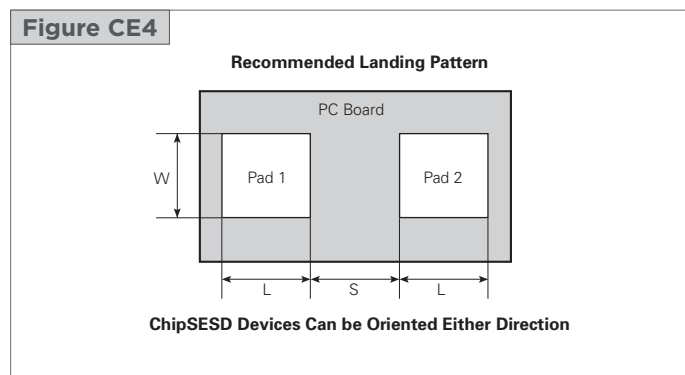

Table CE5 – Tape Specifications

Tape Dimension EIA Mark	SESD0201P1BN-0400-090	SESD0402P1BN-0450-090
	Dimension (mm)	Dimension (mm)
A	0.35 ± 0.02	0.58 ± 0.03
B	0.67 ± 0.02	1.20 ± 0.03
D	1.55 ± 0.05	1.55 ± 0.05
E	1.75 ± 0.05	1.75 ± 0.05
F	3.50 ± 0.05	3.50 ± 0.05
W	8.00 ± 0.10	8.00 ± 0.10
P ₀	4.00 ± 0.10	4.00 ± 0.10
P ₁	2.00 ± 0.05	2.00 ± 0.05
P ₂	2.00 ± 0.05	2.00 ± 0.05
T	0.42 ± 0.03	0.60 ± 0.03

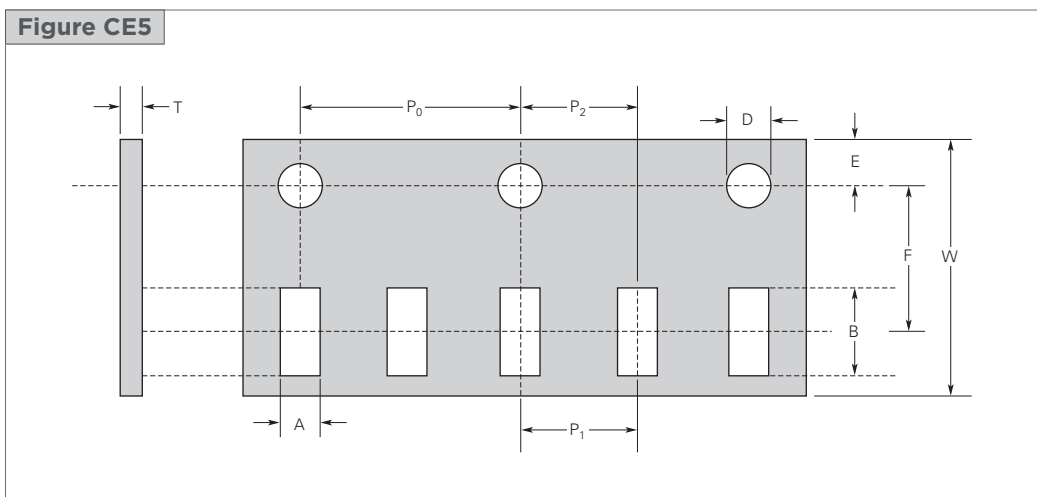
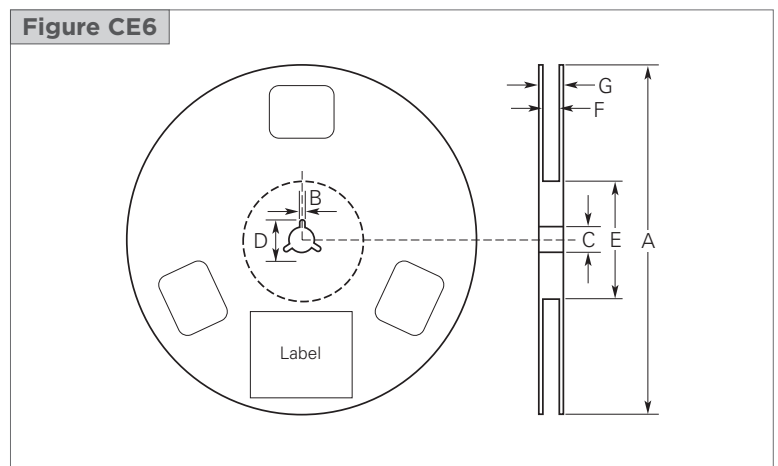

Table CE6 – Reel Specifications

Reel Dimension EIA Mark	Dimension (mm)
A	178.0 ± 2.0
B	2.0 ± 0.5
C	13.0 ± 0.5
D	21.0 ± 0.8
E	62.0 ± 1.5
F	9.0 ± 0.5
G	13.0 ± 1.0



ChipSESD Devices

Definition of Terms

I_L	Reverse Leakage Current @ V_{RWM}
V_{RWM}	Working Peak Reverse Voltage
V_{br}	Breakdown Voltage @ I_T
I_T	Test Current
V_{CL}	Clamping Voltage

Part Numbering System

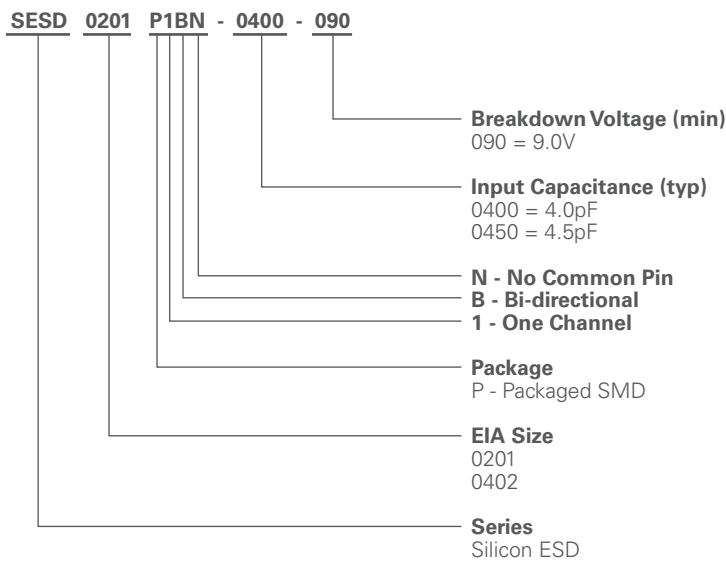

Notice:

Littelfuse products are not designed for, and shall not be used for, any purpose (including, without limitation, automotive, military, aerospace, medical, life-saving, life-sustaining or nuclear facility applications, devices intended for surgical implant into the body, or any other application in which the failure or lack of desired operation of the product may result in personal injury, death, or property damage) other than those expressly set forth in applicable Littelfuse product documentation. Warranties granted by Littelfuse shall be deemed void for products used for any purpose not expressly set forth in applicable Littelfuse documentation. Littelfuse shall not be liable for any claims or damages arising out of products used in applications not expressly intended by Littelfuse as set forth in applicable Littelfuse documentation. The sale and use of Littelfuse products is subject to Littelfuse Terms and Conditions of Sale, unless otherwise agreed by Littelfuse.

