

TYPICAL DEVICE RATINGS AND CHARACTERISTICS

	Continuous Max Operating Voltage	Typical TLP Trigger Voltage ¹	Typical TLP Clamping Voltage ¹ after 30ns	Typical Capacitance ² @ 1 MHz, 1V _{rms}	Typical Leakage Current @ 14V _{DC}	Max Leakage Current @ 14V _{DC}
Symbol	V _{DC}	V _{T(TLP)}	V _{C(TLP 30)}	C _p	I _{L(Typ)}	I _{L(MAX)}
Unit	V	V	V	pF	μA	μA
Value	14	250	40	0.25	<0.01	10.0

Note 1: TLP test method at 1000V (refer to FIG. 5 on page 5)

Note 2: Typical capacitance @ 0V and 14V bias

GENERAL CHARACTERISTICS

Operating temperature: -55°C to +125°C

Storage temperature: -55°C to +125°C

ESD voltage capability (tested per IEC 61000-4-2)

- Contact discharge mode: 8kV (typ), 15kV (max)
- Air discharge mode: 15kV (typ), 25kV (max) [1 pulse: per customer request]

ESD pulse withstand: Typically 100 pulses (tested per IEC 61000-4-2, level 4, and contact method)

Environmental Specifications

	Bias Humidity Test	Thermal Shock	Bias Heat Test	Bias Low Temp Test	Solderability	Solder Heat	Vibration	Mechanical Shock	Solvent Resistance
Test Conditions	@ 85°C @ 85% RH V _{DC} (max) 1000 hours	-55°C to 125°C 30min dwell 1000 cycles	@ 125°C V _{DC} (max) 1000 hours	@ -55°C V _{DC} (max) 1000 hours	250 °C +/- 5 °C 3s +/- 1s	260 °C, 10s	10 to 50Hz, 60s cycle, 2hrs each in X-Y-Z axis	1500G, 0.5ms, X-Y-Z axis 3 times	IPA ultrasonic 300s
Pass/Fail Criteria	I _L ≤ 10μA	I _L ≤ 10μA	I _L ≤ 10μA	I _L ≤ 10μA	95% coverage	90% coverage	No Physical Damage I _L ≤ 10 μA	No Physical Damage I _L ≤ 10 μA	No Physical Damage I _L ≤ 10 μA

FIG 1: CAPACITANCE VS. FREQUENCY (TYPICAL SAMPLE)

(PESD0402 Flat Response of Capacitance over Frequency Range)

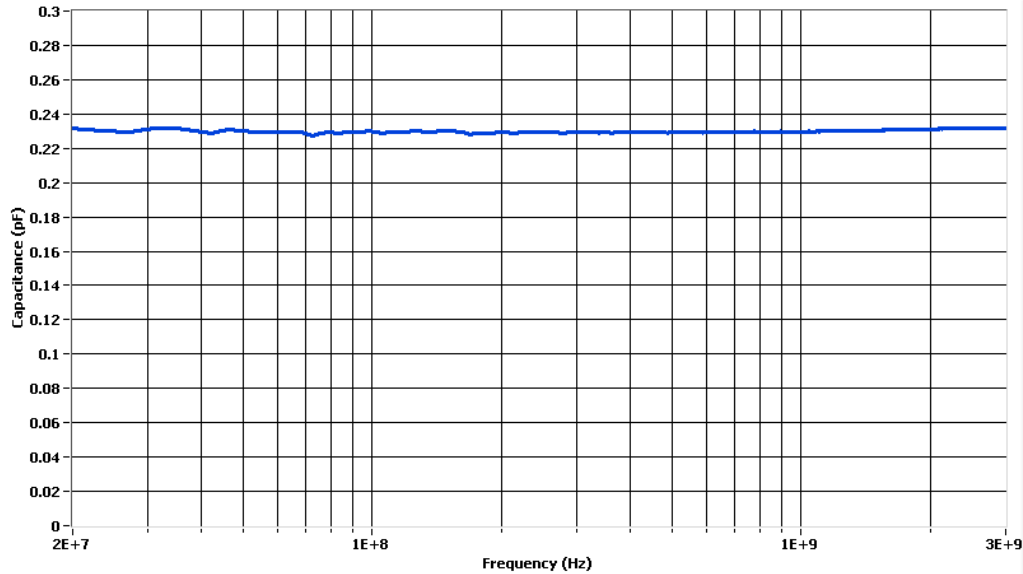

FIG 2: EYE DIAGRAM (TYPICAL SAMPLE)

(PESD0402 Eye Diagram Performance at 3.4 GHz— meets criteria for HDMI 1.3)

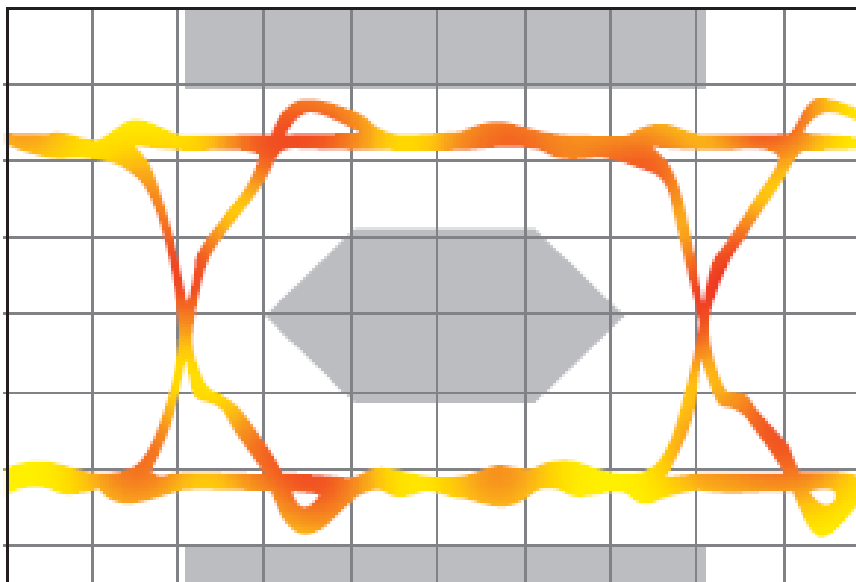

FIG 3: INSERTION LOSS DIAGRAM (TYPICAL SAMPLE)
(PESD0402 Minimal Insertion Loss at 3.4 GHz)

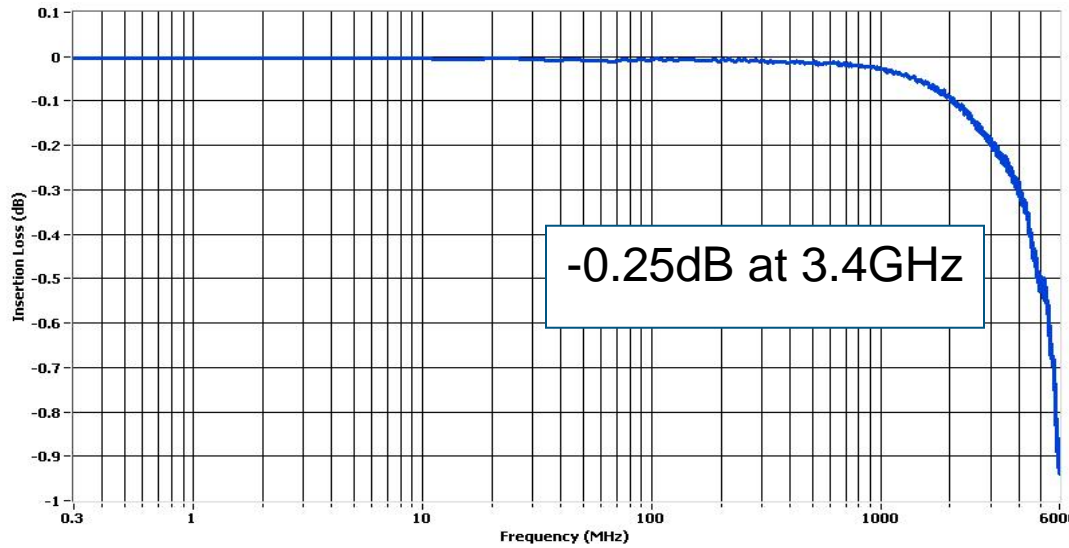

FIG 4: ESD PROTECTION FOR HDMI
(PESD0402 Reference Layout and Test Results available)

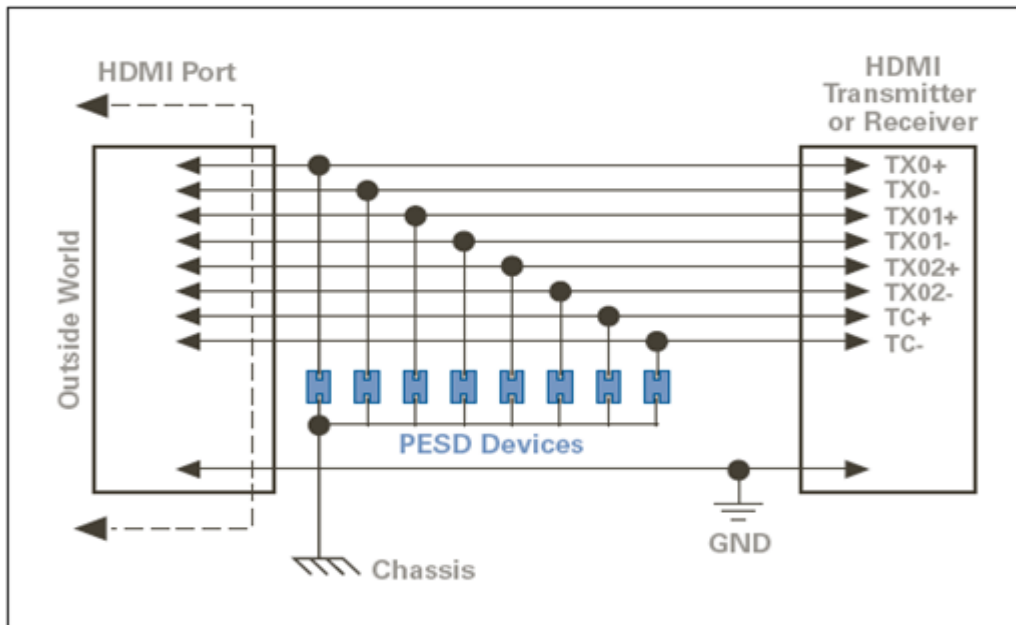
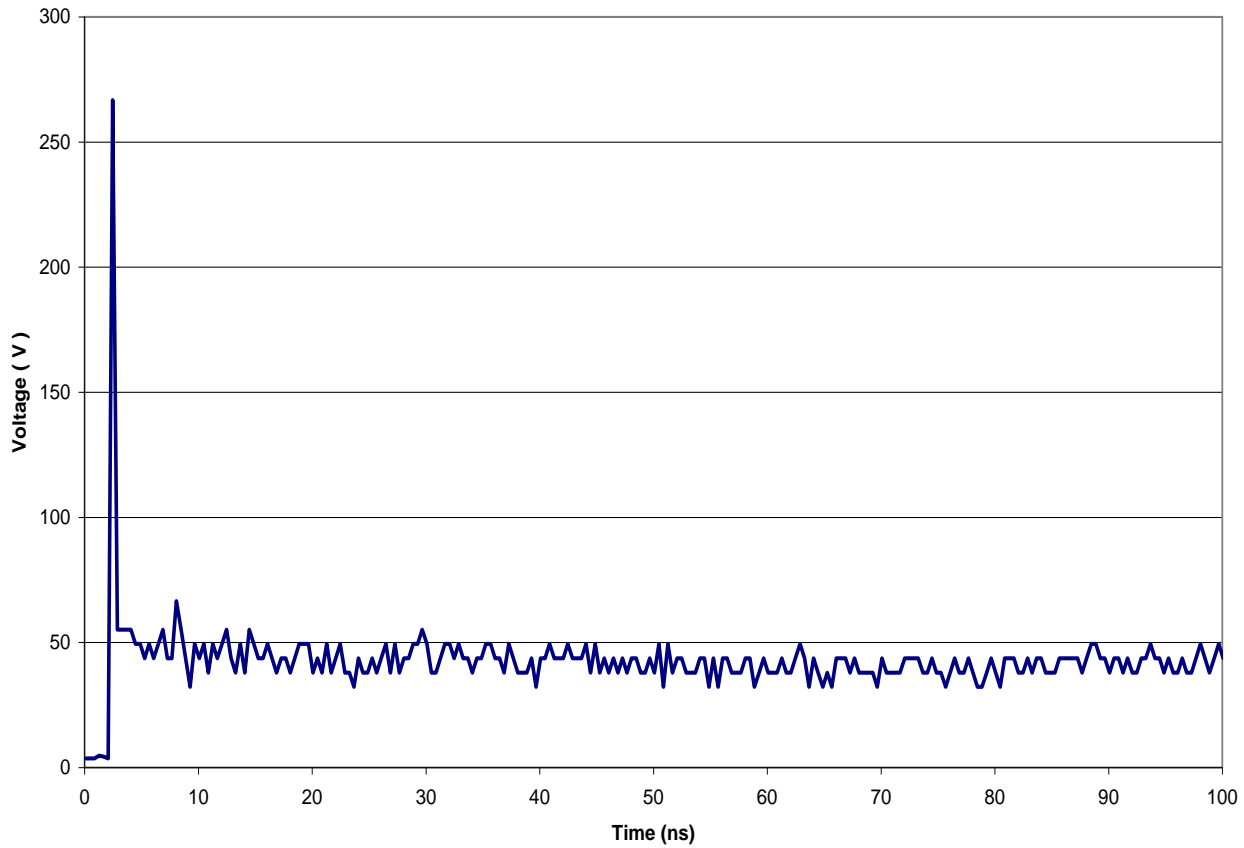
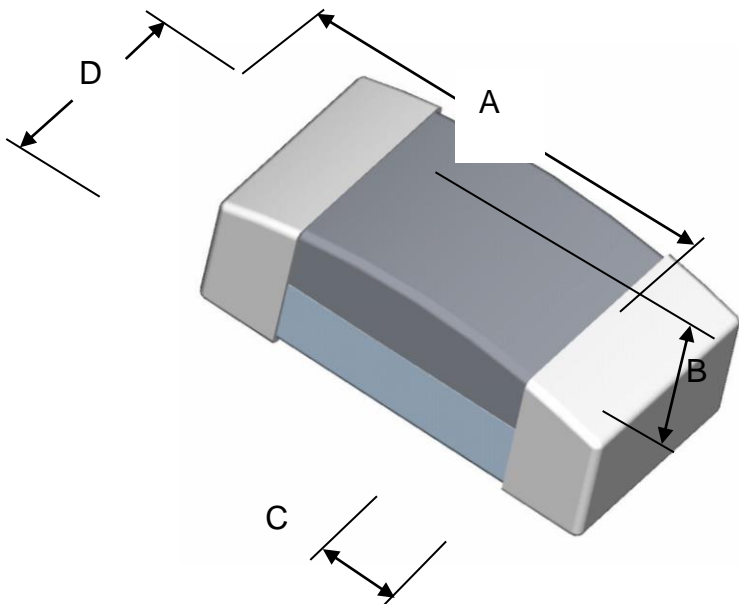

FIG 5: TYPICAL TRANSMISSION LINE PULSE RESPONSE GRAPH

Typical TLP Clamping Voltage



DIMENSIONS



Drawing Not To Scale

	Length A		Height B		Terminal Width C		Width D	
	Min	Max	Min	Max	Min	Max	Min	Max
mm	0.90	1.10	0.23	0.43	0.10	0.30	0.40	0.60
in*	(0.035)	(0.043)	(0.009)	(0.017)	(0.004)	(0.012)	(0.016)	(0.024)

* Round off approximation

RECOMMENDED LAND PATTERN:

Solder thickness 0.15 to 0.2mm

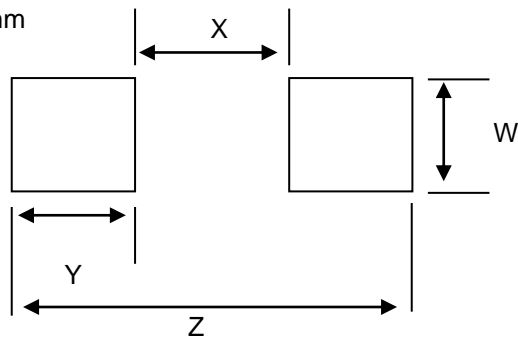

	W		X		Y		Z	
	Min	Max	Min	Max	Min	Max	Min	Max
mm	0.60	0.70	0.30	0.40	0.80	0.90	2.10	2.20
in*	(0.024)	(0.028)	(0.012)	(0.016)	(0.031)	(0.035)	(0.083)	(0.087)

* Round off approximation

SOLDER REFLOW RECOMMENDATIONS:

A	Temperature ramp up 1	From ambient to Preheating temperature	30s to 60s
B	Preheating	140°C - 160°C	60s to 120s
C	Temperature ramp up 2	From Preheating to Main heating temperature	20s to 40s
D	Main heating	at 200°C at 220°C at 240°C at 260°C	60s ~ 70s 50s ~ 60s 30s ~ 40s 5s ~ 10s
E	Cooling	From main heating temperature to 100°C	4°C/s (max)

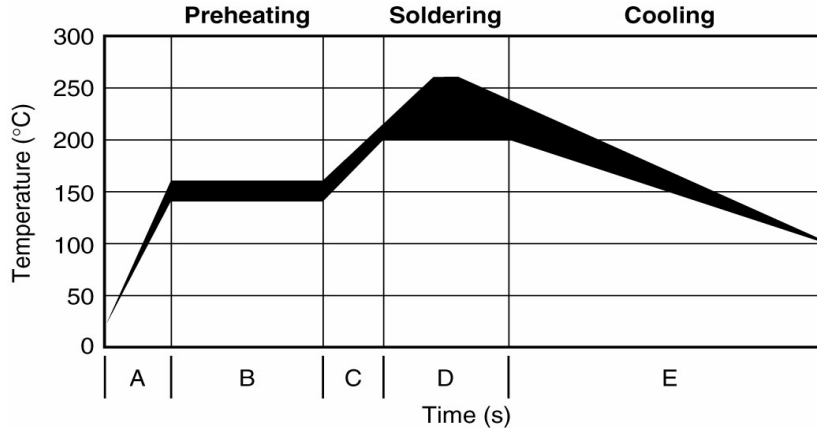

PACKAGING

Packaging	Tape & Reel	Standard Box
PESD0402-140	10,000	50,000

EIA referenced Reel Dimensions for PESD Devices

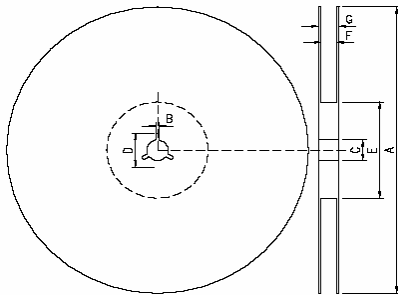

Reel Dimensions (mm):

	A	B	C	D	E	F	G
0402 Devices	178.0 ±2.0	2.0 ±0.5	13.0 ±0.5	21.0 ±0.8	62.0 ±1.5	9.0 ±0.5	13.0 ±1.0

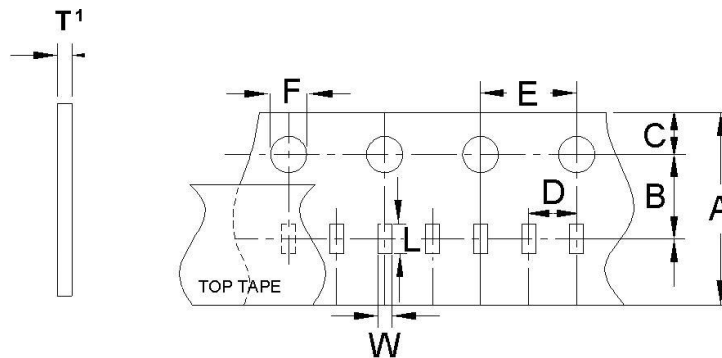

Carrier

Dimensions (mm):

	A	B	C	D	E	F	L	W	T ¹
0402 Devices	8.00 ±0.30	3.50 ±0.05	1.75 ±0.10	2.00 ±0.05	4.00 ±0.10	1.50 ±0.10	1.13 ±0.03	0.63 ±0.03	0.48 ±0.03

Note 1: Carrier thickness

Product Orientation – always face up (meaning the substrate is at the bottom), but parts do not have polarity mark.

Leader & Trailer: The leader is 180mm in length & consists of empty cavities with sealed cover tape. The trailer is 350mm in length & consists of empty cavities with sealed cover tape.

POST REFLOW, CLEANING CONDITIONS

A 5% saponifier combined with water during wash.

For the ultrasonic process water temperature should be at 50°C and board should be submerged for a minimum of one minute in the solutions, then rinse and dry.

For in-line washing, the temperature of the water sprayed should be at 110°C, rinse and drying is done in-line.



Warning: Application Limitations for PESD0402-140. This part is not intended to be used on power lines or for power bus applications. Users should independently evaluate the suitability of and test each product selected for their own applications

Information furnished is believed to be accurate and reliable. However, users should independently evaluate the suitability of and test each product selected for their own applications. Littelfuse products are not designed for, and shall not be used for, any purpose (including, without limitation, military, aerospace, medical, lifesaving, life-sustaining or nuclear facility applications, devices intended for surgical implant into the body, or any other application in which the failure or lack of desired operation of the product may result in personal injury, death, or property damage) other than those expressly set forth in applicable Littelfuse product documentation. Warranties granted by Littelfuse shall be deemed void for products used for any purpose not expressly set forth in applicable Littelfuse documentation. Littelfuse shall not be liable for any claims or damages arising out of products used in applications not expressly intended by Littelfuse as set forth in applicable Littelfuse documentation. The sale and use of Littelfuse products is subject to Littelfuse Terms and Conditions of Sale, unless otherwise agreed by Littelfuse.

Mouser Electronics

Authorized Distributor

Click to View Pricing, Inventory, Delivery & Lifecycle Information:

[Littelfuse:](#)

[PESD0402-140](#)