

ABSOLUTE MAXIMUM RATINGS

| Symbol | Parameter | Value | Unit |
|-----------------------------------|--|-------------|------|
| V _S | Supply Voltage | 20 | V |
| I _o | Output Peak Current (internally limited) | 2 | A |
| P _{tot} | Total Power Dissipation (T _{case} = 70°C) | 33 | W |
| T _{op} | Operating Temperature | 0 to 70 | °C |
| T _{stg} , T _j | Storage and Junction Temperature | -40 to +150 | °C |

THERMAL DATA

| Symbol | Description | Value | | Unit |
|------------------------|-------------------------------------|----------|--------|------|
| R _{th j-case} | Thermal Resistance Junction to case | Typ. 1.4 | Max. 2 | °C/W |

PIN CONNECTION (Top view)

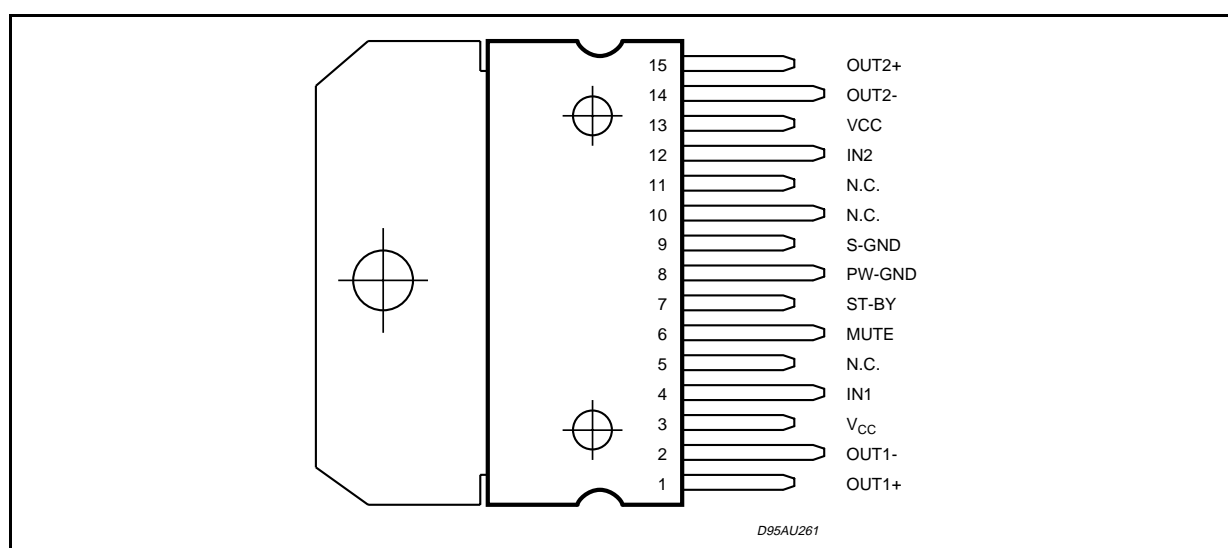

ELECTRICAL CHARACTERISTICS (V_{CC} = 16.5V, R_L = 8Ω, f = 1kHz, T_{amb} = 25°C unless otherwise specified.)

| Symbol | Parameter | Test Condition | Min. | Typ. | Max. | Unit |
|-------------------|---------------------------|---|------|------|------|------|
| V _{CC} | Supply Range | | 6.5 | | 18 | V |
| I _q | Total Quiescent Current | R _L = ∞ | | 50 | 65 | mA |
| V _{OS} | Output Offset Voltage | | | | 120 | mV |
| P _O | Output Power | THD = 10% | 13 | 15 | | W |
| THD | Total Harmonic Distortion | P _O = 1W | | 0.1 | 0.3 | % |
| | | P _O = 0.1W to 5W f = 100Hz to 15kHz | | | 1 | % |
| SVR | Supply Voltage Rejection | f = 100Hz V _R = 0.5V | 40 | 56 | | dB |
| CT | Crosstalk | | 46 | 60 | | dB |
| A _{MUTE} | Mute Attenuation | | 60 | 80 | | dB |
| T _w | Thermal Threshold | | | 150 | | °C |
| G _V | Closed Loop Voltage Gain | | 31 | 32 | 33 | dB |
| ΔG _v | Voltage Gain Matching | | | | 0.5 | dB |
| R _i | Input Resistance | | 25 | 30 | | KΩ |

ELECTRICAL CHARACTERISTICS (Continued)

| Symbol | Parameter | Test Condition | Min. | Typ. | Max. | Unit |
|-----------------|----------------------------------|---|------|------------|------|--------------------------------|
| $V_{T_{MUTE}}$ | Mute Threshold | $V_O = -30\text{dB}$ | 2.3 | 2.9 | 4.1 | V |
| $V_{T_{ST-BY}}$ | St-by Threshold | | 0.8 | 1.3 | 1.8 | V |
| I_{ST-BY} | ST-BY current $V_6 = \text{GND}$ | | | | 100 | μA |
| e_N | Total Output Noise Voltage | A curve $f = 20\text{Hz to } 20\text{kHz}$ | | 150 220 | 500 | μV μV |

APPLICATION SUGGESTION

STAND-BY AND MUTE FUNCTIONS

(A) Microprocessor Application

In order to avoid annoying "Pop-Noise" during Turn-On/Off transients, it is necessary to guarantee the right St-by and mute signals sequence. It is quite simple to obtain this function using a microprocessor (Fig. 1 and 2).

At first St-by signal (from μP) goes high and the voltage across the St-by terminal (Pin 7) starts to increase exponentially. The external RC network is intended to turn-on slowly the biasing circuits of

the amplifier, this to avoid "POP" and "CLICK" on the outputs.

When this voltage reaches the St-by threshold level, the amplifier is switched-on and the external capacitors in series to the input terminals (C3, C5) start to charge.

It's necessary to maintain the mute signal low until the capacitors are fully charged, this to avoid that the device goes in play mode causing a loud "Pop Noise" on the speakers.

A delay of 100-200ms between St-by and mute signals is suitable for a proper operation.

Figure 1: Microprocessor Application

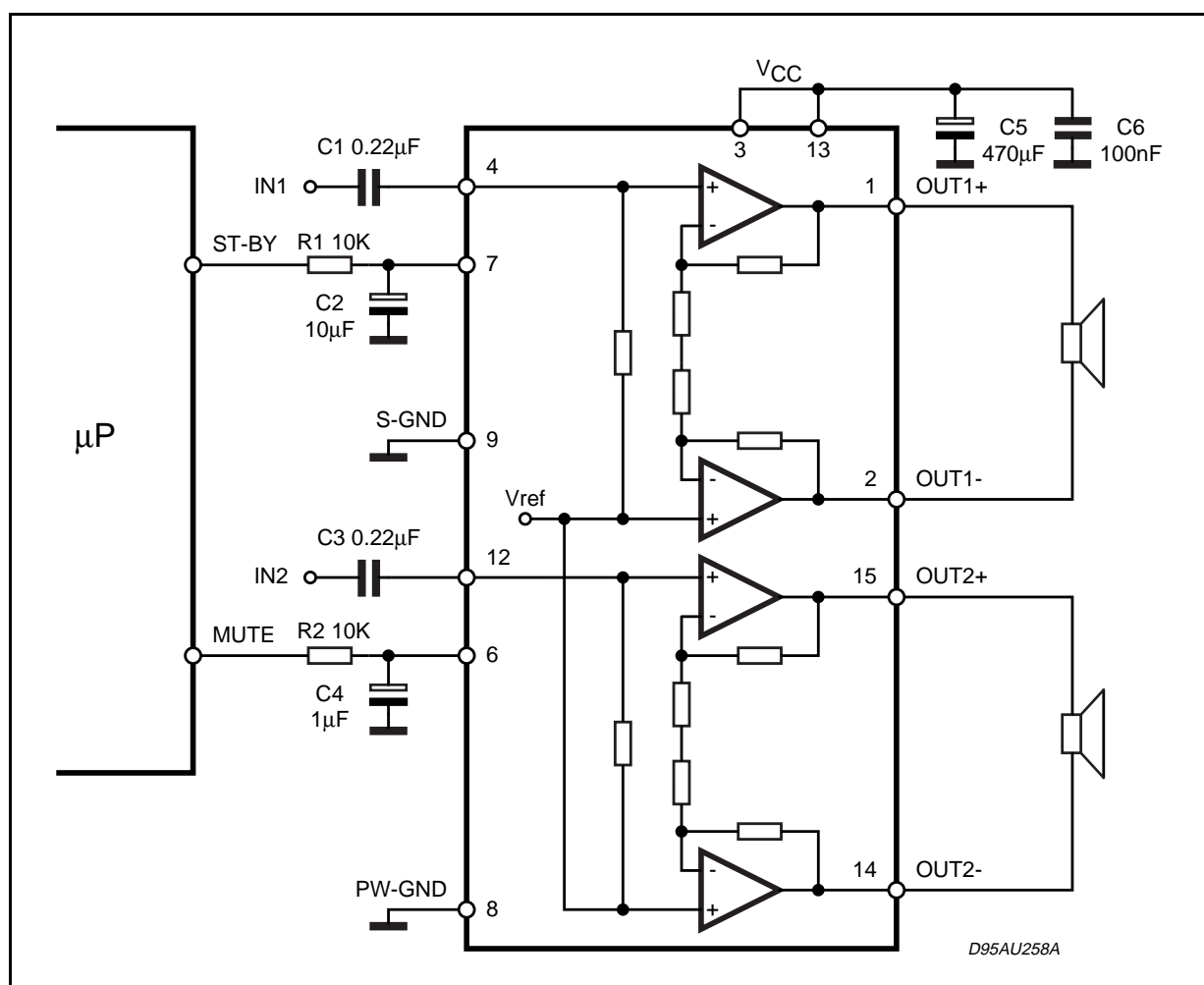
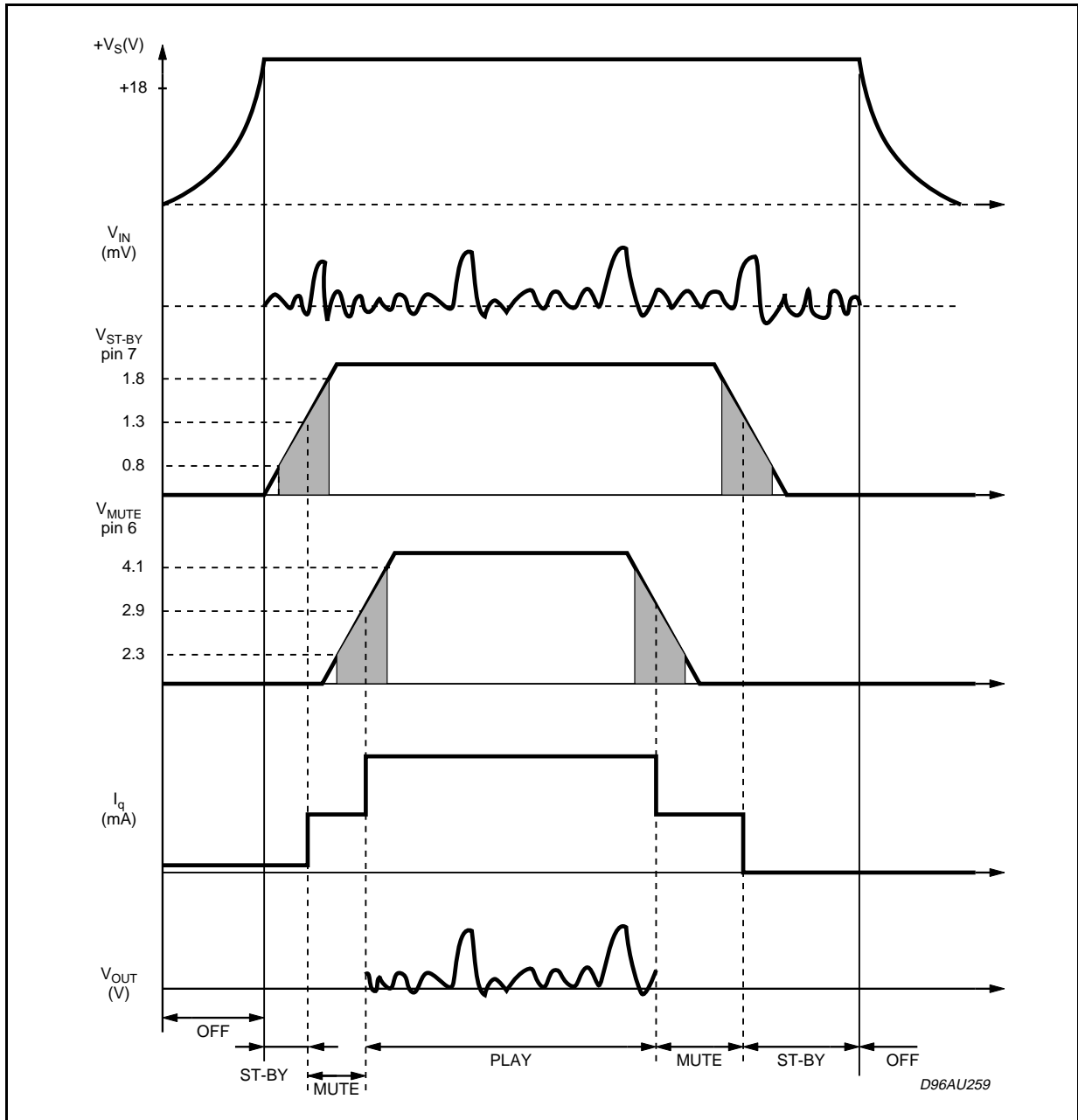

Figure 2: Microprocessor Driving Signals.



(B) Low Cost Application

In low cost applications where the mP is not present, the suggested circuit is shown in fig.3.

The St-by and mute terminals are tied together and they are connected to the supply line via an

external voltage divider.

The device is switched-on/off from the supply line and the external capacitor C4 is intended to delay the St-by and mute threshold exceeding, avoiding "Popping" problems.

Figure 3: Stand-alone Low-cost Application.

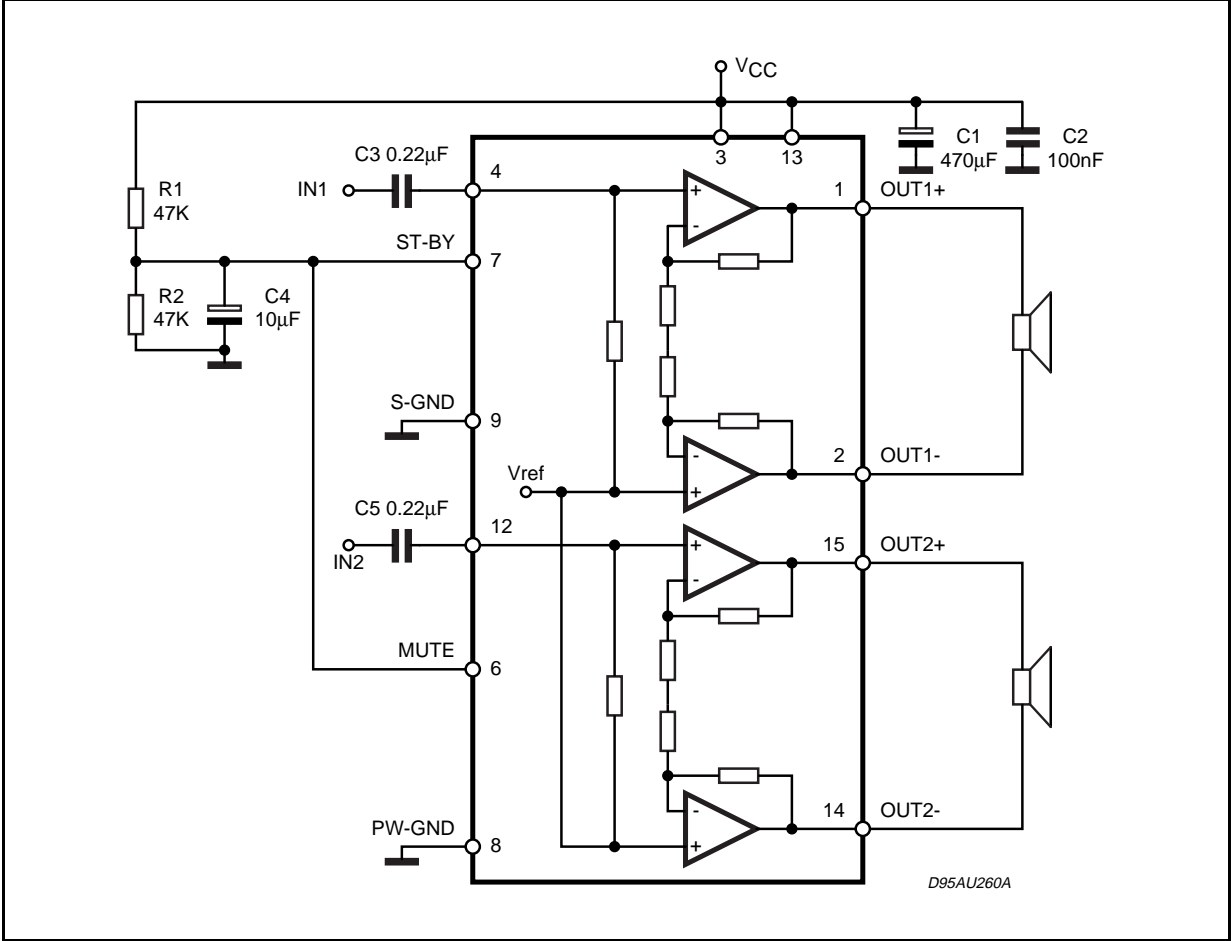

Figure 3b: PCB and Component Layout of the Application Circuit (Fig. 1).

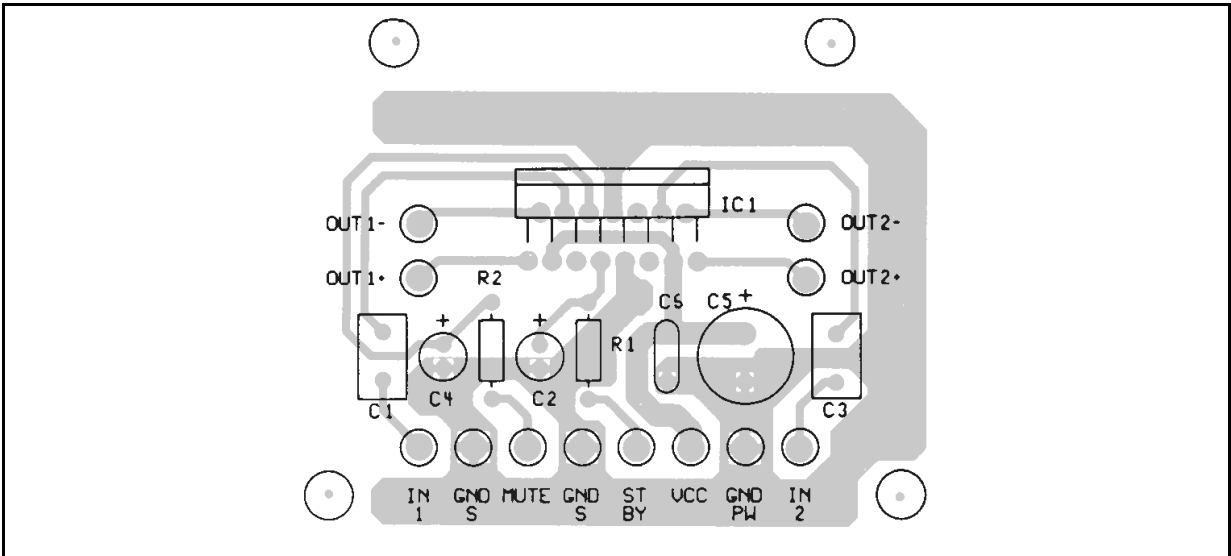

Figure 4: Distortion vs Output Power

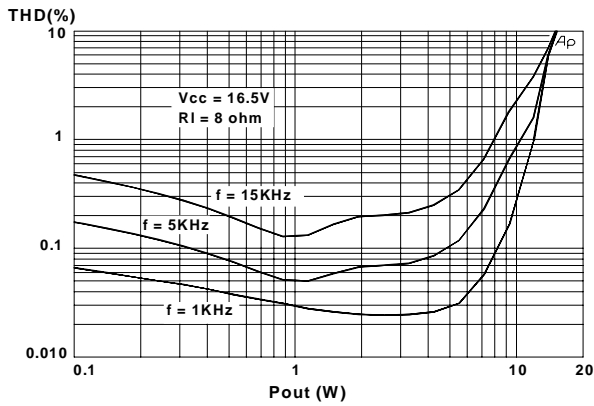

Figure 5: Distortion vs Output Power

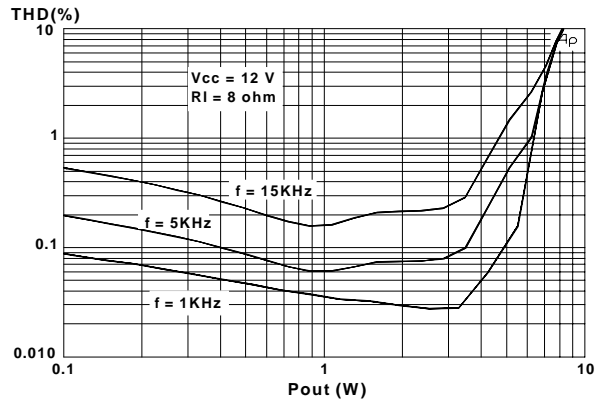

Figure 6: Distortion vs Frequency

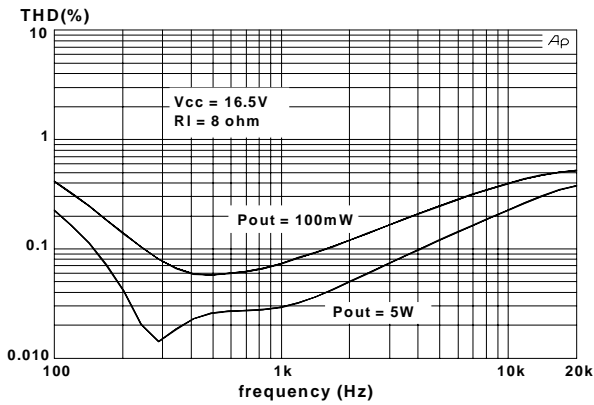

Figure 7: Frequency Response

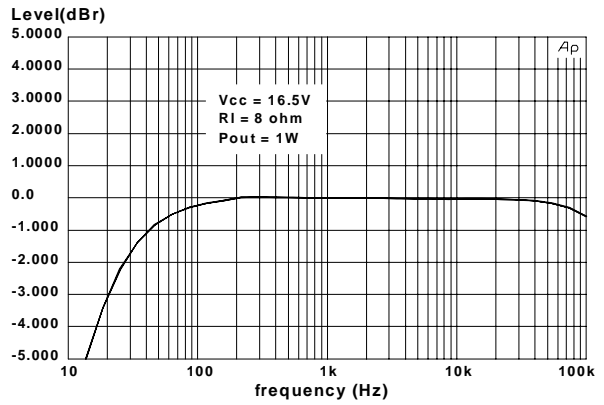

Figure 8: Output Power vs Supply Voltage

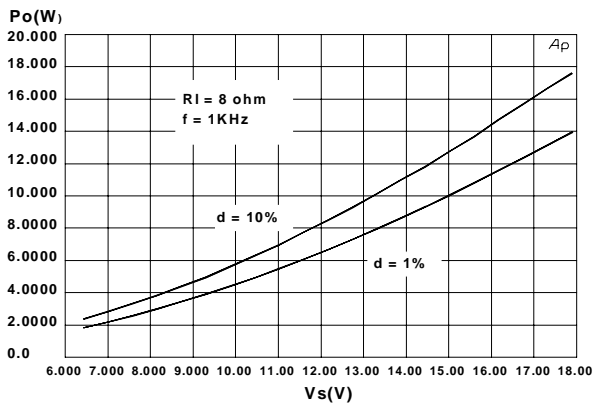

Figure 9: Total Power Dissipation & Efficiency vs Output Power

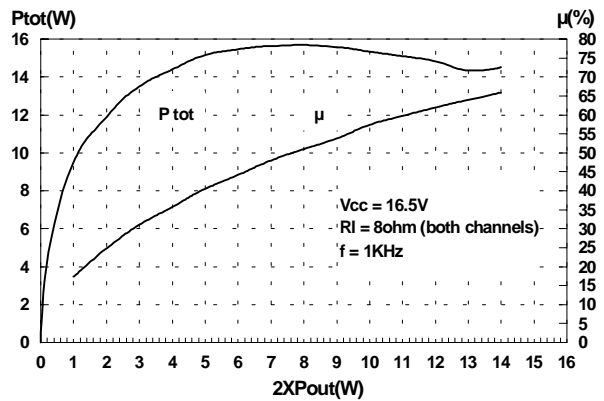

Figure 10: Mute Attenuation vs. V pin.6

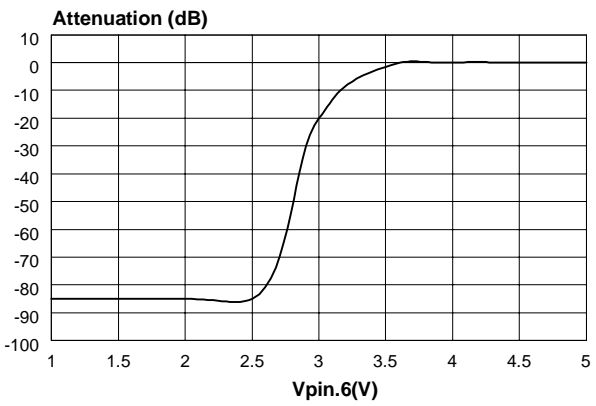

Figure 11: Stand-By Attenuation vs Vpin.7

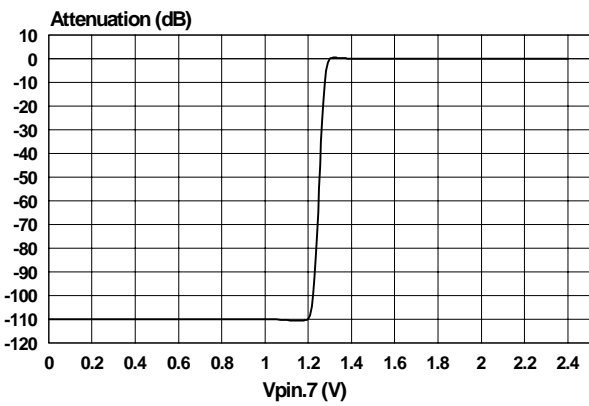
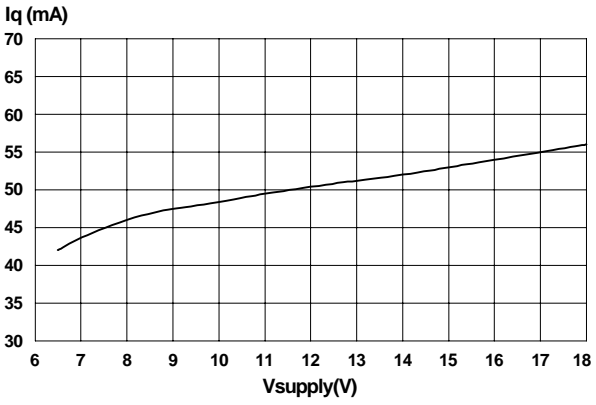
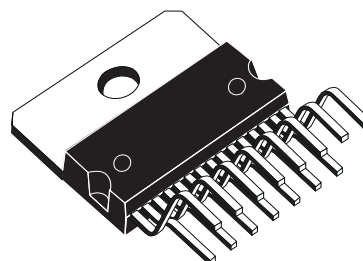

Figure 12: Quiscent Current vs. Supply Voltage



| DIM. | mm | | | inch | | |
|------|-------|-------|-------|-------|-------|-------|
| | MIN. | TYP. | MAX. | MIN. | TYP. | MAX. |
| A | | | 5 | | | 0.197 |
| B | | | 2.65 | | | 0.104 |
| C | | | 1.6 | | | 0.063 |
| D | | 1 | | | 0.039 | |
| E | 0.49 | | 0.55 | 0.019 | | 0.022 |
| F | 0.66 | | 0.75 | 0.026 | | 0.030 |
| G | 1.02 | 1.27 | 1.52 | 0.040 | 0.050 | 0.060 |
| G1 | 17.53 | 17.78 | 18.03 | 0.690 | 0.700 | 0.710 |
| H1 | 19.6 | | | 0.772 | | |
| H2 | | | 20.2 | | | 0.795 |
| L | 21.9 | 22.2 | 22.5 | 0.862 | 0.874 | 0.886 |
| L1 | 21.7 | 22.1 | 22.5 | 0.854 | 0.870 | 0.886 |
| L2 | 17.65 | | 18.1 | 0.695 | | 0.713 |
| L3 | 17.25 | 17.5 | 17.75 | 0.679 | 0.689 | 0.699 |
| L4 | 10.3 | 10.7 | 10.9 | 0.406 | 0.421 | 0.429 |
| L7 | 2.65 | | 2.9 | 0.104 | | 0.114 |
| M | 4.25 | 4.55 | 4.85 | 0.167 | 0.179 | 0.191 |
| M1 | 4.63 | 5.08 | 5.53 | 0.182 | 0.200 | 0.218 |
| S | 1.9 | | 2.6 | 0.075 | | 0.102 |
| S1 | 1.9 | | 2.6 | 0.075 | | 0.102 |
| Dia1 | 3.65 | | 3.85 | 0.144 | | 0.152 |

OUTLINE AND MECHANICAL DATA



Multiwatt15 V

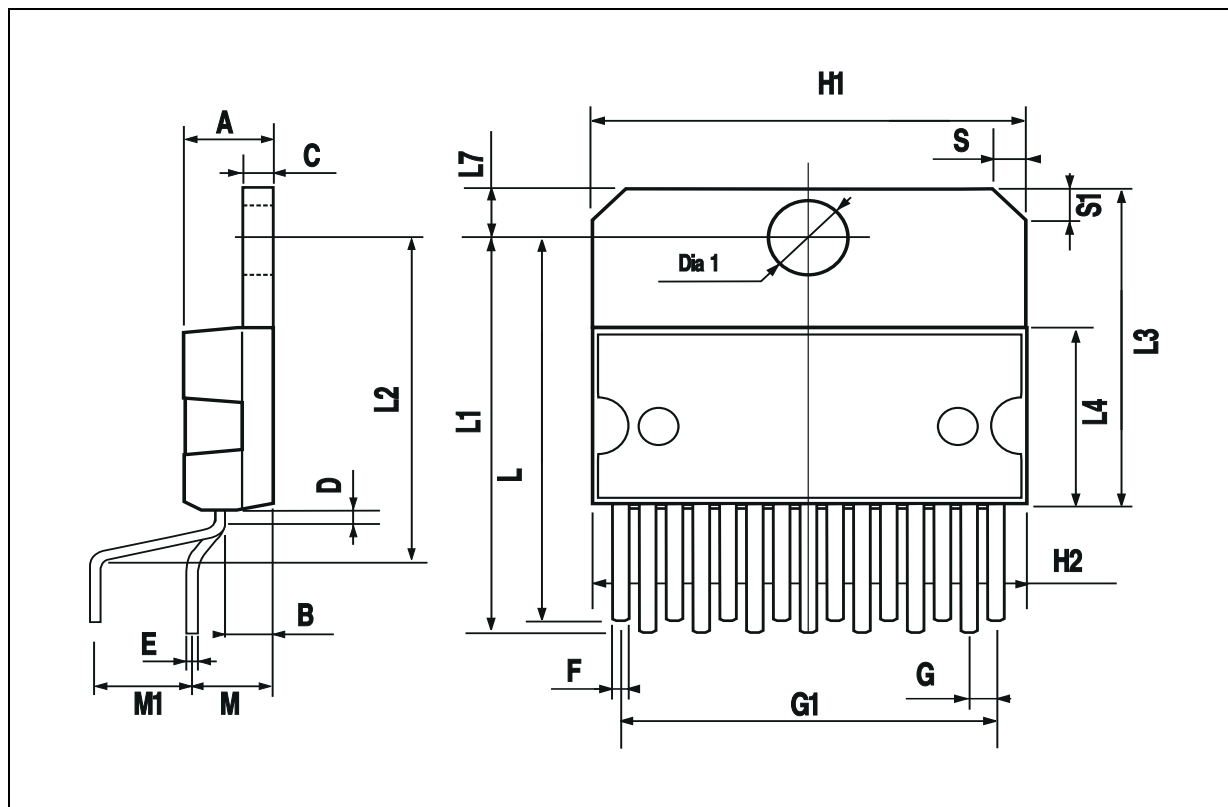

Information furnished is believed to be accurate and reliable. However, STMicroelectronics assumes no responsibility for the consequences of use of such information nor for any infringement of patents or other rights of third parties which may result from its use. No license is granted by implication or otherwise under any patent or patent rights of STMicroelectronics. Specifications mentioned in this publication are subject to change without notice. This publication supersedes and replaces all information previously supplied. STMicroelectronics products are not authorized for use as critical components in life support devices or systems without express written approval of STMicroelectronics.

The ST logo is a registered trademark of STMicroelectronics.
All other names are the property of their respective owners

© 2003 STMicroelectronics - All rights reserved

STMicroelectronics GROUP OF COMPANIES

Australia – Belgium - Brazil - Canada - China – Czech Republic - Finland - France - Germany - Hong Kong - India - Israel - Italy - Japan -
Malaysia - Malta - Morocco - Singapore - Spain - Sweden - Switzerland - United Kingdom - United States

www.st.com



Mouser Electronics

Authorized Distributor

Click to View Pricing, Inventory, Delivery & Lifecycle Information:

[STMicroelectronics:](#)

[TDA7297](#)