

HCF40107B

INPUT EQUIVALENT CIRCUIT

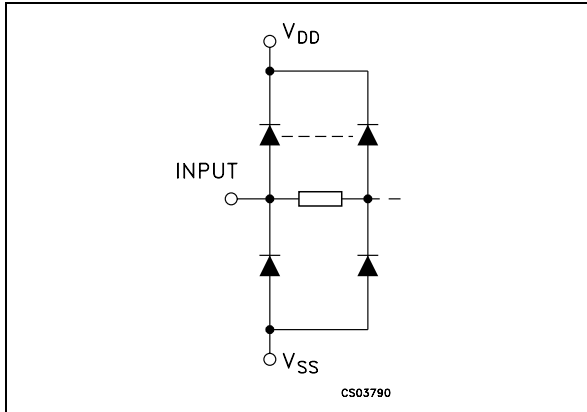

PIN DESCRIPTION

PIN No	SYMBOL	NAME AND FUNCTION
2, 1, 7, 6	A, B, D, E	Input
3, 5	C, F	Outputs
4	V_{SS}	Negative Supply Voltage
8	V_{DD}	Positive Supply Voltage

FUNCTIONAL DIAGRAM

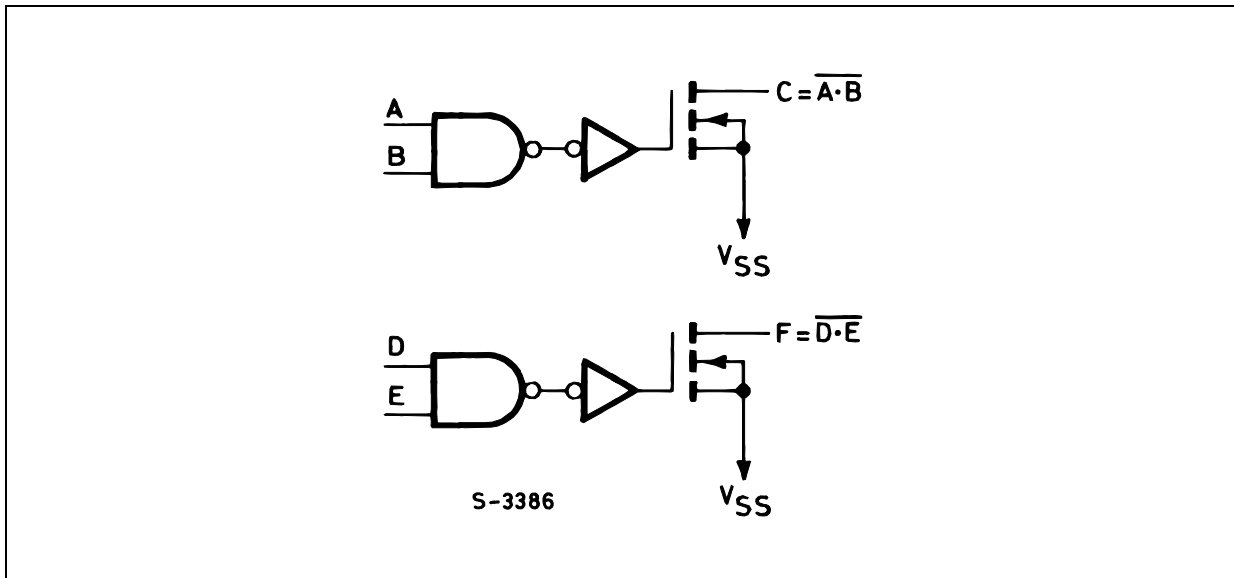

TRUTH TABLE

A	B	C	
L	L	H*	Z#
H	L	H*	Z#
L	H	H*	Z#
H	H	L	

* : Requires external and pull-up resistor (R_L) to V_{DD} .
 # : Without pull-up resistor (3-state).

LOGIC DIAGRAM

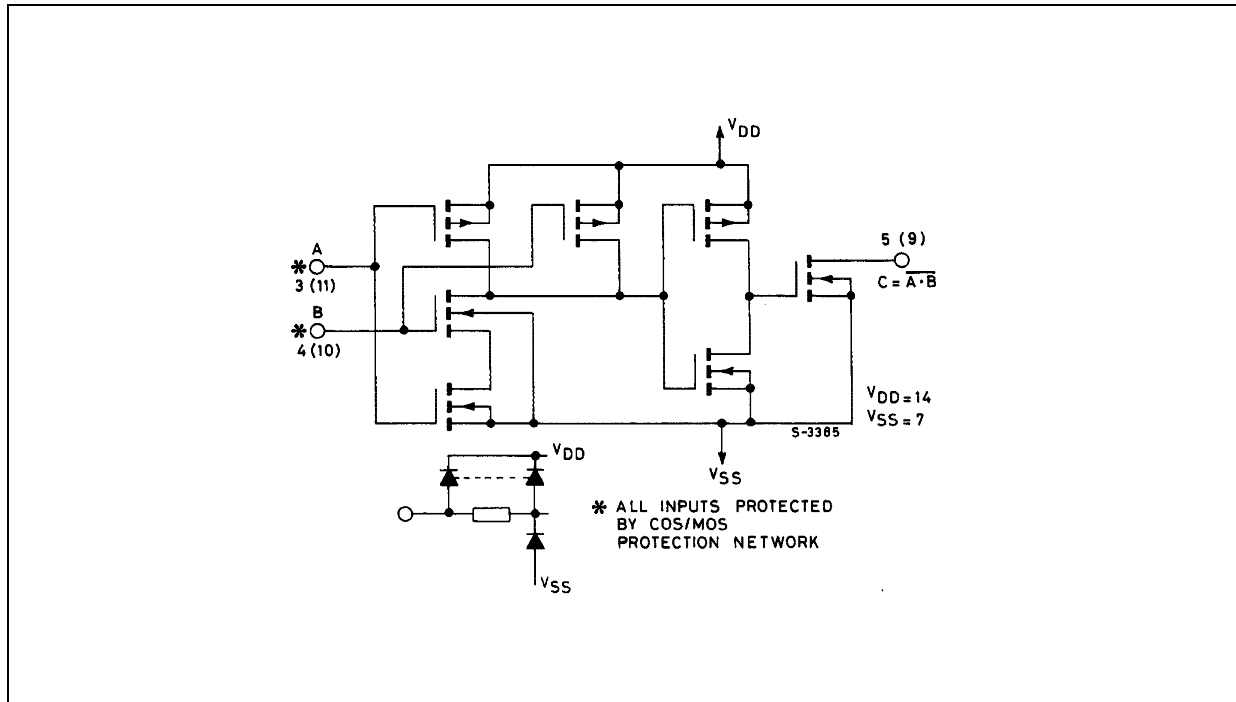

ABSOLUTE MAXIMUM RATINGS

Symbol	Parameter	Value	Unit
V_{DD}	Supply Voltage	-0.5 to +22	V
V_I	DC Input Voltage	-0.5 to $V_{DD} + 0.5$	V
I_I	DC Input Current	± 10	mA
P_D	Power Dissipation per Package	200	mW
	Power Dissipation per Output Transistor	100	mW
T_{op}	Operating Temperature	-55 to +125	$^{\circ}\text{C}$
T_{stg}	Storage Temperature	-65 to +150	$^{\circ}\text{C}$

Absolute Maximum Ratings are those values beyond which damage to the device may occur. Functional operation under these conditions is not implied.

All voltage values are referred to V_{SS} pin voltage.

RECOMMENDED OPERATING CONDITIONS

Symbol	Parameter	Value	Unit
V_{DD}	Supply Voltage	3 to 20	V
V_I	Input Voltage	0 to V_{DD}	V
T_{op}	Operating Temperature	-55 to 125	$^{\circ}\text{C}$

DC SPECIFICATIONS

Symbol	Parameter	Test Condition				Value						Unit	
		V _I (V)	V _O (V)	I _{OL} (μ A)	V _{DD} (V)	T _A = 25°C			-40 to 85°C		-55 to 125°C		
						Min.	Typ.	Max.	Min.	Max.	Min.		Max.
I _L	Quiescent Current	0/5			5		0.02	5		150		30	μ A
		0/10			10		0.02	10		300		60	
		0/15			15		0.02	20		600		120	
		0/20			20		0.04	100		3000		600	
V _{IH} **	High Level Input Voltage		0.5/4.5	<1	5	3.5			3.5		3.5		V
			1/9	<1	10	7			7		7		
			1.5/13.5	<1	15	11			11		11		
V _{IL} **	Low Level Input Voltage		4.5/0.5	<1	5			1.5		1.5		1.5	V
			9/1	<1	10			3		3		3	
			13.5/1.5	<1	15			4		4		4	
I _{OL}	Output Sink Current	5	0.4		5	21	32		16		12		mA
		5	1		5	44	68		30		25		
		10	0.5		10	49	74		37		28		
		10	1		10	89	136		68		51		
		15	0.5		15	66	100		50		38		
I _{OH}	Output Drive Current	No Internal Pull-up Device										mA	
I _{IH} , I _{IL}	Input Leakage Current	0/18	Any Input		18		$\pm 10^{-5}$	± 0.1		± 0.1		± 1	μ A
I _{OH} , I _{OL} ***	3-State Output Leakage Current	0/18	18		18		$\pm 10^{-4}$	2		2		20	μ A
C _I	Input Capacitance		Any Input				5	7.5					pF
C _O	Output Capacitance		Any Output				30						pF

The Noise Margin for both "1" and "0" level is: 1V min. with V_{DD}=5V, 2V min. with V_{DD}=10V, 2.5V min. with V_{DD}=15V

** Measured with external pull-up resistor, R_L = 10k Ω to V_{DD}.

*** Forced output disabled.

DYNAMIC ELECTRICAL CHARACTERISTICS (T_{amb} = 25°C, C_L = 50pF, R_L = 200K Ω , t_r = t_f = 20 ns)

Symbol	Parameter	Test Condition			Value (*)			Unit
		V _{DD} (V)			Min.	Typ.	Max.	
t _{PHL} t _{PLH}	Propagation Delay Time High to Low	5	R _L * = 120 Ω			100	200	ns
		10			45	90		
		15			30	60		
	Low to High	5	R _L * = 120 Ω			100	200	ns
		10			60	120		
		15			50	100		
t _{THL} t _{TLH}	Transition Time High to Low	5	R _L * = 120 Ω			50	100	ns
		10			20	40		
		15			10	20		
	Low to High	5	R _L * = 120 Ω			50	100	ns
		10			35	70		
		15			25	50		

(*) R_L is external pull-up resistor to V_{DD}.

TYPICAL APPLICATIONS

Line-driver Circuit.

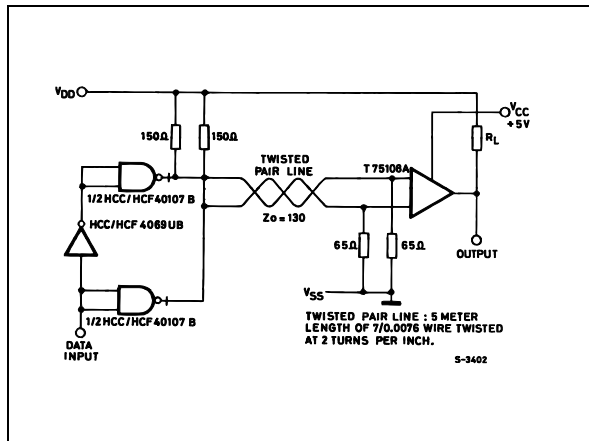

A 2.2-watt Incandescent Lamp-driver Circuit.

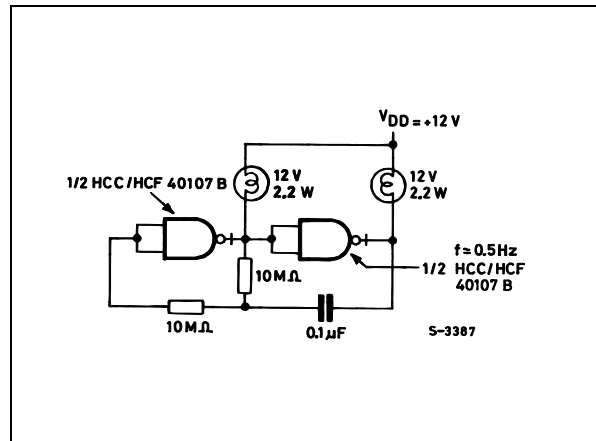

Interface of 40107B with Triac, with COS/MOS Component and Triac isolated.

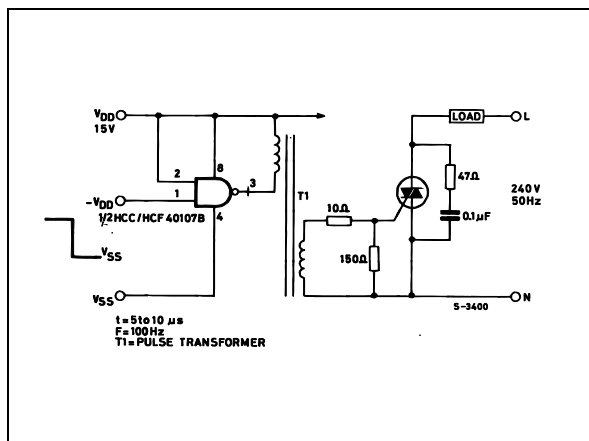

Solenoid Driver Circuit

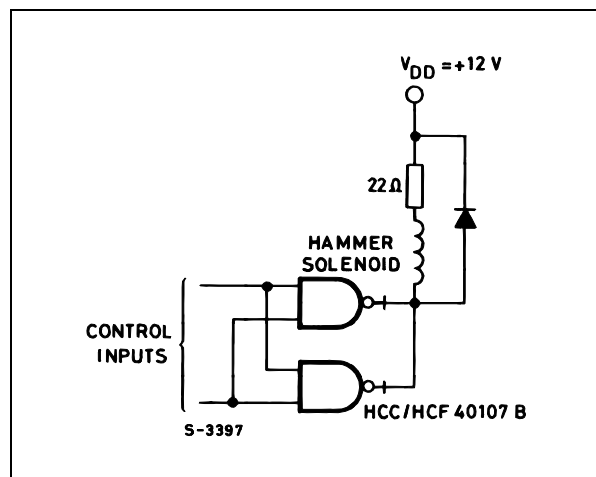

Direct Dc Driver Interface of 40107B with a Triac.

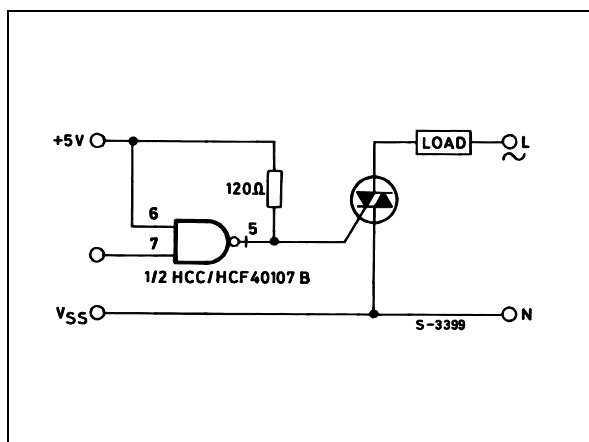

HCF40107B

Multiplexed Led Circuit

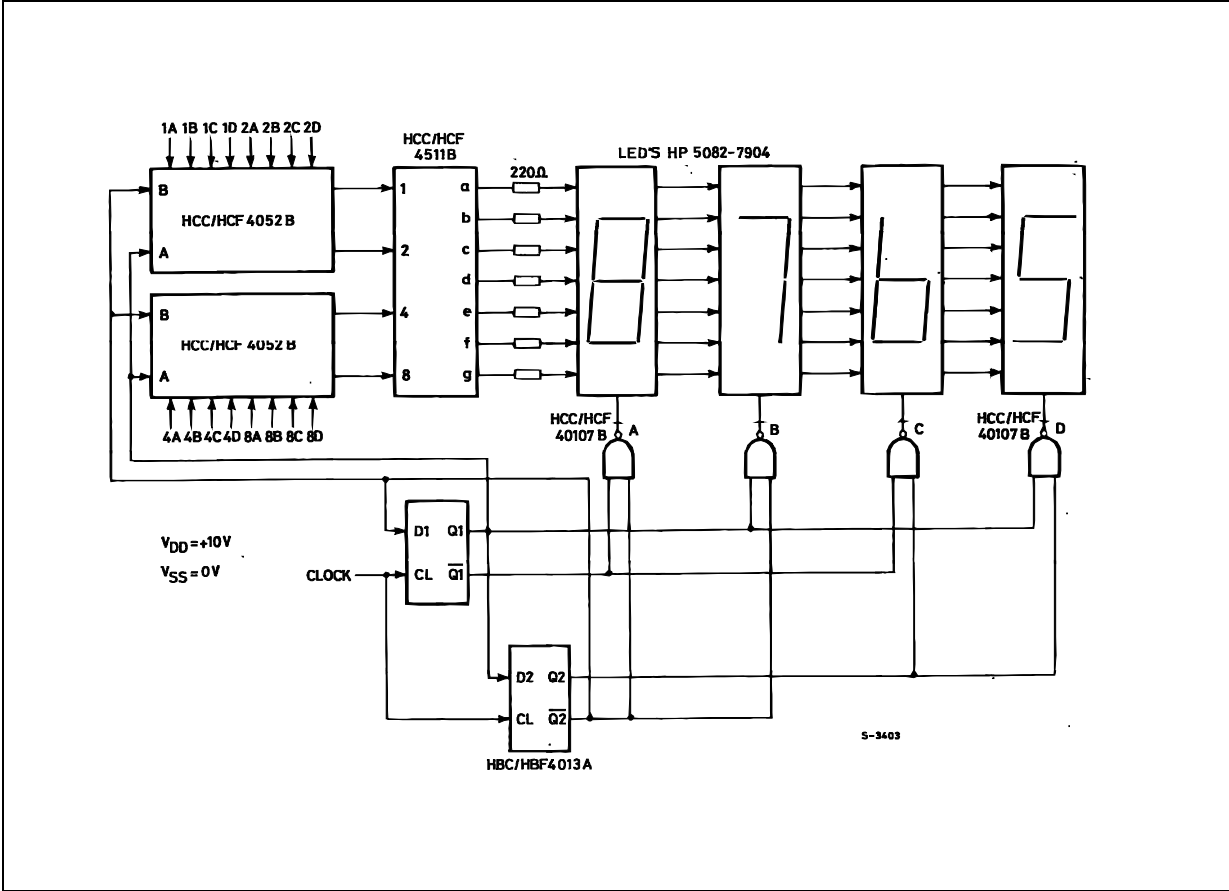

Motor-controller Circuit

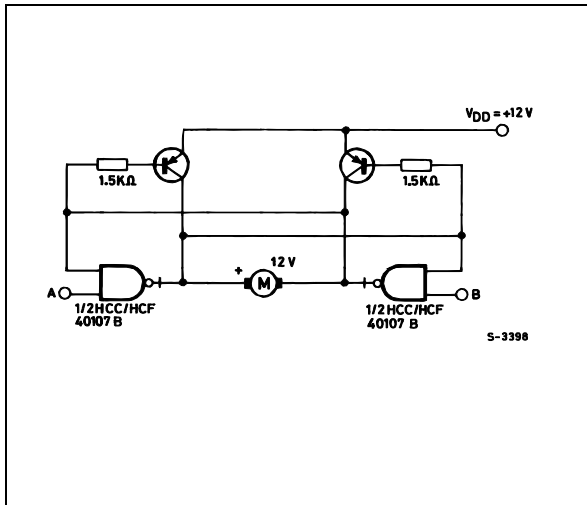

A	B	MOTOR FUNCTION
L	L	OFF
H	L	COUNTER CLOCKWISE
H	H	AS PREVIOUS STATE
L	H	CLOCKWISE
H	H	AS PREVIOUS STATE

Led Driver Circuit

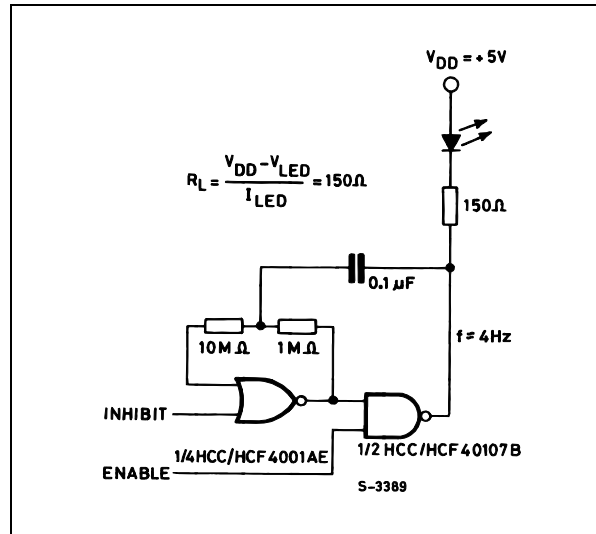

INHIBIT	ENABLE	OUTPUT
L	L	OFF
H	L	OFF
L	H	OFF
L	H	ON

TEST CIRCUIT

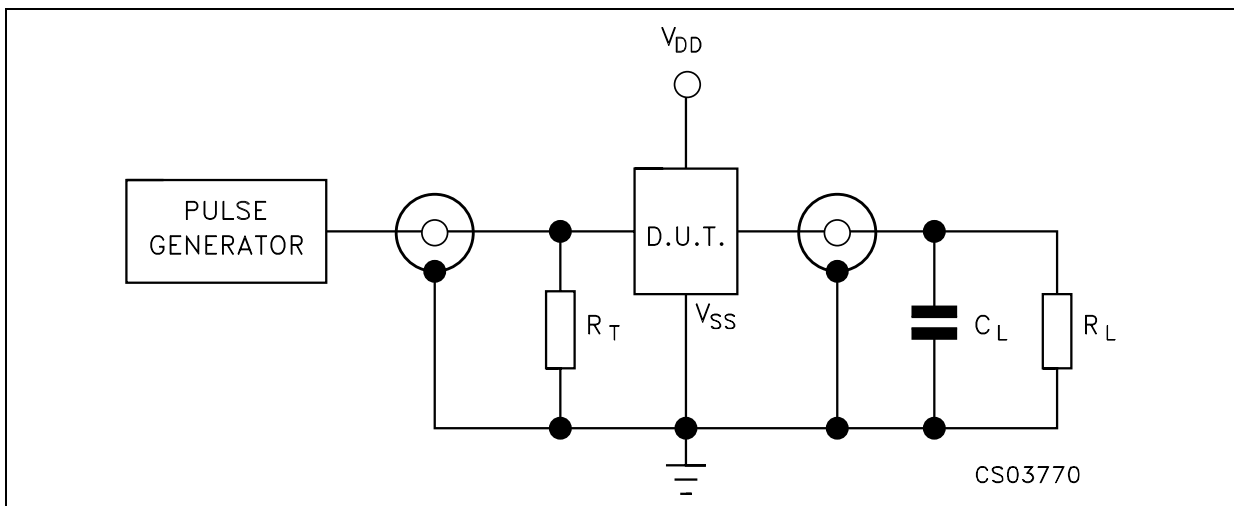

$C_L = 50\text{pF}$ or equivalent (includes jig and probe capacitance)
 $R_L = 200\text{K}\Omega$
 $R_T = Z_{OUT}$ of pulse generator (typically 50Ω)

HCF40107B

WAVEFORM : PROPAGATION DELAY TIMES (f=1MHz; 50% duty cycle)

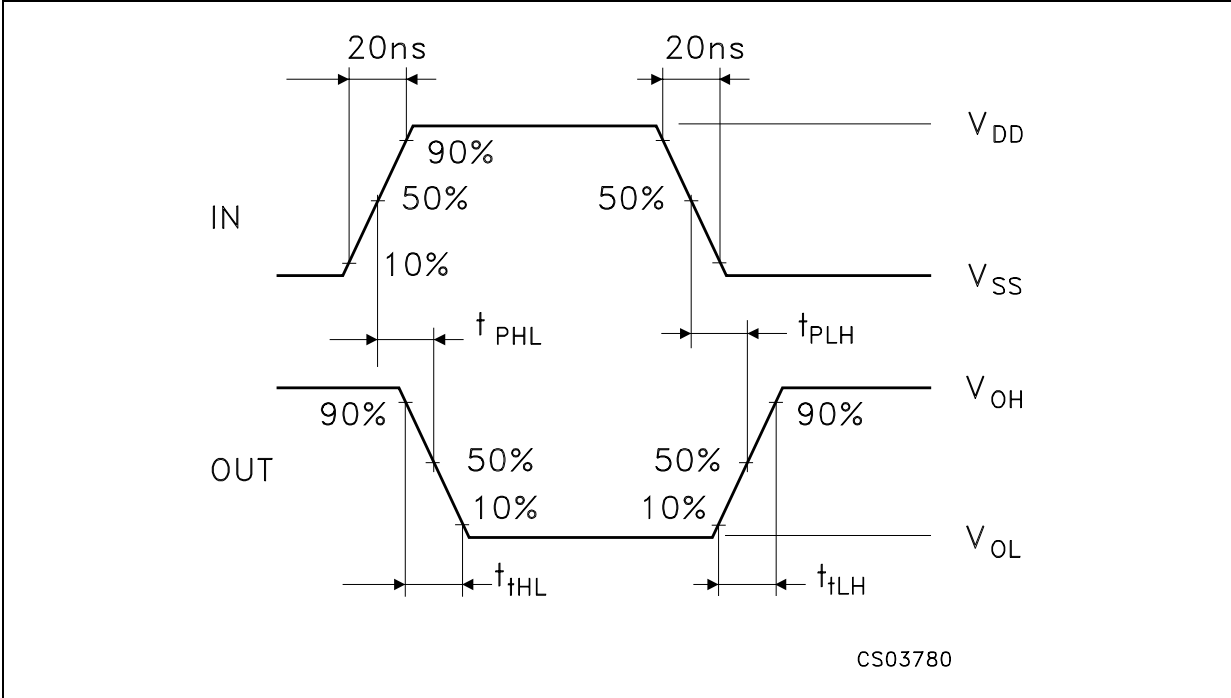

Plastic DIP-8 MECHANICAL DATA						
--------------------------------------	--	--	--	--	--	--

DIM.	mm.			inch		
	MIN.	TYP.	MAX.	MIN.	TYP.	MAX.
A		3.3			0.130	
a1	0.7			0.028		
B	1.39		1.65	0.055		0.065
B1	0.91		1.04	0.036		0.041
b		0.5			0.020	
b1	0.38		0.5	0.015		0.020
D			9.8			0.386
E		8.8			0.346	
e		2.54			0.100	
e3		7.62			0.300	
e4		7.62			0.300	
F			7.1			0.280
I			4.8			0.189
L		3.3			0.130	
Z	0.44		1.6	0.017		0.063

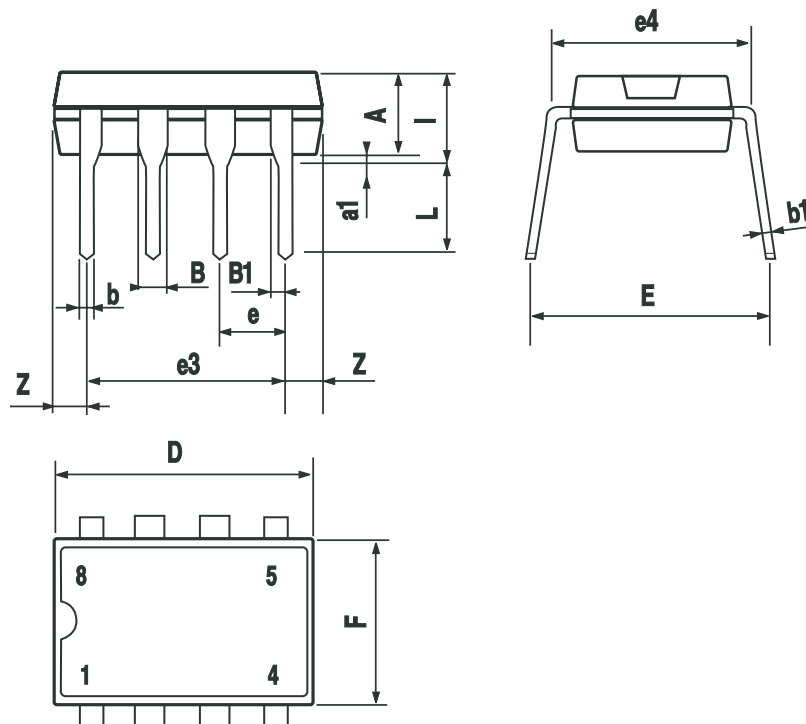

P001F

SO-8 MECHANICAL DATA

DIM.	mm.			inch		
	MIN.	TYP.	MAX.	MIN.	TYP.	MAX.
A			1.75			0.068
a1	0.1		0.25	0.003		0.009
a2			1.65			0.064
a3	0.65		0.85	0.025		0.033
b	0.35		0.48	0.013		0.018
b1	0.19		0.25	0.007		0.010
C	0.25		0.5	0.010		0.019
c1	45° (typ.)					
D	4.8		5.0	0.189		0.196
E	5.8		6.2	0.228		0.244
e		1.27			0.050	
e3		3.81			0.150	
F	3.8		4.0	0.149		0.157
L	0.4		1.27	0.015		0.050
M			0.6			0.023
S	8° (max.)					

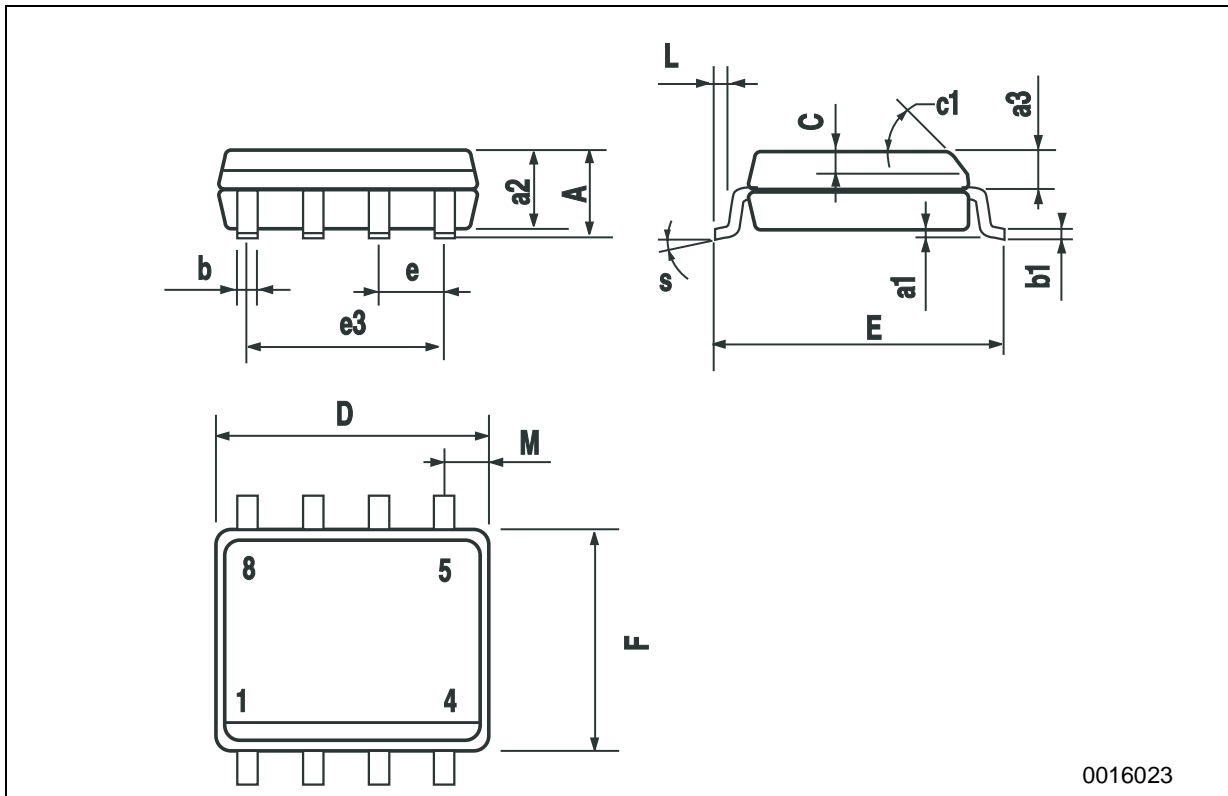

0016023

Information furnished is believed to be accurate and reliable. However, STMicroelectronics assumes no responsibility for the consequences of use of such information nor for any infringement of patents or other rights of third parties which may result from its use. No license is granted by implication or otherwise under any patent or patent rights of STMicroelectronics. Specifications mentioned in this publication are subject to change without notice. This publication supersedes and replaces all information previously supplied. STMicroelectronics products are not authorized for use as critical components in life support devices or systems without express written approval of STMicroelectronics.

© The ST logo is a registered trademark of STMicroelectronics

© 2002 STMicroelectronics - Printed in Italy - All Rights Reserved
STMicroelectronics GROUP OF COMPANIES

Australia - Brazil - Canada - China - Finland - France - Germany - Hong Kong - India - Israel - Italy - Japan - Malaysia - Malta - Morocco
Singapore - Spain - Sweden - Switzerland - United Kingdom - United States.

© <http://www.st.com>



Mouser Electronics

Authorized Distributor

Click to View Pricing, Inventory, Delivery & Lifecycle Information:

[STMicroelectronics:](#)

[HCF40107BEY](#) [HCF40107BM1](#) [HCF40107M013TR](#)