

Technical description

Weight	5.68 kg
Size	355 mm
Motor size	84
Rotor surface	Painted black
Electronics housing material	Die-cast aluminum
Impeller material	Sheet aluminum
Number of blades	6
Direction of rotation	Clockwise, viewed toward rotor
Degree of protection	IP54
Insulation class	"B"
Moisture (F) / Environmental (H) protection class	H1
Max. permitted ambient temp. for motor (transport/storage)	+80 °C
Min. permitted ambient temp. for motor (transport/storage)	-40 °C
Installation position	Shaft horizontal or rotor on bottom; rotor on top on request
Condensation drainage holes	None
Mode	S1
Motor bearing	Ball bearing
Technical features	<ul style="list-style-type: none"> - Output 10 VDC, max. 1.1 mA - Alarm relay - Motor current limitation - Soft start - Control input 0-10 VDC / PWM - Thermal overload protection for electronics/motor - Line undervoltage detection
EMC immunity to interference	According to EN 61000-6-2
EMC circuit feedback	According to EN 61000-3-2/3
EMC interference emission	According to EN 61000-6-3
Touch current according to IEC 60990 (measuring circuit Fig. 4, TN system)	<= 3.5 mA
Motor protection	Thermal overload protector (TOP) internally connected
With cable	Variable
Protection class	I (with customer connection of protective earth)
Conformity with standards	EN 61800-5-1; CE
Approval	CSA C22.2 No. 77 + CAN/CSA-E60730-1; CCC; EAC; UL 1004-3 + 60730-1

Product drawing

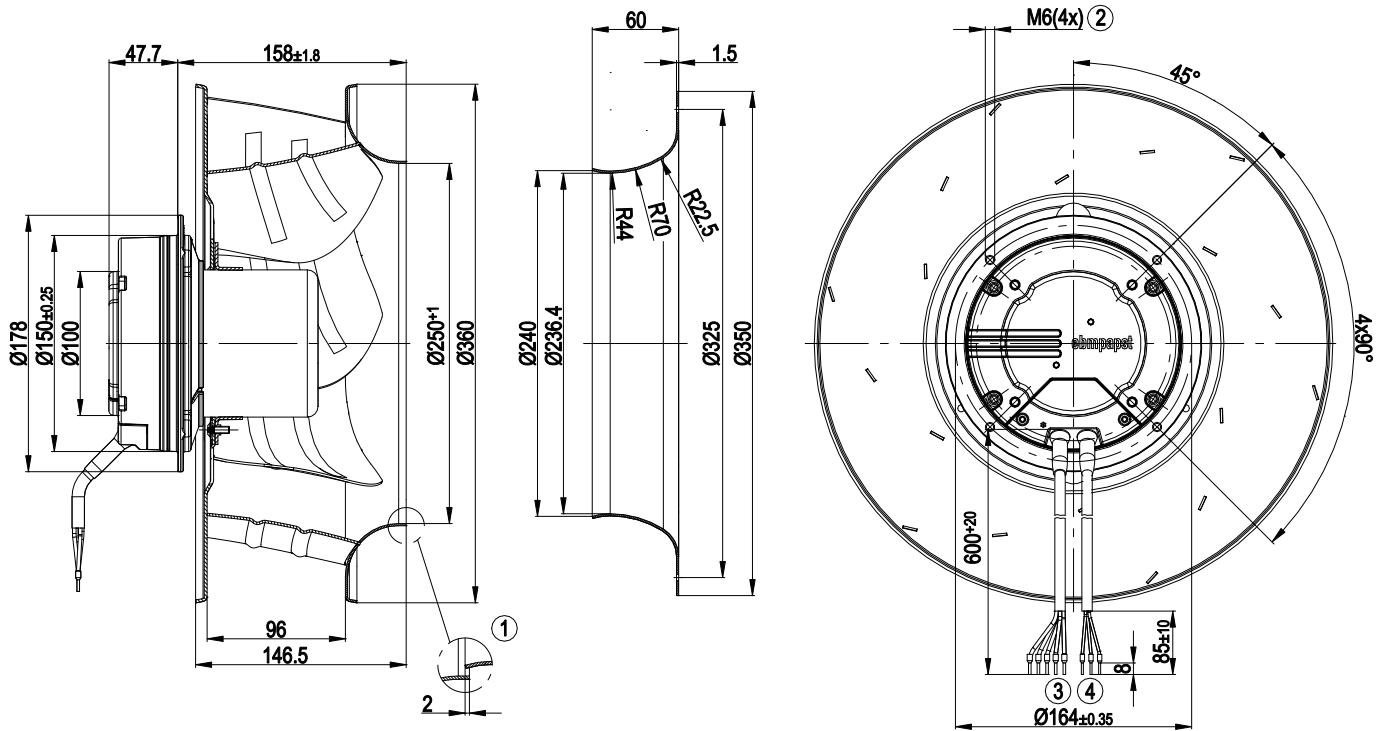

1	Accessory part: Inlet ring 35560-2-4013 not included in scope of delivery, other inlet rings on request
2	Max. clearance for screw 10 mm
3	Cable AWG22, 3x crimped ferrules
4	Cable AWG18, 5x crimped ferrules

EC centrifugal fan

backward-curved, single-intake

Connection diagram

Customer circuit

Application notes for various control options

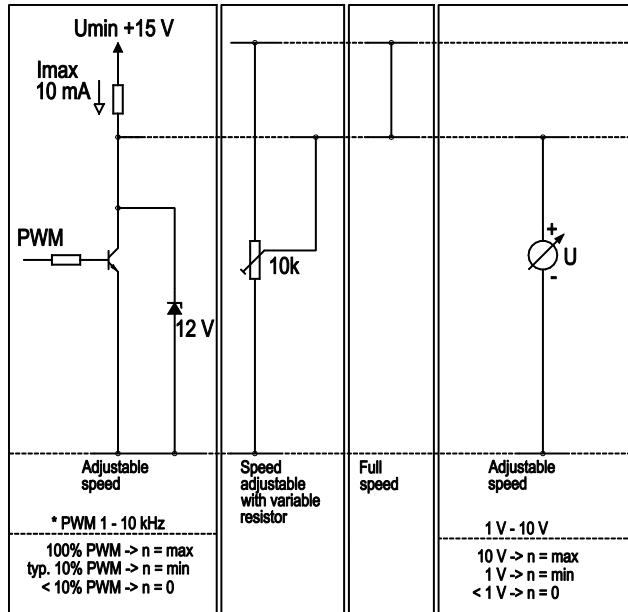

Connection

Fan / Motor

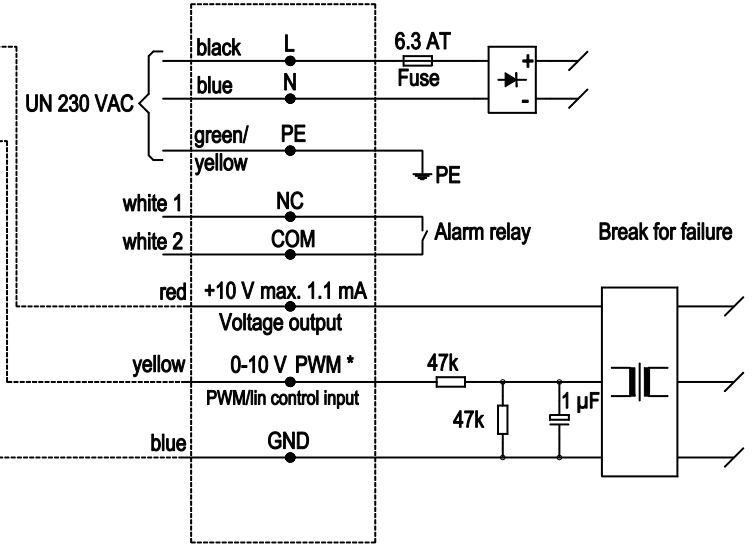

Curves: Air performance 50 Hz

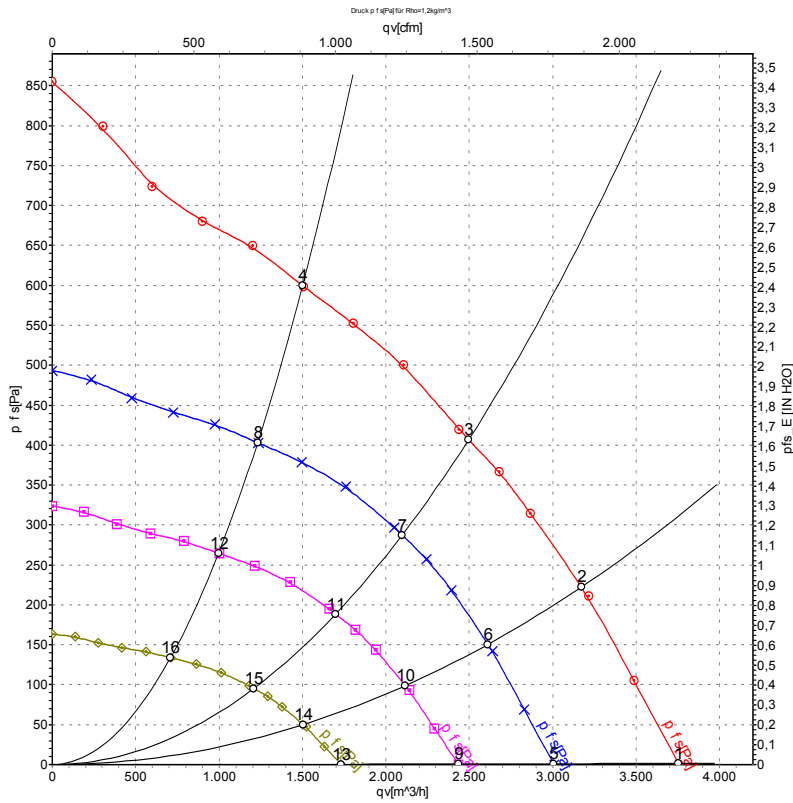

Measurement: LU-68189-1

Air performance measured according to ISO 5801 installation category A. For detailed information on the measurement setup, contact ebm-papst. Intake sound level: Sound power level according to ISO 13347 / sound pressure level measured at 1 m distance from fan axis. The values given are valid under the specified measuring conditions and may vary due to conditions of installation. For deviations from the standard configuration, the parameters have to be checked on the installed unit.

Measured values

	U	f	n	P _{ed}	I	LpA _{in}	q _v	P _{fs}	q _v	P _{fs}
	V	Hz	min ⁻¹	W	A	dB(A)	m ³ /h	Pa	cfm	in. wg
1	230	50	1975	391	2.48	77	3750	0	2210	0.00
2	230	50	1920	468	2.95	73	3170	225	1865	0.90
3	230	50	1890	502	3.15	69	2495	405	1470	1.63
4	230	50	1925	473	2.99	71	1500	600	885	2.41
5	230	50	1580	201	1.27	71	3005	0	1770	0.00
6	230	50	1580	261	1.64	67	2610	152	1535	0.61
7	230	50	1580	298	1.89	64	2100	288	1235	1.16
8	230	50	1580	261	1.65	64	1230	403	725	1.62
9	230	50	1280	107	0.68	65	2435	0	1435	0.00
10	230	50	1280	139	0.87	61	2115	100	1245	0.40
11	230	50	1280	159	1.01	58	1700	189	1000	0.76
12	230	50	1280	139	0.88	59	995	265	585	1.06
13	230	50	910	38	0.24	55	1730	0	1020	0.00
14	230	50	910	50	0.31	52	1505	50	885	0.20
15	230	50	910	57	0.36	49	1210	95	710	0.38
16	230	50	910	50	0.32	50	710	134	415	0.54

U = Voltage · f = Frequency · n = Speed (rpm) · P_{ed} = Power consumption · I = Current draw · LpA_{in} = Sound pressure level intake side · q_v = Air flow · p_{fs} = Pressure increase

