



Z86C93

CMOS Z8® MULTIPLY/DIVIDE MICROCONTROLLER

FEATURES

- Complete microcontroller, up to 24 I/O lines, and up to 64 Kbytes of addressable external space each for program and data memory.
- 16-bit x 16-bit hardwired multiplier with 32-bit product in 17 clock cycles.
- 32-bit x 16-bit hardwired divider with 16-bit quotient and 16-bit remainder in 20 clock cycles.
- 256-byte register file, including 236 general-purpose registers, up to three I/O port registers and 16 status and control registers.
- 17-byte Expanded Register File, including two general-purpose registers and 15 status and control registers.
- Vectored, priority interrupts for I/O, counter/timers and UART.
- On-chip oscillator that accepts crystal or external clock drive.
- Two 16-bit counter timers with 6-bit prescalers.
- Third 16-bit counter/timer with 4-bit prescaler, one capture register and a fast decrement mode.
- Register Pointer for short, fast instructions that can access any one of the sixteen working register groups.
- Additional emulation signals SCLK, IACK, and /SYNC are made available.
- Two low power standby modes, STOP and HALT
- Full-duplex UART
- $3.3 \pm 10\%$ volt operation at 25 MHz
- $5.0 \pm 10\%$ volt operation at 20, 25 and 33 MHz

GENERAL DESCRIPTION

The Z86C93 is a CMOS ROMless Z8 microcontroller enhanced with a hardwired 16-bit x 16-bit multiplier and 32-bit/16-bit divider and three 16-bit counter timers (Figure 1). A capture register and a fast decrement mode is also provided. It is offered in 40-pin PDIP, 44-pin PLCC, 44-pin QFP and 48-pin VQFP (Figures 2, 3, 4, 5 and 6). Besides the four additional signals (SCLK, IACK, /SYNC and /WAIT), the Z86C93 is compatible with the Z86C91, yet it offers a much more powerful mathematical capability.

The Z86C93 provides up to 16 output address lines permitting an address space of up to 64 Kbytes of data and program memory each. Eight address outputs (AD7-AD0) are provided by a multiplexed, 8-bit, Address/Data bus. The remaining 8 bits can be provided by the software configuration of Port 0 to output address bits A15-A8.

GENERAL DESCRIPTION (Continued)

There are 256 registers located on-chip and organized as 236 general-purpose registers, 16 control and status registers, and four I/O port registers. The register file can be divided into sixteen groups of 16 working registers each. Configuration of the registers in this manner allows the use of short format instructions; in addition, any of the individual registers can be accessed directly. There are an additional 17 registers implemented in the Expanded Register File in Banks D and E. Two of the registers may be used as general-purpose registers, while 15 registers supply the data and control functions for the Multiply/Divide Unit and Counter/Timer blocks.

Notes:

All Signals with a preceding front slash, "/", are active Low, e.g.: B//W (WORD is active Low); /B/W (BYTE is active Low, only).

Power connections follow conventional descriptions below:

Connection	Circuit	Device
Power	V_{CC}	V_{DD}
Ground	GND	V_{SS}

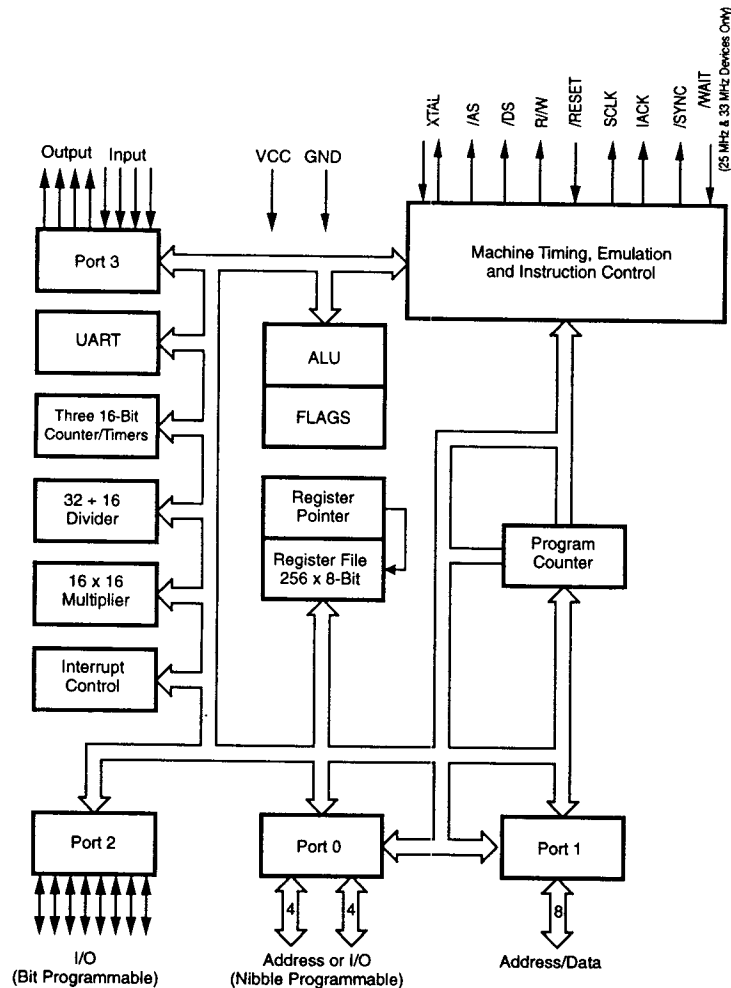

Figure 1. Functional Block Diagram

PIN DESCRIPTION

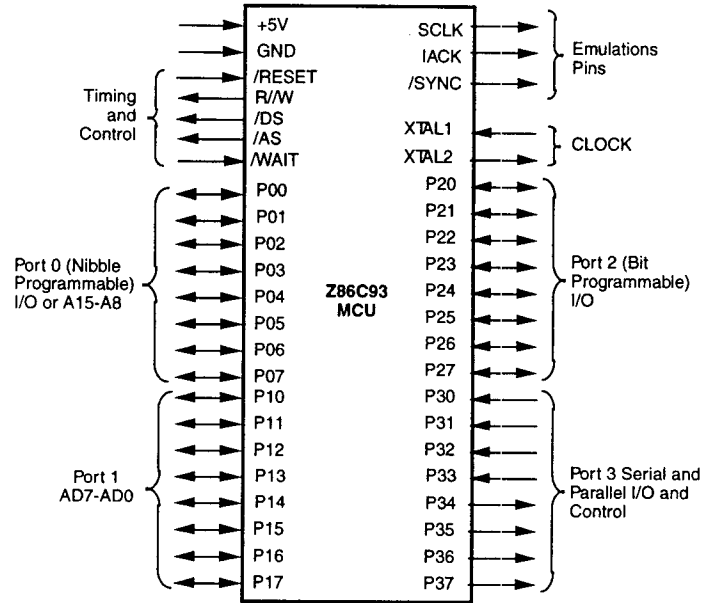

Figure 2. Pin Functions

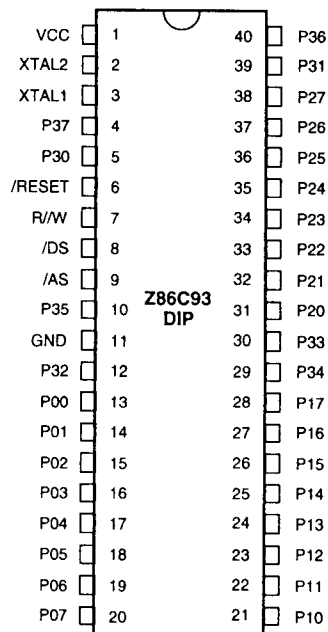

Figure 3. 40-Pin DIP

Table 1. 40-Pin DIP Pin Identification

Pin #	Symbol	Function	Direction
1	V _{CC}	Power Supply	Input
2	XTAL1	Crystal, Oscillator Clock	Input
3	XTAL2	Crystal, Oscillator Clock	Output
4	P37	Port 3 pin 7	Output
5	P30	Port 3 pin 0	Input
6	/RESET	Reset	Input
7	R/W	Read/Write	Output
8	/DS	Data Strobe	Output
9	/AS	Address Strobe	Output
10	P35	Port 3 pin 5	Output
11	GND	Ground, GND	Input
12	P32	Port 3 pin 2	Input
13-20	P00-P07	Port 0 pin 0,1,2,3,4,5,6,7	In/Output
21-28	P10-P17	Port 1 pin 0,1,2,3,4,5,6,7	In/Output
29	P34	Port 3 pin 4	Output
30	P33	Port 3 pin 3	Input
31-38	P20-P27	Port 2 pin 0,1,2,3,4,5,6,7	In/Output
39	P31	Port 3 pin 1	Input
40	P36	Port 3 pin 6	Output

PIN DESCRIPTION (Continued)

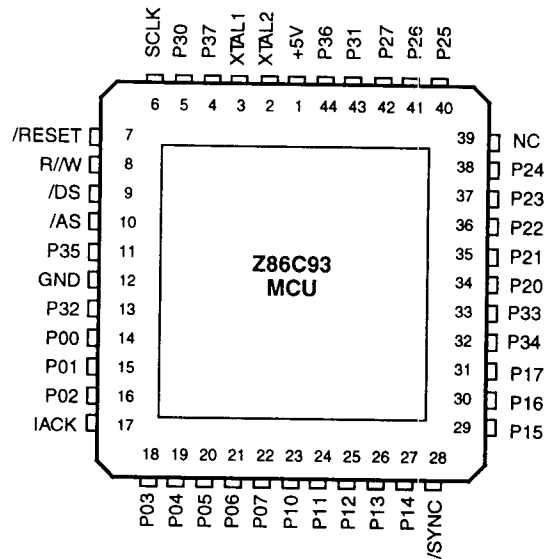

Figure 4. 44-Pin PLCC

Table 2. 44-Pin PLCC Pin Identification

No	Symbol	Function	Direction	No	Symbol	Function	Direction
1	V _{cc}	Power Supply	Input	14-16	P00-P02	Port 0 pin 0,1,2	In/Output
2	XTAL2	Crystal, Osc. Clock	Output	17	IACK	Int. Acknowledge	Output
3	XTAL1	Crystal, Osc. Clock	Input	18-22	P03-P07	Port 0 pin 3,4,5,6,7	In/Output
4	P37	Port 3 pin 7	Output	23-27	P10-P14	Port 1 pin 0,1,2,3,4	In/Output
5	P30	Port 3 pin 0	Input	28	/SYNC	Synchronize Pin	Output
6	SCLK	System Clock	Output	29-31	P15-P17	Port 1 pin 5,6,7	In/Output
7	/RESET	Reset	Input	32	P34	Port 3 pin 4	Output
8	R/W	Read/Write	Output	33	P33	Port 3 pin 3	Input
9	/DS	Data Strobe	Output	34-38	P20-P24	Port 2 pin 0,1,2,3,4	In/Output
10	/AS	Address Strobe	Output	39	N/C	Not Connected (20 MHz)	Input
11	P35	Port 3 pin 5	Output		/WAIT	WAIT (25 or 33 MHz)	Input
12	GND	Ground GND	Input	40-42	P25-P27	Port 2 pin 5,6,7	In/Output
13	P32	Port 3 pin 2	Input	43	P31	Port 3 pin 1	Input
				44	P36	Port 3 pin 6	Output

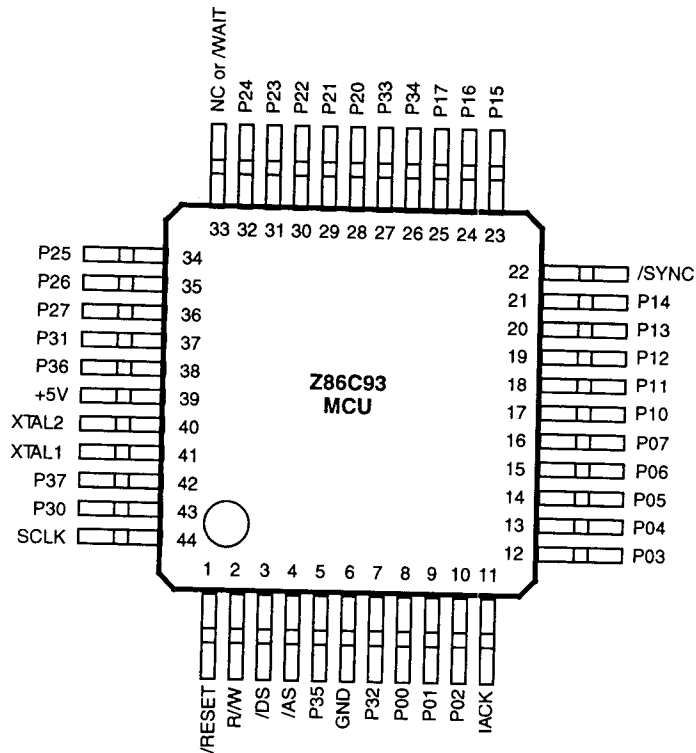

Figure 5. 44-Pin QFP

Table 3. 44-Pin QFP Pin Identification

No	Symbol	Function	Direction	No	Symbol	Function	Direction
1	/RESET	Reset	Input	26	P34	Port 3 pin 4	Output
2	R/W	Read/Write	Output	27	P33	Port 3 pin 3	Input
3	/DS	Data Strobe	Output	28-32	P2C-P24	Port 2 pin 0,1,2,3,4	In/Output
4	/AS	Address Strobe	Output	33	N/C /WAIT	Not Connected (20 MHz) WAIT (25 or 33 MHz)	Input Input
5	P35	Port 3 pin 5	Input	34-36	P25-P27	Port 2 pin 5,6,7	In/Output
6	GND	Ground GND	Input	37	P31	Port 3 pin 1	Input
7	P32	Port 3 pin 2	Input	38	P36	Port 3 pin 6	Output
8-10	P00-P02	Port 0 pin 0,1,2	In/Output	39	V _{cc}	Power Supply	Input
11	IACK	Int. Acknowledge	Output	40	XTAL2	Crystal, Osc. Clock	Output
12-16	P03-P07	Port 0 pin 3,4,5,6,7	In/Output	41	XTAL1	Crystal, Osc. Clock	Input
17-21	P10-P14	Port 1 pin 0,1,2,3,4	In/Output	42	P37	Port 3 pin 7	Output
22	/SYNC	Synchronize Pin	Output	43	P30	Port 3 pin 0	Input
23-25	P15-P17	Port 1 pin 5,6,7	In/Output	44	SCLK	System Clock	Output

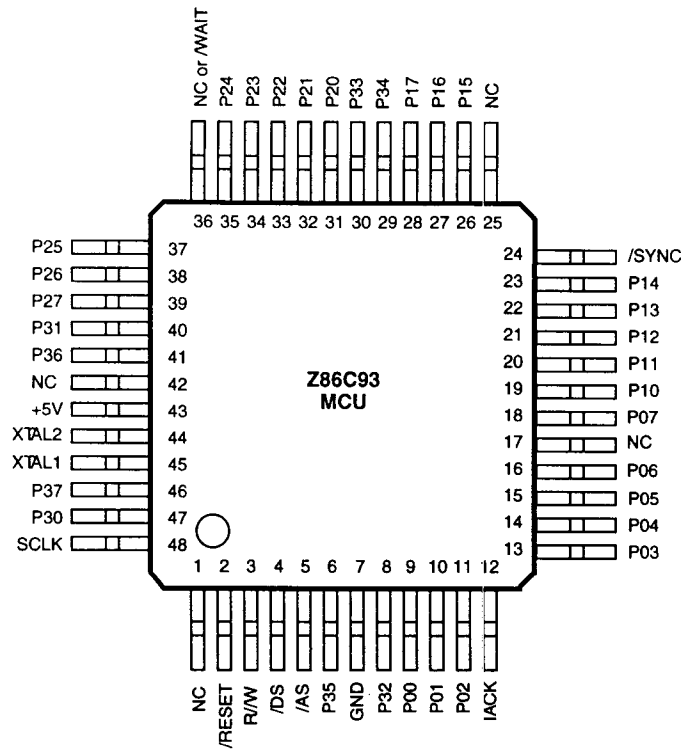

Figure 6. 48-Pin VQFP Package

Table 4. 48-Pin VQFP Pin Identification

No	Symbol	Function	Direction	No	Symbol	Function	Direction
1	N/C	Not Connected	Input	25	N/C	Not Connected	Input
2	/RESET	Reset	Input	26-28	P15-P17	Port 1 pin 5,6,7	In/Output
3	R/W	Read/Write	Output	29	F34	Port 3 pin 4	Output
4	/DS	Data Strobe	Output	30	F33	Port 3 pin 33	Input
5	/AS	Address Strobe	Output	31-35	P20-P24	Port 2 pin 0,1,2,3,4	In/Output
6	P35	Port 3 pin 5	Input	36	N/C	Not Connected (20 MHz)	Input
7	GND	Ground GND	Input		/WAIT	WAIT (25 or 33 MHz)	Input
8	P32	Port 3 pin 2	Input	37-39	P25-P27	Port 2 pin 5,6,7	In/Output
9-11	P00-P02	Port 0 pin 3,4,5,6	In/Output	40	F31	Port 3 pin 1	Input
12	IACK	Int. Acknowledge	Output	41	F36	Port 3 pin 6	Output
13-16	P03-P06	Port 0 pin 3,4,5,6	In/Output	42	N/C	Not Connected	Input
17	N/C	Not Connected	Input	43	V _{cc}	Power Supply	Input
18	P07	Port 0 pin 7	In/Output	44	XTAL2	Crystal, Osc. Clock	Output
19-23	P10-P14	Port 1 pin 0,1,2,3,4	In/Output	45	XTAL1	Crystal, Osc. Clock	Input
24	/SYNC	Synchronize Pin	Output	46	P37	Port 3 pin 7	Output
				47	F30	Port 3 pin 0	Input
				48	SCLK	System Clock	Output

PIN FUNCTIONS

/DS. (output, active Low). Data Strobe is activated once for each external memory transfer. For a READ operation, data must be available prior to the trailing edge of /DS. For WRITE operations, the falling edge of /DS indicates that output data is valid.

/AS. (output, active Low). Address Strobe is pulsed once at the beginning of each machine cycle. Address output is via Port 1 for all external programs. When /RESET is asserted, /AS toggles. Memory address transfers are valid at the trailing edge of /AS.

XTAL1, XTAL2. *Crystal 1, Crystal 2* (time-based input and output, respectively). These pins connect a parallel-resonant crystal, ceramic resonator, LC, or any external single-phase clock to the on-chip oscillator and buffer.

R/W. (output, read High/write Low). The Read/Write signal is Low when the MCU is writing to the external program or data memory. It is High when the MCU is reading from the external program or data memory.

/RESET. (input, active Low). To avoid asynchronous and noisy reset problems, the Z86C93 is equipped with a reset filter of four external clocks (4TpC). If the external /RESET signal is less than 4TpC in duration, no reset occurs.

On the 5th clock after the /RESET is detected, an internal RST signal is latched and held for an internal register count of 18 external clocks, or for the duration of the external /RESET, whichever is longer. During the reset cycle, /DS is held active Low while /AS cycles at a rate of 2TpC. When /RESET is deactivated, program execution begins at location 000CH. Reset time must be held Low for 50 ms or until V_{cc} is stable, whichever is longer.

SCLK. *System Clock* (output). The internal system clock is available at this pin. Available in the PLCC, QFP and VQFP packages only.

IACK. *Interrupt Acknowledge* (output, active High). This output, when High, indicates that the Z86C93 is in an interrupt cycle. Available in the PLCC, QFP and VQFP packages only.

/SYNC. (output, active Low). This signal indicates the last clock cycle of the currently executing instruction. Available in the PLCC, QFP and VQFP packages only.

/WAIT. (input, active Low). Introduces asynchronous wait states into the external memory fetch cycle. When this input goes Low during an external memory access, the Z86C93 freezes the fetch cycle until its pin goes High. This pin is sampled after /DS goes Low; should be pulled up if not used. Available in the 25 MHz and 33 MHz devices only.

Port 0 P00-P07. Port 0 is an 8-bit, nibble programmable, bidirectional, TTL compatible port. These eight I/O lines can be configured under software control as a nibble I/O port, or as an address port for interfacing external memory. When used as an I/O port, Port 0 may be placed under handshake control. In this configuration, Port 3, lines P32 and P35 are used as the handshake control /DAV0 and RDY0 (Data Available and Ready). Handshake signal assignment is dictated by the I/O direction of the upper nibble P04-P07. The lower nibble must have the same direction as the upper nibble to be under handshake control. Port 0 comes up as A15-A8 Address lines after /RESET.

For external memory references, Port 0 can provide address bits A11-A8 (lower nibble) or A15-A8 (lower and upper nibble) depending on the required address space. If the address range requires 12 bits or less, the upper nibble of Port 0 can be programmed independently as I/O while the lower nibble is used for addressing. If one or both nibbles are needed for I/O operation, they must be configured by writing to the Port 0 Mode register. After a hardware reset, Port 0 lines are defined as address lines A15-A8, and extended timing is set to accommodate slow memory access. The initialization routine can include reconfiguration to eliminate this extended timing mode (Figure 7). The /OEN (Output Enable) signal in Figure 7 is an internal signal.

The Auto Latch on Port 0 puts valid CMOS levels on all CMOS inputs which are not externally driven. Whether this level is 0 or 1, cannot be determined. A valid CMOS level, rather than a floating node, reduces excessive supply current flow in the input buffer.

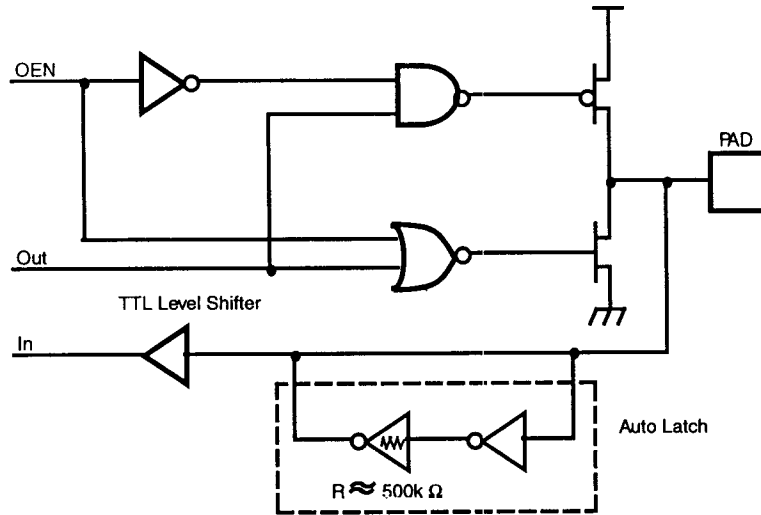
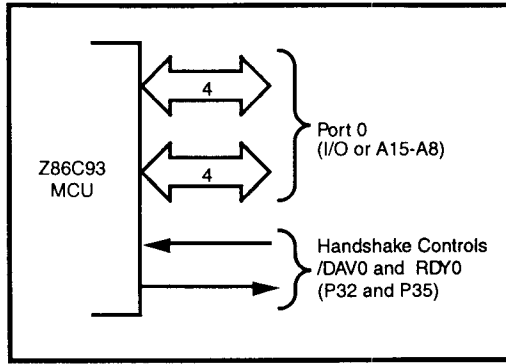

Figure 7. Port 0 Configuration

PIN FUNCTIONS (Continued)

Port 1. (P10-P17). Port 1 is an 8-bit, TTL compatible port. It has multiplexed Address (A7-A0) and Data (D7-D0) ports for interfacing external memory (Figure 8).

If more than 256 external locations are required, Port 0 must output the additional lines.

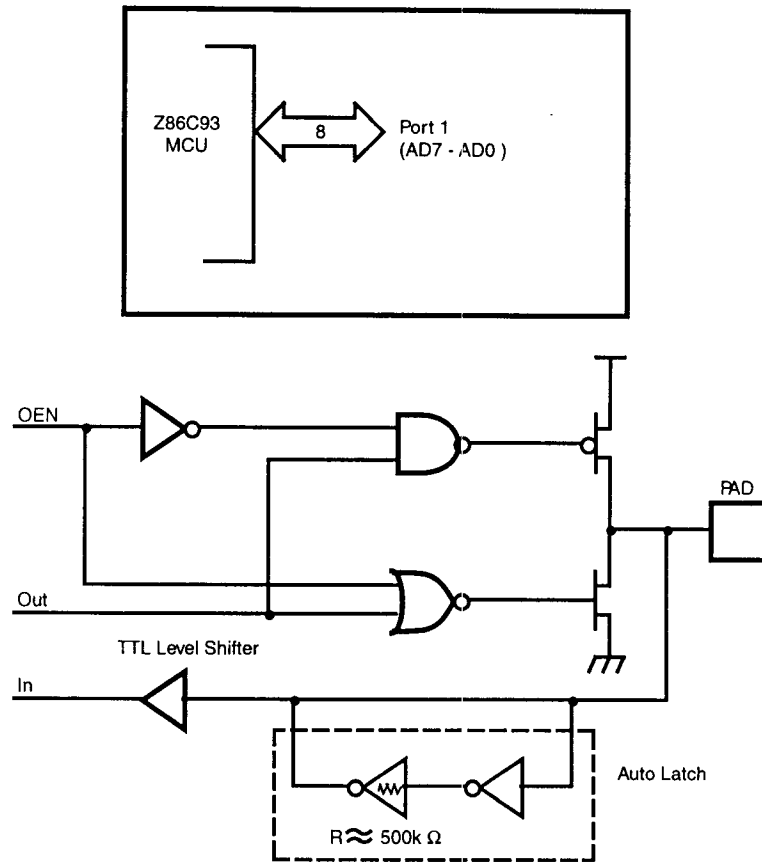

Figure 8. Port 1 Configuration

Port 2. (P20-P27). Port 2 is an 8-bit, bit programmable, bidirectional, TTL compatible port. Each of these eight I/O lines can be independently programmed as an input or output or globally as an open-drain output. Port 2 is always available for I/O operation. When used as an I/O port, Port 2 is placed under handshake control. In this configuration, Port 3 lines P31 and P36 are used as the handshake control lines /DAV2 and RDY2. The handshake signal

assignment for Port 3 lines P31 and P36 is dictated by the direction (input or output) assigned to P27 (Figure 9).

The Auto Latch on Port 2 puts valid CMOS levels on all CMOS inputs which are not externally driven. Whether this level is 0 or 1, cannot be determined. A valid CMOS level, rather than a floating node, reduces excessive supply current flow in the input buffer.

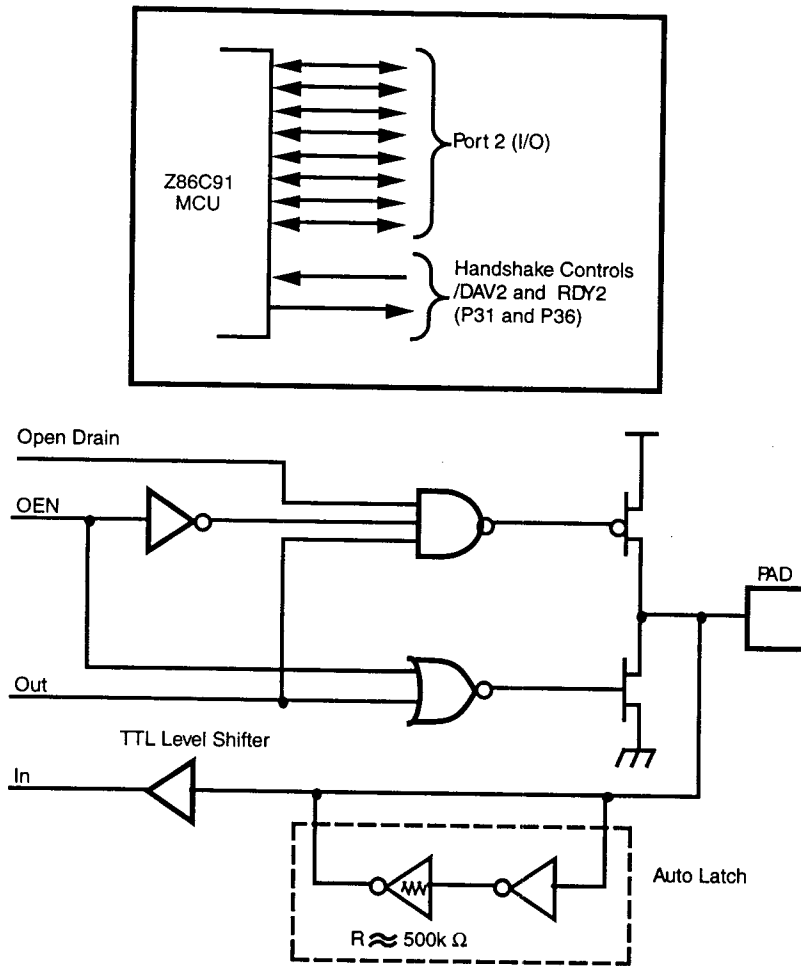

Figure 9. Port 2 Configuration

Port 3 P30-P37. Port 3 is an 8-bit, TTL compatible four fixed input and four fixed output ports. These eight I/O lines have four fixed (P30-P33) input and four fixed (P34-P37) output

ports. Port 3 pins P30 and P37 when used as serial I/O, are programmed as serial in and serial out, respectively (Figure 10 and Table 5).

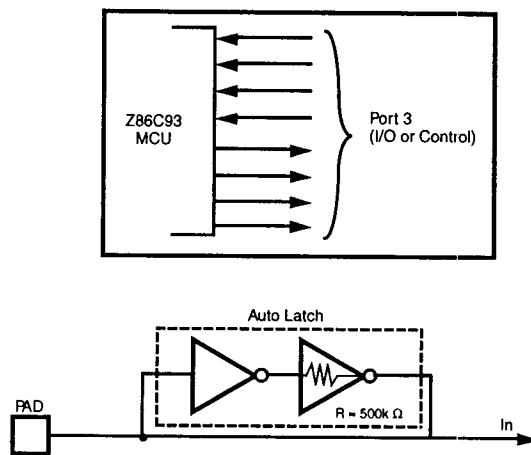

Figure 10. Port 3 Configuration

Table 5. Port 3 Pin Assignments

Pin #	I/O	CTC1	Int.	P0HS	P2HS	UART	Ext.
P30	In		IRQ3			Serial In	
P31	In	T_{IN}	IRQ2		D/R		
P32	In		IRQ0	D/R			
P33	In		IRQ1				
P34	Out						DM
P35	Out			R/D			
P36	Out	T_{OUT}			R/D		
P37	Out					Serial Out	

Port 3 is configured under software control to provide the following control functions: handshake for Ports 0 and 2 (/DAV and RDY); four external interrupt request signals (IRQ0-IRQ3); timer input and output signals (T_{IN} and T_{OUT}), and Data Memory Select (/DM).

Port 3 lines P30 and P37 can be programmed as serial I/O lines for full-duplex serial asynchronous receiver/transmitter operation. The bit rate is controlled by the Counter/Timer 0.

The Z86C93 automatically adds a start bit and two stop bits to transmitted data (Figure 10). Odd parity is also available as an option. Eight data bits are always transmitted,

regardless of parity selection. If parity is enabled, the eighth bit is the odd parity bit. An interrupt request (IRQ4) is generated on all transmitted characters.

Received data must have a start bit, eight data bits and at least one stop bit. If parity is on, bit 7 of the received data is replaced by a parity error flag. Received characters generate the IRQ3 interrupt request.

The Auto Latch on Port 3 puts a valid CMOS level on all CMOS inputs that are not externally driven. Whether this level is zero or one, cannot be determined. A valid CMOS level rather than a floating node reduces excessive supply current flow in the input buffer.

PIN FUNCTIONS (Continued)

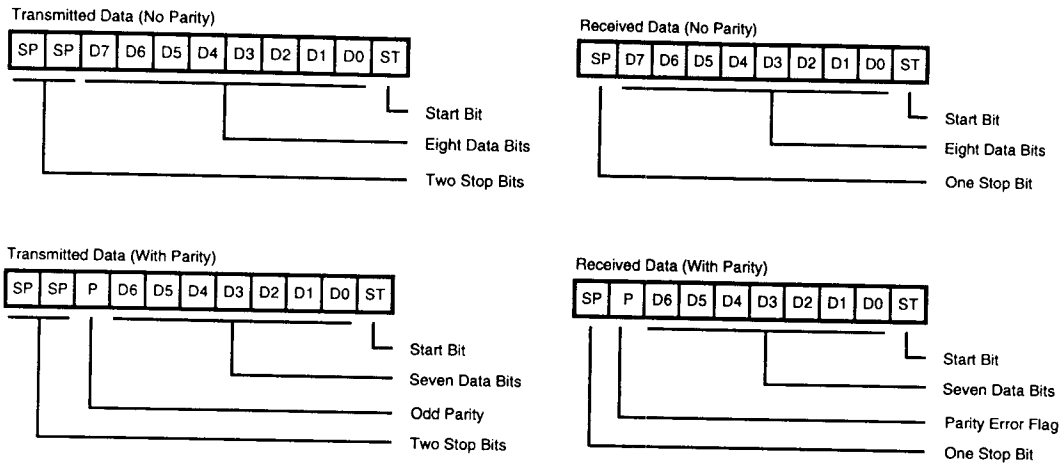

Figure 11. Serial Data Formats

ADDRESS SPACE

Program Memory. The Z86C93 can address up to 64 Kbytes of external program memory. Program execution begins at external location 000CH after a reset.

Data Memory. The Z96C93 can address up to 64 Kbytes of external data memory. External data memory is included with, or separated from, the external program memory

space. /DM, an optional I/O function that can be programmed to appear on pin P34 is used to distinguish between data and program memory space (Figure 12). The state of the /DM signal is controlled by the type instruction being executed. An LDC opcode references PROGRAM (/DM inactive) memory, and an LDE instruction references DATA (/DM active Low) memory.

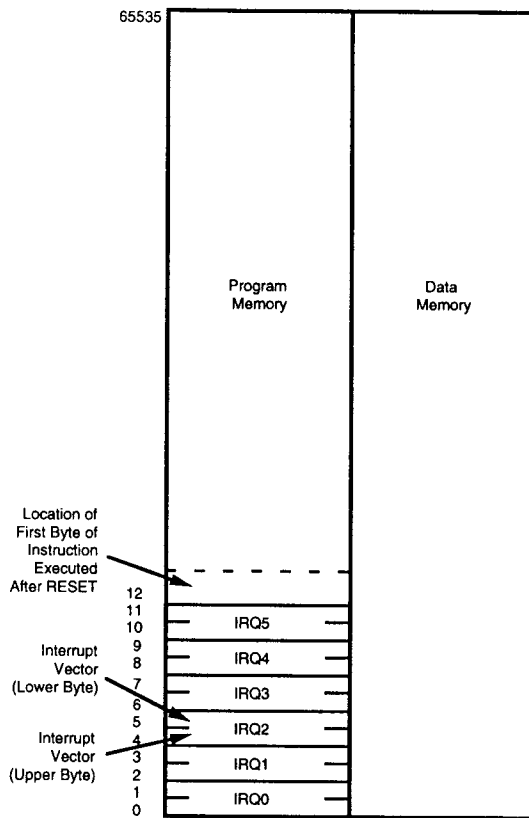

Figure 12. Program and Data Memory Configuration

Expanded Register File. The register file has been expanded to allow for additional system control registers, and for mapping of additional peripheral devices along with I/O ports into the register address area (Figure 13). The Z8 register address space R0 through R15 has now been implemented as 16 groups of 16 registers per group. These register groups are known as the ERF (Expanded Register File). Bits 7-4 of register RP select the working register group. Bits 3-0 of register RP select the expanded register group (Figure 14). The registers that are used in the multiply/divide unit reside in the Expanded Register File at Bank E and those for the additional timer control words reside in Bank D. The rest of the Expanded Register is not physically implemented and is open for future expansion.

Register File. The Register File consists of four I/O port registers, 236 general-purpose registers and 16 control

and status registers. The instructions can access registers directly or indirectly via an 8-bit address field. The Z86C93 also allows short 4-bit register addressing using the Register Pointer (Figure 15). In the 4-bit mode, the Register File is divided into 16 working register groups, each occupying 16 continuous locations. The Register Pointer addresses the starting location of the active working-register group.

Note: Register Group E0-EF can only be accessed through working registers and indirect addressing modes.

Stack. The Z86C93 has a 16-bit Stack Pointer (R254-R255), used for external stack, that resides anywhere in the data memory. An 8-bit Stack Pointer (R255) is used for the internal stack that resides within the 236 general-purpose registers (R4-R239). The high byte of the Stack Pointer (SPH, Bits 8-15) can be used as a general-purpose register when using internal stack only.

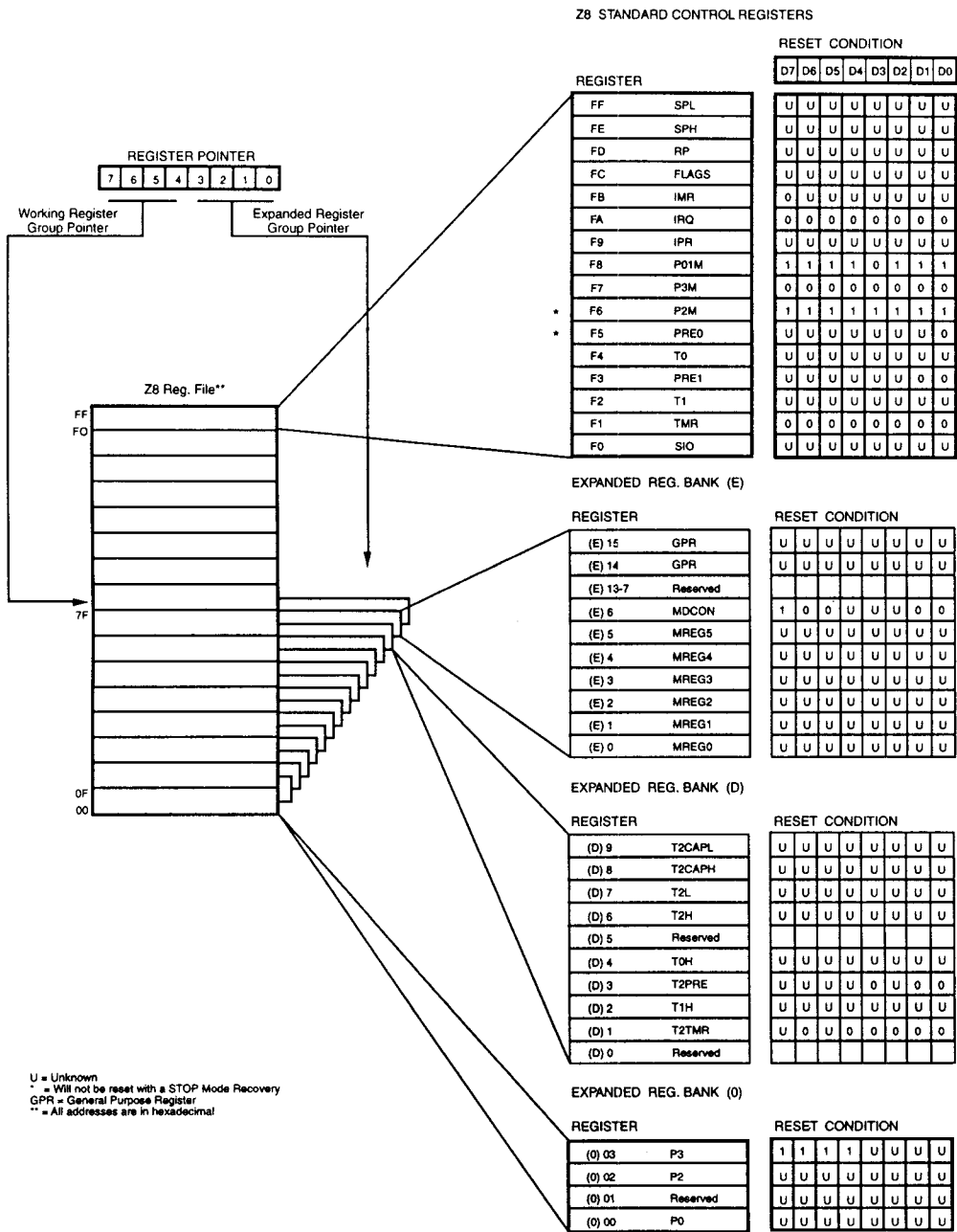

Figure 13. Register File

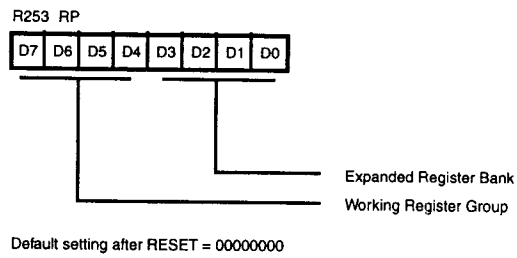

Figure 14. Register Pointer Register

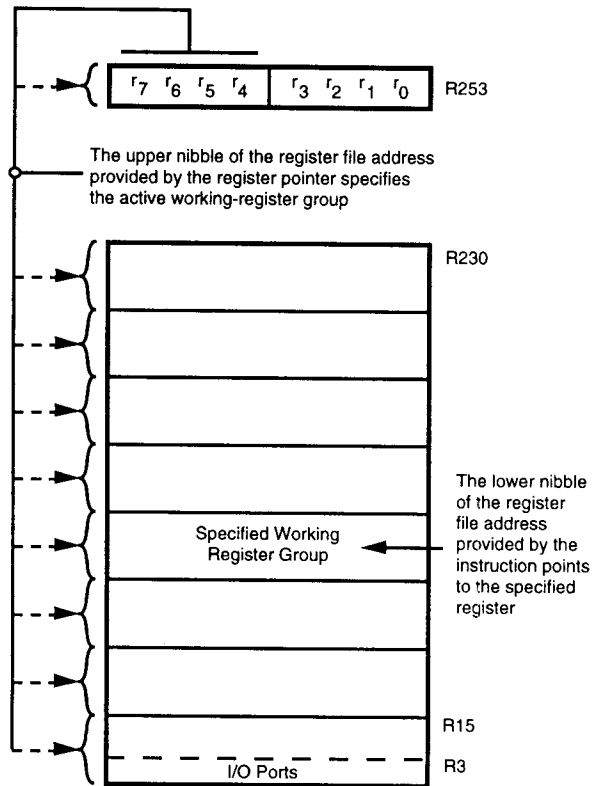

Figure 15. Register Pointer

FUNCTIONAL DESCRIPTION

This section breaks down the Z86C93 into its main functional parts.

Multiply/Divide Unit

The Multiply/Divide unit describes the basic features, implementation details of the interface between the Z8 and the multiply/divide unit.

Basic features:

- 16-bit by 16-bit multiply with 32-bit product
- 32-bit by 16-bit divide with 16-bit quotient and 16-bit remainder
- Unsigned integer data format
- Simple interface to Z8

Interface to Z8. The following is a brief description of the register mapping in the multiply/divide unit and its interface to the Z8 (Figure 16).

The multiply/divide unit is interfaced like a peripheral. The only addressing mode available with the peripheral interface is register addressing. In other words, all of the operands are in the respective registers before a multiplication/division can start.

Register mapping. The registers used in the multiply/divide unit are mapped onto the expanded register file in Bank E. The exact register locations used are shown below.

REGISTER	ADDRESS
MREG0	(E) 00
MREG1	(E) 01
MREG2	(E) 02
MREG3	(E) 03
MREG4	(E) 04
MREG5	(E) 05
MDCON	(E) 06
GPR	(E) 14
GPR	(E) 15

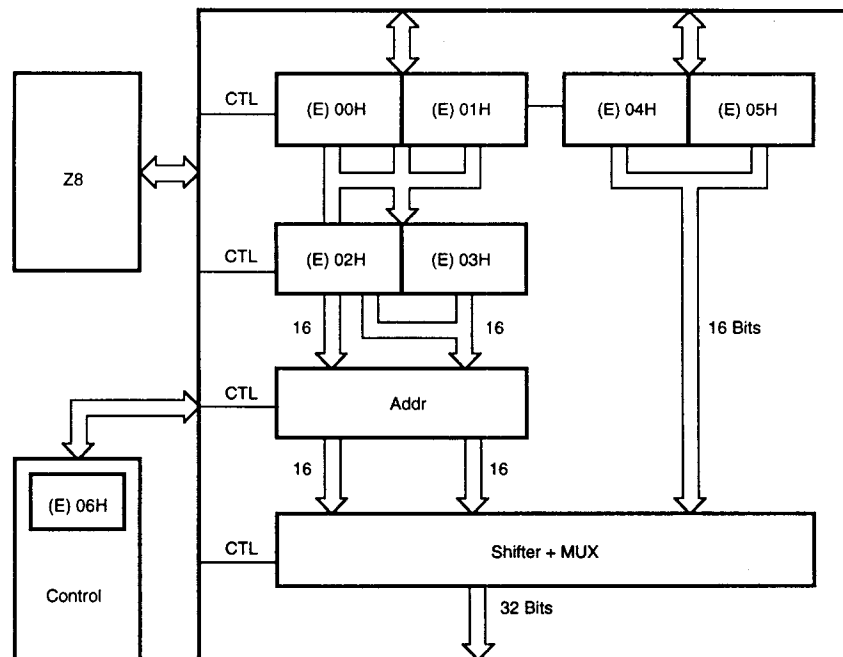

Figure 16. Multiply/Divide Unit Block Diagram

Register allocation. The following is the register allocation during multiplication.

Multiplier high byte	MREG2
Multiplier low byte	MREG3
Multiplicand high byte	MREG4
Multiplicand low byte	MREG5
Result high byte of high word	MREG0
Result low byte of high word	MREG1
Result high byte of low word	MREG2
Result low byte of low word	MREG3
Multiply/Divide Control register	MDCON

The following is the register allocation during division.

High byte of high word of dividend	MREG0
Low byte of high word of dividend	MREG1
High byte of low word of dividend	MREG2
Low byte of low word of dividend	MREG3
High byte of divisor	MREG4
Low byte of divisor	MREG5
High byte of remainder	MREG0
Low byte of remainder	MREG1
High byte of quotient	MREG2
Low byte of quotient	MREG3
Multiply/Divide Control register	MDCON

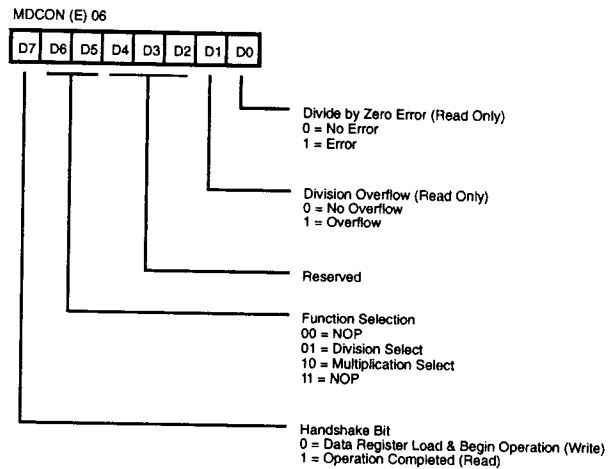

Figure 17. Multiply/Divide Control Register (MDCON)

Control register. The MDCON (Multiply/Divide Control Register) is used to interface with the multiply/divide unit (Figure 16). Specific functions of various bits in the control register are given below.

DONE bit (D7). This bit is a handshake bit between the math unit and the external world. On power up, this bit is set to 1 to indicate that the math unit has completed the previous operation and is ready to perform the next operation.

Before starting a new multiply/divide operation, this bit should be reset to 0 by the processor/programmer. This indicates that all the data registers have been loaded and the math unit can now begin a multiply/divide operation. During the process of multiplication or division, this bit is write-protected. Once the math unit completes its operation it sets this bit to indicate the completion of operation. The processor/programmer can then read the result.

MULSL. Multiply Select (D6). If this bit is set to 1, it indicates a multiply operation directive. Like the DONE bit, this bit is also write-protected during math unit operation and is reset to 0 by the math unit upon starting of the multiply/divide operation.

DIVSL. Division Select (D5). Similar to D6, D5 starts a division operation.

D4-D2. Reserved.

DIVOVF. Division Overflow (D1). This bit indicates an overflow during the division process. Division overflow occurs when the high word of the dividend is greater than or equal to the divisor. This bit is read only. When set to 1, it indicates overflow error.

FUNCTIONAL DESCRIPTION (Continued)

DIVZR. Division by Zero (D0). When set to 1, this indicates an error of division by 0. This bit is read only.

Example:

Upon reset, the status of the MDCON register is 100uuu00b (D7 to D0).

u = Undefined
x = Irrelevant
b = Binary

If multiplication operation is desired, the MDCON register is set to 010xxxxb.

If the MDCON register is READ during multiplication, it would have a value of 000uuu00b.

Upon completion of multiplication, the result of the MDCON register is 100uuu00b.

If division operation is desired, the MDCON register is set to 001xxxxb.

During division operation, the register would contain 000uu??b (? - value depends on the DIVIDEND, DIVISOR).

Upon completion of division operation, the MDCON register contains 100uuu??b.

Note that once the multiplication/division operation starts, all data registers (MREG5 through MREG0) are write-protected and so are the writable bits of the MDCON register. The write protection is released once the math unit operation is complete. However, the registers may be read at any time.

A multiplication sequence would look like:

1. Load multiplier and multiplicand.
2. Load MDCON register to start multiply operation.
3. Wait for the DONE bit of the MDCON register to be set to 1 and then read results.

Note that while the multiply/divide operation is in progress, the programmer can use the Z8 to do other things. Also, since the multiplication/division takes a fixed number of cycles, he can start reading the results before the DONE bit is set.

During a division operation, the error flag bits are set at the beginning of the division operation which means the flag bits can be checked by the Z8 while the division operation is being done.

The two general purpose registers can be used as scratch pad registers or as external data memory address pointers during an LDE instruction. MREG0 through MREG5, if not used for multiplication or division, can be used as general purpose registers.

Performance of multiplication. The actual multiplication takes 17 internal clock cycles. It is expected that the chip would run at a 10 MHz internal clock frequency (external clock divided by two). This results in an actual multiplication time (16-bit x 16-bit) of 1.7 μ s. If the time to load operands and read results is included:

Number of internal clock cycles to load 5 registers: 30
Number of internal clock cycles to read 4 registers: 24

The total internal clock cycles to perform a multiplication is 71. This results in a net multiplication time of 7.1 μ s. Note that this would be the worst case. This assumes that all of the operands are loaded from the external world as opposed to some of the operands being already in place as a result of a previous operation whose destination register is one of the math unit registers.

Performance of division. The actual division needs 20 internal clock cycles. This translates to 2.0 μ s for the actual division at 10 MHz (internal clock speed). If the time to load operands and read results is included:

Number of internal clock cycles to load operands: 42
Number of internal clock cycles to read results: 24

The total internal clock cycles to perform a division is 86. This translates to 8.6 μ s at 10 MHz.

Counter/Timers

This section describes the enhanced features of the counter/timers (CTC) on the Z86C93. It contains the register mapping of CTC registers and the bit functions of the newly added Timer2 control register.

In a standard Z8, there are two 8-bit programmable counter/timers (T0 and T1), each driven by its own 6-bit programmable prescaler. The T1 prescaler is driven by internal or external clock sources; however, the T0 prescaler is driven by the internal clock only.

The 6-bit prescalers divide the input frequency of the clock source by any integer number from 1 to 64. Each prescaler drives its counter, which decrements the value (1 to 256) that has been loaded into the counter. When the counter reaches the end of the count, a timer interrupt request IRQ4 (T0) or IRQ5 (T1), is generated.

The counters are programmed to start, stop, restart to continue, or restart from the initial value. The counters can also be programmed to stop upon reaching zero (single pass mode) or to automatically reload the initial value and continue counting (modulo-n continuous mode).

The counters, but not the prescalers, are read at any time without disturbing their value or count mode. The clock source for T1 is user-definable and is either the internal microprocessor clock divided by four, or an external signal input via Port 3. The Timer Mode register configures the external timer input (P31) as an external clock, a trigger input that is retriggerable or non-retriggerable, or as a gate input for the internal clock. The counter/timers are cascaded by connecting the T0 output to the input of T1. Either T0 or T1 can be outputted via P36.

The following are the enhancements made to the counter/timer block on the Z86C93 (Figure 18):

- T0 counter length is extended to 16 bits. For example, T0 now has a 6-bit prescaler and 16-bit down counter.
- T1 counter length is extended to 16 bits. For example, T1 now has a 6-bit prescaler and 16-bit down counter.
- A new counter/timer T2 is added. T2 has a 4-bit prescaler and a 16-bit down counter with capture register.

These three counters are cascadable as shown in Table 6. The result is that T2 may be extendable to 32 bits and T1 extendable to 24 bits. Bits 1 and 0 (CAS1 AND CAS0) of the T2 Prescaler Register (PRE2) determine the counter length.

Table 6. Counter Length Configurations

CAS 1	CAS 0	T0	T1	T2
0	0	8	8	32
0	1	16	16	16
1	0	8	24	16
1	1	8	16	24

The controlling clock input to T2 is programmed to XTAL/2 or XTAL/8 (only when T2 counter length is 16 bits), which results in a resolution of 100 ns at an external XTAL clock speed of 20 MHz.

Capture Register. T2 has a 16-bit capture register associated with T2 HIGH BYTE and T2 LOW BYTE registers. The negative going transition on pin P33 enables the latching of the current T2 value (16 bits) into the capture register. The register mapping of the capture register is in Bank D (Figure 13). Note that the negative transition on P33 is capable of generating an interrupt. Also, the negative transition on P33 always latches the current T2 value into the capture register. There is no need for a control bit to enable/disable the latching; the capture register is read only.

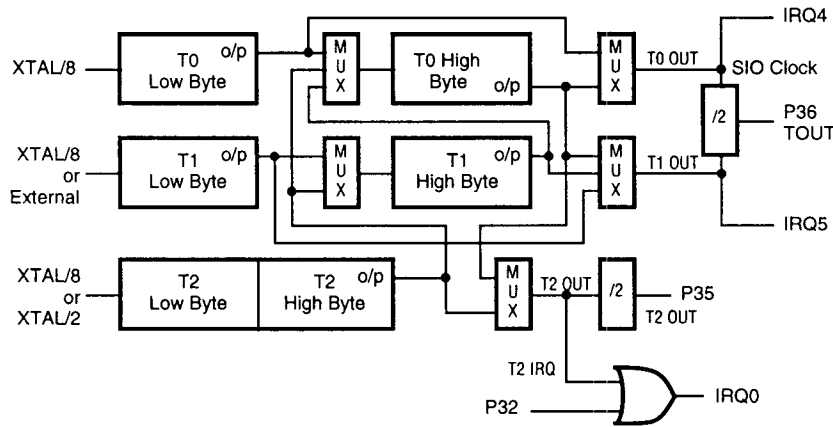

Figure 18. Counter/Timer Block Diagram

FUNCTIONAL DESCRIPTION (Continued)

Operation

Except for the programmable down counter length and clock input, T2 is identical to T0.

T0 and T1 retain all their features except that now they are extendable interims of the down-counter length.

The output of T2, under program control, goes to an output pin (P35). Also, the interrupt generated by T2 is ORed with the interrupt request generated by P32. Note that the service routine then has to poll the T2 flag bit and also clear it (Bit 7 of T2 Timer Mode Register).

On power up, T0 and T1 are configured in the 8-bit down counter length mode (to be compatible with Z86C91) and T2 is in the 32-bit mode with its output disabled (no interrupt is generated and T2 output DOES NOT go to port pin P35).

The UART uses T0 for generating the bit clock. This means, while using UART, T0 should be in 8-bit mode. So, while using the UART there are only two independent timer/counters.

The counters are configured in the following manner:

Timer	Mode	Byte
T0	8-bit	Low Byte (T0)
T0	16-bit	High Byte (T0) + Low Byte (T0)
T1	8-bit	Low Byte (T1)
T1	16-bit	High Byte (T1) + Low Byte (T1)
T1	24-bit	High Byte (T0) + High Byte (T1) + Low Byte (T1)
T2	16-bit	High Byte (T2) + Low Byte (T2)
T2	24-bit	High Byte (T0) + High Byte (T2) + Low Byte (T2)
T2	32-bit	High Byte (T0) + High Byte (T1) + High Byte (T2) + Low Byte (T2)

Note that the T2 interrupt is logically ORed with P32 to generate IRQ0.

The T2 Timer Mode register is shown in Figure 19. Upon reaching end of count, bit 7 of this register is set to one. This bit IS NOT reset in hardware and it has to be cleared by the interrupt service routine.

T2 interrogates the state of the Count Mode Bit (D2) once it has counted down to its zero value. T2 then makes the decision to continue counting (Module N Mode) or stop (Single Pass Mode). Observe this functionality if attempting to modify the count mode prior to the end of count bit (D7) being set.

The register map of the new CTC registers is shown in Figure 13. T0 high byte and T1 high byte are at the same relative locations as their respective low bytes, but in a different register bank.

The T2 prescaler register is shown in Figure 19. Bits 1 and 0 of this register control the various cascade modes of the counters.

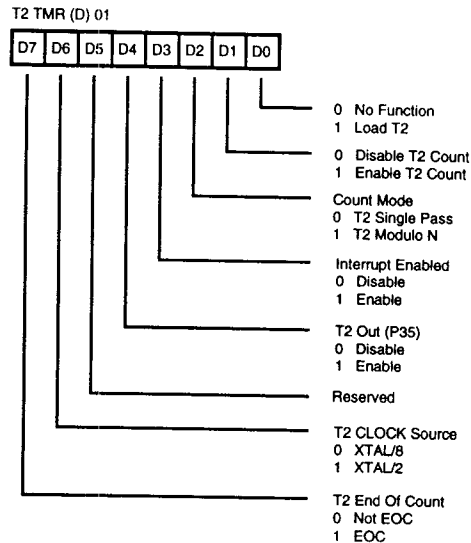

Figure 19. T2 Timer Mode Register (T2)

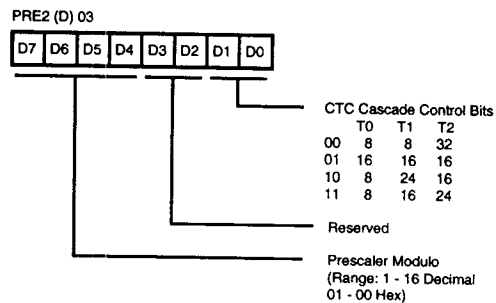

Figure 20. T2 Prescaler Register (PRE2)

Interrupts

The Z86C93 has six different interrupts from nine different sources. The interrupts are maskable and prioritized. The nine sources are divided as follow: four sources are claimed by Port 3 lines P30-P33, one in Serial Out, one in Serial In, and three in the counter/timers. The Interrupt Mask Register globally or individually enables or disables the six interrupt requests. When more than one interrupt is pending, priorities are resolved by a programmable priority encoder that is controlled by the Interrupt Priority register. All Z86C93 interrupts are vectored through locations in the program memory. When an interrupt machine cycle is activated an interrupt request is granted. Thus, this disables all of the subsequent interrupts, save the Program Counter and Status Flags, and then branches to the program memory vector location reserved for that interrupt. This memory location and the next byte contain the 16-bit address of the interrupt service routine for that particular interrupt request.

Internal interrupt requests are sampled on the falling edge of the last cycle of every instruction. The interrupt request must be valid 5TpC before the falling edge of the last clock cycle of the currently executing instruction.

When the device samples a valid interrupt request, the next 48 (external) clock cycles are used to prioritize the interrupt, and push the two PC bytes and the FLAG register on the stack. The following nine cycles are used to fetch the interrupt vector from external memory. The first byte of the interrupt service routine is fetched beginning on the 58th TpC cycle following the internal sample point, which corresponds to the 63rd TpC cycle following the external interrupt sample point.

To accommodate polled interrupt systems, interrupt inputs are masked and the Interrupt Request register is polled to determine which of the interrupt requests need service. Software initiated interrupts are supported by setting the appropriate bit in the Interrupt Request Register (IRQ).

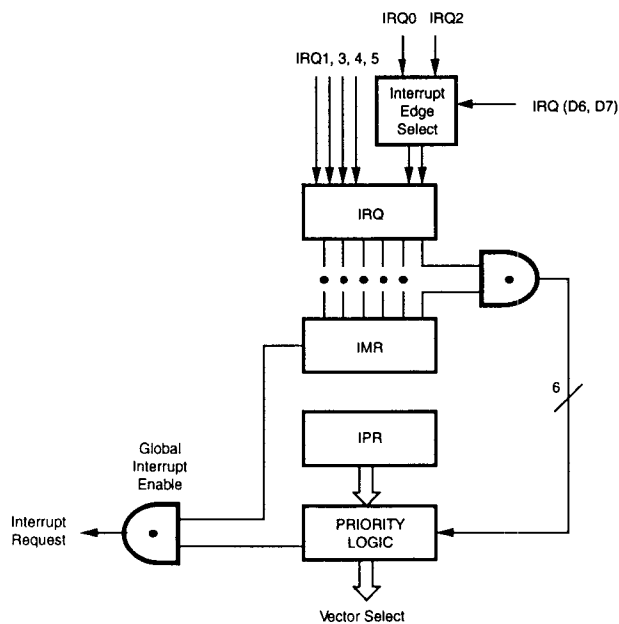

Figure 21. Interrupt Block Diagram

Table 7. Interrupt Types, Sources, and Vectors

Name	Source	Vector Location	Comments
IRQ 0	/DAV 0, P32, T2	0, 1	External (P32), Programmable Rise or Fall Edge Triggered
IRQ 1,	P33	2, 3	External (P33), Fall Edge Triggered
IRQ 2	/DAV 2, P31, T _{IN}	4, 5	External (P31), Programmable Rise or Fall Edge Triggered
IRQ 3	P30, Serial In	6, 7	External (P30), Fall Edge Triggered
IRQ 4	T0, Serial Out	8, 9	Internal
IRQ 5	T1	10, 11	Internal

Clock

The Z86C93 on-chip oscillator has a high-gain, parallel-resonant amplifier for connection to a crystal, LC, ceramic resonator, or any suitable external clock source (XTAL1=Input, XTAL2=Output). The external clock levels

are not TTL. The crystal should be AT cut, 1 MHz to 25 MHz max, and series resistance (RS) is less than or equal to 100 Ohms. The crystal should be connected across XTAL1 and XTAL2 using the recommended capacitors (10 pF < CL < 100 pF) from each pin to ground (Figure 20).

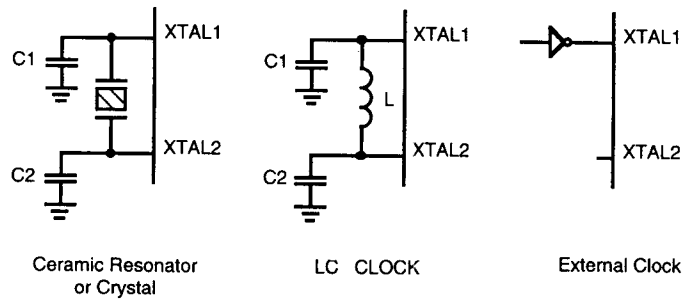

Figure 22. Oscillator Configuration

Power Down Modes

HALT. Turns off the internal CPU clock but not the XTAL oscillation. The counter/timers and the external interrupts IRQ0, IRQ1, IRQ2 and IRQ3 remain active. The devices are recovered by interrupts, either externally or internally generated. During HALT mode, /DS, /AS and R/W are HIGH. The outputs retain their preview value, and the inputs are floating.

STOP. This instruction turns off the internal clock and external crystal oscillation and reduces the standby current to 10 μ A or less. The STOP mode is terminated by a /RESET, which causes the processor to restart the application program at address 000CH.

In order to enter STOP (or HALT) mode, it is necessary to first flush the instruction pipeline to avoid suspending execution in mid-instruction. To do this, the user executes a NOP (opcode=OFFH) immediately before the appropriate sleep instruction, i.e.:

```
FF NOP ; clear the pipeline
6F STOP ; enter STOP mode
or
FF NOP ; clear the pipeline
7F HALT ; enter HALT mode
```

ABSOLUTE MAXIMUM RATINGS

Symbol	Description	Min	Max	Units
V_{CC}	Supply Voltage*	-0.3	+7.0	V
T_{STG}	Storage Temp	-65	+150	C
T_A	Oper Ambient Temp	†	†	C

* Voltages on all pins with respect to GND.
 † See Ordering Information

Stress greater than those listed under Absolute Maximum Ratings may cause permanent damage to the device. This is a stress rating only; operation of the device at any condition above those indicated in the operational sections of these specifications is not implied. Exposure to absolute maximum rating conditions for an extended period may affect device reliability.

STANDARD TEST CONDITIONS

The characteristics listed below apply for standard test conditions as noted. All voltages are referenced to GND. Positive current flows into the referenced pin Test Load Diagram (Figure 23).

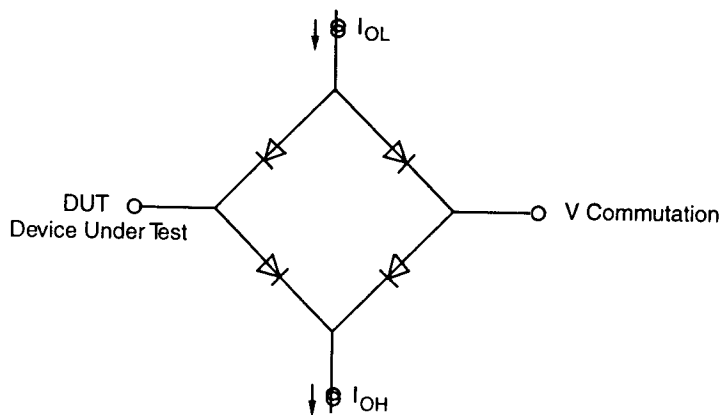

Figure 23. Test Load Diagram

DC ELECTRICAL CHARACTERISTICS

$$V_{CC} = 3.3V \pm 10\%$$

Sym	Parameter	$T_A = 0^\circ\text{C to } +70^\circ\text{C}$		Typical at 25°C	Units	Conditions
		Min	Max			
	Max Input Voltage		7		V	
V_{CH}	Clock Input High Voltage	$0.8 V_{CC}$	V_{CC}		V	$I_{IN} = 250 \mu\text{A}$ Driven by External Clock Generator
V_{CL}	Clock Input Low Voltage	-0.03	$0.1 \times V_{CC}$		V	Driven by External Clock Generator
V_{IH}	Input High Voltage	$0.7 \times V_{CC}$	V_{CC}		V	
V_{IL}	Input Low Voltage	-0.3	$0.1 \times V_{CC}$		V	
V_{OH}	Output High Voltage	1.8			V	$I_{OH} = -1.0 \text{ mA}$
V_{OH}	Output High Voltage	$V_{CC} - 100\text{mV}$			V	$I_{OH} = -100 \mu\text{A}$
V_{OL}	Output Low Voltage		0.4		V	$I_{OL} = +1.0 \text{ mA}$
V_{RH}	Reset Input High Voltage	$0.8 \times V_{CC}$	V_{CC}		V	
V_{RL}	Reset Input Low Voltage	-0.03	$0.1 \times V_{CC}$		V	
I_{IL}	Input Leakage	-2	2		μA	Test at 0V, V_{CC}
I_{OL}	Output Leakage	-2	2		μA	Test at 0V, V_{CC}
I_{IR}	Reset Input Current		-80		μA	$V_{RL} = 0\text{V}$
I_{CC}	Supply Current		30	20	mA	@ 25 MHz [1]
I_{CC1}	Stand By Current (HALT Mode)		12	8	mA	HALT Mode $V_{IN} = 0\text{V}$, V_{CC} @ 25 MHz [1]
I_{CC2}	Stand By Current (HALT Mode)		8	1	μA	STOP Mode $V_{IN} = 0\text{V}$, V_{CC} [1]
I_{AL}	Auto Latch Low Current	-10	10	5	μA	

Note:

[1] All inputs driven to 0V, V_{CC} and outputs floating.

DC ELECTRICAL CHARACTERISTICS

$V_{CC} = 5.0V \pm 10\%$

Sym	Parameter	$T_A = 0^\circ\text{C to } +70^\circ\text{C}$		Typical at 25°C	Units	Conditions
		Min	Max			
	Max Input Voltage		7		V	
V_{CH}	Clock Input High Voltage	3.8	V_{CC}		V	$I_{IN} = 250 \mu\text{A}$ Driven by External Clock Generator
V_{CL}	Clock Input Low Voltage	-0.03	0.8		V	Driven by External Clock Generator
V_{IH}	Input High Voltage	2.0	V_{CC}		V	
V_{IL}	Input Low Voltage	-0.3	0.8		V	
V_{OH}	Output High Voltage	2.4			V	$I_{OH} = -2.0 \text{ mA}$
V_{OH}	Output High Voltage	$V_{CC} - 100\text{mV}$			V	$I_{OH} = -100 \mu\text{A}$
V_{OL}	Output Low Voltage		0.4		V	$I_{OL} = +5 \text{ mA}$
V_{RH}	Reset Input High Voltage	3.8	V_{CC}		V	
V_{RL}	Reset Input Low Voltage	-0.03	0.8		V	
I_{IL}	Input Leakage	-2	2		μA	Test at 0V, V_{CC}
I_{OL}	Output Leakage	-2	2		μA	Test at 0V, V_{CC}
I_{IR}	Reset Input Current		-80		μA	$V_{RL} = 0V$
I_{CC}	Supply Current		55	35	mA	@ 33 MHz [1]
			40	25	mA	@ 25 MHz [1]
			30	20	mA	@ 20 MHz [1]
I_{CC1}	Standby Current (HALT Mode)		15	9	mA	HALT Mode $V_{IN} = 0V, V_{CC}$ @ 25 MHz [1]
			20	15		HALT Mode $V_{IN} = 0V, V_{CC}$ @ 33 MHz [1]
			12	7	mA	HALT Mode $V_{IN} = 0V, V_{CC}$ @ 20 MHz [1]
I_{CC2}	Standby Current (STOP Mode)		10	1	μA	STOP Mode $V_{IN} = 0V, V_{CC}$ [1]
I_{AL}	Auto Latch Current	-16	16	5	μA	

Note:

[1] All inputs driven to 0V, or V_{CC} and outputs floating.

AC CHARACTERISTICS

External I/O or Memory Read/Write Timing Diagram

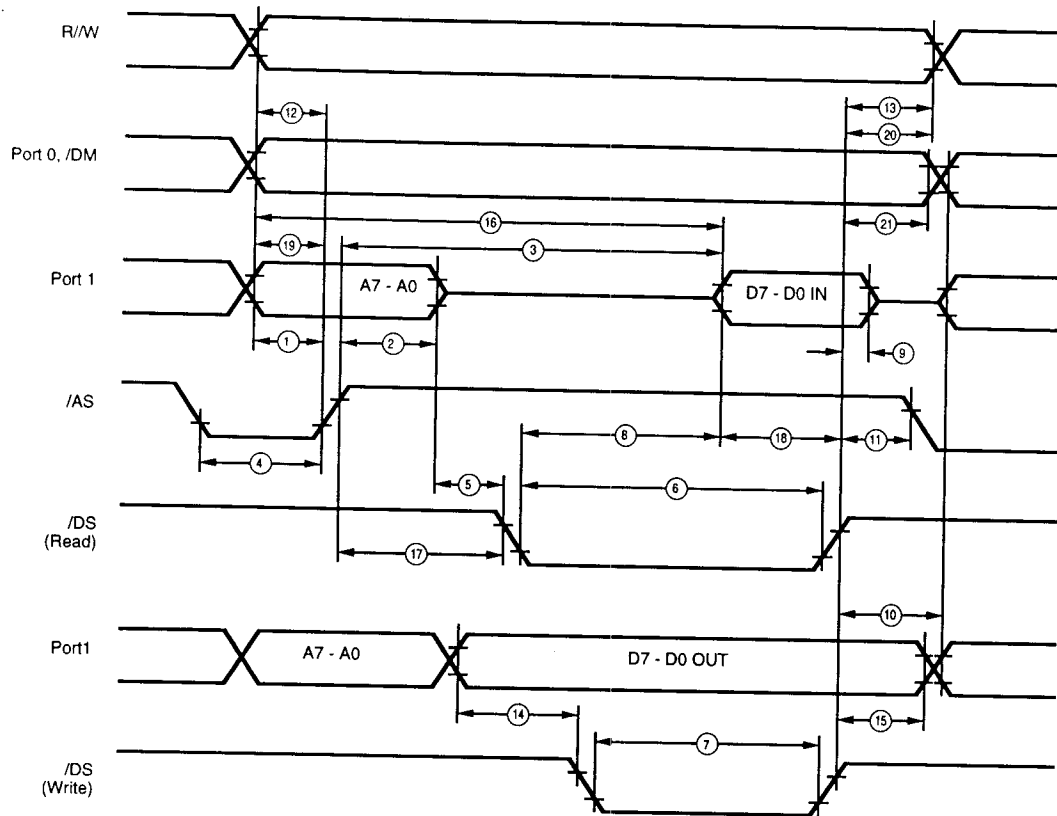

Figure 24. External I/O or Memory Read/Write Timing

AC CHARACTERISTICS

External I/O or Memory Read and Write; DSR/DSW; WAIT Timing Table

No	Sym	Parameter	$T_A = 0^\circ\text{C to } +70^\circ\text{C}$						Units
			33 MHz		25 MHz		20 MHz		
			Min	Max	Min	Max	Min	Max	
1	TdA(AS)	Address Valid To /AS Rise Delay	13		22		26		ns
2	TdAS(A)	/AS Rise To Address Hold Time	20		25		28		ns
3	TdAS(DI)	/AS Rise Data In Req'd Valid Delay		90		130		160	ns
4	TwAS	/AS Low Width	20		28		36		ns
5	TdAZ(DSR)	Address Float To /DS (Read)	0		0		0		ns
6	TwDSR	/DS (Read) Low Width	65		100		130		ns
7	TwDSW	/DS (Write) Low Width	40		65		75		ns
8	TdDSR(DI)	/DS (Read) To Data In Req'd Valid Delay		30		78		100	ns
9	ThDSR(DI)	/DS Rise (Read) to Data In Hold Time	0		0		0		ns
10	TdDS(A)	/DS Rise To Address Active Delay	25		34		40		ns
11	TdDS(AS)	/DS Rise To /AS Delay	16		30		36		ns
12	TdR/W(AS)	R/W To /AS Rise Delay	12		26		32		ns
13	TdDS(R/W)	/DS Rise To R/W Valid Delay	12		30		36		ns
14	TdDO(DSW)	Data Out To /DS (Write) Delay	12		34		40		ns
15	ThDSW(DO)	/DS Rise (Write) To Data Out Hold Time	12		34		40		ns
16	TdA(DI)	Address To Data In Req'd Valid Delay		110		160		200	ns
17	TdAS(DSR)	/AS Rise To /DS (Read) Delay	20		40		48		ns
18	TaDI(DSR)	Data In Set-up Time To /DS Rise Read	16		30		36		ns
19	TdDM(AS)	/DM To /AS Rise Delay	10		22		26		ns
20	TdDS(DM)	/DS Rise To /DM Valid Delay						34*	ns
21	ThDS(A)	/DS Rise To Address Valid Hold Time						34*	ns
22	TdXT(SCR)	XTAL Falling to SCLK Rising						20*	ns
23	TdXT(SCF)	XTAL Falling to SCLK Falling						23*	ns
24	TdXT(DSRF)	XTAL Falling to /DS Read Falling						29*	ns
25	TdXT(DSRR)	XTAL Falling to /DS Read Rising						29*	ns
26	TdXT(DSWF)	XTAL Falling to /DS Write Falling						29*	ns
27	TdXT(DSWF)	XTAL Falling to /DS Write Rising						29*	ns
28	TsW(XT)	Wait Set-up Time						10*	ns
29	ThW(XT)	Wait Hold Time						15*	ns
30	TwW	Wait Width (One Wait Time)						25*	ns

Notes:

When using extended memory timing add 2 TpC.
Timing numbers given are for minimum TpC.

* Preliminary value to be characterized.

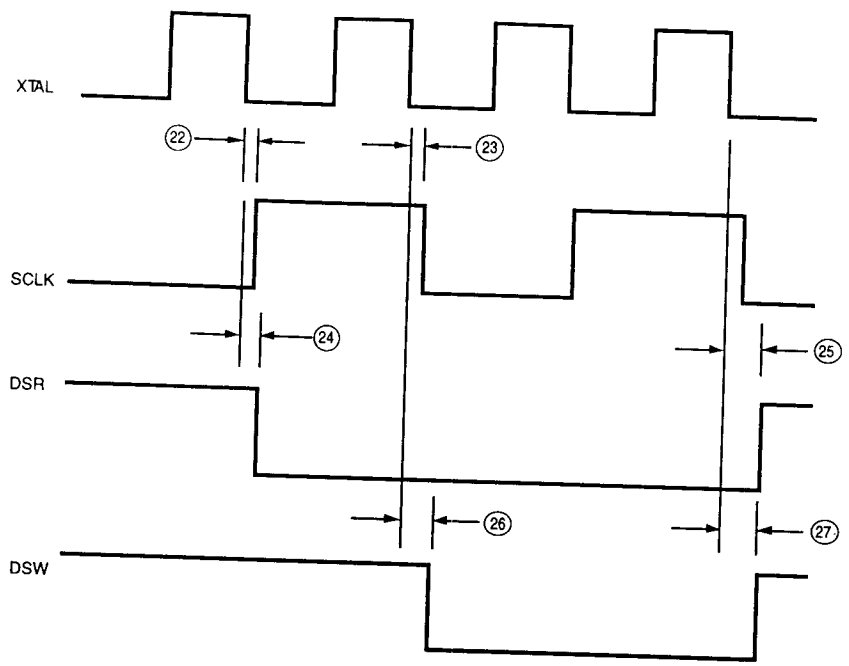

Figure 25. XTAL/SCLK To DSR and DSW Timing

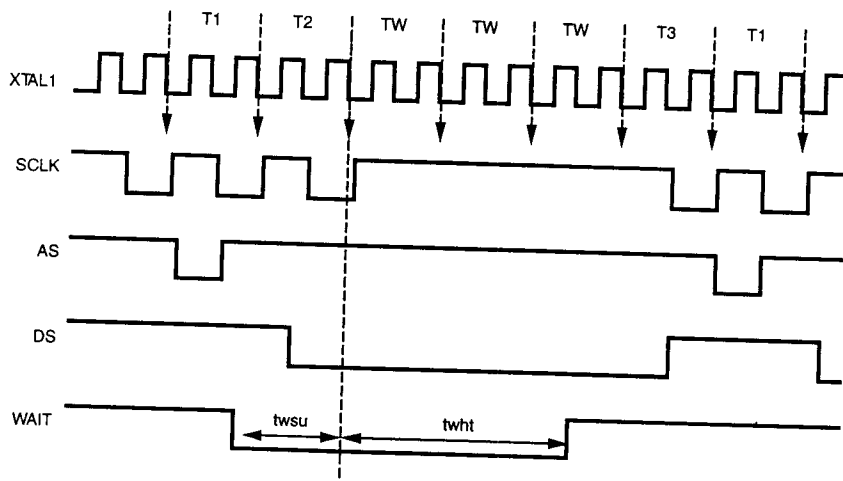

Figure 26. XTAL/SCLK To WAIT Timing
(25 MHz Device Only)

AC CHARACTERISTICS
Additional Timing Diagram

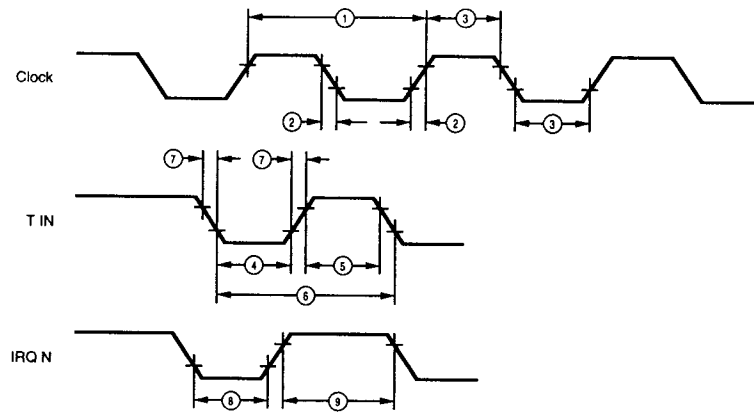

Figure 27. Additional Timing

AC CHARACTERISTICS
Additional Timing Table

No	Symbol	Parameter	$T_A = 0^\circ\text{C to } +70^\circ\text{C}$				Units	Notes		
			33 MHz		24 MHz				20 MHz	
			Min	Max	Min	Max	Min	Max		
1	TpC	Input Clock Period	30	1000	42	1000	50	1000	ns	[1]
2	TrC, TFC	Clock Input Rise & Fall Times		5		10		10	ns	[1]
3	TwC	Input Clock Width	10		11		15		ns	[1]
4	TwTinL	Timer Input Low Width	75		75		75		ns	[2]
5	TwTinH	Timer Input High Width	3TpC		3TpC		3TpC			[2]
6	TpTin	Timer Input Period	8TpC		8TpC		8TpC			[2]
7	TrTin, TtTin	Timer Input Rise & Fall Times	100		100		100		ns	[2]
8A	TwIL	Interrupt Request Input Low Times	70		70		70		ns	[2,4]
8B	TwIH	Interrupt Request Input High Times	5TpC		5TpC		5TpC			[2,5]
9	TwIH	Interrupt Request Input High Times	3TpC		3TpC		3TpC			[2,3]

Notes:

- [1] Clock timing references use 3.8V for a logic 1 and 0.8V for a logic 0.
- [2] Timing references use 2.0V for a logic 1 and 0.8V for a logic 0.
- [3] Interrupt references request via Port 3.
- [4] Interrupt request via Port 3 (P31-P33).
- [5] Interrupt request via Port 30.

AC CHARACTERISTICS
Handshake Timing Diagrams

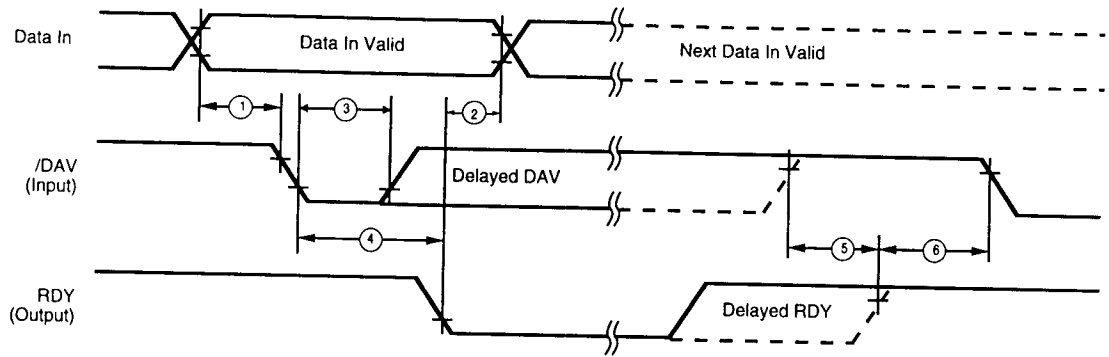

Figure 28. Input Handshake Timing

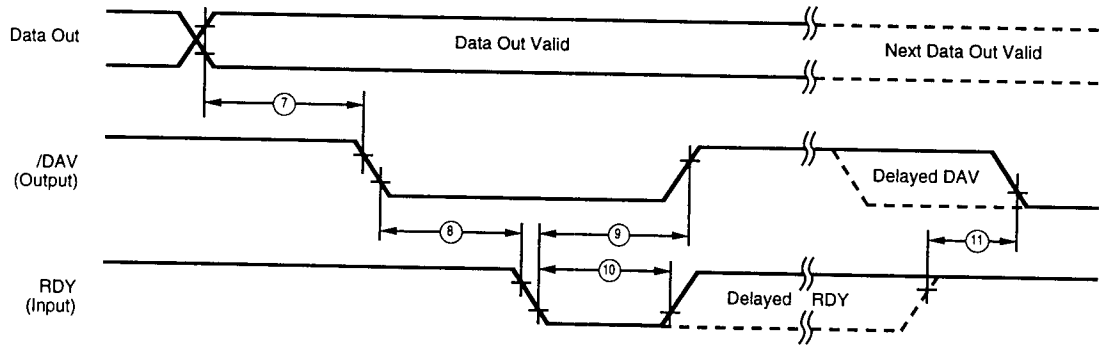

Figure 29. Output Handshake Timing

AC CHARACTERISTICS
Handshake Timing Table

No	Symbol	Parameter	$T_A = 0^\circ\text{C to } +70^\circ\text{C}$		Units	Data Direction
			Min	Max		
1	TsDI(DAV)	Data In Setup Time to /DAV	0		ns	In
2	ThDI(DAV)	RDY to Data In Hold Time	0		ns	In
3	TwDAV	/DAV Width	40		ns	In
4	TdDAVI(RDYf)	/DAV to RDY Delay		70	ns	In
5	TdDAVIr(RDYr)	DAV Rise to RDY Wait Time		40	ns	In
6	TdRDYor(DAVf)	RDY Rise to DAV Delay	0		ns	In
7	TdDO(DAV)	Data Out to DAV Delay		TpC	ns	Out
8	TdDAVO(RDYf)	/DAV to RDY Delay	0		ns	Out
9	TdRDYf(DAVr)	RDY to /DAV Rise Delay		70	ns	Out
10	TwRDY	RDY Width	40		ns	Out
11	TdRDYr(DAVf)	RDY Rise to DAV Wait Time		40	ns	Out

EXPANDED REGISTER FILE CONTROL REGISTERS

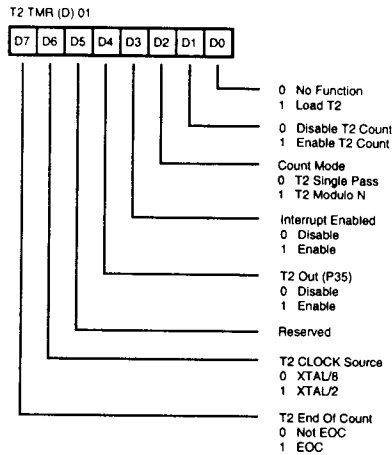

Figure 30. Timer 2 Mode Register (01H: Read/Write)

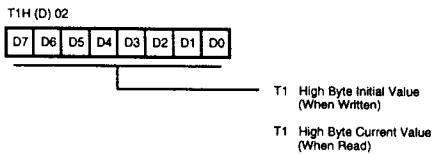

Figure 31. Counter Timer 1 Register High Byte (02H: Read/Write)

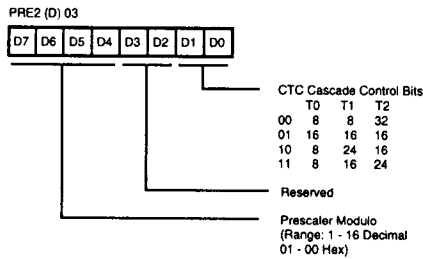

Figure 32. Prescaler 2 Register High Byte (03H: Write Only)

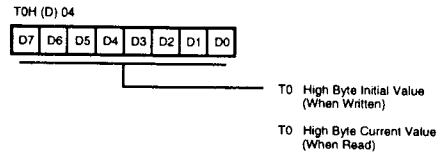

Figure 33. Counter Timer 0 Register High Byte (04H: Read/Write)

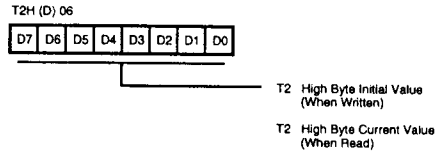

Figure 34. Counter Timer 2 Register High Byte (06H: Read/Write)

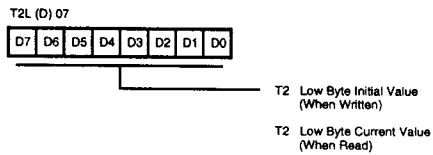

Figure 35. Counter Timer 2 Register Low Byte (07H: Read/Write)

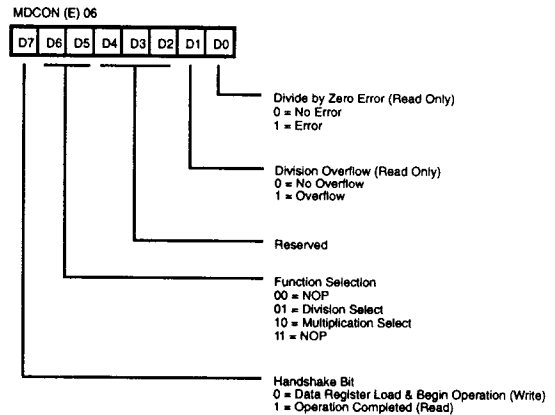

Figure 36. Multiply/Divide Control Register (MDCON)

Z8 CONTROL REGISTERS

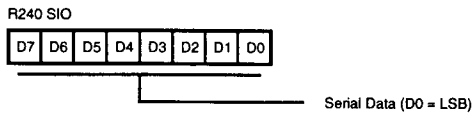

Figure 37. Serial I/O Register (F0H: Read/Write)

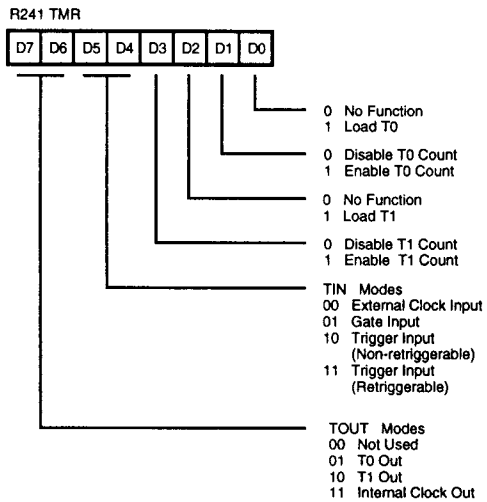

Figure 38. Timer Mode Register (F1H: Read/Write)

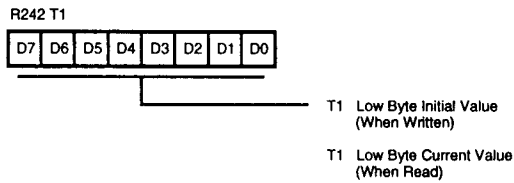

Figure 39. Counter/Timer 1 Register (F2H: Read/Write)

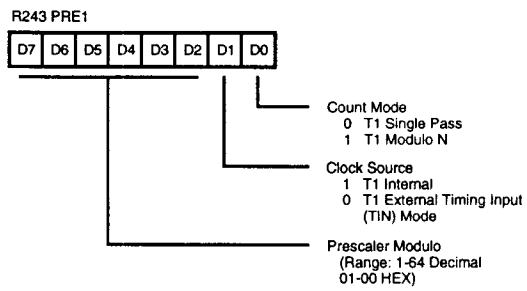

Figure 40. Prescaler 1 Register (F3H: Write Only)

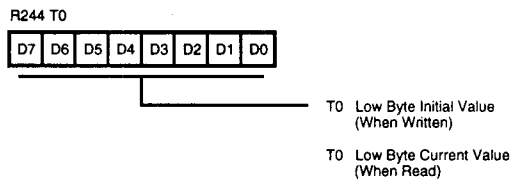

Figure 41. Counter/Timer 0 Register (F4H: Read/Write)

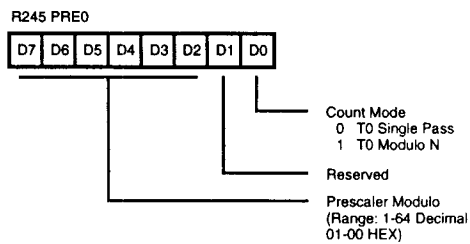

Figure 42. Prescaler 0 Register (F5H: Write Only)

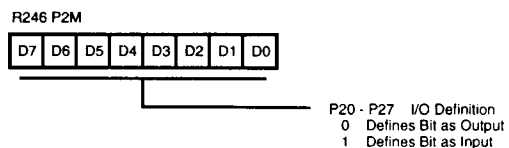

Figure 43. Port 2 Mode Register (F6H: Write Only)

Z8 CONTROL REGISTERS (Continued)

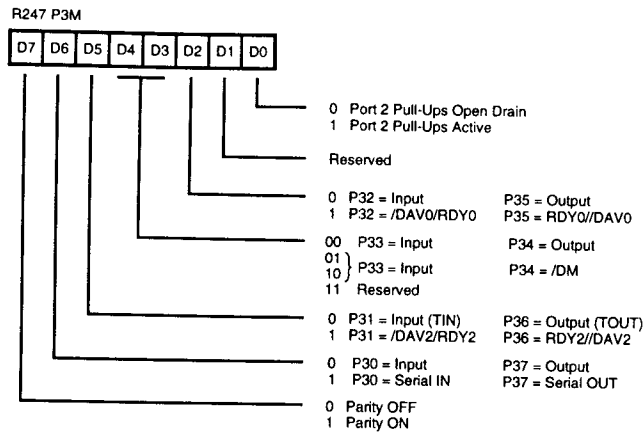

Figure 44. Port 3 Mode Register
(F7H: Write Only)

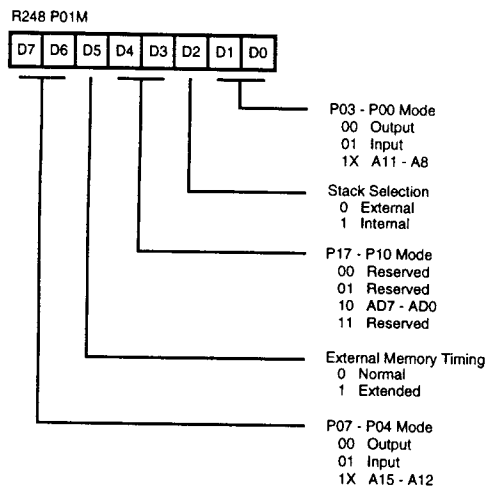

Figure 45. Ports 0 and 1 Mode Registers
(F8H: Write Only)

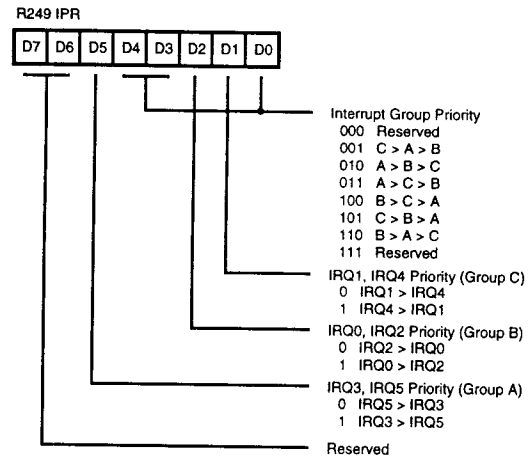

Figure 46. Interrupt Priority Register
(F9H: Write Only)

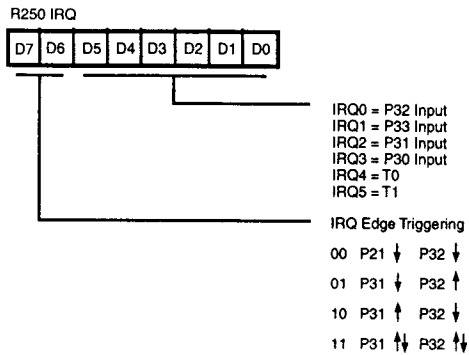

Figure 47. Interrupt Request Register (FAH: Read/Write)

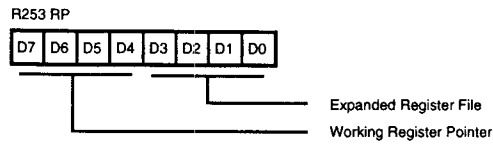

Figure 50. Register Pointer (FDH: Read/Write)

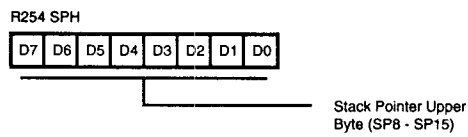

Figure 51. Stack Pointer High (FEH: Read/Write)

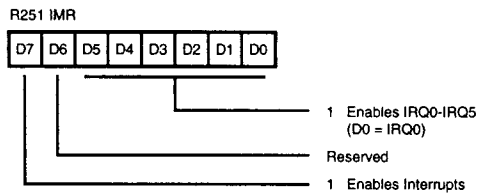

Figure 48. Interrupt Mask Register (FBH: Read/Write)

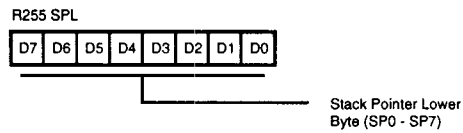

Figure 52. Stack Pointer Low (FFH: Read/Write)

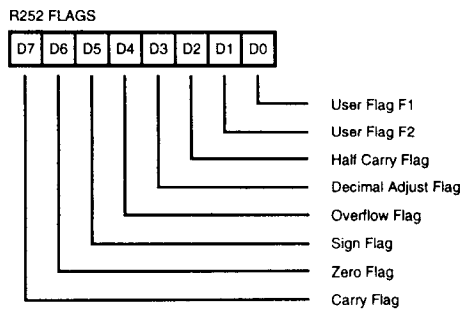

Figure 49. Flag Register (FCH: Read/Write)

INSTRUCTION SET NOTATION

Addressing Modes. The following notation is used to describe the addressing modes and instruction operations as shown in the instruction summary.

Symbol	Meaning
IRR	Indirect register pair or indirect working-register pair address
Irr	Indirect working-register pair only
X	Indexed address
DA	Direct address
RA	Relative address
IM	Immediate
R	Register or working-register address
r	Working-register address only
IR	Indirect-register or indirect working-register address
Ir	Indirect working-register address only
RR	Register pair or working register pair address

Symbols. The following symbols are used in describing the instruction set.

Symbol	Meaning
dst	Destination location or contents
src	Source location or contents
cc	Condition code
@	Indirect address prefix
SP	Stack Pointer
PC	Program Counter
FLAGS	Flag register (Control Register 252)
RP	Register Pointer (R253)
IMR	Interrupt mask register (R251)

Flags. Control register (R252) contains the following six flags:

Symbol	Meaning
C	Carry flag
Z	Zero flag
S	Sign flag
V	Overflow flag
D	Decimal-adjust flag
H	Half-carry flag

Affected flags are indicated by:

0	Clear to zero
1	Set to one
*	Set to clear according to operation
-	Unaffected
x	Undefined

CONDITION CODES

Value	Mnemonic	Meaning	Flags Set
1000		Always True	
0111	C	Carry	C = 1
1111	NC	No Carry	C = 0
0110	Z	Zero	Z = 1
1110	NZ	Not Zero	Z = 0
1101	PL	Plus	S = 0
0101	MI	Minus	S = 1
0100	OV	Overflow	V = 1
1100	NOV	No Overflow	V = 0
0110	EQ	Equal	Z = 1
1110	NE	Not Equal	Z = 0
1001	GE	Greater Than or Equal	(S XOR V) = 0
0001	LT	Less than	(S XOR V) = 1
1010	GT	Greater Than	[Z OR (S XOR V)] = 0
0010	LE	Less Than or Equal	[Z OR (S XOR V)] = 1
1111	UGE	Unsigned Greater Than or Equal	C = 0
0111	ULT	Unsigned Less Than	C = 1
1011	UGT	Unsigned Greater Than	(C = 0 AND Z = 0) = 1
0011	ULE	Unsigned Less Than or Equal	(C OR Z) = 1
0000		Never True	

INSTRUCTION FORMATS

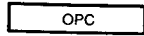

CCF, DI, EI, IRET, NOP,
RCF, RET, SCF



One-Byte Instructions

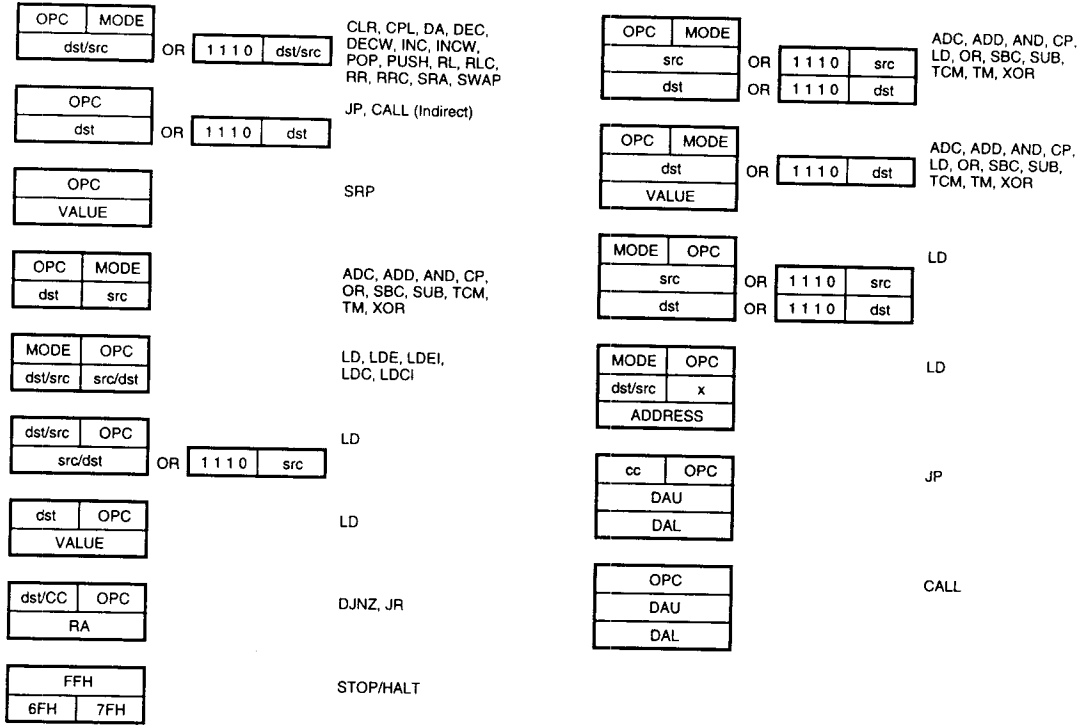

Two-Byte Instructions

Three-Byte Instructions

INSTRUCTION SUMMARY

Note: Assignment of a value is indicated by the symbol " \leftarrow ". For example:

$$dst \leftarrow dst + src$$

indicates that the source data is added to the destination data and the result is stored in the destination location. The

notation "addr (n)" is used to refer to bit (n) of a given operand location. For example:

$$dst(7)$$

refers to bit 7 of the destination operand.

INSTRUCTION SUMMARY (Continued)

Instruction and Operation	Address Mode		Opcode Byte (Hex)	Flags Affected						
	dst	src		C	Z	S	V	D	H	
ADC dst, src dst←dst + src +C	†		1[]	*	*	*	*	0	*	
ADD dst, src dst←dst + src	†		0[]	*	*	*	*	0	*	
AND dst, src dst←dst AND src	†		5[]	-	*	*	0	-	-	
CALL dst SP←SP - 2 @SP←PC, PC←dst	DA IRR		D6 D4	-	-	-	-	-	-	
CCF C←NOT C			EF	*	-	-	-	-	-	
CLR dst dst←0	R IR		B0 B1	-	-	-	-	-	-	
COM dst dst←NOT dst	R IR		60 61	-	*	*	0	-	-	
CP dst, src dst - src	†		A[]	*	*	*	*	-	-	
DA dst dst←DA dst	R IR		40 41	*	*	*	X	-	-	
DEC dst dst←dst - 1	R IR		00 01	-	*	*	*	-	-	
DECW dst dst←dst - 1	RR IR		80 81	-	*	*	*	-	-	
DI IMR(7)←0			8F	-	-	-	-	-	-	
DJNZ r, dst r←r - 1 if r ≠ 0 PC←PC + dst Range: +127, -128	RA		rA r = 0 - F	-	-	-	-	-	-	
EI IMR(7)←1			9F	-	-	-	-	-	-	
HALT			7F	-	-	-	-	-	-	

Instruction and Operation	Address Mode		Opcode Byte (Hex)	Flags Affected						
	dst	src		C	Z	S	V	D	H	
INC dst dst←dst + 1	r R IR		rE r = 0 - F 20 21	-	*	*	*	-	-	
INCW dst dst←dst + 1	RR IR		A0 A1	-	*	*	*	-	-	
IRET FLAGS←@SP; SP←SP + 1 PC←@SP; SP←SP + 2; IMR(7)←1			BF	*	*	*	*	*	*	
JP cc, dst if cc is true PC←dst	DA IRR		cD c = 0 - F 30	-	-	-	-	-	-	
JR cc, dst if cc is true, PC←PC + dst Range: +127, -128	RA		cB c = 0 - F	-	-	-	-	-	-	
LD dst, src dst←src	r r R r r X r lr lr R R R IR IR R	lm R r X r lr r R R R IR IM IM R	rC r8 r9 r = 0 - F C7 D7 E3 F3 E4 E5 E6 E7 F5	-	-	-	-	-	-	
LDC dst, src	r	lrr	C2	-	-	-	-	-	-	
LDCI dst, src dst←src r←r + 1; rr←rr + 1	lr	lrr	C3	-	-	-	-	-	-	

INSTRUCTION SUMMARY (Continued)

Instruction and Operation	Address Mode		Opcode Byte (Hex)	Flags Affected					
	dst	src		C	Z	S	V	D	H
NOP			FF	-	-	-	-	-	-
OR dst, src dst←dst OR src	†		4[]	-	*	*	0	-	-
POP dst dst←@SP; SP←SP + 1	R		50	-	-	-	-	-	-
	IR		51	-	-	-	-	-	-
PUSH src SP←SP - 1; @SP←src		R	70	-	-	-	-	-	-
		IR	71	-	-	-	-	-	-
RCF C←0			CF	0	-	-	-	-	-
RET PC←@SP; SP←SP + 2			AF	-	-	-	-	-	-
RL dst	R		90	*	*	*	*	-	-
	IR		91	*	*	*	*	-	-
RLC dst	R		10	*	*	*	*	-	-
	IR		11	*	*	*	*	-	-
RR dst	R		E0	*	*	*	*	-	-
	IR		E1	*	*	*	*	-	-
RRC dst	R		C0	*	*	*	*	-	-
	IR		C1	*	*	*	*	-	-
SBC dst, src dst←dst←src←C	†		3[]	*	*	*	*	1	*
SCF C←1			DF	1	-	-	-	-	-
SRA dst	R		D0	*	*	*	0	-	-
	IR		D1	*	*	*	0	-	-
SRP src RP←src		Im	31	-	-	-	-	-	-

Instruction and Operation	Address Mode		Opcode Byte (Hex)	Flags Affected					
	dst	src		C	Z	S	V	D	H
STOP			6F	-	-	-	-	-	-

Instruction and Operation	Address Mode		Opcode Byte (Hex)	Flags Affected					
	dst	src		C	Z	S	V	D	H
SUB dst, src dst←dst←src	†		2[]	*	*	*	*	1	*

Instruction and Operation	Address Mode		Opcode Byte (Hex)	Flags Affected					
	dst	src		C	Z	S	V	D	H
SWAP dst	R		F0	X	*	*	X	-	-
	IR		F1	X	*	*	X	-	-

Instruction and Operation	Address Mode		Opcode Byte (Hex)	Flags Affected					
	dst	src		C	Z	S	V	D	H
TCM dst, src (NOT dst) AND src	†		6[]	-	*	*	0	-	-

Instruction and Operation	Address Mode		Opcode Byte (Hex)	Flags Affected					
	dst	src		C	Z	S	V	D	H
TM dst, src dst AND src	†		7[]	-	*	*	0	-	-

Instruction and Operation	Address Mode		Opcode Byte (Hex)	Flags Affected					
	dst	src		C	Z	S	V	D	H
XOR dst, src dst←dst XOR src	†		B[]	-	*	*	0	-	-

† These instructions have an identical set of addressing modes, which are encoded for brevity. The first opcode nibble is found in the instruction set table above. The second nibble is expressed symbolically by a '[]' in this table, and its value is found in the following table to the left of the applicable addressing mode pair.

For example, the opcode of an ADC instruction using the addressing modes r (destination) and Ir (source) is 13.

Address Mode	dst	src	Lower Opcode Nibble
r	r		[2]
r	Ir		[3]
R	R		[4]
R	IR		[5]
R	IM		[6]
IR	IM		[7]

OPCODE MAP

		Lower Nibble (Hex)															
		0	1	2	3	4	5	6	7	8	9	A	B	C	D	E	F
Upper Nibble (Hex)	0	6.5 DEC R1	6.5 DEC IR1	6.5 ADD r1, r2	6.5 ADD r1, lr2	10.5 ADD R2, R1	10.5 ADD IR2, R1	10.5 ADD R1, IM	10.5 ADD IR1, IM	6.5 LD r1, R2	6.5 LD r2, R1	12/10.5 DJNZ r1, RA	12/10.0 JR cc, RA	6.5 LD r1, IM	12.10.0 JP cc, DA	6.5 INC r1	
	1	6.5 RLC R1	6.5 RLC IR1	6.5 ADC r1, r2	6.5 ADC r1, lr2	10.5 ADC R2, R1	10.5 ADC IR2, R1	10.5 ADC R1, IM	10.5 ADC IR1, IM								
	2	6.5 INC R1	6.5 INC IR1	6.5 SUB r1, r2	6.5 SUB r1, lr2	10.5 SUB R2, R1	10.5 SUB IR2, R1	10.5 SUB R1, IM	10.5 SUB IR1, IM								
	3	8.0 JP IRR1	6.1 SRP IM	6.5 SBC r1, r2	6.5 SBC r1, lr2	10.5 SBC R2, R1	10.5 SBC IR2, R1	10.5 SBC R1, IM	10.5 SBC IR1, IM								
	4	8.5 DA R1	8.5 DA IR1	6.5 OR r1, r2	6.5 OR r1, lr2	10.5 OR R2, R1	10.5 OR IR2, R1	10.5 OR R1, IM	10.5 OR IR1, IM								
	5	10.5 POP R1	10.5 POP IR1	6.5 AND r1, r2	6.5 AND r1, lr2	10.5 AND R2, R1	10.5 AND IR2, R1	10.5 AND R1, IM	10.5 AND IR1, IM								
	6	6.5 COM R1	6.5 COM IR1	6.5 TCM r1, r2	6.5 TCM r1, lr2	10.5 TCM R2, R1	10.5 TCM IR2, R1	10.5 TCM R1, IM	10.5 TCM IR1, IM								6.0 STOP
	7	10/12.1 PUSH R2	12/14.1 PUSH IR2	6.5 TM r1, r2	6.5 TM r1, lr2	10.5 TM R2, R1	10.5 TM IR2, R1	10.5 TM R1, IM	10.5 TM IR1, IM								7.0 HALT
	8	10.5 DECW RR1	10.5 DECW IR1	12.0 LDE r1, lr2	18.0 LDEI lr1, lr2												6.1 DI
	9	6.5 RL R1	6.5 RL IR1	12.0 LDE r2, lrr1	18.0 LDEI lr2, lrr1												6.1 EI
	A	10.5 INCW RR1	10.5 INCW IR1	6.5 CP r1, r2	6.5 CP r1, lr2	10.5 CP R2, R1	10.5 CP IR2, R1	10.5 CP R1, IM	10.5 CP IR1, IM								14.0 RET
	B	6.5 CLR R1	6.5 CLR IR1	6.5 XOR r1, r2	6.5 XOR r1, lr2	10.5 XOR R2, R1	10.5 XOR IR2, R1	10.5 XOR R1, IM	10.5 XOR IR1, IM								16.0 IRET
	C	6.5 RRC R1	6.5 RRC IR1	12.0 LDC r1, lr2	18.0 LDCI lr1, lr2				10.5 LD r1, x, R2								6.5 RCF
	D	6.5 SRA R1	6.5 SRA IR1	12.0 LDC r2, lrr1	18.0 LDCI lr2, lrr1	20.0 CALL* IRR1		20.0 CALL DA	10.5 LD r2, x, R1								6.5 SCF
	E	6.5 RR R1	6.5 RR IR1		6.5 LD r1, IR2	10.5 LD R2, R1	10.5 LD IR2, R1	10.5 LD R1, IM	10.5 LD IR1, IM								6.5 CCF
	F	8.5 SWAP R1	8.5 SWAP IR1		6.5 LD lr1, r2		10.5 LD R2, IR1										6.0 NOP

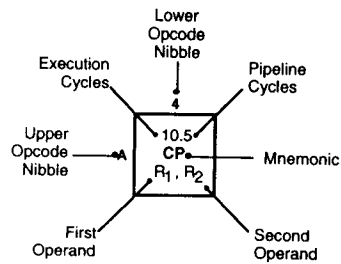

Legend:
 R = 8-bit address
 r = 4-bit address
 R₁ or r₂ = Dst address
 R₁ or r₂ = Src address

Sequence:
 Opcode, First Operand,
 Second Operand

Note: The blank areas are not defined.

* 2-byte instruction appears
 as a 3-byte instruction

PACKAGE INFORMATION

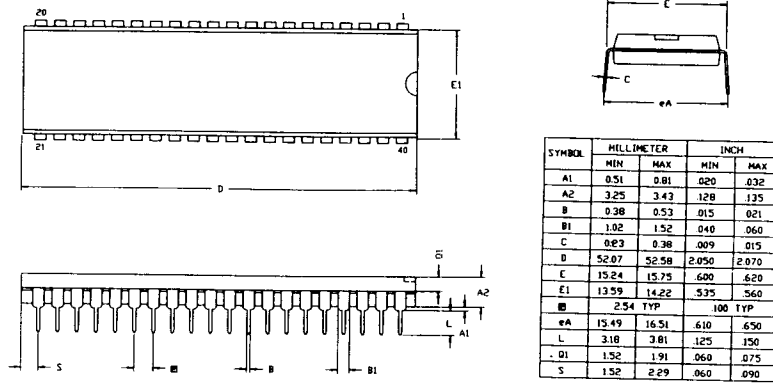

CONTROLLING DIMENSIONS : INCH

40-Pin DIP Package Diagram

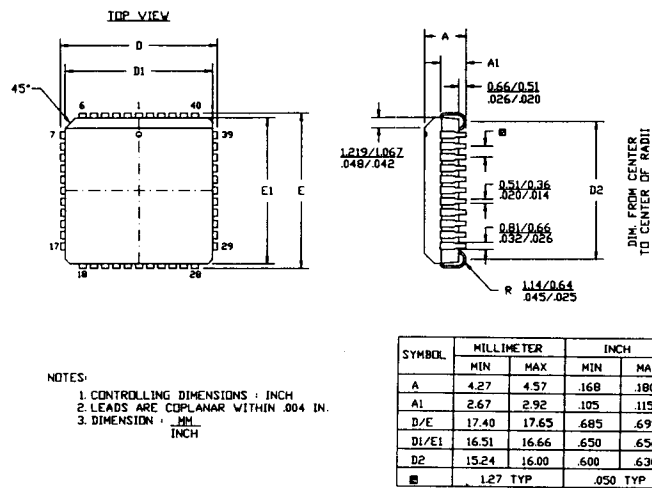

- NOTES:
 1. CONTROLLING DIMENSIONS : INCH
 2. LEADS ARE COPLANAR WITHIN .004 IN.
 3. DIMENSION : $\frac{MM}{INCH}$

44-Pin PLCC Package Diagram

PACKAGE INFORMATION (Continued)

NOTES:
 1. CONTROLLING DIMENSIONS : MILLIMETER
 2. LEAD COPLANARITY : MAX .10mm
 .004"

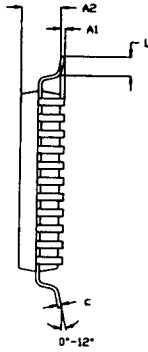
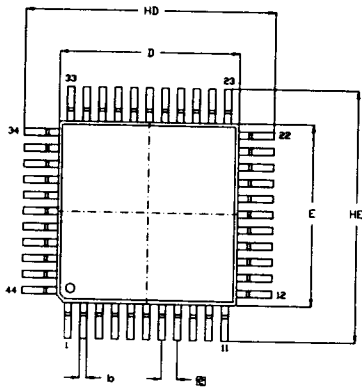

SYMBOL	MILLIMETER		INCH	
	MIN	MAX	MIN	MAX
A1	0.05	0.25	.002	.010
A2	2.05	2.25	.081	.089
b	0.25	0.45	.010	.018
c	0.13	0.20	.005	.008
HD	13.70	14.30	.539	.563
D	9.90	10.10	.390	.398
HE	13.70	14.30	.539	.563
E	9.90	10.10	.390	.398
□	0.80 TYP		.031 TYP	
L	0.60	1.20	.024	.047

44-Pin QFP Package Diagram

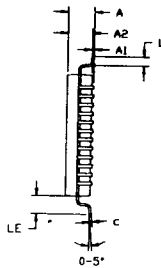
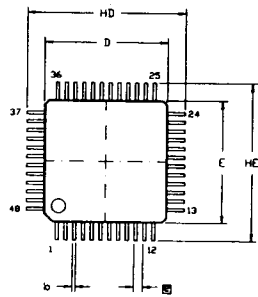

SYMBOL	MILLIMETER		INCH	
	MIN	MAX	MIN	MAX
A	1.35	1.60	.053	.063
A1	0.05	0.20	.002	.008
A2	1.30	1.50	.051	.059
b	0.15	0.26	.006	.010
c	0.10	0.18	.004	.007
HD	8.60	9.40	.339	.370
D	6.90	7.10	.272	.280
HE	8.60	9.40	.339	.370
E	6.90	7.10	.272	.280
□	0.50 TYP		.020 TYP	
L	0.30	0.70	.012	.028
LE	0.90	1.10	.035	.043

1. CONTROLLING DIMENSIONS : MM
 2. MAX COPLANARITY : .10mm
 .004"

48-Pin VQFP Package Diagram

ORDERING INFORMATION

Z86C93

20 MHz

44-pin PLCC
Z86C9320VSC

44-pin QFP
Z86C9320FSC

40-pin DIP
Z86C9320PSC

48-pin VQFP
Z80C9320ASC

25 MHz

44-pin PLCC
Z86C9325VSC

44-pin QFP
Z86C9325FSC

40-pin DIP
Z86C9325PSC

48-pin VQFP
Z80C9325ASC

33 MHz

44-pin PLCC
Z86C9333VSC

44-pin QFP
Z86C9333FSC

40-pin DIP
Z86C9333PSC

48-pin VQFP
Z80C9333ASC

For fast results, contact your local Zilog sales office for assistance in ordering the part desired.

Package

V = Plastic Leaded Chip Carrier
P = Plastic Dual In Line Package

Longer Lead Time

F = Plastic Quad Flat Pack
A = Very Small Quad Flat Pack

Temperature

S = 0°C to +70°C

Speed

20 = 20 MHz
25 = 25 MHz
33 = 33 MHz

Environmental

C = Standard Flow

Example:

Z 86C93 33 V S C is an 86C93 33 MHz, PLCC, 0°C to +70°C, Plastic Standard Flow

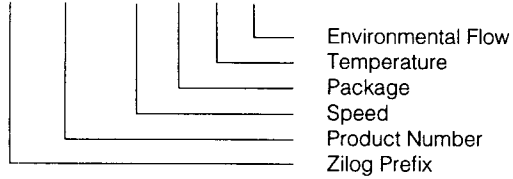

Notes:

**ZILOG DOMESTIC SALES OFFICES
AND TECHNICAL CENTERS****CALIFORNIA**

Agoura 818-707-2160
Campbell 408-370-8120
Irvine 714-453-9701

COLORADO

Boulder 303-494-2905

FLORIDA

Largo 813-585-2533

GEORGIA

Norcross 404-448-9370

ILLINOIS

Schaumburg 708-517-8080

MINNESOTA

Minneapolis 612-944-0737

NEW HAMPSHIRE

Nashua 603-888-8590

OHIO

Independence 216-447-1480

OREGON

Portland 503-274-6250

PENNSYLVANIA

Ambler 215-653-0230

TEXAS

Dallas 214-987-9987

WASHINGTON

Seattle 206-523-3591

INTERNATIONAL SALES OFFICES**CANADA**

Toronto 416-673-0634

GERMANY

Munich 49-8967-2045
Sömmerda 49-3634-23906

JAPAN

Tokyo 81-3-3587-0528

HONG KONG

Kowloon 852-7238979

KOREA

Seoul 82-2-577-3272

SINGAPORE

Singapore 65-2357155

TAIWAN

Taipei 886-2-741-3125

UNITED KINGDOM

Maidenhead 44-628-392-00

© 1992 by Zilog, Inc. All rights reserved. No part of this document may be copied or reproduced in any form or by any means without the prior written consent of Zilog, Inc. The information in this document is subject to change without notice. Devices sold by Zilog, Inc. are covered by warranty and patent indemnification provisions appearing in Zilog, Inc. Terms and Conditions of Sale only. Zilog, Inc. makes no warranty, express, statutory, implied or by description, regarding the information set forth herein or regarding the freedom of the described devices from intellectual property infringement. Zilog, Inc. makes no warranty of mer-

chantability or fitness for any purpose. Zilog, Inc. shall not be responsible for any errors that may appear in this document. Zilog, Inc. makes no commitment to update or keep current the information contained in this document.

Zilog, Inc. 210 East Hacienda Ave.
Campbell, CA 95008-6600
Telephone (408) 370-8000
Telex 910-338-7621
FAX 408 370-8056

Mouser Electronics

Authorized Distributor

Click to View Pricing, Inventory, Delivery & Lifecycle Information:

ZiLOG:

[Z86C9325ASC](#) [Z86C9325VSC](#) [Z86C9320PSG](#) [Z86C9320VSG](#) [Z86C9325VSG](#) [Z86C9333VSG](#) [Z86C9325PSG](#)
[Z86C9320ASG](#) [Z86C9325ASG](#) [Z86C9333ASG](#) [Z86C9320VSC](#) [Z86C9325PSC](#) [Z86C9333VSC](#) [Z86C9320FSG](#)
[Z86C9320PSC](#) [Z86C9325FSG](#) [Z86C9333FSG](#) [Z86C9325FSC](#)